

THIS DOCUMENT IS THE PROPERTY OF KEYSTONE ELECTRONICS CORP. AND SHALL NOT BE REPRODUCED, DISTRIBUTED OR USED AS A BASIS FOR MANUFACTURE WITHOUT PRIOR WRITTEN PERMISSION FROM KEYSTONE ELECTRONICS CORP.

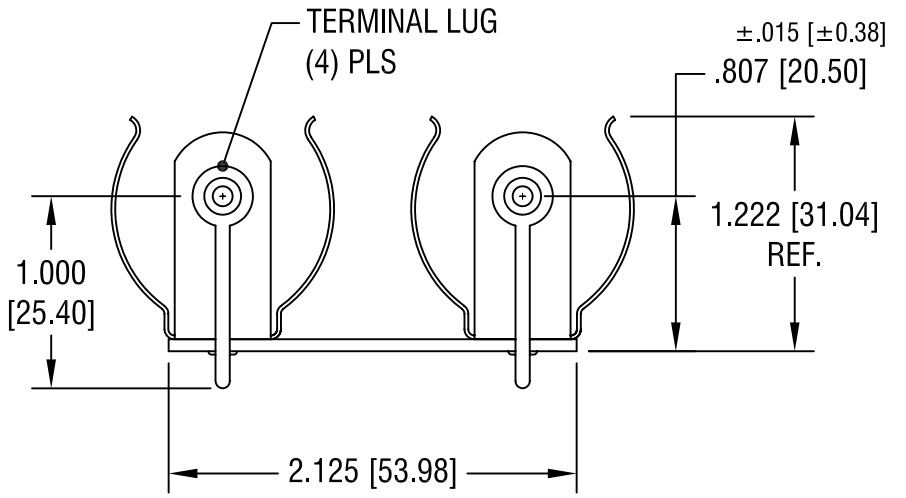
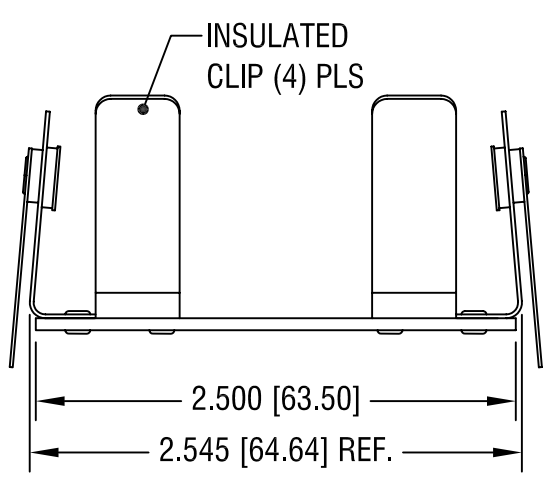
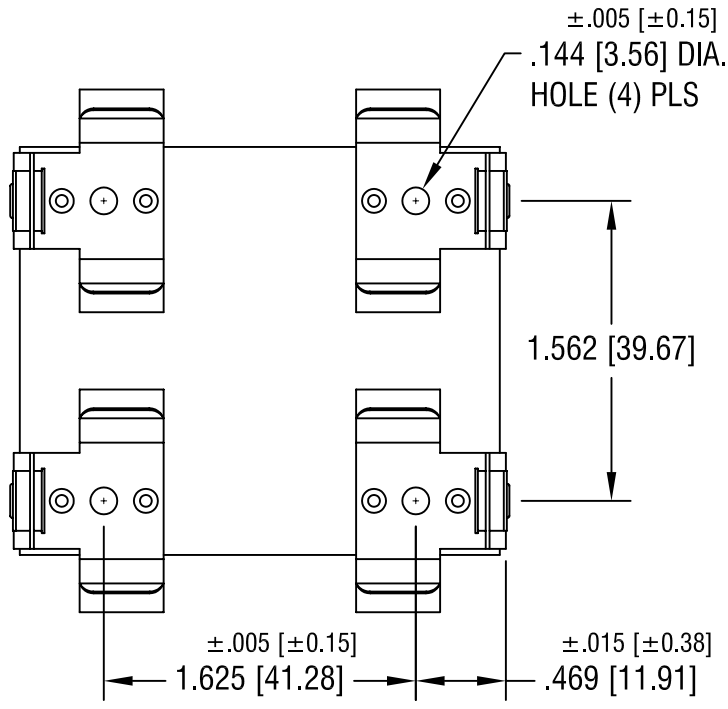
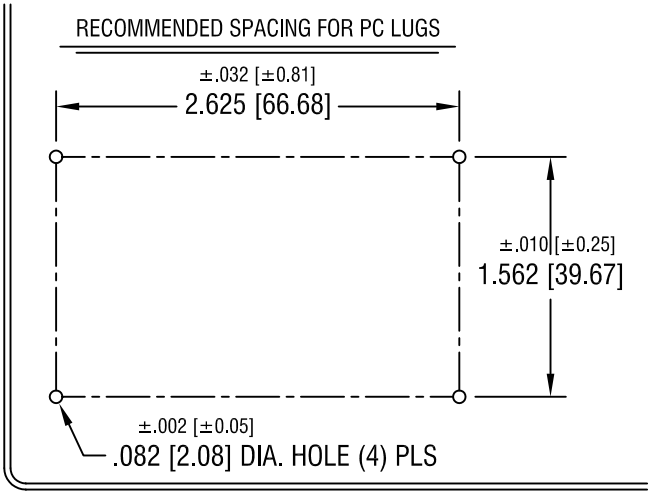

NOTES:

- 1. BASE: MAT'L - .062 [1.57] TH'K PHENOLIC
- CLIP: MAT'L - SPRING STEEL
- FINISH - NICKEL PLATE
- LUG: MAT'L - BRASS
- FINISH - TIN PLATE

KEYSTONE ELECTRONICS CORP.			
ASTORIA, N.Y. 11105-2017			
PART NAME			
INSULATED BATTERY HOLDER (2) 'D'			
MATERIAL			
AS NOTED			
FINISH		DRN BY	DATE
AS NOTED		BOONE	8.19.82
		APP'D	SCALE
		LN	1X
TOLERANCES		DWG NO.	
INCH	[MM]	2233	
DECIMAL	± .010 [± 0.25]		
ANGULAR	± 1°		
UNLESS OTHERWISE SPECIFIED		CODE	
		C	

6.15.04	CHANGE AS PER ECN 04-048	A
DATE	DESCRIPTION	REV.