

U12 4 POLE MALE

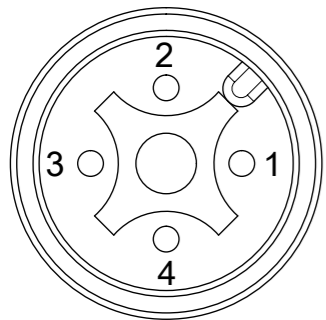

VIEW FROM THE FRONT SIDE

Pin	Wire color	
1	BROWN	BN
2	WHITE	WH
3	BLUE	BU
4	BLACK	BK

U12 5 POLE MALE

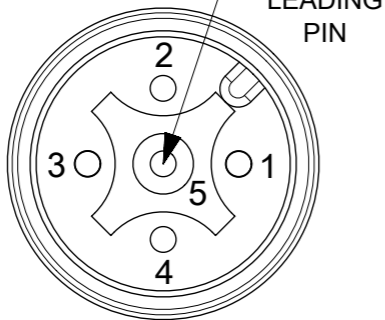

VIEW FROM THE FRONT SIDE

Pin	Wire color	
1	BROWN	BN
2	WHITE	WH
3	BLUE	BU
4	BLACK	BK
5	GREEN/YELLOW	GN/YE

U12 8 POLE MALE

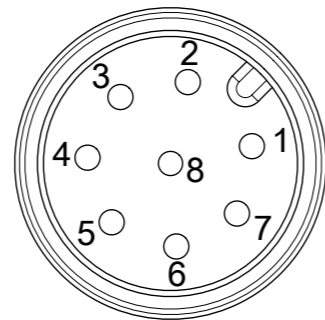

VIEW FROM THE FRONT SIDE

Pin	Wire color	
1	WHITE	WH
2	BROWN	BN
3	GREEN	GN
4	YELLOW	YE
5	GREY	GY
6	PINK	PK
7	BLUE	BU
8	RED	RD

U12 12 POLE MALE

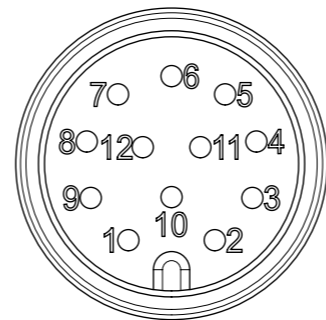

VIEW FROM THE FRONT SIDE

Pin	Wire color	
1	WHITE	WH
2	BROWN	BN
3	GREEN	GN
4	YELLOW	YE
5	GREY	GY
6	PINK	PK
7	BLUE	BU
8	RED	RD
9	BLACK	BK
10	VIOLET	VT
11	GREY/PINK	GY/PK
12	RED/BLUE	RD/BU

PANEL CUTOUT

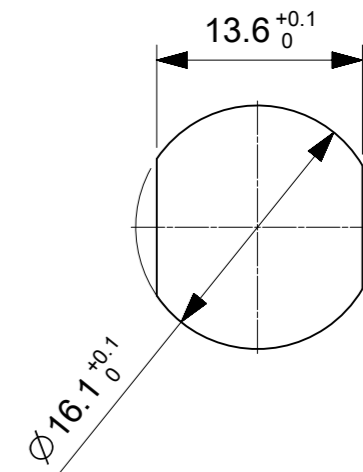

NOTES:

- VOLTAGE RATING 4P: 250V AC / DC
- VOLTAGE RATING 5P: 60V AC / DC
- VOLTAGE RATING 8P: 30V AC / 36V DC
- VOLTAGE RATING 12P: 30V AC / DC
- AMPERAGE RATING 4P, 5P: 4A
- AMPERAGE RATING 8P: 2A
- AMPERAGE RATING 12P: 1.5A
- PROTECTION CLASS: IP 67
- OPERATING TEMPERATURE: -25°C to +90°C

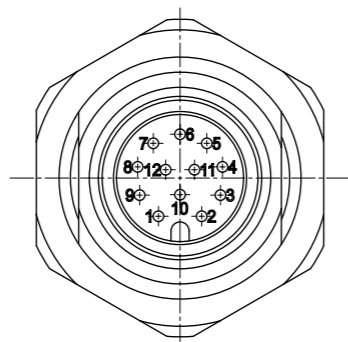

KEYWAY POSITION FOR 12P

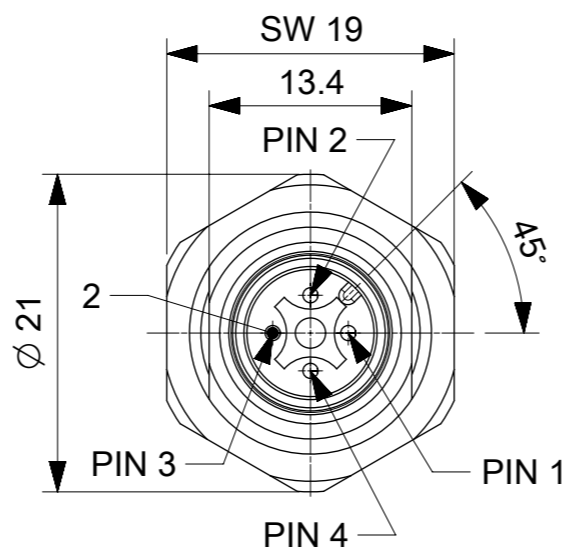

KEYWAY POSITION FOR 4P, 5P AND 8P

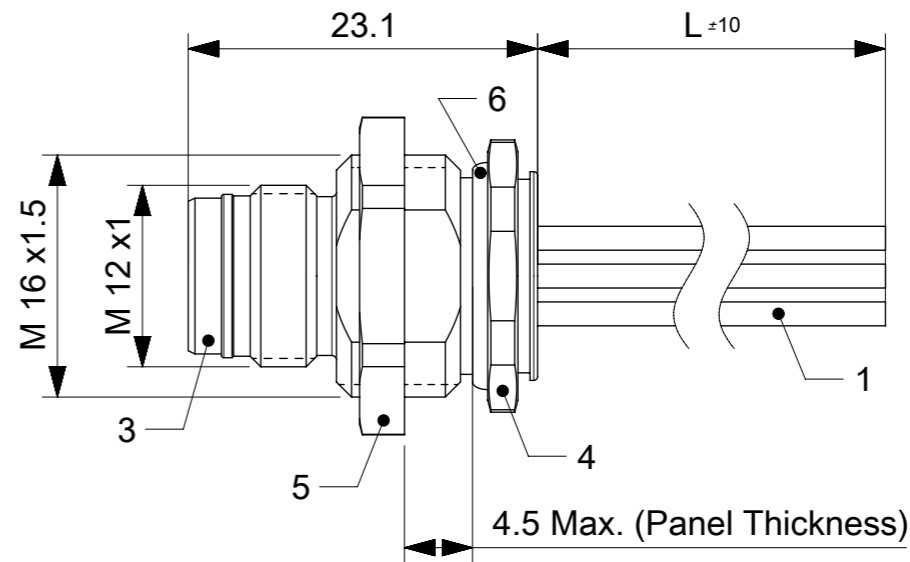

TABLE 1

ITEM	QTY.	DESCRIPTION	MATERIAL	FINISH
7	-	POTTING MATERIAL	WEVO	-
6	1	O-RING BLACK	NBR	-
5	1	LOCKNUT M16x1.5	BRASS	Ni
4	1	SHELL M12x1 M16x1.5	BRASS	Ni
3	1	INSERT U12 MALE 4P/5P/8P/12P BK	PA	-
2	4/5/8/12	CONTACT MALE	BRASS	Au
1	-	WIRE 22/24/26 AWG UL1569	PVC	-

RELEASE STATUS P1 RELEASE DATE 30.05.2017 12:22:41

<p>QUALITY SYMBOLS</p> <ul style="list-style-type: none"> FA = 0 FE = 0 FP = 0 FV = 0 FC = 0 FX = 0 FS = 0 FT = 0 				<p>THIS DRAWING CONTAINS INFORMATION THAT IS PROPRIETARY TO MOLEX ELECTRONIC TECHNOLOGIES, LLC AND SHOULD NOT BE USED WITHOUT WRITTEN PERMISSION</p>			
<p>EC NO: 117406</p> <p>DRWN: FGAIK</p> <p>CHK'D: BBRAUCH</p> <p>APP: 2017/05/30</p>		<p>GENERAL TOLERANCES (UNLESS SPECIFIED)</p> <p>ANGULAR TOL ± 1.0 °</p> <p>4 PLACES ±</p> <p>3 PLACES ±</p> <p>2 PLACES ± 0.05</p> <p>1 PLACE ± 0.3</p> <p>0 PLACES ± 0.5</p>		<p>DIMENSION UNITS: MM</p> <p>SCALE: 2:1</p> <p>DRWN BY: FGAIK</p> <p>DATE: 2016/11/17</p> <p>CHK'D BY:</p> <p>DATE:</p> <p>APPR BY: RSILLER</p> <p>DATE: 2016/11/23</p>		<p>molex</p> <p>REC U12 XP AC MA PVC XM M16 BM BRA</p>	
<p>DRAFT WHERE APPLICABLE MUST REMAIN WITHIN DIMENSIONS</p>		<p>DRAWING SIZE: A3</p> <p>THIRD ANGLE PROJECTION</p>		<p>PRODUCT CUSTOMER DRAWING</p>			
<p>EC NO: 117406</p> <p>DRWN: FGAIK</p> <p>CHK'D: BBRAUCH</p> <p>APP: 2017/05/30</p>		<p>DRAWING SIZE: A3</p> <p>THIRD ANGLE PROJECTION</p>		<p>SERIES: 120084</p> <p>MATERIAL NUMBER: SEE SHEET 2</p> <p>CUSTOMER: GENERAL MARKET</p>			
<p>REV: A1</p>		<p>DRAWING SIZE: A3</p> <p>THIRD ANGLE PROJECTION</p>		<p>DOCUMENT NUMBER: 1200845036</p> <p>DOC TYPE: PSD</p> <p>DOC PART: 000</p> <p>SHEET NUMBER: 1 OF 2</p>			

ENGINEERING No. - NUMERICAL CODE (Available parts see PART LIST table. Other parts available upon request)

W R X U 4 6 X X X X X X X X

OPTIONS

WR = U12 REC

Poles:
4 = 4 Poles
5 = 5 Poles
8 = 8 Poles
C = 12 Poles

Shell Type

Wires:
E01 = 26AWG PVC
E02 = 24AWG PVC
E03 = 22AWG PVC

Unit:
M = Meter
C = Centimeter

Length
Examples:
005 = 0.5 unit
010 = 1 unit
100 = 10 units

Shell Material
blank, 3 = Brass

WIRES INFORMATION

WIRE TYPE	AWG	CONSTRUCTION	INSULATION	UL	RATED TEMPERATURE	RATED VOLTAGE	INSULATION DIAMETER
E01	26	7x0.16mm	PVC	UL 1569	105°C	300V	1.30±0.05mm
E02	24	11x0.16mm	PVC	UL 1569	105°C	300V	1.43±0.05mm
E03	22	17x0.16mm	PVC	UL 1569	105°C	300V	1.58±0.05mm

PART LIST

Molex PN	Engineering No.	L [mm]
1200845019	WRCU46E01C300	300
1200845036	WR4U46E03C3003	300
1200845098	WR8U46E02C300	300
1200845161	WR5U46E03C3003	300
1200848122	WRCU46E01M010	1000
1200848171	WR8U46E02C500	500
1200848179	WR4U46E03C0503	50

RELEASE STATUS P1 RELEASE DATE 30.05.2017 12:22:41

QUALITY SYMBOLS	THIS DRAWING CONTAINS INFORMATION THAT IS PROPRIETARY TO MOLEX ELECTRONIC TECHNOLOGIES, LLC AND SHOULD NOT BE USED WITHOUT WRITTEN PERMISSION				
	2017/05/25	2017/05/30	GENERAL TOLERANCES (UNLESS SPECIFIED)	DIMENSION UNITS SCALE	
FA = 0	EC NO: 117406 DRWN: FGAIK CHK'D: BBRAUCH REV APPR:	2017/05/30	ANGULAR TOL ± 1.0 °	MM 1:1	
FE = 0			4 PLACES ±	DRWN BY DATE	
FF = 0			3 PLACES ±	FGAIK 2016/11/17	
FV = 0			2 PLACES ± 0.05	CHK'D BY DATE	
FC = 0			1 PLACE ± 0.3	APPR BY DATE	
FX = 0			0 PLACES ± 0.5	RSILLER 2016/11/23	
FY = 0	DRAFT WHERE APPLICABLE MUST REMAIN WITHIN DIMENSIONS		DRAWING SIZE THIRD ANGLE PROJECTION		
	A1		A3		
RELEASE STATUS P1		RELEASE DATE 30.05.2017	12:22:41	 REC U12 XP AC MA PVC XM M16 BM BRA PRODUCT CUSTOMER DRAWING SERIES 120084 MATERIAL NUMBER SEE PART LIST CUSTOMER GENERAL MARKET DOCUMENT NUMBER 1200845036 DOC TYPE PSD DOC PART 000 SHEET NUMBER 2 OF 2	