

Jul.1.2019 Copyright 2019 HIROSE ELECTRIC CO., LTD. All Rights Reserved.
 In case of consideration for using Automotive equipment / device which demand high reliability, kindly contact our sales window correspondents.

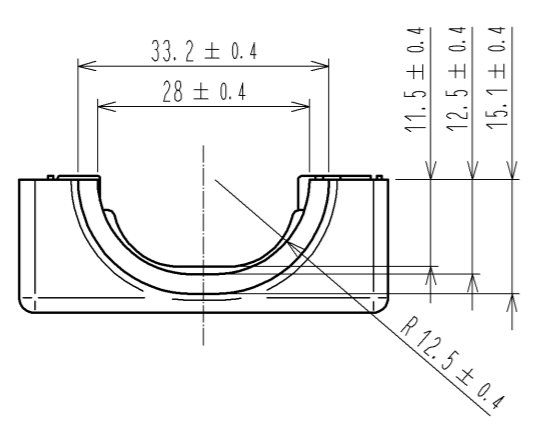

2 ATTACHMENT

JIS B 1188 : CROSS RECESSED NEED SCREWS WITH CAPTIVE WASHER
 M4×0.7×16

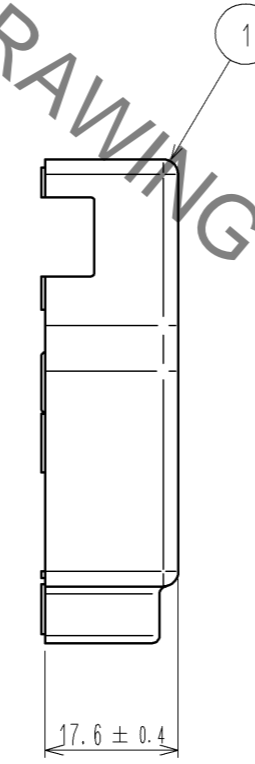
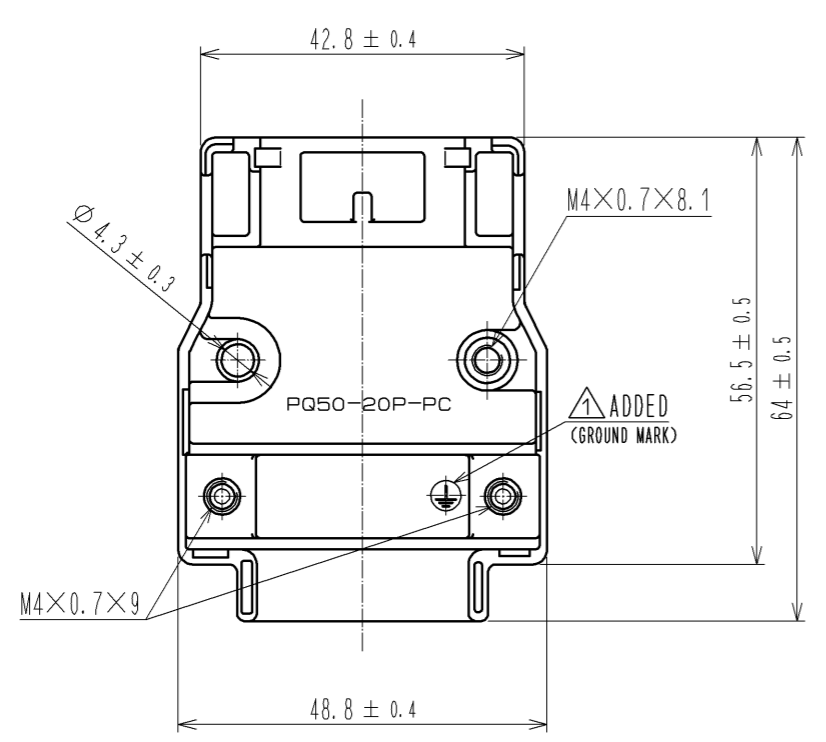
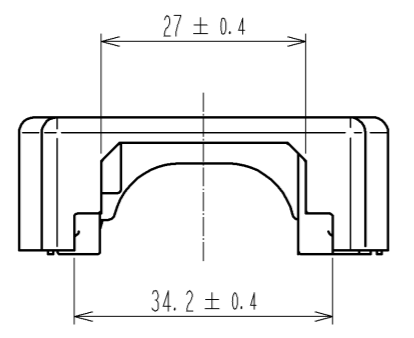
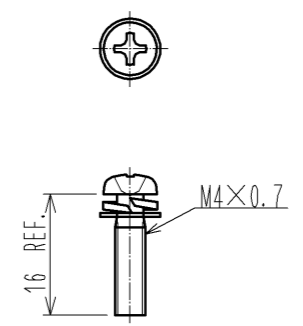

3 ELECTRODE TOUCHED AREA FOR RACK PLATING

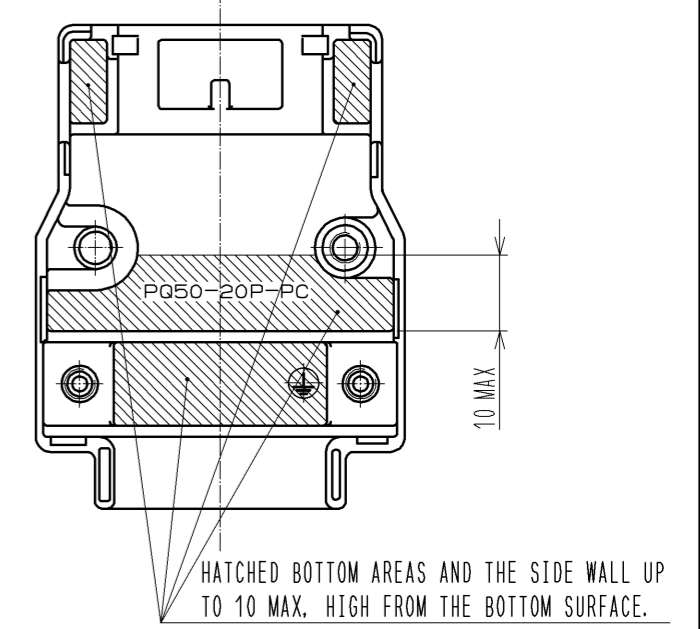
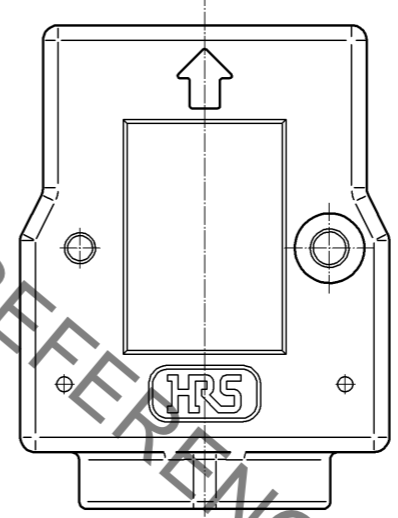

- NOTE 1. REFER TO ETAD-E 2925 FOR THE APPLICABLE COMPONENTS ASSEMBLED WITH THIS PRODUCT.
 2. SWELLING MAX 1.2mm DIA. AND 0.15mm HEIGHT COULD APPEAR ON THE SURFACE DUE TO DIE-CASTING, BUT IT DOESN'T AFFECT THE PERFORMANCE.
 3 THE COLOR OF HATCHED AREA COULD BE DIFFERENT DUE TO THE RACK PLATING PROCESS, TOUCHING THE ELECTRODES TO THE SPECIFIED AREA, BUT IT DOESN'T AFFECT THE PERFORMANCE.
 4. THIS PRODUCT IS AVAILABLE BY 100 pcs./box UNIT.

1	ZDC2	SURFACE PLATING : NICKEL UNDER PLATING : COPPER	2	STEEL	SURFACE PLATING : NICKEL UNDER PLATING : COPPER		
NO.	MATERIAL	FINISH . REMARKS	NO.	MATERIAL	FINISH . REMARKS		
UNITS mm		SCALE 1 : 1	COUNT 1	DESCRIPTION OF REVISIONS DIS-E-004870	DESIGNED TY. MIURA	CHECKED AH. KODAMA	DATE 13. 12. 09
HRS HIROSE ELECTRIC CO., LTD.		APPROVED : KN. ICHIKAWA 10. 09. 29	DRAWING NO. EDC3-126914-00				
		CHECKED : KN. ICHIKAWA 10. 09. 29	PART NO. PQ50-20P-PC				
		DESIGNED : TY. MIURA 10. 09. 29	CODE NO. CL236-2000-8-00				
		DRAWN : TF. HIGASHIYAMA 10. 09. 25					

HRS DRAWING FOR REFERENCE