

NOM02A4-MW60G

200DPI Ultra High-Speed Contact Image Sensor Module

Description

The NOM02A4-MW60G contact image sensor (CIS) module integrates a white LED light source, lens and image sensor in a compact housing. The module is designed for document scanning, mark reading, gaming and office automation equipment applications and is suitable for scanning documents up to 216 mm wide. Four parallel analog video outputs are used to achieve an ultra high-speed scanning rate of 90 μ s/line. The NOM02A4-MW60G module employs proprietary CMOS image sensing technology from ON Semiconductor to achieve high-speed performance and high sensitivity.

Features

- Light Source, Lens and Sensor are Integrated Into a Single Module
- 216 mm Scanning Width at 7.9 dots per mm Resolution
- 90 μ sec/Line Scanning Speed @ 5.0 MHz Pixel Rate
- Four Parallel Analog Video Outputs
- Supports A4 Paper Size at up to 286 Pages per Minute
- White LED Light Source
- Wide Dynamic Range
- Compact 232.1 mm x 19.2 mm x 13.7 mm Module Housing
- Low Power
- Light Weight 2.5 oz Packaging
- These Devices are Pb-Free, Halogen Free/BFR Free and are RoHS Compliant

Applications

- Currency Verification
- Document Scanning
- Mark Readers Including Balloting, Test Scoring and Gaming Machines
- Office Automation Equipment

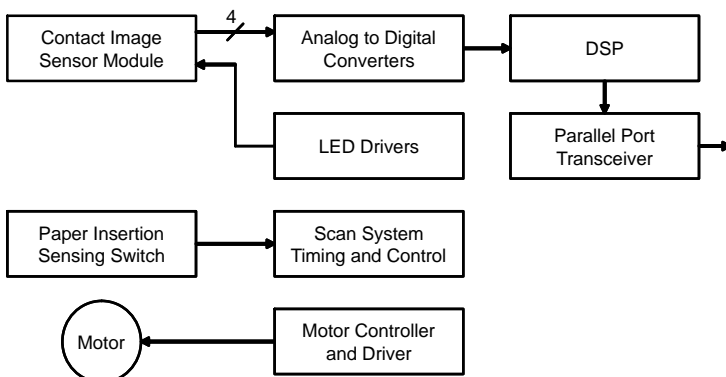

Figure 1. Typical Scanner Application



ON Semiconductor®

www.onsemi.com



IMAGE SENSOR MODULE A4
CASE MODAB

MARKING DIAGRAM

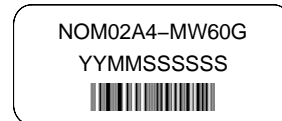

YY = Year
MM = Month
SSSSSS = Serial Number
G = Pb-Free Package

CONNECTOR PIN ASSIGNMENT

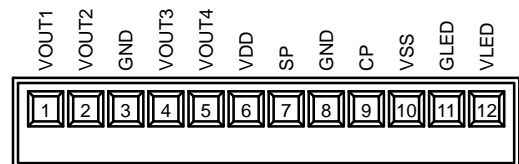

ORDERING INFORMATION

See detailed ordering and shipping information in the package dimensions section on page 2 of this data sheet.

NOM02A4-MW60G

Table 1. ORDERING INFORMATION

Part Number	Package	Shipping Configuration
NOM02A4-MW60G	(Pb-free)	100 per packing carton

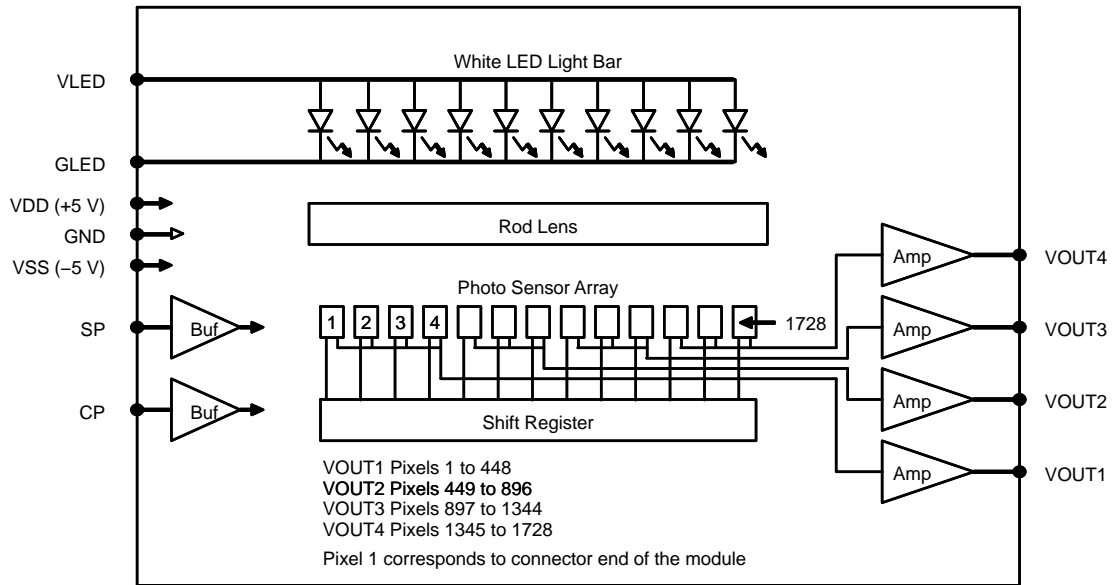

Figure 2. Simplified Block Diagram

Table 2. PIN FUNCTION DESCRIPTION

Pin	Pin Name	Description
1	VOUT1	Analog Video Output 1
2	VOUT2	Analog Video Output 2
3	GND	Ground
4	VOUT3	Analog Video Output 3
5	VOUT4	Analog Video Output 4
6	VDD	+5 V power supply
7	SP	Shift register start pulse
8	GND	Ground
9	CP	Sampling clock pulse
10	VSS	-5 V to -12 V power supply
11	GLED	Ground for the LED light source
12	VLED	Power supply for the LED light source

NOM02A4–MW60G

Table 3. ABSOLUTE MAXIMUM RATINGS

Parameter	Symbol	Value	Unit
Power supply voltage	V_{DD}	7	V
	V_{SS}	-15	V
	V_{LED}	6	V
Power supply current	I_{LED}	550	mA
Input voltage range for SP, CP	V_{in}	-0.5 to $V_{DD} + 0.5$	V
Storage Temperature	T_{STG}	-20 to 75	°C
Storage Humidity, Non-Condensing	H_{STG}	10 to 90	%
ESD Capability, Contact Discharge (Note 1)	ESD_{HBM}	± 2	kV

Stresses exceeding those listed in the Maximum Ratings table may damage the device. If any of these limits are exceeded, device functionality should not be assumed, damage may occur and reliability may be affected.

1. This module assembly has been ESD tested to IEC61000-4-2 (HBM) Contact Discharge

Table 4. RECOMMENDED OPERATING RANGES (Unless otherwise specified, these specifications apply $T_A = 25^\circ\text{C}$) (Note 2)

Parameter	Symbol	Min	Typ	Max	Unit
Power supply voltage (Note 3)	V_{DD}	4.5	5	5.5	V
	V_{SS}	-12	-5	-4.5	V
	V_{LED}	4.5	5	5.5	V
Power supply current	I_{DD}	50	87	95	mA
	I_{SS}	20	25	30	mA
	I_{LED}	270	350	430	mA
Low level input voltage for SP, CP	V_{IL}	0	0	0.8	V
High level input voltage for SP, CP	V_{IH}	4.5	5.0	$V_{DD} + 0.3$	V
Line scanning rate (Note 4)	T_{int}	75	90	224	μs
Clock frequency (Note 5)	f	2.0	5.0	6.0	MHz
Clock period	t_o	166	200	500	ns
Clock pulse width (Note 6)	t_w	42	50	125	ns
Clock pulse high duty cycle	DC_{CP}	20	25	60	%
Start pulse width (Note 6)	t_{wSP}	150	180	480	ns
Start pulse setup time	t_{su}	20			ns
Start pulse hold time	t_h	20			ns
Prohibit crossing time (Note 7)	t_{prh}	20			ns
Clock to Video output propagation delay rising (Note 8)	t_{pcor}	100			ns
Clock to Video output propagation delay falling (Note 8)	t_{pcof}	20			ns
Operating Temperature	T_{op}	0		50	°C
Operating Humidity, Non-Condensing	H_{op}	10		60	%

2. Refer to Figure 3 for more information on AC characteristics
3. V_{LED} directly affects illumination intensity, which directly affects V_{OUT} .
4. T_{int} is the line scanning rate or integration time. T_{int} is determined by the interval between two start pulses. The clock is proportional to T_{int} .
5. Main clock frequency (f) corresponds to the video sampling frequency.
6. Min, Typ, Max specifications reflect operation at the corresponding Min, Typ, Max clock frequency.
7. Prohibit crossing time is to insure that two start pulses are not supplied in the same scan line time. SP may only be active high during one falling edge of CP for any given scan.
8. Applies to V_{OUT1} , V_{OUT2} , V_{OUT3} and V_{OUT4} which have identical electrical characteristics. The only physical difference is the active scan length of V_{OUT4} which has 64 less pixels.

NOM02A4–MW60G

Table 5. PHYSICAL SPECIFICATIONS

Parameter	Symbol	Typ	Unit
Scan width	PD _w	216	mm
Number of Photo Detector Arrays	PDA _n	27	arrays
Number of Photo Detectors	PD _n	1728	elements
Number of Photo Detectors for VOUT1, VOUT2, VOUT3	PD _{n1,2,3}	448	elements
Number of Photo Detectors for VOUT4	PD _{n4}	384	elements

Table 6. PHYSICAL CHARACTERISTICS

Parameter	Symbol	Min	Typ	Max	Unit
Pixel pitch	PD _{sp}		125		μm
Inter–array spacing	PDA _{sp}	150	180	210	μm
Inter–array vertical alignment	PDA _{vxp}	–40	0	40	μm
White LED chromaticity coordinates	X Y	0.2 0.16	0.24 0.23	0.305 0.31	

Table 7. ELECTRO–OPTICAL CHARACTERISTICS TEST CONDITIONS

Parameter	Symbol	Value	Unit
Power supply voltage	V _{DD}	5.0	V
	V _{SS}	–5.0	V
	V _{LED}	5.0	V
Clock frequency	f	5.0	MHz
Clock pulse high duty cycle	DC _{CP}	25	%
Line scanning rate	T _{int}	90	μs
LED arrays pulsed time on (Note 9)	LED_Ton	26	ms
LED arrays pulsed time off (Note 9)	LED_Toff	356	ms
Operating Temperature	T _{op}	25	°C

9. Production tested with pulsing LEDs.

NOM02A4–MW60G

Table 8. ELECTRO–OPTICAL CHARACTERISTICS (Unless otherwise specified, these specifications were achieved with the test conditions defined in Table 7)

Parameter	Symbol	Min	Typ	Max	Unit
Bright analog output voltage (Note 10)	V_{pavg}	0.9	1.0	1.1	V
Bright output non–uniformity (Note 11)	U_p	–30		30	%
Bright output non–uniformity total (Note 12)	U_{ptotal}			60	%
Adjacent pixel non–uniformity (Note 13)	U_{padj}			25	%
Dark output voltage (Note 14)	V_d			200	mV
Dark non–uniformity (Note 15)	U_d			75	mV
Modulation transfer function at 50 line pairs per in (lp/in) (Note 16)	MTF_{50}	40			%
Modulation transfer function at 100 line pairs per in (lp/in) (Notes 16, 17)	MTF_{100}	20			%

10. $V_{pavg} = \sum V_{p(n)}/1728$, where
 V_p is the pixel amplitude value of V_{OUT} for a bright signal defined as a white document with LEDs turned on,
 n is the sequential pixel number in one scan line.
11. $U_p = [(V_{pmax} - V_{pavg})/V_{pavg}] \times 100\%$, or $[V_{pavg} - V_{pmin})/V_{pavg}] \times 100\%$, whichever is greater, where
 V_{pmax} is the maximum pixel voltage of any pixel at full bright
 V_{pmin} is the minimum pixel voltage of any pixel at full bright
12. $U_{ptotal} = [(V_{pmax} - V_{pmin})/V_{pavg}] \times 100\%$,
13. $U_{padj} = \text{MAX} [| (V_{p(n)} - V_{p(n+1)}) / V_{p(n)} | \times 100\%$, where
 U_{padj} is the nonuniformity in percent between adjacent pixels for a bright background
14. V_d is the pixel amplitude value of V_{OUT} for a dark signal defined as a black document with LEDs turned off
15. $U_d = V_{dmax} - V_{dmin}$, where
 V_{dmax} is the maximum pixel voltage of any dark pixel with the LEDs turned off
 V_{dmin} is the minimum pixel voltage of any dark pixel with the LEDs turned off
16. $MTF = [(V_{max} - V_{min})/(V_{max} + V_{min})] \times 100\%$, where
 V_{max} is the maximum output voltage at the specified line pairs per inch (lp/in)
 V_{min} is the minimum output voltage at the specified lp/in
17. For information only.

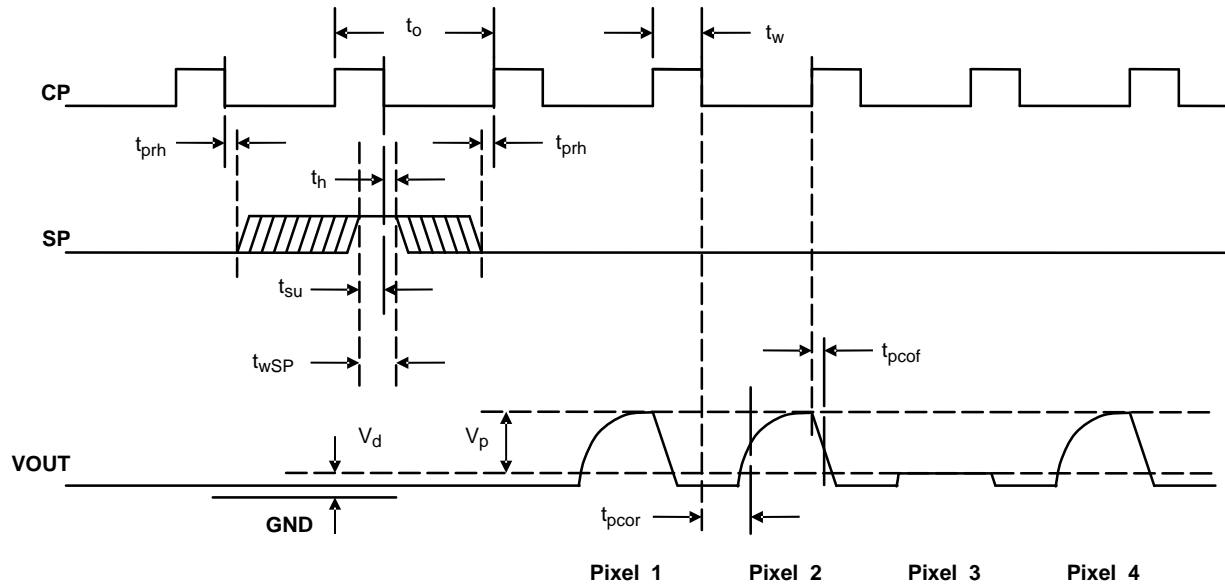

Figure 3. Timing Diagram

DESCRIPTION OF OPERATION

Functional Description

The NOM02A4–MW60G module consists of 27 contact image sensors, each with 64 pixel elements, that are cascaded to provide 1728 photo–detectors with their associated multiplex switches and four double–buffered digital shift registers that control its sequential readout. Four buffer amplifiers amplify the video pixels from the image sensors and output the four analog video signals of the module as shown in Figure 2. In operation, the sensors produce analog image pixel signals (or video signals) proportional to the exposure on the corresponding picture elements on the document. Each of the VOUT1, VOUT2 and VOUT3 signals output 448 pixels for each scan line. The VOUT4 signal outputs 384 valid pixels followed by 64 null pixels for each scan line. The first bit shifted out from VOUT1 during each scan represents the first pixel on the connector end of the module.

A pictorial of the NOM02A4–MW60G cross section view is shown in Figure 4. Mounted in the module is a one–to–one graded–index micro lens array that focuses the scanned document image onto the sensing plane. Illumination is accomplished by means of an integrated LED light source. All components are housed in a small plastic housing, which has a glass cover. The top surface of the glass acts as the focal point for the object being scanned and protects the imaging array, micro lens assembly and LED light source from dust.

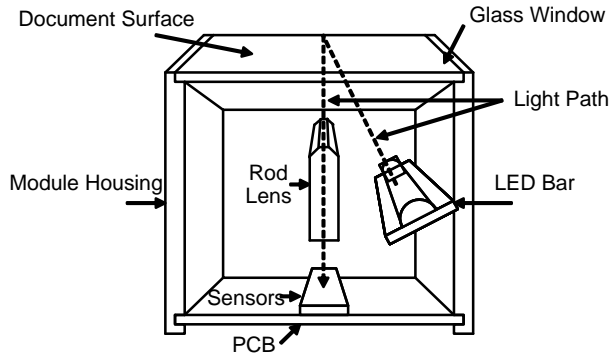

Figure 4. Module Cross Section View

Connector Pin Out Description

Connections to the module are via a 3.5 x 16.75mm 12–pin connector (Molex part number 53048–1210) located at one end of the module as shown in the package drawing on page 8. The location of pin number 1 is indicated on the package drawing.

Scanner Applications

A typical use of the NOM02A4–MW60G module in scanner applications is shown in Figure 6. The document to be digitized is fed into the scanner where a sensor detects its presence. The scanner then operates the motor to move the paper under the contact image sensor module. The module illuminates the paper with internal LEDs and the image sensor pixel array detects the amount of reflected light and simultaneously measures a full line of pixels which are sampled and transferred to a FIFO for storage and conversion to a parallel output format. Once the pixel line is

processed, the motor advances the paper and the next scan line is captured.

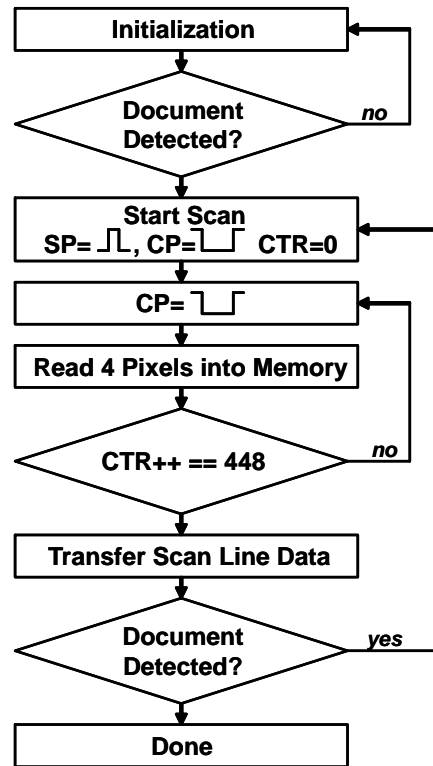

Figure 5. Typical Scanner Algorithm

Figure 5 outlines the basic steps in the scanner control sequence. First the circuits are initialized and the scanner waits for a document to be detected, usually by a paper sensing switch. Then a start pulse and clock pulse are supplied to capture a line image. At the next clock pulse the first pixel value appears on the output. The pixel can be stored in a local line buffer memory. Subsequent clocks cause the remaining pixels to be shifted out and stored in the line buffer. Once the complete line has been shifted out it can be transferred to the host application and the system advances the paper and the line scan process repeats until the paper sensing switch indicates the document has passed completely through the scanner.

Device Marking and Barcode Description

Each module is marked with a tag that contains the part number, a number combining the manufacturing date code and serial number and a barcode. The barcode presents the date code and serial number in Interleave 2 of 5 barcode format as follows

YYMMSSSSSS

where

YY is the year,
MM is the month, and
SSSSSS is the serial number.

Glass Lens Care

Precautions should be taken to avoid scratching or touching the glass lens. The glass lens may be cleaned with alcohol.

NOM02A4-MW60G

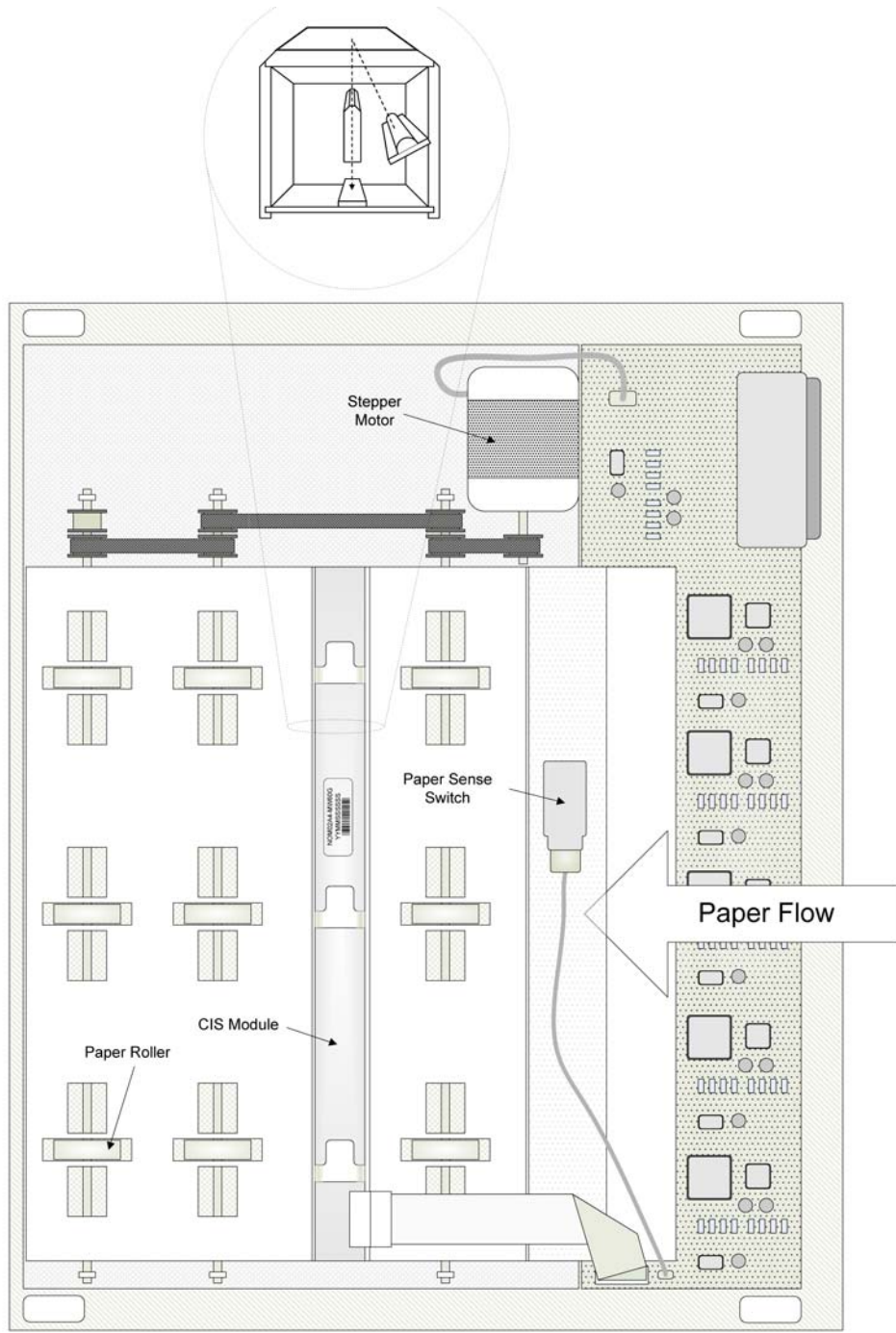
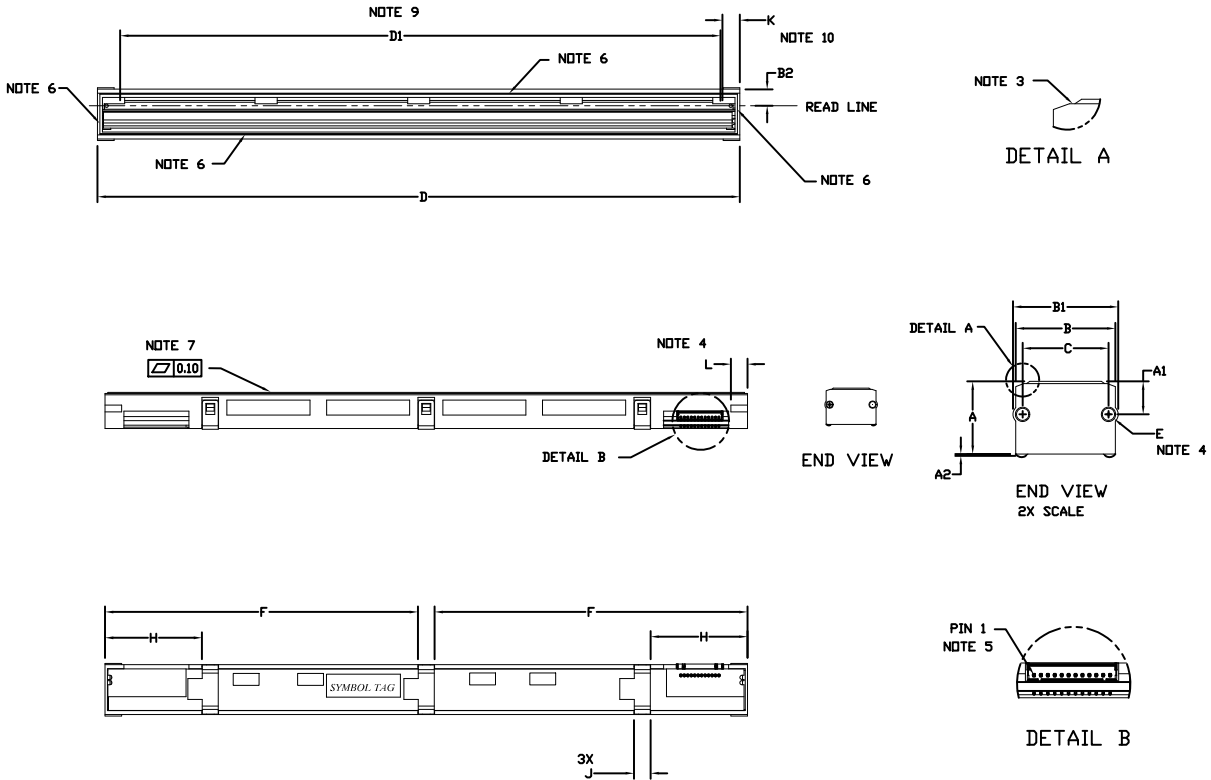

Figure 6. Typical Scanner Assembly

NOM02A4-MW60G

PACKAGE DIMENSIONS

IMAGE SENSOR MODULE A4 CASE MODAB ISSUE B



NOTES:

1. DIMENSIONING AND TOLERANCING PER ASME Y14.5M, 1994.
2. CONTROLLING DIMENSION: MILLIMETERS.
3. LEADING EDGE OF THE APPROACH ANGLE ON THE GLASS IS LOWER THAN THE TOP OF THE HOUSING.
4. BORE DEPTH IS 6.0 WITH A 0.2 LEAD-IN CHAMFER.
5. CONNECTOR ASSEMBLY; MOLEX 53048-1210, 1 X 12 PIN, PITCH 1.25.
6. GLASS IS GLUED ON ALL 4 SIDES.
7. GLASS THICKNESS IS 1.85.
8. USE M2.3 SELF TAPPING SCREWS FOR MOUNTING. TORQUE SCREWS BETWEEN 1.80 KGF-CM AND 2.00 KGF-CM.
9. DIMENSION D1 DENOTES THE SCAN LENGTH.
10. DIMENSION K DENOTES THE POSITION OF THE FIRST PIXEL.

MILLIMETERS		
DIM	MIN	MAX
A	12.60	13.60
A1	5.45	6.45
A2	0.58	REF
B	17.70	18.30
B1	18.70	19.30
B2	5.50	6.50
C	15.30	15.70
D	231.50	232.50
D1	216.00	REF
E	2.15	2.25
F	112.50	113.50
H	34.50	35.50
J	5.70	6.30
K	5.30	7.30
L	6.00	REF

NOM02A4-MW60G

PACKING DIMENSIONS

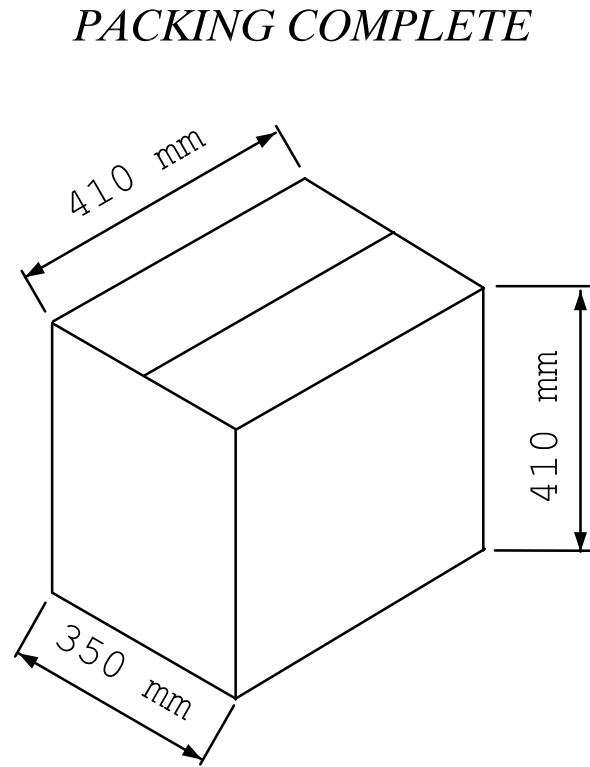
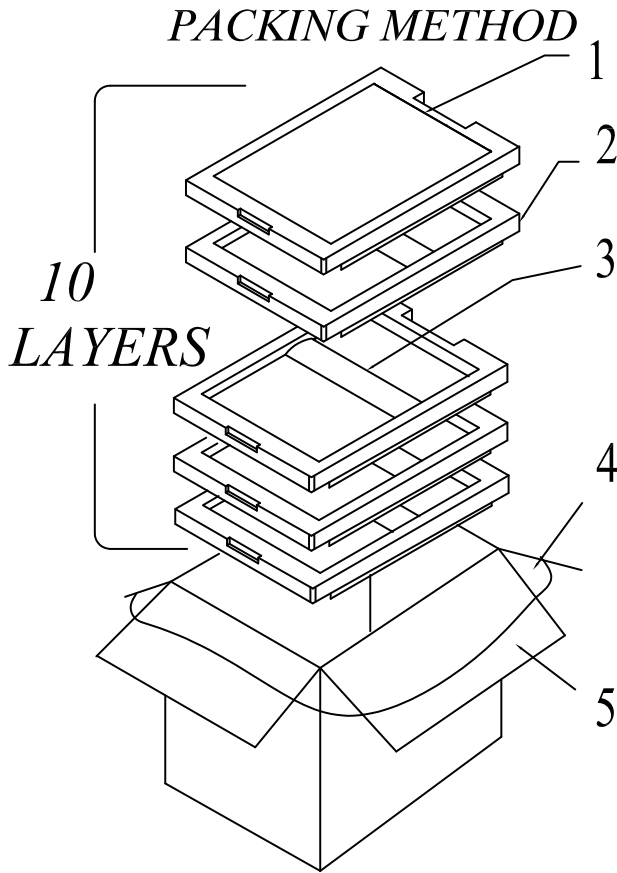

NO.	NAME	MATERIAL
1	Shockproof Pad	EPE
2	Packing Tray	POLYFOAM
3	Conduct Electricity Sheet	PE + CONDUCTIVE SHEET
4	Waterproof Bag	PE
5	Packing Box-Carton	KRAFT PAPER

ON Semiconductor and the  are registered trademarks of Semiconductor Components Industries, LLC (SCILLC) or its subsidiaries in the United States and/or other countries. SCILLC owns the rights to a number of patents, trademarks, copyrights, trade secrets, and other intellectual property. A listing of SCILLC's product/patent coverage may be accessed at www.onsemi.com/site/pdf/Patent-Marking.pdf. SCILLC reserves the right to make changes without further notice to any products herein. SCILLC makes no warranty, representation or guarantee regarding the suitability of its products for any particular purpose, nor does SCILLC assume any liability arising out of the application or use of any product or circuit, and specifically disclaims any and all liability, including without limitation special, consequential or incidental damages. "Typical" parameters which may be provided in SCILLC data sheets and/or specifications can and do vary in different applications and actual performance may vary over time. All operating parameters, including "Typicals" must be validated for each customer application by customer's technical experts. SCILLC does not convey any license under its patent rights nor the rights of others. SCILLC products are not designed, intended, or authorized for use as components in systems intended for surgical implant into the body, or other applications intended to support or sustain life, or for any other application in which the failure of the SCILLC product could create a situation where personal injury or death may occur. Should Buyer purchase or use SCILLC products for any such unintended or unauthorized application, Buyer shall indemnify and hold SCILLC and its officers, employees, subsidiaries, affiliates, and distributors harmless against all claims, costs, damages, and expenses, and reasonable attorney fees arising out of, directly or indirectly, any claim of personal injury or death associated with such unintended or unauthorized use, even if such claim alleges that SCILLC was negligent regarding the design or manufacture of the part. SCILLC is an Equal Opportunity/Affirmative Action Employer. This literature is subject to all applicable copyright laws and is not for resale in any manner.

PUBLICATION ORDERING INFORMATION

LITERATURE FULFILLMENT:

Literature Distribution Center for ON Semiconductor
P.O. Box 5163, Denver, Colorado 80217 USA
Phone: 303-675-2175 or 800-344-3860 Toll Free USA/Canada
Fax: 303-675-2176 or 800-344-3867 Toll Free USA/Canada
Email: orderlit@onsemi.com

N. American Technical Support: 800-282-9855 Toll Free
USA/Canada
Europe, Middle East and Africa Technical Support:
Phone: 421 33 790 2910
Japan Customer Focus Center
Phone: 81-3-5817-1050

ON Semiconductor Website: www.onsemi.com

Order Literature: <http://www.onsemi.com/orderlit>

For additional information, please contact your local Sales Representative