

THIS DOCUMENT IS THE PROPERTY OF KEYSTONE ELECTRONICS CORP. AND SHALL NOT BE REPRODUCED, DISTRIBUTED OR USED AS A BASIS FOR MANUFACTURE WITHOUT PRIOR WRITTEN PERMISSION FROM KEYSTONE ELECTRONICS CORP.

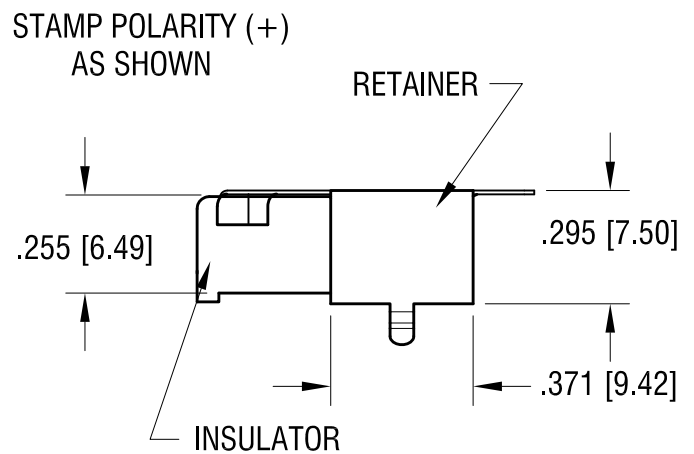
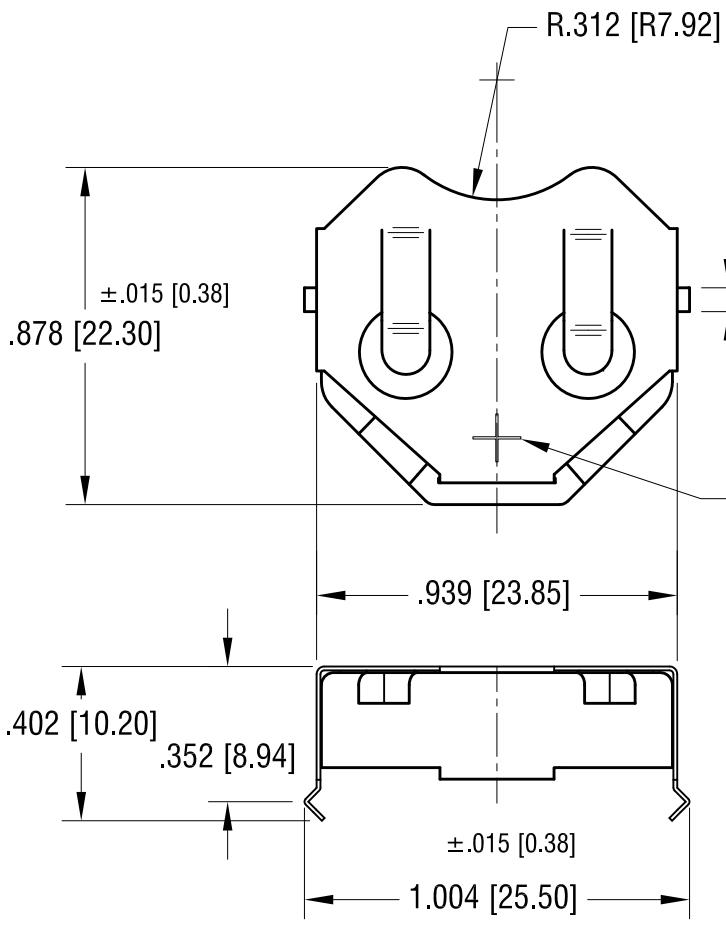
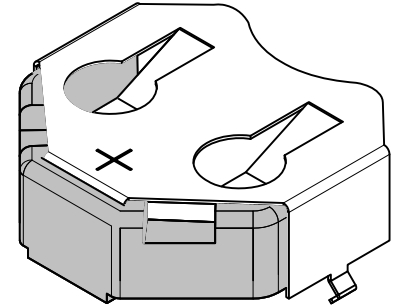
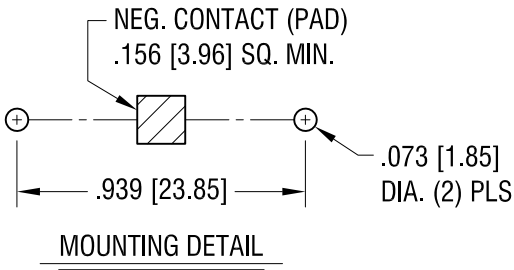

NOTE:

1. CLIP MAT'L: .010 TH'K FULL HARD PHOSPHOR BRONZE
INSULATOR MAT'L: HIGH TEMPERATURE NYLON, UL 94V-0
2. CLIP FINISH: TIN NICKEL PLATE

KEYSTONE ELECTRONICS CORP.

www.keyelco.com • ASTORIA, N.Y. 11105-2017 • Tel (718) 956-8900

PART NAME			
THM COIN CELL CLIP FOR TWO 2032			
MATERIAL			
AS NOTED			
FINISH		DRN BY	DATE
AS NOTED		NT	6.01.10
		APP'D	SCALE
		LN	2X
TOLERANCES	INCH [MM]	CODE	DWG NO.
DECIMAL	±.010 [±0.25]	C	3025
ANGULAR	± 1°		
UNLESS OTHERWISE SPECIFIED			

DATE	DESCRIPTION	REV.
------	-------------	------