

NOTES:

1. MATERIALS AND FINISHES:
 BODY - BRASS, NICKEL PLATING
 HOUSING - BRASS, GOLD PLATING
 CONTACT - BeCu, GOLD PLATING
 INSULATOR - PTFE
2. ELECTRICAL:
 A. IMPEDANCE: 75 OHMS
 B. FREQUENCY RANGE: DC - 4.5 GHz
 C. RETURN LOSS : 25 dB MIN AT 3 GHz
 D. DIELECTRIC WITHSTANDING VOLTAGE: 1000 VRMS, MIN.
 E. INSULATION RESISTANCE: 10,000 MEGOHMS MIN
 F. VOLTAGE RATING: 335 VRMS
3. MECHANICAL:
 A. DURABILITY: 500 CYCLES MIN.
4. ENVIRONMENTAL:
 A. THERMAL SHOCK PER MIL-STD-202 METHOD 107
 TEST CONDITION B (EXCEPT HIGH TEMP @200° C)
 B. VIBRATION: MIL-STD-202 METHOD 204 TEST CONDITION B
 C. SHOCK: MIL-STD-202 METHOD 213 TEST CONDITION B
 D. CORROSION: MIL-STD-202 METHOD 101
 TEST CONDITION B 5% SALT SOLUTION
5. PACKAGING:
 A. QUANTITY: SINGLE PACK
 B. MARKING: BAG TO BE MARKED
 "AMPHENOLRF, 34-1030, AND DATE CODE"

THIRD ANGLE PROJ.

REVISIONS

REV	DESCRIPTION	DATE	ECO	APPR
1	PROTOTYPE RELEASE	06-Apr-10	--	AAP
2	A) UPDATED NOTES B) ADDED SHEETS TO DEFINE LAUNCH	19-May-10	--	NMV

PRELIMINARY ISSUE

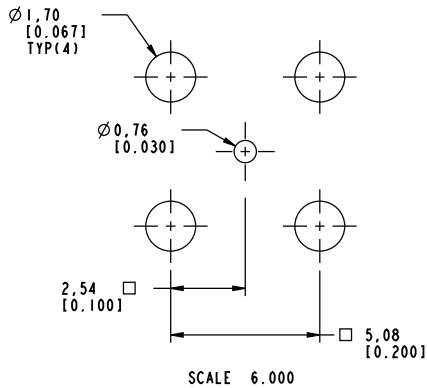
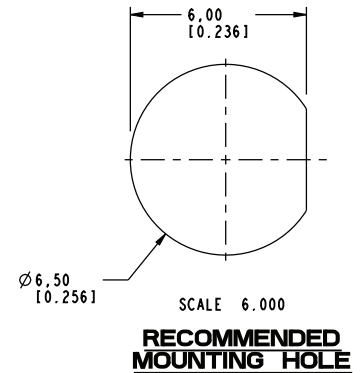
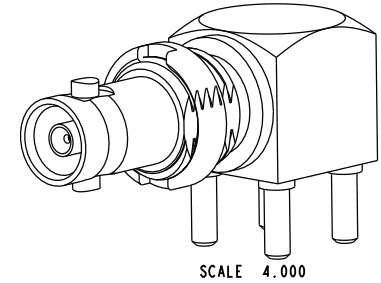
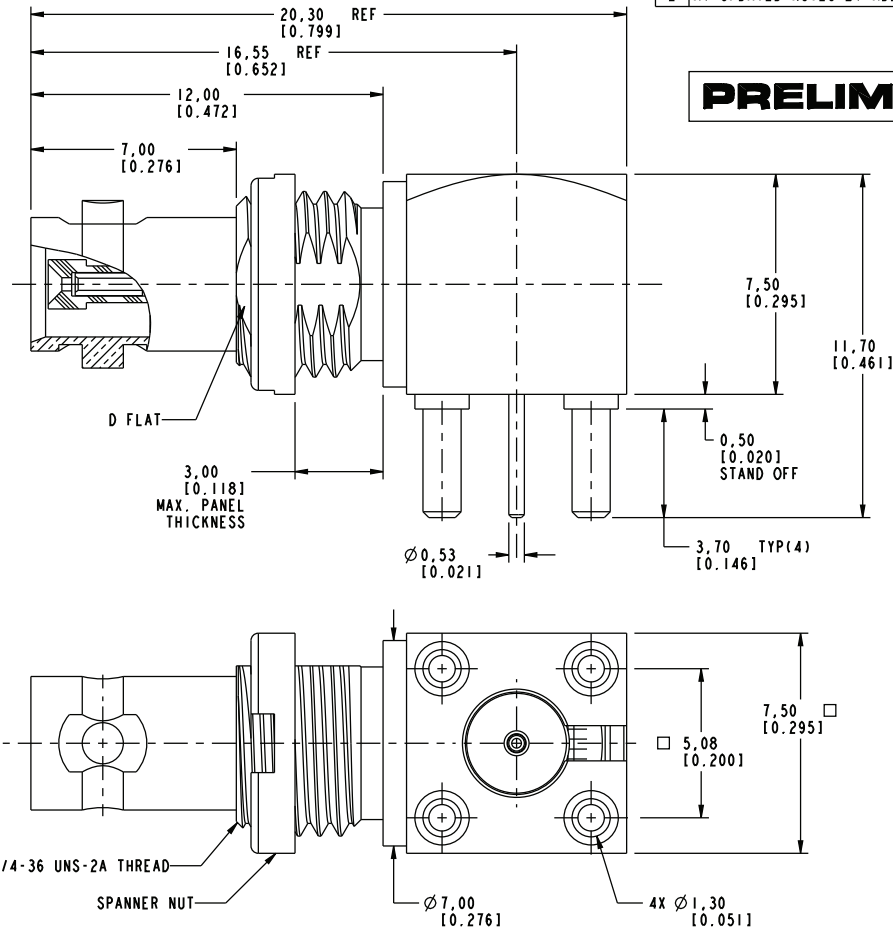

CUSTOMER OUTLINE DRAWING
 ALL OTHER SHEETS ARE FOR INTERNAL USE ONLY

UNLESS OTHERWISE SPECIFIED, DIMENSIONS ARE IN METRIC AND TOLERANCES ARE:
 <0.5mm ±0.05mm 0.5 - 6mm ±0.1mm 6 - 30mm ±0.2mm 30 - 120mm ±0.3mm ANGLES ±1°

NOTICE - These drawings, specifications, or other data (1) are, and remain the property of Amphenol corp. (2) must be returned upon request; and (3) are confidential and not to be disclosed to any person other than those to whom they are given by Amphenol Corp. The finishing of these drawings, specifications, or other data by Amphenol Corp., or to any other person to anyone for any purpose is not to be regarded by implication or otherwise in any manner licensing, granting rights to permitting such holder or any other person to manufacture, use or sell any product, process or design, patented or otherwise, that may in any way be related to or disclosed by said drawings, specifications, or other data.

MATERIAL SEE NOTES	DRAWN NISCHIT MV	DATE 09-Apr-10	TITLE HD BNC RA BHD JACK PCB MOUNT	Amphenol RF Danbury CT USA, Tainan, Taiwan, Shenzhen, China www.amphenolrf.com
	ENGINEER NISCHIT MV	DATE 09-Apr-10		
REFERENCE EAR # 4028	APPROVED	DATE	SCALE: 6.0:1.0	SHEET 2 OF 4
CONFIGURATION LEVEL: Prototype	CAD FILE	Root Folder/HD-BNC/34-1030	DWG SIZE B	REV 2
FINISH				DRAWING NO. 34-1030 ITEM NO. 34-1030 PART NO. 34-1030

THIRD ANGLE PROJ.

REVISIONS

REV	DESCRIPTION	DATE	ECO	APPR
2	PROTOTYPE RELEASE	19-May-10	--	NMV

PRELIMINARY ISSUE

RECOMMENDED PCB LAUNCH FOR OPTIMAL RF PERFORMANCE

VARIATIONS IN BOARD SUBSTRATE AND TRACE MAY REQUIRE DIFFERENT GEOMETRY

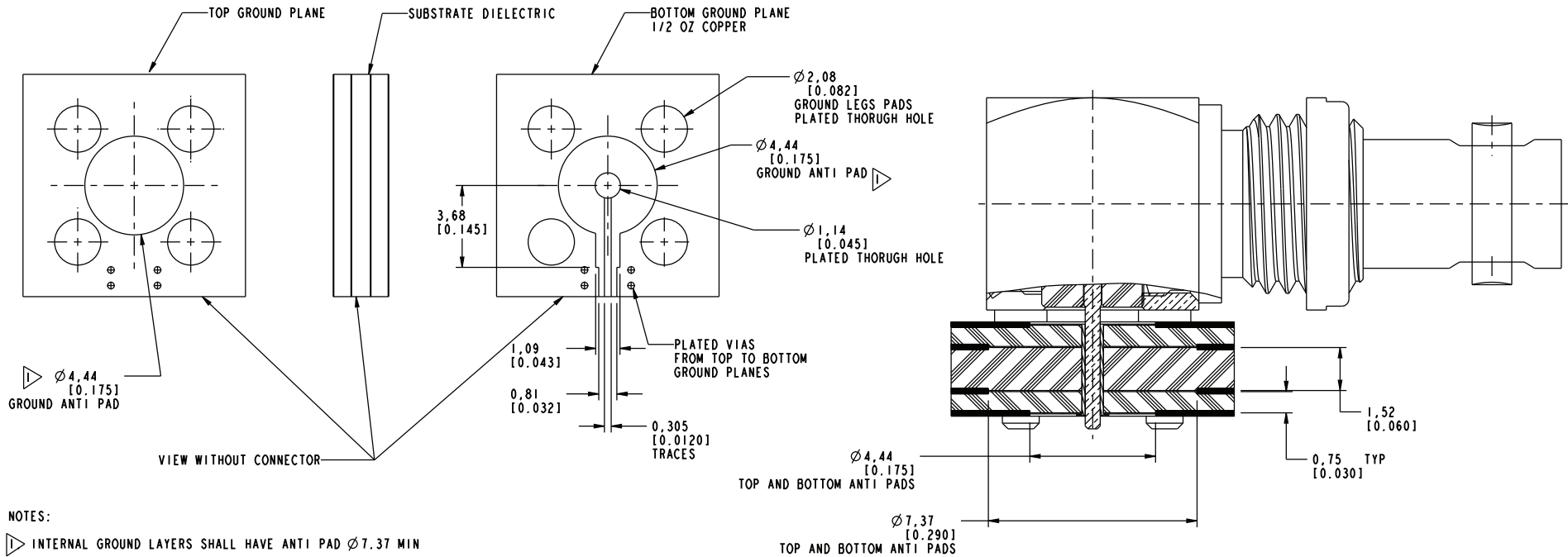

NOTES:

INTERNAL GROUND LAYERS SHALL HAVE ANTI PAD Ø 7.37 MIN

UNLESS OTHERWISE SPECIFIED, DIMENSIONS ARE IN METRIC AND TOLERANCES ARE:
 <0.5mm ±0.05mm 0.5 - 6mm ±0.1mm 6 - 30mm ±0.2mm 30 - 120mm ±0.3mm ANGLES ±1°

NOTICE - These drawings, specifications, or other data (1) are, and remain the property of Amphenol Corp. (2) must be returned upon request; and (3) are confidential and not to be disclosed to any person other than those to whom they are given by Amphenol Corp. The furnishing of these drawings, specifications, or other data by Amphenol Corp., or to any other person to anyone for any purpose is not to be regarded by implication or otherwise in any manner licensing, granting rights to permitting such holder or any other person to manufacture, use or sell any product, process or design, patented or otherwise, that may in any way be related to or disclosed by said drawings, specifications, or other data.

MATERIAL	DRAWN NISCHIT MV	DATE 20-May-10	TITLE HD BNC RA BHD JACK PCB MOUNT	Amphenol RF Danbury CT USA, Tainan, Taiwan, Shenzhen, China www.amphenolrf.com
REFERENCE EAR # 4028 AND	ENGINEER NISCHIT MV	DATE 20-May-10		
CONFIGURATION LEVEL: Prototype	APPROVED	DATE	SCALE: 0.8:1.0	SHEET 3 OF 4
FINISH	CAD FILE Root Folder/HD-BNC/34-1030	DWG SIZE B	REV 2	DRAWING NO. 34-1030
				ITEM NO. 34-1030
				PART NO. 34-1030

THIRD ANGLE PROJ.

REVISIONS

REV	DESCRIPTION	DATE	ECO	APPR
2	BACK END DESIGN UPDATED	19-May-10	--	NMV

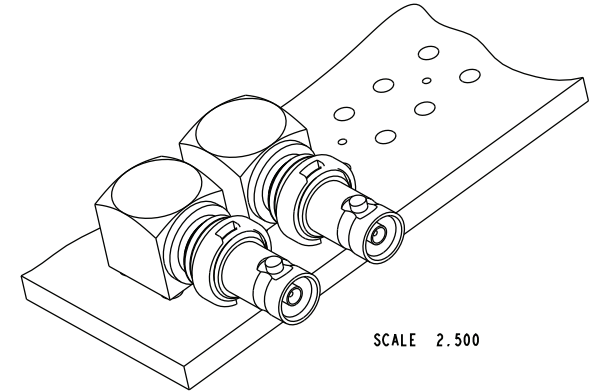
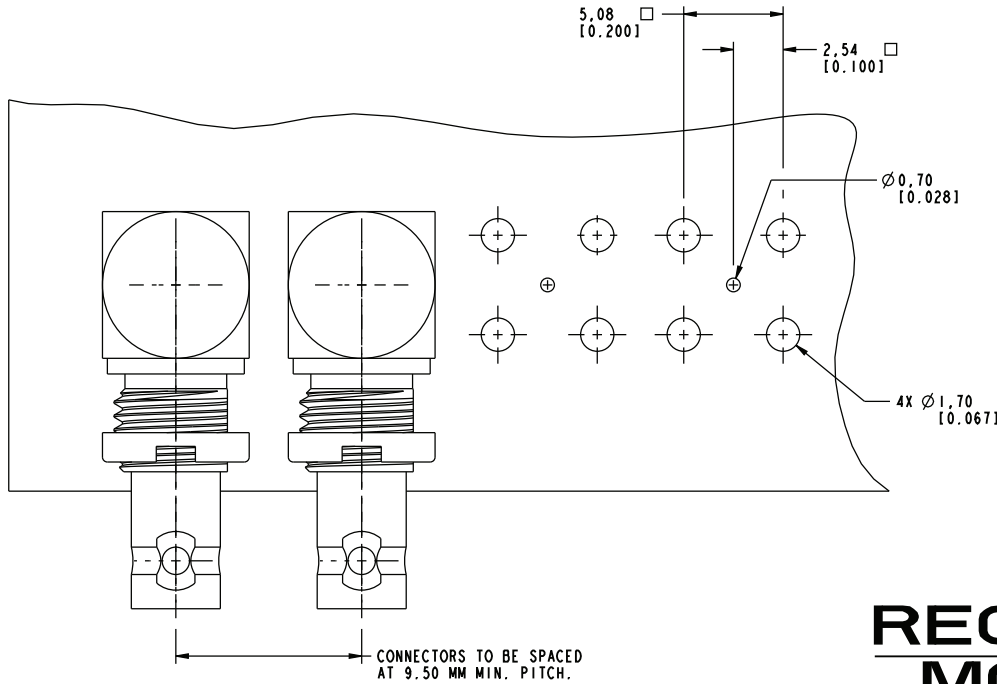

RECOMMENDED PCB MOUNTING HOLES

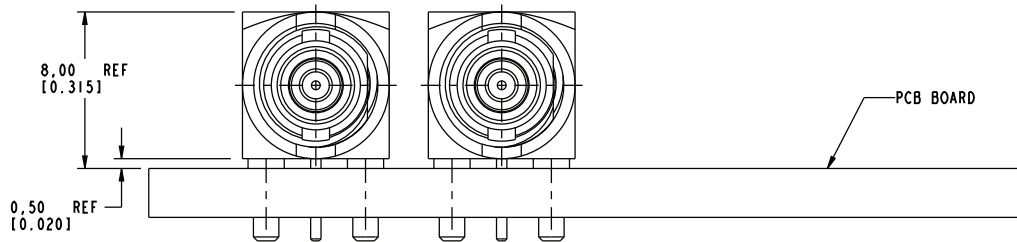

PRELIMINARY ISSUE

CUSTOMER OUTLINE DRAWING
ALL OTHER SHEETS ARE FOR INTERNAL USE ONLY

<p>UNLESS OTHERWISE SPECIFIED, DIMENSIONS ARE IN METRIC AND TOLERANCES ARE: <0.5mm ±0.05mm 0.5 - 6mm ±0.1mm 6 - 30mm ±0.2mm 30 - 120mm ±0.3mm ANGLES ±1°</p> <p>NOTICE - These drawings, specifications, or other data (1) are, and remain the property of Amphenol Corp. (2) must be returned upon request; and (3) are confidential and not to be disclosed to any person other than those to whom they are given by Amphenol Corp. The furnishing of these drawings, specifications, or other data by Amphenol Corp., or to any other person to anyone for any purpose is not to be regarded by implication or otherwise in any manner licensing, granting rights to permitting such holder or any other person to manufacture, use or sell any product, process or design, patented or otherwise, that may in any way be related to or disclosed by said drawings, specifications, or other data.</p>	<p>MATERIAL</p> <p>-</p>	<p>DRAWN</p> <p>NISCHIT MV</p>	<p>DATE</p> <p>20-May-10</p>	<p>TITLE</p> <p>HD BNC RA BHD JACK PCB MOUNT</p>	<p>Amphenol RF</p> <p>Danbury CT USA, Tainan, Taiwan, Shenzhen, China www.amphenolrf.com</p>
	<p>REFERENCE</p> <p>EAR # 4028 AND</p> <p>CONFIGURATION LEVEL: Prototype</p>	<p>ENGINEER</p> <p>NISCHIT MV</p>	<p>DATE</p> <p>20-May-10</p>		
<p>FINISH</p>	<p>APPROVED</p>	<p>DATE</p>	<p>REV</p> <p>2</p>	<p>ITEM NO. 34-1030</p>	<p>PART NO. 34-1030</p>
<p>Root Folder/HD-BNC/34-1030</p>					