

PRODUCT NUMBER	DESCRIPTION	NOTES
10117950-XXXXLF	NON-HF	SEE SHT. 3
10117950-XXXXHLF	HALOGEN FREE (H)	SEE SHT. 3



dr	Deborah Ingram	2011/11/16	projection	mm	size	A3	scale	4:5
eng	Tom Feng	2016/06/15			ecn no	ELX-N-24288-1		
chr	-	-			rel level	Released		
appr	Michael Zhou	2016/09/22	product family	C&A				
Amphenol FCI		FINAL ASSEMBLY (PASSIVE) MSAS HD 8X ASSEMBLY (12 Gbps)			dwg no 10117950	rev E		
www.fci.com		cat. no.	-		Product - Customer Drw		sheet 1 of 4	

PRODUCT NUMBER	DESCRIPTION
10117950-XXXXLF	NON-HF
10117950-XXXXHLF	HALOGEN FREE (H)

P1-(A) TO P2-(A)
P1-(B) TO P2-(B)

WIRING LIST (SEE NOTE 6)

END P1 / (A) (B)		END P2 / (A) (B)	
POSITION	SYMBOL	POSITION	SYMBOL
D9	GROUND	B9	GROUND
D8	Tx2-	B8	Rx2-
D7	Tx2+	B7	Rx2+
D6	GROUND	B6	GROUND
D5	Tx0-	B5	Rx0-
D4	Tx0+	B4	Rx0+
D3	GROUND	B3	GROUND
D2	Vman	B2	ModPrsL
D1	Vact	B1	Vact
C1	SCL	A1	Reserved
C2	SDA	A2	IntL
C3	GROUND	A3	GROUND
C4	Tx1+	A4	Rx1+
C5	Tx1-	A5	Rx1-
C6	GROUND	A6	GROUND
C7	Tx3+	A7	Rx3+
C8	Tx3-	A8	Rx3-
C9	GROUND	A9	GROUND
B9	GROUND	D9	GROUND
B8	Rx2-	D8	Tx2-
B7	Rx2+	D7	Tx2+
B6	GROUND	D6	GROUND
B5	Rx0-	D5	Tx0-
B4	Rx0+	D4	Tx0+
B3	GROUND	D3	GROUND
B2	ModPrsL	D2	Vman
B1	Vact	D1	Vact
A1	Reserved	C1	SCL
A2	IntL	C2	SDA
A3	GROUND	C3	GROUND
A4	Rx1+	C4	Tx1+
A5	Rx1-	C5	Tx1-
A6	GROUND	C6	GROUND
A7	Rx3+	C7	Tx3+
A8	Rx3-	C8	Tx3-
A9	GROUND	C9	GROUND

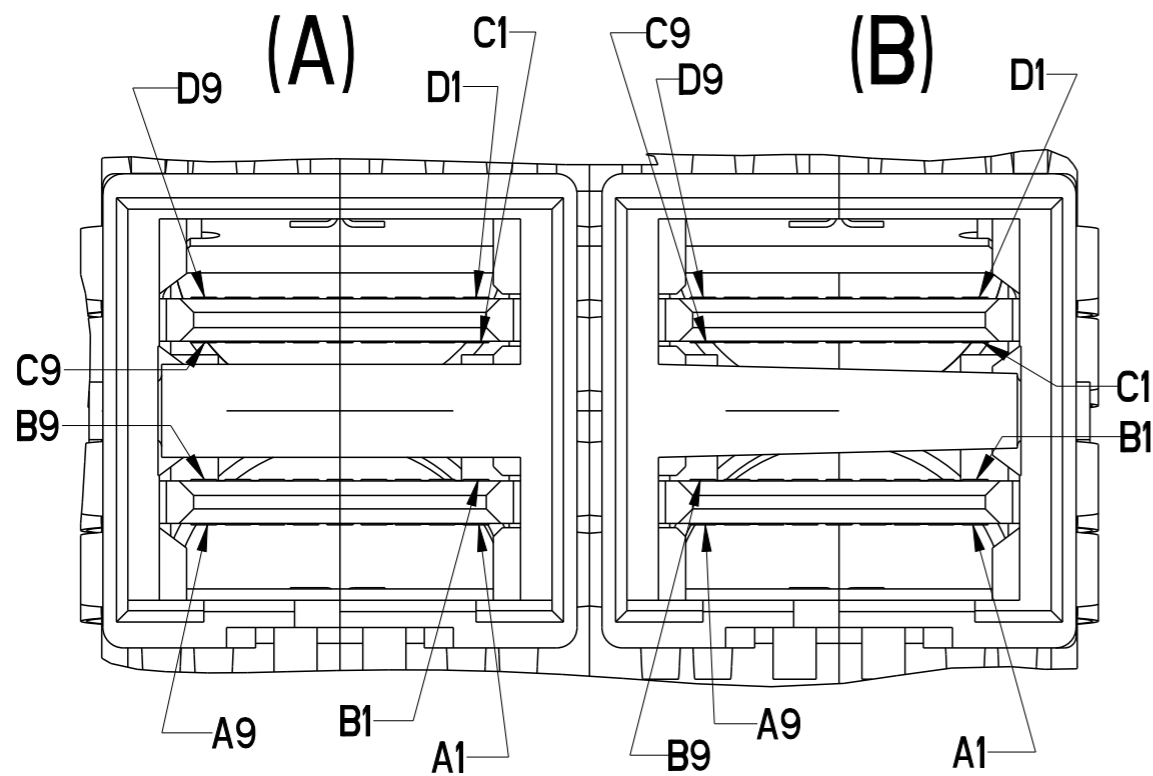

VIEW A (END P1)
SCALE 6:1

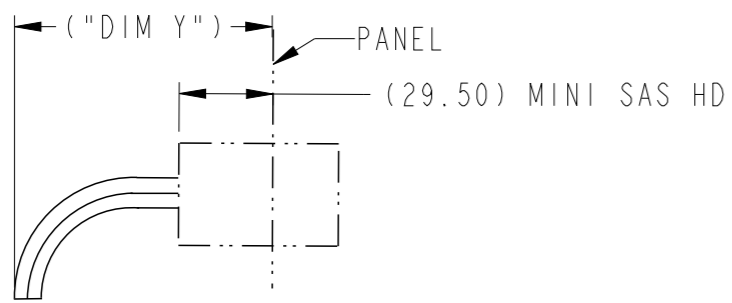

BEND RADIUS
TOP VIEW OF CONNECTOR

MINI SAS HD MINIMUM CABLE BEND TABLE		
CABLE	("DIM Y") HF	("DIM Y") (NON-HF)
24 AWG	101.2	101.2
26 AWG	95	92.2
28 AWG	88	85.2
30 AWG	83.8	79.6

LENGEND:

	HIGH-SPEED SERIAL DIFFERENTIAL PAIRS
	SIGNAL RETURN
	POWER AND MANAGEMENT INTERFACE

SHIELD-----SHIELD

dr	Deborah Ingram	2011/11/16	projection	mm	size	A3	scale	1:1		
eng	Tom Feng	2016/06/15		← →	ecn no	ELX-N-24288-1	rel level	Released		
chr	-	-								
appr	Michael Zhou	2016/09/22	product family	C&A						
Amphenol FCI			FINAL ASSEMBLY (PASSIVE)			dwg no		10117950	rev	E
www.fci.com			MSAS HD 8X ASSEMBLY (12 Gbps)			cat. no.		-	Product - Customer Drw	

△ PART NUMBER (NON-HALOGEN FREE) SEE NOTE 12 AND 16	LENGTH "DIM L" (Meters)	LENGTH "DIM N" (Meters)	("DIM M") (mm)	AWG
10117950-2004LF	(0.43)	0.33	17.3	30
10117950-2005LF	0.5		17.3	30
10117950-2010LF	1.0		17.3	30
10117950-2015LF	1.5		17.3	30
10117950-2020LF	2.0		17.3	30
10117950-3010LF	1.0		17.3	28
10117950-3015LF	1.5		17.3	28
10117950-3020LF	2.0		17.3	28
10117950-3025LF	2.5		17.3	28
10117950-3030LF	3.0		17.3	28
10117950-4010LF	1.0		20.1	26
10117950-4015LF	1.5		20.1	26
10117950-4020LF	2.0		20.1	26
10117950-4025LF	2.5		20.1	26
10117950-4030LF	3.0		20.1	26
10117950-4035LF	3.5		20.1	26
10117950-4040LF	4.0		20.1	26
10117950-4045LF	4.5		20.1	26
10117950-4050LF	5.0		20.1	26
10117950-4055LF	5.5		20.1	26
10117950-4060LF	6.0		20.1	26
10117950-5010LF	1.0		20.1	24
10117950-5015LF	1.5		20.1	24
10117950-5020LF	2.0		20.1	24
10117950-5025LF	2.5		20.1	24
10117950-5030LF	3.0		20.1	24
10117950-5035LF	3.5		20.1	24
10117950-5040LF	4.0		20.1	24
10117950-5045LF	4.5		20.1	24
10117950-5050LF	5.0		20.1	24
10117950-5055LF	5.5		20.1	24
10117950-5060LF	6.0		20.1	24
10117950-5065LF	6.5		20.1	24
10117950-5070LF	7.0		20.1	24
10117950-5075LF	7.5		20.1	24
10117950-5080LF	8.0		20.1	24

10117950-5090HLF ONLY USE EXT MSHD INTERFACE DON'T MEET SAS3.0 APPLICATION	9.0		20.1	24
10117950-5100HLF ONLY USE EXT MSHD INTERFACE DON'T MEET SAS3.0 APPLICATION	10.0		20.1	24

△ PART NUMBER (HALOGEN FREE) SEE NOTE 11 AND 16	LENGTH "DIM L" (Meters)	LENGTH "DIM N" (Meters)	("DIM M") (mm)	AWG
10117950-2004HLF	(0.43)	0.33	17.3	30
10117950-2005HLF	0.5		17.3	30
10117950-2010HLF	1.0		17.3	30
10117950-2015HLF	1.5		17.3	30
10117950-2020HLF	2.0		17.3	30
10117950-3010HLF	1.0		17.3	28
10117950-3015HLF	1.5		17.3	28
10117950-3020HLF	2.0		17.3	28
10117950-3025HLF	2.5		17.3	28
10117950-3030HLF	3.0		17.3	28
10117950-4010HLF	1.0		20.1	26
10117950-4015HLF	1.5		20.1	26
10117950-4020HLF	2.0		20.1	26
10117950-4025HLF	2.5		20.1	26
10117950-4030HLF	3.0		20.1	26
10117950-4035HLF	3.5		20.1	26
10117950-4040HLF	4.0		20.1	26
10117950-4045HLF	4.5		20.1	26
10117950-4050HLF	5.0		20.1	26
10117950-4055HLF	5.5		20.1	26
10117950-4060HLF	6.0		20.1	26
10117950-5010HLF	1.0		20.1	24
10117950-5015HLF	1.5		20.1	24
10117950-5020HLF	2.0		20.1	24
10117950-5025HLF	2.5		20.1	24
10117950-5030HLF	3.0		20.1	24
10117950-5035HLF	3.5		20.1	24
10117950-5040HLF	4.0		20.1	24
10117950-5045HLF	4.5		20.1	24
10117950-5050HLF	5.0		20.1	24
10117950-5055HLF	5.5		20.1	24
10117950-5060HLF	6.0		20.1	24
10117950-5065HLF	6.5		20.1	24
10117950-5070HLF	7.0		20.1	24
10117950-5075HLF	7.5		20.1	24
10117950-5080HLF	8.0		20.1	24
10117950-5090HLF ONLY USE EXT MSHD INTERFACE DON'T MEET SAS3.0 APPLICATION	9.0		20.1	24
10117950-5100HLF ONLY USE EXT MSHD INTERFACE DON'T MEET SAS3.0 APPLICATION	10.0		20.1	24

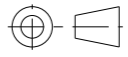
dr	Deborah Ingram	2011/11/16	projection 	size A3	scale 1:1
eng	Tom Feng	2016/06/15			
chr	-	-	product family C&A	ecn no ELX-N-24288-1	rel level Released
appr	Michael Zhou	2016/09/22			
Amphenol FCI		FINAL ASSEMBLY (PASSIVE)		dwg no 10117950	
www.fci.com		MSAS HD 8X ASSEMBLY (12 Gbps)		rev E	
cat. no.		-		Product - Customer Drw	
				sheet 3 of 4	

Amphenol FCI

© 2016 AFCI



PRODUCT NUMBER	DESCRIPTION
10117950-XXXXLF	NON-HF
10117950-XXXXHLF	HALOGEN FREE (H)

NOTES:

- MATERIAL:
 BACK SHELLS: ZINC ALLOY/ COPPER UNDERPLATE/ NICKEL OVERPLATE
 PULL TAB: THERMOPLASTIC POLYMER
 LATCH : STAINLESS STEEL
 FERRULE: BRASS
 EMI SKIRT: STAINLESS STEEL
 LOCTITE
 PADDLE CARD: PRINTED CIRCUIT SUBSTRATE
 HEAT SHRINK TUBE: POLYOLEFIN
- THIS PRODUCT MEETS THE RESTRICTION OF HAZARDOUS SUBSTANCES IN ELECTRICAL AND ELECTRONIC EQUIPMENT (RoHS) DIRECTIVE (2011/65/EU)

- THIS DIMENSION IS A FINISHED PRODUCT LENGTH.
- UNLESS OTHERWISE SPECIFIED ASSEMBLED LENGTH TOLERANCE IS TO BE:
 "DIM L" < 1 METER = ±25mm
 "DIM L" 1 METER TO 4 METERS = ± 2% OF "DIM L"
 "DIM L" > 4 METERS = +0.00/-4% OF "DIM L"

5. LABEL DETAILS:

△ D	MANUFACTURER CODE OR NAME	COUNTRY ORIGIN
	FCI P/N	
	FCI CUSTOMER DRAWING REVISION	
	FCI SERIAL NUMBER	
	BAR CODE OF SERIAL NUMBER	

FONT SHALL BE CLEARLY VISIBLE AND BLACK IN COLOR.

SERIAL NUMBER IS ONLY USED FOR TRACKING PRODUCT,DETAIL IS AS BELOW :



CABLE LABEL EXAMPLE:

FCI	CHINA
10117950-2005LF	
REV.E	
CN1352HK052L0001	

- ALL CABLE ASSEMBLIES 100% TESTED FOR CONTINUITY AS DEFINED IN WIRING LIST.
- PLACE A CABLE TIE EVERY 0.5 METER ON ALL ASSEMBLIES, UNLESS OTHERWISE SPECIFIED. IN CASE OF 0.5 METER CABLE ASSEMBLY, CABLE TIE IS TO BE APPLIED AT THE MIDWAY POINT.
- OTHER TESTING PERFORMED AS REQUIRED BY PRODUCT SPECIFICATION: GS-12-651.
- PACKAGING OF LEAD FREE PRODUCTS MEETS LABELING AND PACKAGING PER SPECIFICATION GS-14-920. PACKAGE CABLE ASSEMBLIES PER GS-14-1272. DUST COVERS ARE TO BE ASSEMBLED PRIOR TO PACKAGING. FCI PACKAGE TRACKING BAG LABEL IS ONLY FOR REFERENCE.

NOTES CONTINUED:

- A "△" SYMBOL WILL BE NEXT TO ANY DIMENSION, VIEW, OR NOTE WHICH HAS BEEN MODIFIED WITH THE CURRENT DRAWING REVISION. THE CURRENT REVISION WILL BE SHOWN IN THE SYMBOL.
- "H" PRODUCT NUMBERS DESIGNATE THE USE OF HALOGEN FREE RAW CABLE.
- HALOGEN FREE RAW CABLE CAN BE USED AS A SUBSTITUTE ON NON-HF PRODUCT NUMBERS.
- CABLE ASSEMBLY CAN MEET SAS 3.0 SPECIFICATION.
- MATES TO SERIES: 10112626 or 10112627 Or 10112628
- EEPROM INFORMATION REFER TO FCI LATEST PRODUCT SPEC. GS-12-651.
- CABLE IS OPTIONAL, WHICH HAD BEEN QUALIFIED BY FCI AND MEET FCI PRODUCT SPEC. GS-12-651.

dr	Deborah Ingram	2011/11/16	projection 	mm ←→	size	A3	scale	1:2
eng	Tom Feng	2016/06/15			ecn no	ELX-N-24288-1		
chr	-	-			rel level	Released		
appr	Michael Zhou	2016/09/22	product family	C&A				
Amphenol FCI		FINAL ASSEMBLY (PASSIVE)			dwg no	10117950	rev	E
www.fci.com		cat. no.	-	Product - Customer Drw		sheet 4 of 4		