

To be read in conjunction with "Introduction to Pellistor Gas Sensors" and Pellistor Application Notes 1, 2, 3, 4, 6 and 7.

INTRODUCTION

The VQ22 is an improved poison-resistant sensor consisting of two matched elements which are used for the detection of combustible gases, particularly methane in air mixtures in concentrations from 0.1% upwards. There is no interference from water vapour or carbon dioxide. Using the recommended bridge circuit below and the mounting arrangement shown on page 3, the minimum sensitivity is 10 mV/% methane.

The VQ22 has been designed for use in atmospheres where traces of silicone and other poisoning agents may be present.

GENERAL DATA

Electrical

The information given below relates to the VQ22 operating in the recommended circuit shown.

Operation (see note 1)	continuous
Bridge supply	2.0 ± 0.1 V
Bridge power consumption	0.48 W max
Typical average sensor current	175 mA
Minimum sensitivity (see note 2)	10 mV/% methane
Linearity	linear up to 5% methane
Response time to register $1\frac{1}{4}\%$ in a $2\frac{1}{2}\%$ concentration (see notes 2 and 3)	2 seconds
Maximum methane concentration (see note 4)	5 %

Mechanical

Mounting	see page 3
Outline	see page 2

MARKING

Each element is identified by a unique serial number written on the can of both the detector and compensator. The serial number is written in red on the detector and black on the compensator. In addition, the detector carries a red circular label on the base identifying the device type.

NOTES

1. Operation may be under either direct flow or diffusion conditions in appropriate mountings (see page 3).
2. With open-circuit conditions at the bridge output.
3. The response time is a function of the type of mounting used.
4. If the VQ22 is exposed to greater than 5% methane concentration, the calibration of the instrument should be checked.
5. The elements are supplied as a matched pair with a trimming resistor R of the correct value which is supplied where necessary. The trimming resistor is to be connected across the compensator element as shown below.
6. The resistance to poisoning by silicone compounds is partly dependent upon the type of housing within which the elements are mounted.
7. The response to certain of the heavy flammable vapours, especially aromatic substances with side chains, may be lower than that calculated from the conversion (K) factors listed in the preamble.

BRIDGE CIRCUIT

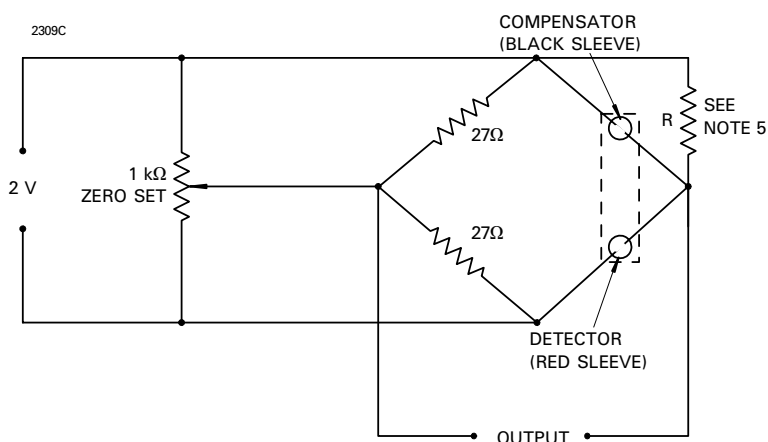

TYPICAL RESPONSE OF VQ22 TO 20% L.E.L. OF VARIOUS GASES AND VAPOURS (RELATIVE TO METHANE) AS THE BRIDGE SUPPLY VOLTAGE IS VARIED

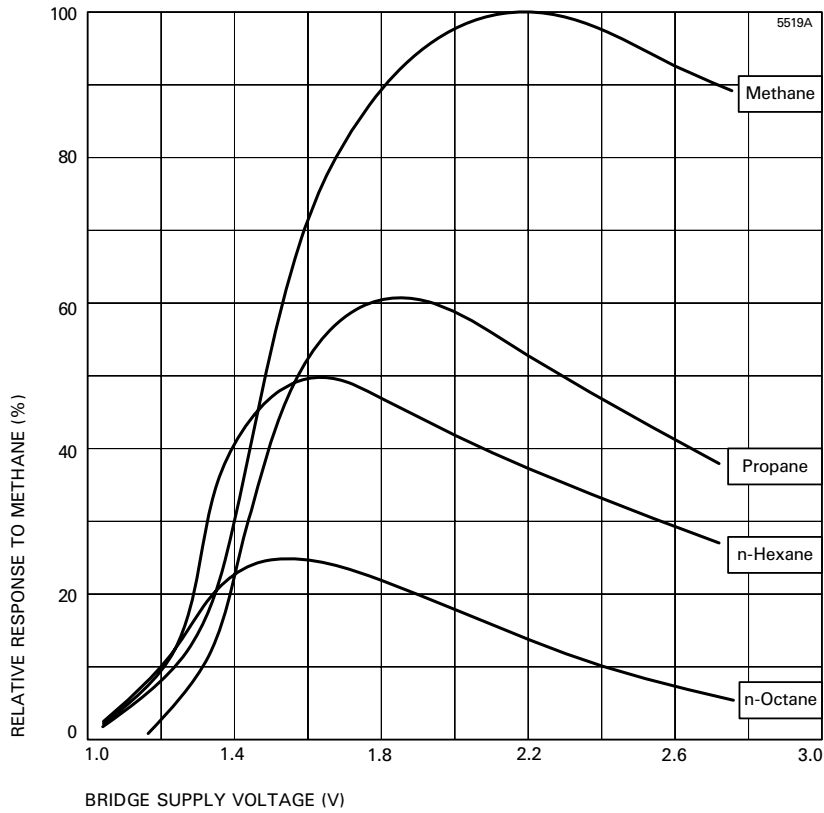

OUTLINE (All dimensions without limits are nominal)

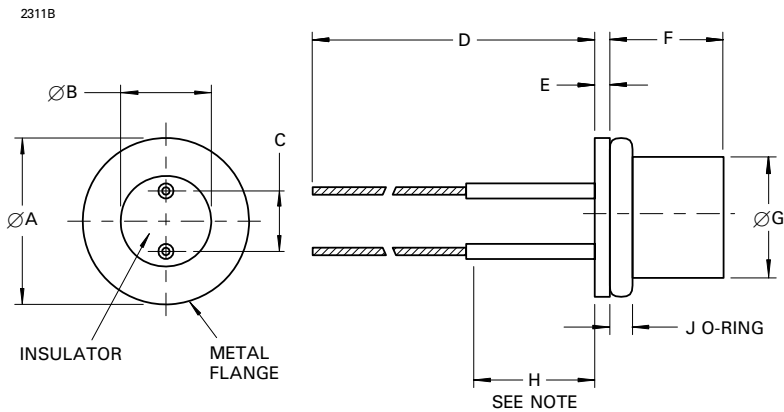

Ref	Millimetres
A	11.05 ± 0.25
B	6.10 ± 0.25
C	3.56 ± 0.13
D	63.50 min
E	1.02
F	7.37 ± 0.51
G	8.20 max
H	9.53
J	1.52

Note No bends may be made in this length.

RECOMMENDED MOUNTING ARRANGEMENTS

2310C

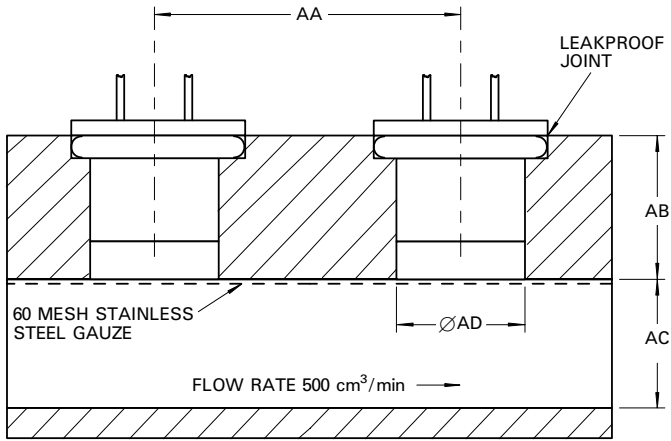

Ref	Millimetres
AA	19.05 max
AB	9.53 ± 0.13
AC	8.33 ± 0.13
AD	8.20 min
AE	19.05 max
AF	9.53 ± 0.13
AG	8.20 min

