

HOUSING  
SEE NOTE 7

NOTE 5

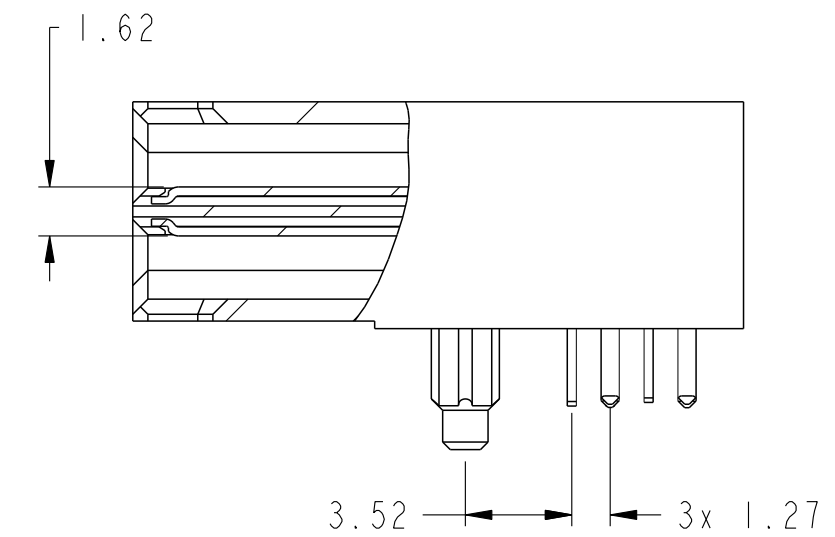
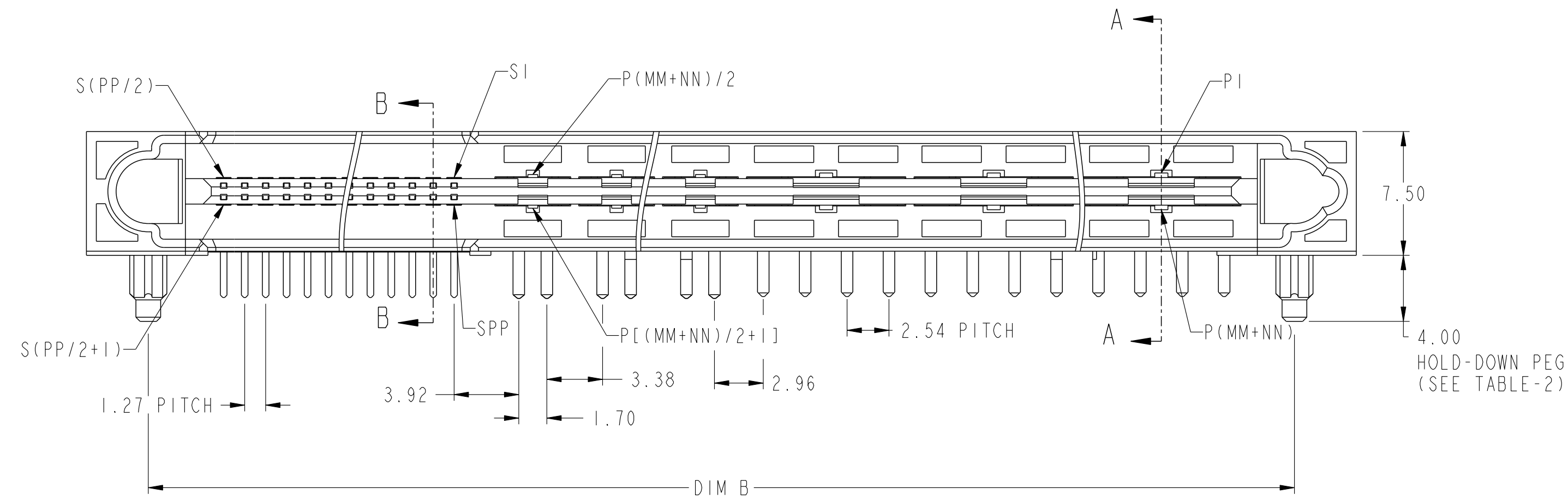

SECTION B-B  
SCALE 4:1

4.00  
HOLD-DOWN PEG  
(SEE TABLE-2)

spec ref	dr	Hai-Ling Liu	2015/03/30	projection	MM	size	A2	scale	1:1
tolerance std	eng	Hai-Ling Liu	2015/05/11			ecn no	-	rel level	Released
TOLERANCES UNLESS OTHERWISE SPECIFIED	chr	Terris Liu	2015/05/11						
	appr	Pei-Ming Zheng	2015/05/11						
surface	linear	0.X	±0.5			title HPCE BTB RAH UNIVERSAL DRAWING	dwg no 10134214	rev A	
		0.XX	±0.25	www.fci.com	cat. no.				Product - Customer Drw
	angular	0°	±2°	PDS: Rev :A		STATUS:Released		Printed: May 12, 2015	



Copyright FCI.

CONTACT TYPE	TOP LAYER DESCRIPTION	TABLE 1 (HPCE / SOLDER TAILS) PLATED THROUGH-HOLE REQUIREMENTS				
		DRILLED HOLE DIAMETER	COPPER THICKNESS	TIN-LEAD THICKNESS	TIN THICKNESS	FINISHED HOLE DIAMETER
POWER	TIN-LEAD	1.10-1.16 (1.15 DRILL)	0.025 - 0.050	0.005 - 0.015	--	0.94 - 1.10
	IMMERSION TIN	1.10-1.16 (1.15 DRILL)	0.025 - 0.050	--	0.9 - 1.5um	0.94 - 1.10
	COPPER (SEE NOTE 8)	1.10-1.16 (1.15 DRILL)	0.025 - 0.050	--	--	0.94 - 1.10
SIGNAL	TIN-LEAD	0.93-0.99 (0.98 DRILL)	0.025 - 0.050	0.005 - 0.015	--	0.77 - 0.93
	IMMERSION TIN	0.93-0.99 (0.98 DRILL)	0.025 - 0.050	--	0.9 - 1.5um	0.77 - 0.93
	COPPER (SEE NOTE 8)	0.93-0.99 (0.98 DRILL)	0.025 - 0.050	--	--	0.77 - 0.93

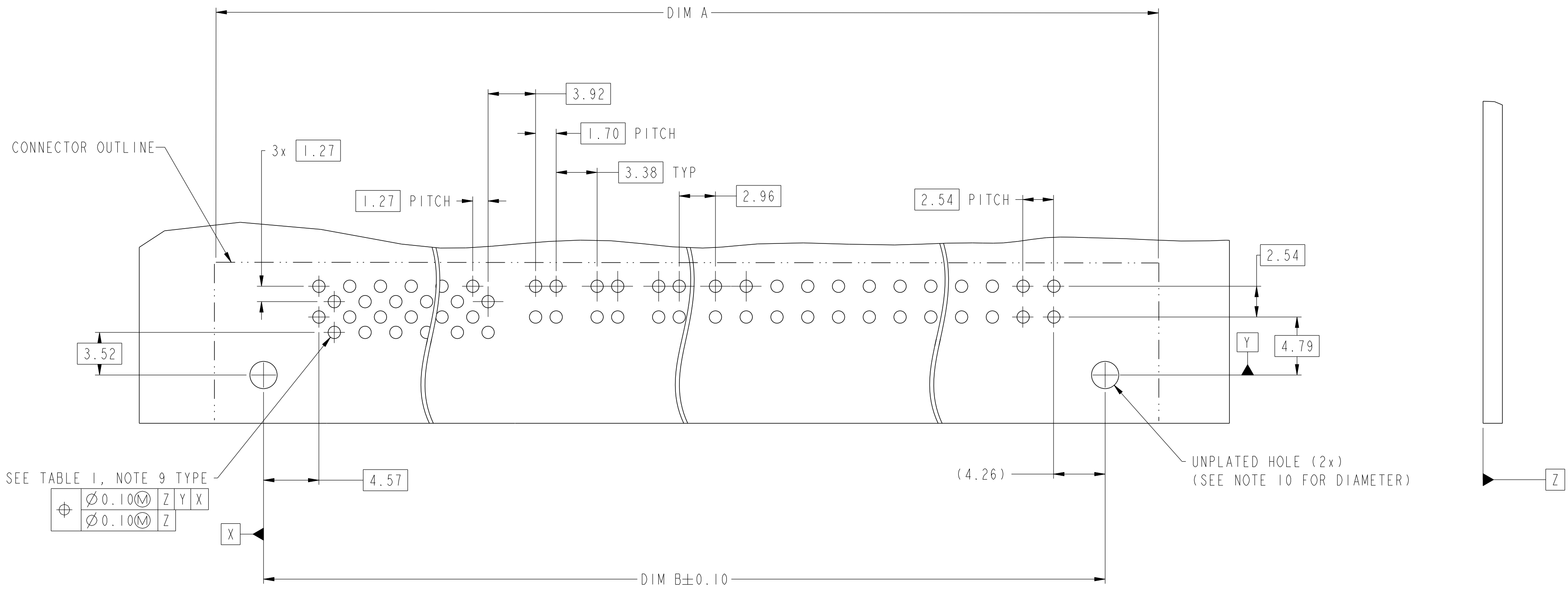

SEE TABLE 1, NOTE 9 TYPE

⊕	∅0.10(M)	Z	Y	X
⊕	∅0.10(M)	Z		

TOP SURFACE  
RECOMMENDED PCB LAYOUT

dr	Hai-Ling Liu	2015/03/30	projection	MM	size	A2	scale	1:1
eng	Hai-Ling Liu	2015/05/11			ecn no	-	rel level	Released
chr	Terris Liu	2015/05/11						
appr	Pei-Ming Zheng	2015/05/11	product family	-	cat. no.	-	Product - Customer Drw	sheet 2 of 3
			title HPCE BTB RAH UNIVERSAL DRAWING			dwg no 10134214		rev A

Copyright FCI.

10134214 - MM NN PP

LF  
LEAD FREE

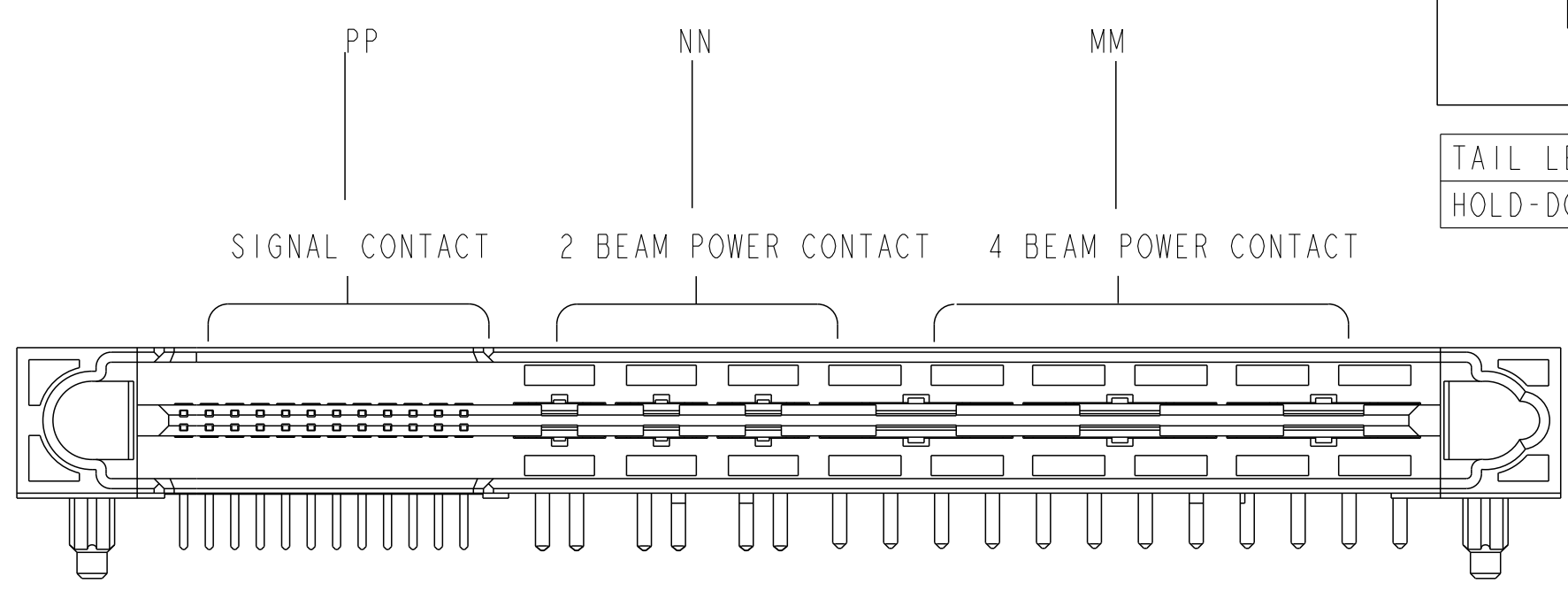

	A	B	C	D
TAIL LENGTH(DIM T)	2.60		3.25	
HOLD-DOWN PEGS OPTION	Y	N	Y	N

DIM	TABLE 2. LENGTH FORMULAS
DIM A II	$(MM + NN) / 2 \times 2.54 + (PP / 2) \times 1.27 + 16.02$
DIM B	$DIM A - 7.5$
DIM T	2.60 OR 3.25

Example: The configuration above is 10134214-241224CLF  
 STD HPCE BTB R/A HEADER 36P24S with Hold-Down Pegs.  
 24P is 4 beam contact, 12P is 2 beam contact.

TABLE 3: PART NUMBER CODE. HPCE BTB R/A HEADER P+S CONFIG

NOTES:

- CONNECTOR MATERIALS:  
 HOUSING: HIGH TEMPERATURE THERMAL PLASTIC, BLACK UL 94V-0 COMPLIANT  
 CONTACTS: HIGH PERFORMANCE COPPER ALLOY.
- CONTACT FINISH REF. GS-12-1031 SECTION TBD
- PRODUCT SPECIFICATION: GS-12-1125
- APPLICATION SPECIFICATION: GS-20-0388
- PRODUCT MARKING (FCI PART NUMBER & DATE CODE) ON HOUSING IN AREA SHOWN.
- PACKAGING MEETS FCI SPECIFICATION GS-14-2272.
- HOUSING COMPONENT WILL WITHSTAND EXPOSURE TO 260°C PEAK TEMPERATURE FOR 60 SECONDS IN A CONVECTION, INFRA-RED, OR VAPOR PHASE REFLOW OVEN.
- COPPER PLATING THICKNESS IN CENTER OF VIA-HOLE CAN BE NO MORE THAN 0.003 LESS THAN OTHER AREAS.
- ALL HOLE SIZES ARE FINISHED HOLE SIZES.
- MOUNTING HOLES ARE UNPLATED  
 $\varnothing 2.20 \pm 0.05$  FOR SOLDER TAILS
- MAXIMUM OVERALL LENGTH IS 100 mm

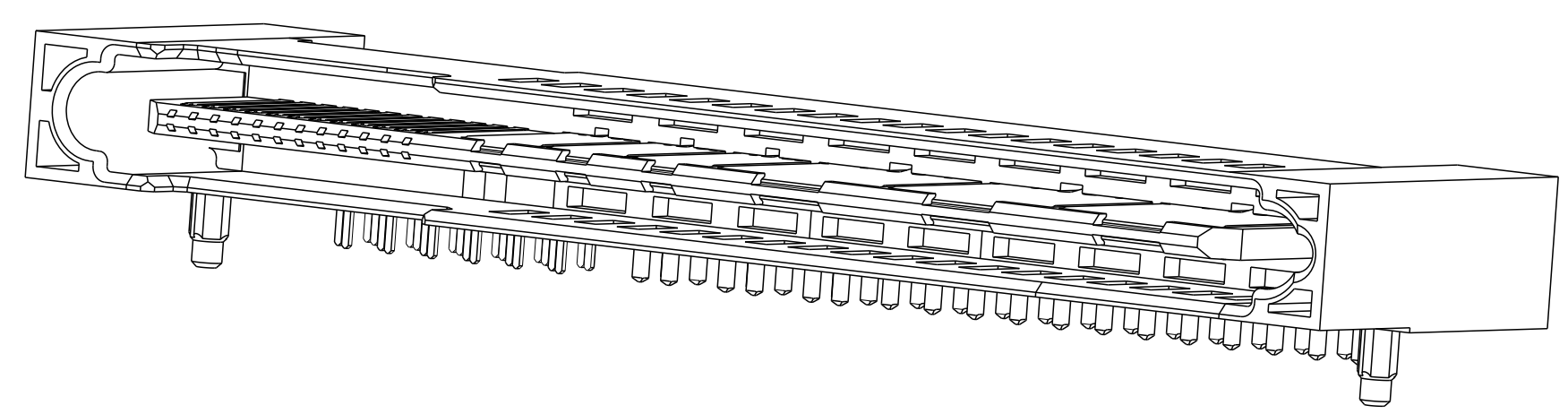

Copyright FCI. FCI

dr	Hai-Ling Liu	2015/03/30	projection	MM	size	A2	scale	1:1
eng	Hai-Ling Liu	2015/05/11			ecn no	-	rel level	Released
chr	Terris Liu	2015/05/11						
appr	Pei-Ming Zheng	2015/05/11	product family	-	cat. no.	-	Product - Customer Drw	sheet 3 of 3
			title HPCE BTB RAH UNIVERSAL DRAWING		dwg no 10134214		rev A	