

BRDS

BRD S 100 -

① ② ③ ④ ⑤

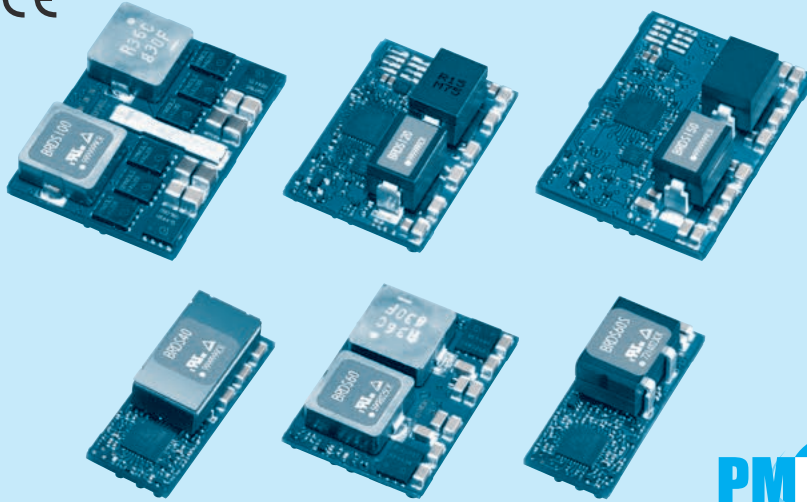

- ① Series name
- ② Single output
- ③ Output current
40:40A
60:60A
100:100A
120:120A
150:150A
- ④ Type
Blank: Standard type
S: Small type (Only 60A)
- ⑤ Optional
R: Positive logic remote on/off

MODEL	BRDS40	BRDS60	BRDS60S	BRDS100	BRDS120	BRDS150
MAX OUTPUT CURRENT[A]	40.0	60.0	60.0	100.0	120.0	150.0
DC OUTPUT	0.6 - 2.0V	0.7 - 2.0V	0.6 - 2.0V	0.7 - 2.0V	0.6 - 1.8V	0.6 - 1.8V *6

SPECIFICATIONS

	MODEL	BRDS40	BRDS60	BRDS60S	BRDS100	BRDS120	BRDS150
INPUT	VOLTAGE[V]	DC4.5 - 14.0					
	CURRENT[A]	*1 4.52 typ	6.82 typ	6.71 typ	11.24 typ	13.50 typ	16.90 typ
	EFFICIENCY[%]	*1 88.5 typ	88.0 typ	89.5 typ	89.0 typ	89.0 typ	89.0 typ
OUTPUT	VOLTAGE[V]	*2 0.6 - 2.0	0.7 - 2.0	0.6 - 2.0	0.7 - 2.0	0.6 - 1.8	0.6 - 1.8 *6
	CURRENT[A]	40	60	60	100	120	150
	LINE REGULATION[mV]	5					
	LOAD REGULATION[mV]	5					
	RIPPLE[mVp-p]	*3 25					
	RIPPLE NOISE[mVp-p]	*3 50					
	OUTPUT VOLTAGE SETTING [%Vo]	±1					
	DRIFT[mV]	*4 5					
	START-UP TIME[ms]	12.0 typ					
	OUTPUT VOLTAGE ADJUSTMENT RANGE [V]	Adjustable by external resistor					
	0.6 - 2.0	0.7 - 2.0	0.6 - 2.0	0.7 - 2.0	0.6 - 1.8	0.6 - 1.8 *6	
	OUTPUT VOLTAGE TOTAL REGULATION [%Vo]*5 ±3						
PROTECTION CIRCUIT AND OTHERS	OVERCURRENT PROTECTION	Works over 105% of rating (auto recovery type)					
	REMOTE SENSING	Available					
	REMOTE ON/OFF	Available Negative logic L:ON, H:OFF					
ISOLATION	INPUT-OUTPUT	non-isolated					
ENVIRONMENT	OPERATING TEMP., HUMID. AND ALTITUDE	-40 to +85°C, 20-95%RH (Non condensing) (Refer to DERATING CURVE) 3,000m (10,000feet) max					
	STORAGE TEMP., HUMID. AND ALTITUDE	-40 to +100°C, 20-95%RH (Non condensing), 9,000m (30,000feet) max					
	VIBRATION	10-55Hz, 49.0m/s ² (5G), 3minutes period, 60minutes each along X, Y and Z axis					
	IMPACT	196.1m/s ² (20G), 11ms, once each along X, Y and Z axis					
SAFETY	AGENCY APPROVALS	UL60950-1, C-UL (CSA60950-1), EN60950-1					
OTHERS	CASE SIZE/WEIGHT	33.0×10.9×13.5mm [1.3×0.43×0.53 inches] (W×H×D) / 12g max	33.0×8.0×22.9mm [1.3×0.31×0.9 inches] (W×H×D) / 15g max	33.0×12.7×13.5mm [1.3×0.5×0.53 inches] (W×H×D) / 12g max	38.0×8.5×27.7mm [1.5×0.33×1.09 inches] (W×H×D) / 22g max	33.0×12.7×22.9mm [1.3×0.5×0.9 inches] (W×H×D) / 14g max	38.0×13.8×27.7mm [1.5×0.54×1.09 inches] (W×H×D) / 21g max
	COOLING METHOD	Convection / Forced air					

*1 At rated input (DC12V) and rated output (1.2V) Ta=25°C.
 *2 Output voltage is adjusted to the minimum when TRM is opened.
 *3 Ripple and ripple noise is measured by using measuring board with ceramic capacitor at 50mm from output pin.
 *4 Drift is the change in DC output for an eight hour period after a half - hour warm - up at 25°C, with the input voltage held.
 *5 Output voltage setting is added line regulation and load regulation and temperature regulation used resistance of the 0.5% tolerance.
 *6 The output voltage adjustment area determines by the input voltage.
 * This product is subject to a license from PAI Capital LLC related to digital power technology patents owned by PAI Capital LLC.

External view

1. BRDS40

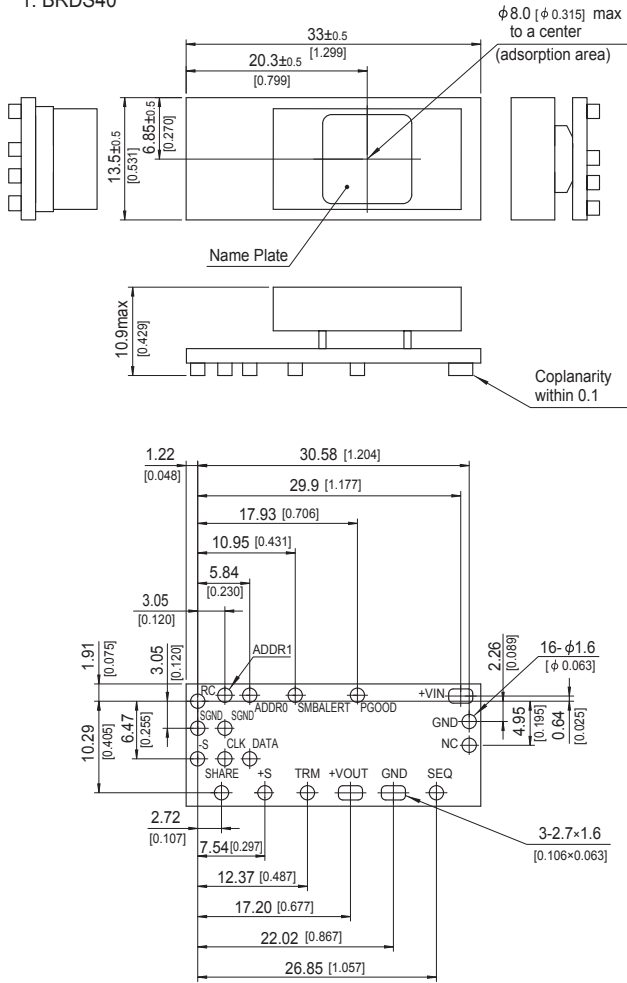

- ※ Tolerance : ± 0.3 [± 0.012]
- ※ Dimensions in mm, []=inches
- ※ Weight : 12g max
- ※ Terminal material : copper
- ※ Plating treatment of terminal : Lead free plating

2. BRDS60S

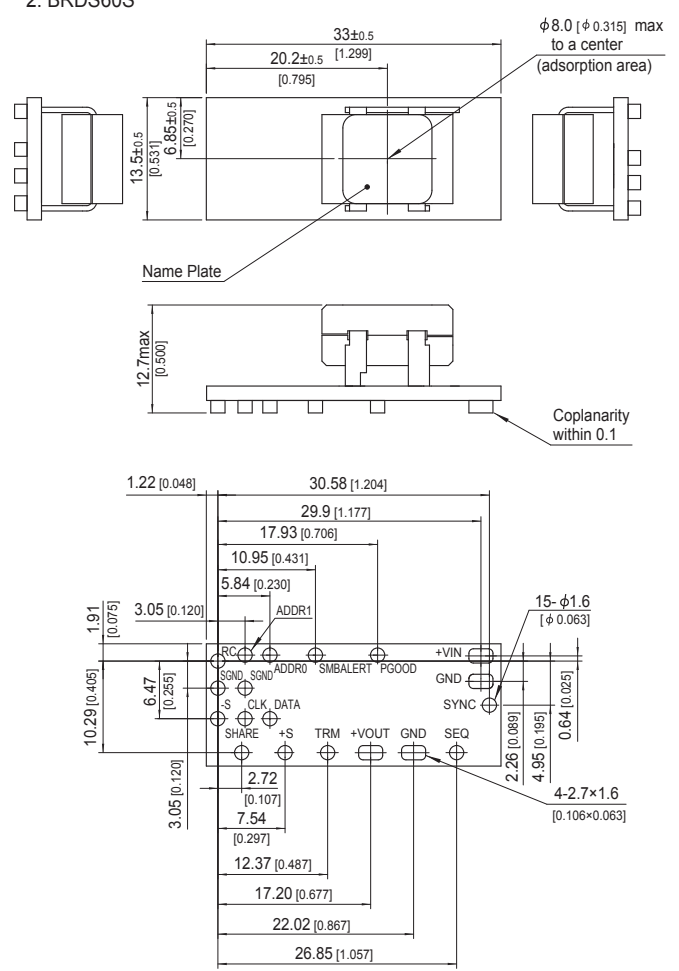

- ※ Tolerance : ± 0.3 [± 0.012]
- ※ Dimensions in mm, []=inches
- ※ Weight : 12g max
- ※ Terminal material : copper
- ※ Plating treatment of terminal : Lead free plating

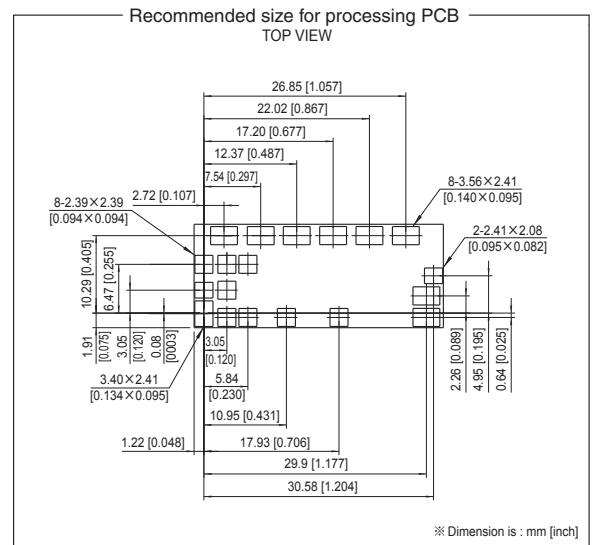
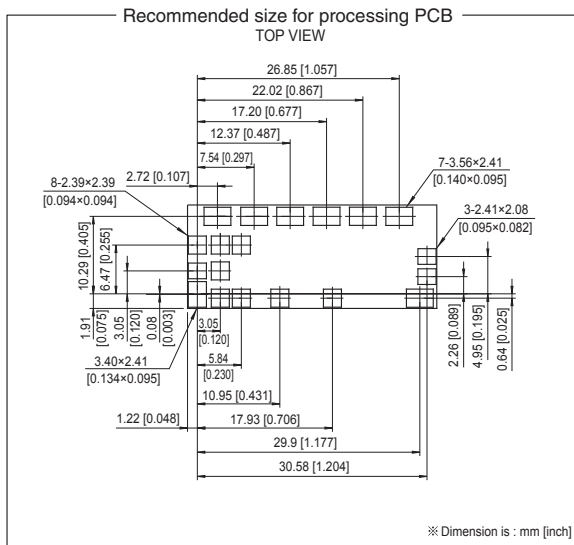

External view

3. BRDS60

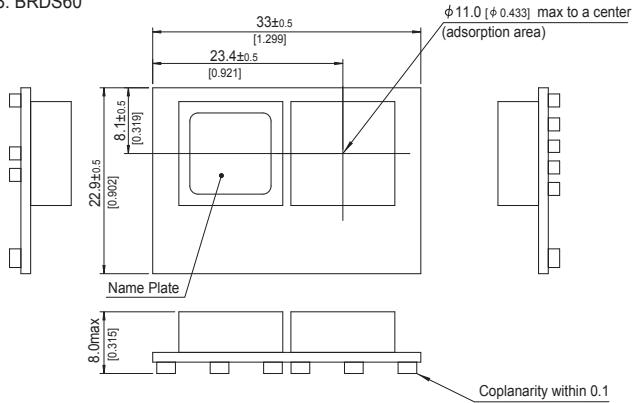

4. BRDS100

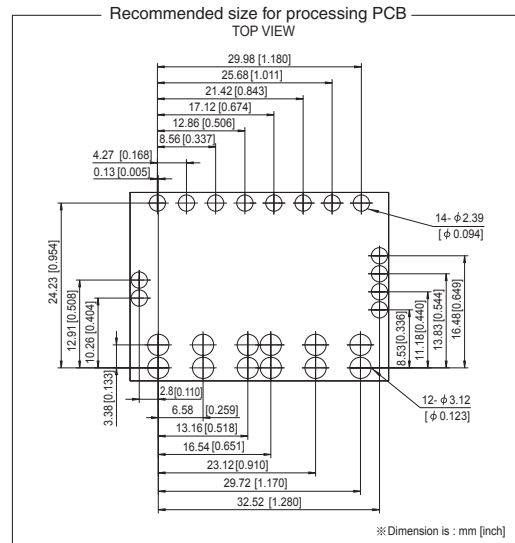
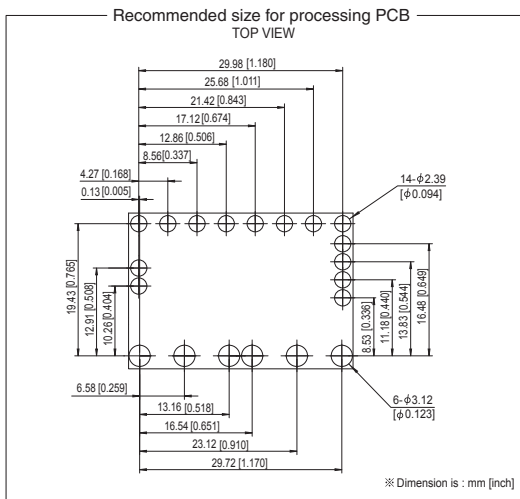
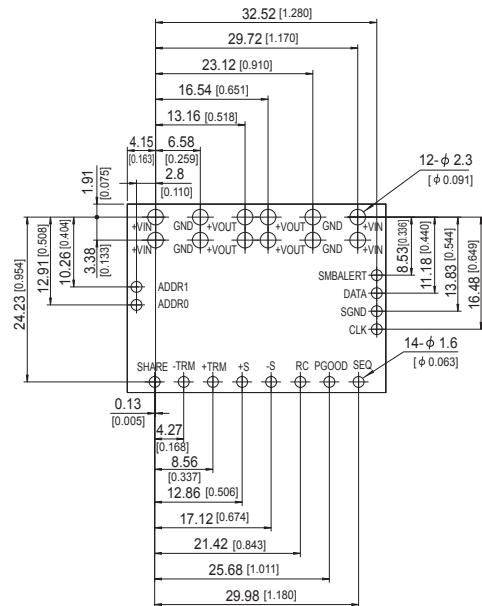
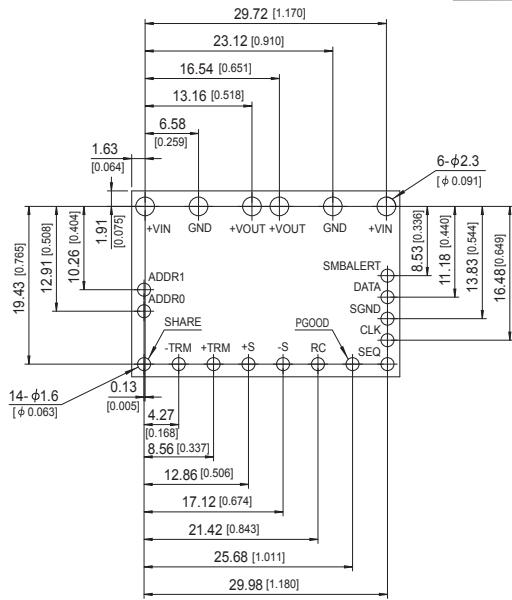
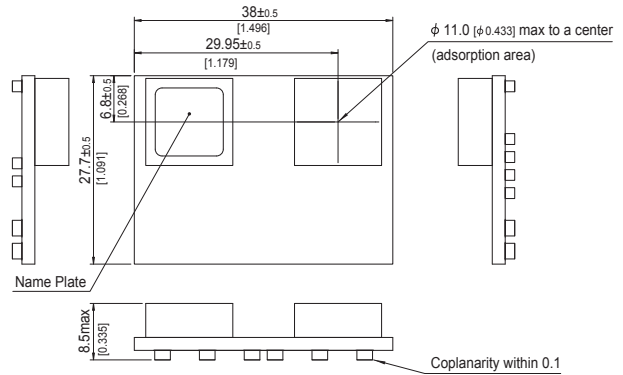

- ※ Tolerance : ±0.3 [±0.012]
- ※ Dimensions in mm, []=inches
- ※ Weight : 15g max
- ※ Terminal material : copper
- ※ Plating treatment of terminal : Lead free plating

- ※ Tolerance : ±0.3 [±0.012]
- ※ Dimensions in mm, []=inches
- ※ Weight : 22g max
- ※ Terminal material : copper
- ※ Plating treatment of terminal : Lead free plating

External view

5. BRDS120

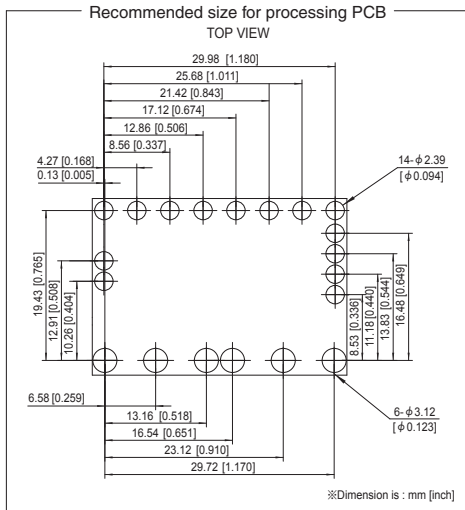
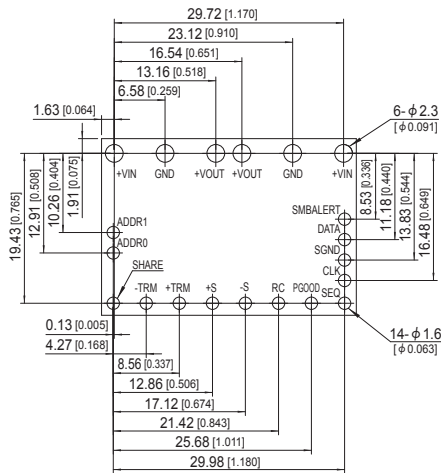
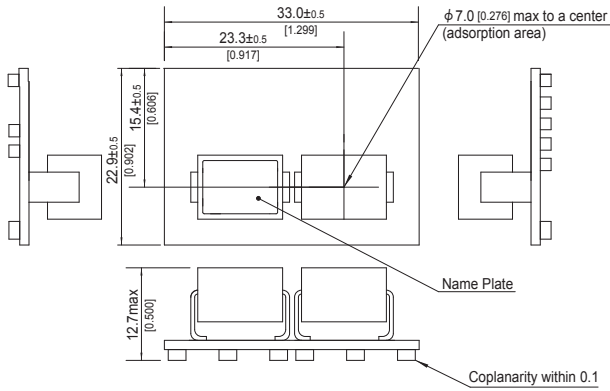

- * Tolerance : ± 0.3 [± 0.012]
- * Dimensions in mm, [] =inches
- * Weight : 14g max
- * Terminal material : copper
- * Plating treatment of terminal : Lead free plating

6. BRDS150

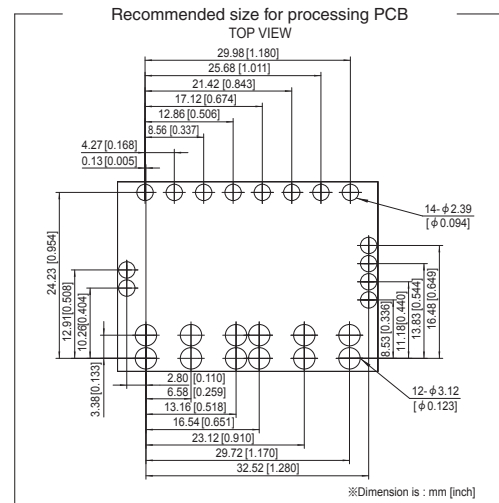
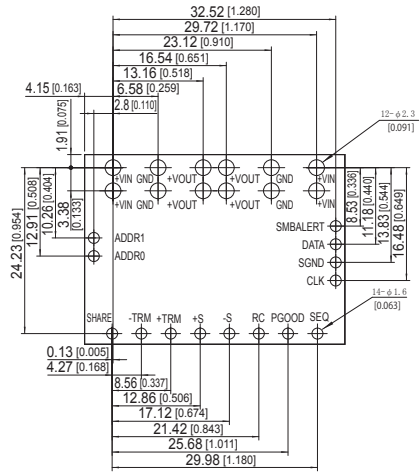
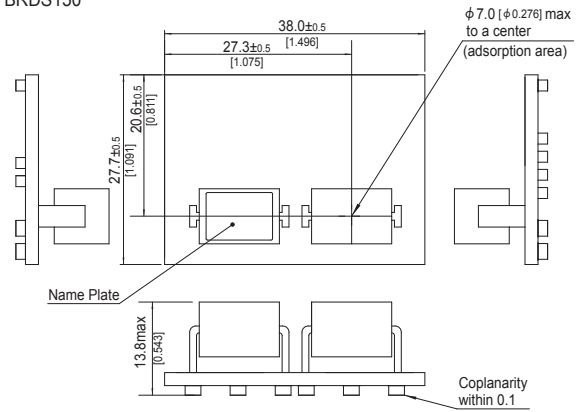

- * Tolerance : ± 0.3 [± 0.012]
- * Dimensions in mm, [] =inches
- * Weight : 21g max
- * Terminal material : copper
- * Plating treatment of terminal : Lead free plating

Mouser Electronics

Authorized Distributor

Click to View Pricing, Inventory, Delivery & Lifecycle Information:

Cosel:

[BRDS60S](#) [BRDS120](#) [BRDS150](#)