

Smart Power Monitor KM50-C1-FLK

CSM_KM50-C1-FLK_DS_E_1_2

• Low Cost Power Monitor for On-panel Mounting and Display

• Assists Energy-saving Analysis

- Power and current can be measured simultaneously.
- Measurement of flow rates with a pulse conversion function.
- Simple temperature measurements with Temperature Sensor included in the Unit.

• High-precision Measurements

- Measurement of generated power (regenerative power), leading reactive power, lagging reactive power, and consumed power.
- Power measurements on the primary side of inverters, which are widely used to save energy.
- Automatic range switching for accurate measurement of standby and stopped power.

• Energy-saving Functions

- Conversion to monetary cost.
- Alarm outputs can be selected for active power, reactive power, regenerative power, current, voltage, or power factor.
- The Power Monitor can log measurement data and supports Modbus communications.

• Installation and Settings

- Simple measurements without voltage wiring.
- Incorrect voltage wiring detection.



For the most recent information on models that have been certified for safety standards, refer to your OMRON website.

Note: Not valid for billing applications.

Refer to "Safety Precautions" on page 9.

Features

■ Functions That Support Energy-saving Analysis

● Pulse Measurement and Conversion

1. Flow rates can be measured at the same time as power by inputting flow pulses. (Two inputs are supported.)
To support energy-saving analysis, power consumption can be compared with the flow rate of air, gas, or other fluids with a single Unit.
2. Pulse inputs can be counted, or used to measure the ON time.
The consumption rate of a device can be measured by dividing the power consumption with the measured number of operations or operation time.

Pulse Input Count Measurement

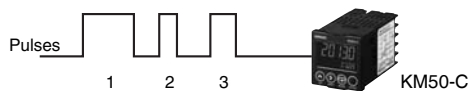

Pulse Input ON Time Measurement

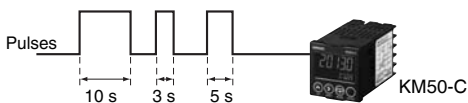

● Simple Temperature Measurement

KM50 Power Monitors have a thermistor chip built onto the panel surface for easy measurement of the panel surface temperature. The temperature display can be offset to match the room temperature to manage trends.

■ Energy Management with High-precision Measurements

● Total Regenerated Energy Measurement

In addition to the consumed energy (total regenerative power consumption), generated power (total regenerative energy) can also be measured.
A single Power Monitor can measure equipment that effectively uses power generated by reverse motor rotation.

● Total Reactive Power Measurement

In addition to instantaneous reactive power, the total leading or lagging power consumption can also be measured.
Together with peak power measurements, this function aids with monitoring the power distribution equipment.

● Automatic Range Switching

Automatic range switching enables high-accuracy measurements even for microcurrents.

Standby and stopped power can be accurately measured.
When measured at the distribution board, the total of the distributed values is almost the same as the base measurement.

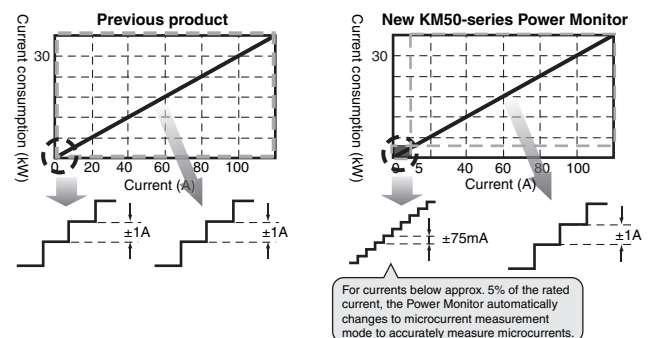

You can measure microcurrents of ± 75 mA with a CT with a rated current of 100 A. (Reference Value)
You can measure microcurrents of ± 4 mA with a CT with a rated current of 5 A. (Reference Value)

Note: Reference values are typical values. Actual values may vary.

● Inverter Compatibility

Measurements can be made on the primary side of an inverter.
Power consumption can be measured even after installing inverters which are widely used to save energy. This enables you to accurately grasp the effect obtained by introducing the inverter.

Functions That Support Saving Energy

● Conversion to Monetary Cost

The total power consumption can be converted to the equivalent monetary cost.

Displaying the cost of the wasted energy can be used to support energy-saving measures.

● Alarm Output

An alarm can be output when active power exceeds a certain limit. There are two outputs; a pulse output and an output for alarm selection.

Alarms can also be set up for generated power (regenerative power), current, voltage, power factor, or reactive power to assist plant monitoring.

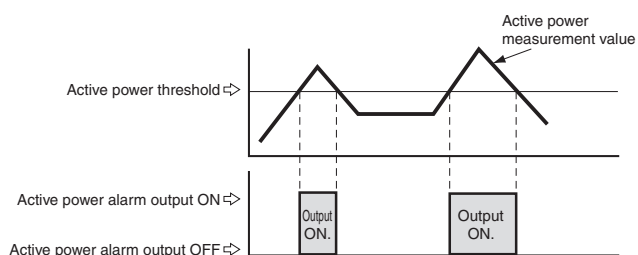

● Built-in Logging Function

The total power consumption can be saved in internal memory every 5 minutes, hour, day, or month.

Data can be saved as follows: 5-minute data for two days, 1-hour data for eight days, 1-day data for month, and 1-month data for one year.

Data Logging Cycle and Amounts

Total power consumption	Every 5 min: 48 hours of data *1
	Every hour: 25 hours of data *2
	Every day: 8 days of data
	Every month: 13 months of data
Active power, current, voltage, and maximum/minimum power factors	Every day: 8 days of data

*1 The data that is logged with a 5-minute cycle can be read out only by using RS-485 communications.

Readout is not possible with key operations on the Power Monitor.

*2 Up to 48 hours of data can be read out using communications.

Ordering Information

KM50-C Smart Power Monitor

Model	Applicable circuits	Power supply voltage	Dimensions	Communications	Protocol
KM50-C1-FLK	Single-phase, 2-wire: 100 to 240 VAC Single-phase, 3-wire: 100/200 VAC Three-phase, 3-wire: 100 to 240 VAC	Shared with measurement voltage input 100 to 240 VAC	48 × 48 × 84 (H × W × D)	RS-485	CompoWay/F: 31 nodes, Modbus: 99 nodes (Both are supported by the same model.)

CTs

These CTs must be used with the KM50/KM20-B40/-FLK. Do not use them with any other products.

Model	Rated primary current	Rated secondary current	Installation
KM20-CTF-5A	5 A	Special output	Installed separately
KM20-CTF-50A	50 A		
KM20-CTF-100A	100 A		
KM20-CTF-200A	200 A		
KM20-CTF-400A	400 A		
KM20-CTF-600A	600 A		

Note: CT Cables are not included with the CTs.

CT Cable

Model	Cable length
KM20-CTF-CB3	3 m

Note: Either use the CT Cable specified by OMRON or use 1.25-B3A crimp terminals and AWG22 wire from J.S.T. Mfg. Co., Ltd.

Functions That Support Installation and Settings

● Simple Measurement

- The simple measurement function calculates the power from a fixed voltage and the measured current using a fixed power factor.
- This function can be used when the voltage cannot be input to the KM50 due to onsite conditions or wiring arrangements.
- If the Simple Measurement parameter is set to ON, the fixed voltage and fixed power factor can be set.
- The simple measurement function can be used to get an approximate power consumption of an installed circuit without wiring and measuring the voltage. Therefore, you must set the voltage and power factors to appropriate levels.
- Fixed values are used for the voltage and power factor, so the accuracy specifications do not apply.

* Set the voltage to 100 V when performing simple measurements on a single-phase, three-wire power supply.

● Incorrect Wiring Detection

Incorrect voltage wiring can be detected.

If any mistakes were made during installation, they are automatically detected, reducing the time required for checking after installation. This also reduces the risk of having to restart when a mistake is found.

● Communications

Up to 99 KM50 Power Monitors can be connected using RS-485 Modbus. The energy use of each device can be managed with minimal wiring.

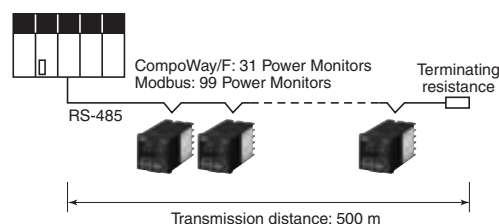

Mounting Brackets (for DIN Track or Magnet Mounting)

Model	Specification
KM50-OPT-ED1 *	DIN Track mounting
KM50-OPT-EM1 *	Magnet mounting
KM50-OPT-CD1	DIN Track mounting

* You can mount one KM50-E or two KM50-C Power Monitors.

Specifications

Ratings

Item	Model	KM50-C
Applicable circuit		Single-phase two-wire, single-phase three-wire, and three-phase three-wire power
Rated power supply voltage		100 to 240 VAC, 50/60 Hz The power supply voltage and measurement voltage input are shared (terminals 6 and 7).
Allowable supply voltage range		85% to 110% of rated power supply voltage
Allowable frequency range		45 to 65 Hz
Power consumption		7 VA max.
Rated input	Rated input voltage	100 to 240 VAC (single-phase, 2-wire): Line voltage 100/200 VAC (single-phase, 3-wire): Phase voltage/line voltage 100 to 240 VAC (3-phase, 3-wire): Line voltage
	Rated input current	5 A, 50 A, 100 A, 200 A, 400 A, or 600 A (primary current of Special CT) *
	Rated frequency	50/60 Hz
	Rated input power	With 5-A CT: 2 kW With 50-A CT: 20 kW With 100-A CT: 40 kW With 200-A CT: 80 kW With 400-A CT: 160 kW With 600-A CT: 240 kW
	Allowable input voltage	110% of rated input voltage (continuous)
	Allowable input current	120% of rated input current (continuous)
	Rated input load	Voltage input: 0.5 VA max. (excluding power supply) Current input: 0.5 VA max. (for each input)
Time		2010 to 2099 (Adjusted for leap year.) Accuracy: ±1.5 min/month (at 23 °C)
Time backup period		3 days (without power supply, at 23 °C)
Ambient operating temperature		-10 to +55 °C (with no condensation or icing)
Storage temperature		-25 to +65 °C (with no condensation or icing)
Ambient operating humidity		25% to 85%
Storage humidity		25% to 85%
Altitude		2,000 m max.
Installation environment		Overvoltage category and measurement category: 2, Pollution level: 2

* A special output signal is output as the secondary current from the Special CT.

Performance Smart Power Monitor

Item	Model	KM50-C
Accuracy *1	Voltage	±1.0% FS ±1 digit (at ambient temperature of 23 °C, rated input, and rated frequency). However, the accuracy is ±2.0% FS ±1 digit for the Vtr line voltage for three-phase, three-wire power and the Vrs line voltage for single-phase, three-wire power under the same conditions.
	Current	±1.0% FS ±1 digit (at ambient temperature of 23 °C, rated input, and rated frequency). However, the accuracy is ±2.0% FS ±1 digit for the phase-S current for three-phase, three-wire power and the phase-N current for single-phase, three-wire power under the same conditions.
	Active power Reactive power	±2.0% FS ±1 digit (at ambient temperature of 23 °C, rated input, rated frequency, and a power factor of 1) Reactive power formula: $\text{Reactive power} = v \times i \times \sin \theta$ * "v" is the instantaneous voltage and "i" is the instantaneous current. θ is the phase difference between the voltage and current.
	Frequency	±0.3 Hz ±1 digit (at ambient temperature of 23 °C, rated input, and rated frequency)
	Power factor	±5.0% FS ±1 digit (at ambient temperature of 23 °C, rated input, rated frequency, and Power factor = 0.5 to 1 to 0.5) Power factor formula: $\text{Power factor} = \text{Active power} / \text{Apparent power}$ * $\text{Apparent power} = \sqrt{(\text{Active power})^2 + (\text{Reactive power})^2}$
	Temperature	±5 °C two hours after the power is turned ON (after setting the offset to match the ambient environment)
Low-cut current set value		0.1% to 19.9% of rated current input (in 0.1% increments)
Sampling cycle		100 ms for measurement voltage at 50 Hz and 83.3 ms for measurement voltage at 60 Hz
Temperature influence *1		±1.0% FS ±1 digit (percentage of power within operating temperature range, at ambient temperature of 23 °C, rated input, rated frequency, and power factor of 1)
Frequency influence *1		±1.0% FS ±1 digit (percentage of power within rated frequency ±5 Hz, at ambient temperature of 23 °C, rated input, and power factor of 1)
Influence of harmonics *1		±0.5% FS ±1 digit (at ambient temperature of 23 °C, error for superimposed 2nd, 3rd, 5th, 7th, 9th, 11th, and 13th harmonics for a content percentage of 30% for current and 5% for voltage of the basic wave)
Insulation resistance		1) Between all current and voltage inputs and all of the RS-485 terminals, OUT1, event inputs, and I/O commons: 20 MΩ max. (at 500 VDC) 2) Between all electric circuits and the front case: 20 MΩ max. (at 500 VDC)
Dielectric strength		1) Between all current and voltage inputs and all of the RS-485 terminals, OUT1, event inputs, and I/O commons: 2,800 VAC for 1 min 2) Between all electric circuits and the front case: 2,800 VAC for 1 min
Vibration resistance		Single amplitude: 0.35 mm, Acceleration: 50 m/s ² , Frequency: 10 to 15 Hz, 10 sweeps for 8 min each along three axes
Shock resistance		150 m/s ² , 3 times each in 6 directions (up/down, left/right, forward/backward)
Weight		Approx. 150 g (Power Monitor only)
Degree of protection		Front panel: IP66 (when mounted to a panel), Rear case: IP20, Terminal section: IP00
Memory backup		EEPROM (non-volatile memory), No. of writes: 1,000,000 times
Compliant standards		EN61010-1 (IEC61010-1), EN61326-1 (IEC61326-1), UL61010-1, CAN/CSA-C22.2 No.61010-1
Event inputs	Number of inputs	Two event inputs The common terminal is shared with the OUT1
	Voltage input	High level: 4.75 to 30 VDC Low level: 0 to 2 VDC Input impedance: Approx. 2 kΩ
	No-voltage input	ON resistance: 1 kΩ max. OFF resistance: 100 kΩ min. ON residual voltage: 8 V max. ON current (at 0 Ω): 10 mA max.
	Minimum input time	5 ms
Transistor outputs	Number of outputs	One open-collector output (one total power consumption pulse output or alarm output) The common terminal is shared with the event inputs.
	Output capacity	30 VDC, 30 mA max. ON residual voltage: 12 V max. OFF leakage current: 100 μA max.
	Alarm output delay *2	OFF delay: 0.0 to 99.9 s, ON delay: 0.0 to 99.9 s
	Characteristic operating time *3	±200 ms
Communications	Communications method	RS-485 (2-wire half-duplex)
	Sync method	Start-stop
	Unit number setting	CompoWay/F: 0 to 99, Modbus: 1 to 99
	Baud rate	1.2, 2.4, 4.8, 9.6, 19.2, 38.4 kbps
	Transmission code	CompoWay/F: ASCII, Modbus: Binary
	Data length	7, 8 bits
	Stop bit length	1, 2 bits
	Vertical parity	Even, odd, or none
	Maximum transmission distance	500 m
Maximum number of connected Power Monitors	CompoWay/F: 31, Modbus: 99	

Item	Model	KM50-C	
EMC (Industrial electromagnetic environment)	EMI EN61326-1	Radiated RF Electromagnetic Field: CISPR 11 class A Conducted Emission: CISPR 11 class A	
	EMS EN61326-1	Electrostatic Discharge Immunity : EN61000-4-2 Electromagnetic Field Immunity : EN61000-4-3 Fast Transient/Burst Noise Immunity : EN61000-4-4 Surge Immunity : EN61000-4-5 Conducted Disturbance Immunity : EN61000-4-6 Power Frequency Magnetic Field Immunity : EN61000-4-8 Voltage Dip and Interruption Immunity : EN61000-4-11	

*1 The error of the Special CT is not included.

*2 There may be error in the alarm output OFF delay and ON delay due to the measurement sampling cycle.

*3 This is the error in the operating time of the alarm output (including the error in the alarm output ON/OFF delays and output terminal switch operating time).

CTs

Item	Model	KM20-CTF-5A	KM20-CTF-50A	KM20-CTF-100A	KM20-CTF-200A	KM20-CTF-400A	KM20-CTF-600A
Rated primary current		5 A	50 A	100 A	200 A	400 A	600 A
Secondary winding		3,000 turns				6,000 turns	9,000 turns
Application frequency		10 Hz to 5 kHz					
Insulation resistance		Between output terminal and external case: 50 MΩ min. (at 500 VDC)					
Dielectric strength		Between output terminal and external case: 2,000 VAC for 1 min					
Protective element		7.5 V clamp element					
Allowable number of connections/disconnections		100 times					
Inner diameter		7.9 dia. max.	9.5 dia. max.	14.5 dia. max.	24.0 dia. max.	35.5 dia. max.	
Operating temperature and humidity range		-20 to +60 °C 85% (with no condensation)					
Storage temperature and humidity range		-30 to +65 °C 85% (with no condensation)					

* If you use a flat cable, select the cable based on the dimensions of the CT.

CT Cable

Model	KM20-CTF-CB3
Cable length	3 m

Note: Either use the CT Cable specified by OMRON or use 1.25-B3A crimp terminals and AWG22 wire from J.S.T. Mfg. Co., Ltd.

Part Names and Functions

KM50-C

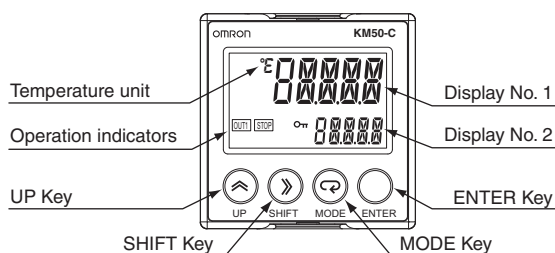

Display Functions

1) Display No. 1

The measured value or set data is displayed here.

2) Display No. 2

The unit of the measured or set data, or the parameter name is displayed here.

3) Operation Indicators

- **OUT1**: Turns ON according to output that is set for terminal OUT1.
- **STOP**: Lights if the power supply is turned ON when the backup power supply for the time data has expired while power was interrupted. The time measurement function will be stopped in this state. This indicator will turn OFF when the time data is set. Measurement data cannot be logged while this indicator is lit.
- **OT** (key indicator): Lit while the settings are protected.

4) Temperature unit

If Celsius is set as the temperature unit, °C will be displayed. If Fahrenheit is set, °F will be displayed.

Connection Diagrams, Terminal Arrangement, and Communications Connections

Connection Diagrams

Smart Power Monitor

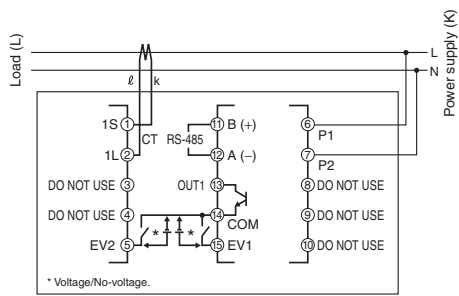

Single-phase, Two-wire Connections

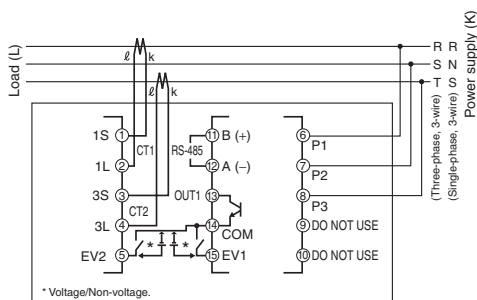

Single-phase, Three-wire or Three-phase, Three-wire Connections

- Note:**
1. Do not ground the Special CTs. Failure may occur.
 2. Use only the Special CTs. Failure may occur.

Terminal Arrangement

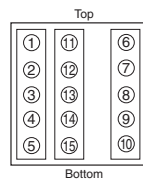

Terminal No.	Terminal name	Terminal No.	Terminal name	Terminal No.	Terminal name
1	CT1S	11	RS-485 B (+)	6	P1 voltage
2	CT1L	12	RS-485 A (-)	7	P2 voltage
3	CT3S	13	OUT1	8	P3 voltage
4	CT3L	14	I/O common	9	DO NOT USE
5	Event input 2	15	Event input 1	10	DO NOT USE

* To use the Power Monitor in Simple Measurement Mode, apply a voltage of 100 VAC between terminals 6 and 7.

Communications Connections Diagram

- To avoid the influence of noise, route the RS-485 communications cable separately from the power lines.
- Use wires with a thickness of AWG24 (0.205 mm²) to AWG14 (2.081 mm²). (The stripping length is 5 to 6 mm.)
- Do not ground the RS-485 communications cable. Doing so may result in malfunction.
- Connect terminating resistance (120 Ω (1/2 W)) to the positive and negative RS-485 lines at the host device and the last device (normally the KM50). To connect terminating resistance to the host device, check the product instructions for the host device.

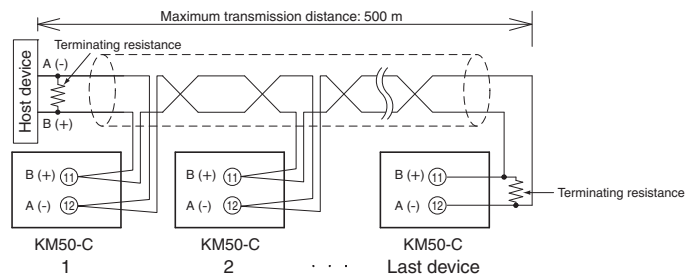

CT Connection Diagram

- One Special CT is required to measure single-phase, two-wire power. Two Special CTs are required to measure single-phase, three-wire power or three-phase, three-wire power.
- All the Special CTs connected to one KM50-C Power Monitor must have the same ratings.
- Make sure that the ratings of the Special CTs and the Special CT setting in the KM50-C Power Monitor are the same.
- Check the directions of the power supply (K) and load (L) before making the connections. Correct measurements will not be possible if they are connected in the wrong directions.
- Release the locking hook and clamp the Special CT on the line. Do this for each phase. Then, press the hook firmly until you hear it lock into place.
- Make sure that the terminal cover on the secondary side of the CT is closed securely.

- The CT does not have polarity. Correctly wire the K terminal on the CT to the 1S or 3S terminal on the KM50-C and wire with L terminal on the CT to the 1L or 3L terminal on the KM50-C.
- Use the KM20-CTF-CB3 CT Cable (3 m) for the CT. Connect the end with shrinking tubes to the CT.
- Do not ground the CT. Doing so may result in malfunction.
- Always use a covered wire with basic insulation of at least 600 V for the primary wire on which the CT is clamped. If you clamp it to a bus bar or other conductive part, cover it with an insulating material or otherwise ensure the minimum basic insulation.

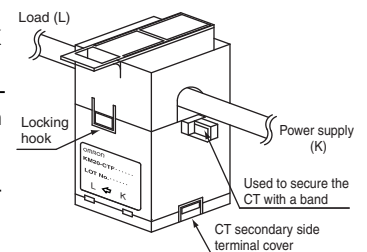

Main Functions

Total Power Consumption Pulse Output

To use total power consumption pulse outputs, connect terminals 13 and 14 (the terminals that were set in the output terminal settings).

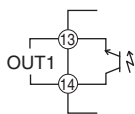

The pulse output cycle can be found with the following formula.

$$\text{Pulse output cycle [s]} = 3,600 \text{ [s]} / \text{Power [W]} / \text{Pulse output unit [W}\cdot\text{h]}$$

Example:

If the input power is 200 [kW] and the pulse output unit is set to 10 k [W•h] for a three-phase, three-wire circuit, the output pulse cycle will be $3,600 \text{ [s]} / 200 \text{ k [W]} / 10 \text{ k [W}\cdot\text{h]} = 180 \text{ [s]}$. If an input power of 10 k [W] continues for one hour (3,600 s), the total power consumption will be 10 k [W•h].

If the input power is 200 k [W] and the pulse output unit is set to 10 k [W•h], 200 k [W]/10 k [W], or 20 pulses will be output. The cycle will therefore be $3,600 \text{ [s]} / 20 \text{ pulses}$, or 180 [s].

As shown in the following figure, one pulse will be output (i.e., the terminal signal will turn ON) every 180 seconds.

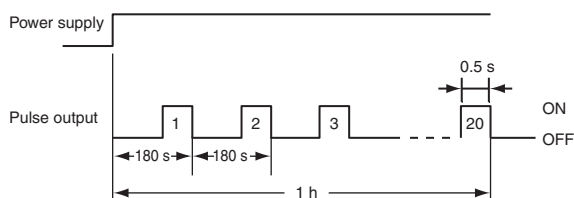

If the cycle becomes shorter than the pulse width or if the output must turn ON immediately after turning OFF, an OFF time of 100 ms will be maintained.

If the OFF time is too short, the PLC or other host may not be able to count the pulses correctly due to the program scan time. Be sure to set a suitable pulse output unit.

Alarm Outputs

To use alarm outputs, connect terminals 13 and 14 (the terminals that were set in the output terminal settings).

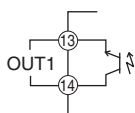

The alarm turns ON if the measured value exceeds the upper limit threshold or falls below the lower limit threshold for the alarm.

If the alarm output is ON, it will remain ON until the measurement value goes below or above the hysteresis range.

The OFF delay, which holds the output ON for a set time after the alarm criteria turns OFF, and the ON delay, which holds the output OFF for a set time after the alarm criteria turns ON, can also be set. When there is an alarm, the OUT 1 operation indicator will light, and the present measurement value will alternate with an alarm output display.

However, the error display is given priority if an E-S1 to E-S4 error occurs.

- Note: 1.** Alarms are output when the threshold and hysteresis criteria is met, and the time set for the OFF delay or ON delay has passed.
- 2.** If the upper limit threshold of the alarm is set to the maximum value, the upper limit alarm function will be disabled. If the lower limit threshold is set to the minimum value, the lower limit alarm function will be disabled.

Event Inputs

To use event inputs, connect terminals 14 and 15 and terminals 5 and 14.

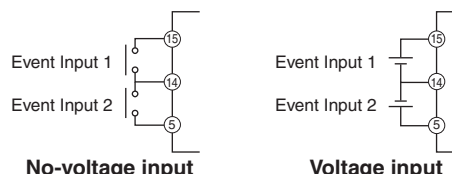

No-voltage input

Voltage input

The ON and OFF criteria may be based on the total count of the two inputs, or an OR of the two inputs.

Input count: Used for the specific power consumption.

OR: The pulse input ON time is measured.

The inputs can be set separately to normally open or normally closed. The start and stop times for measurement can also be set.

The following values can be measured using the event inputs.

- **Specific Power Consumption**
The power consumption calculation function counts the number of times that the event inputs turn ON and calculate the amount of power consumption per count. The total of the number of ON signals of event input 1 and event input 2 is used as the input.
- **Pulse Input ON Time Measurement**
The total time that one or both of the event inputs are ON is calculated for one day and displayed. The ON time is measured for an OR of the event input 1 and event input 2 signals.

Either of the following input modes can be set.

- **Normally Open**
The event input will be considered valid when it is ON and invalid when it is OFF.
- **Normally Closed**
The event input will be considered invalid when it is ON and valid when it is OFF.

A time chart for a normally open setting is shown below.

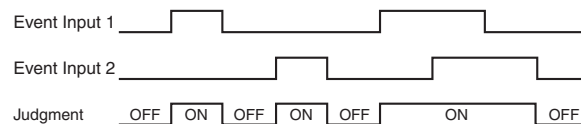

A time chart for a normally closed setting is shown below.

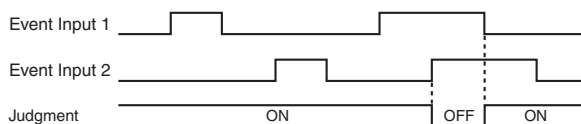

Measurement Log

Measurement logs can be checked.

Total power consumption (for the past 13 months, 8 days, or 25 hours), active power, current, voltage, power factor (maximum and minimum for the past 8 days), reactive power (maximum and minimum of the day), pulse input count, power consumption rate, pulse input ON time (for the last 8 days).

Low-cut Function

When the current is less than the low-cut value (0.1% to 19.9% of the rating), this function forces the current measurement to zero.

This way, current (power) generated due to induced noise in a no-load state can be eliminated.

Low currents are detected using an AND on the phases connected to the CTs.

* Related parameter: *04.CUT*

Simple Measurements

If voltage cannot be input due to site conditions, a user-specified voltage and power factor can be set to determine the approximate power level.

- * Fixed values are used for the voltage and power factor, so the accuracy specifications do not apply.
- * The frequency cannot be measured. It is fixed at 50 Hz.
- * Related parameter: **08.5MP**

Calculated CO₂

The measured power can be converted to CO₂ and displayed. The conversion coefficient depends on the region. Check on the web site of the power company for the applicable coefficient.

- * Related parameter: **10.CO2**

Conversion to Monetary Value

The measured power can be converted to the monetary cost and displayed.

- * Set the conversion factor according to the currency.
- * The user-set currency can be displayed on display No. 2.
- * Related parameter: **11.CHG**

Pulse Conversion

The measured pulse input count can be displayed as a pulse converted value.

- * Set a conversion coefficient according to what you want to display as the pulse converted value.
- * Any user-set unit can be displayed on display No. 2.
- * Related parameter: **12.CV 1, 13.CV 2**

Specific Power Consumption Management

The takt power of the production line can be measured in kW•h/pulse. If the number of manufactured items is input to the Power Monitor as event input pulses, the takt power consumption can be calculated from the total power consumption and displayed for the specified period (1 day maximum).

- * Related parameter: **30.EC5, 31.PN 1, 32.PN2, 33.CN 1, 34.CN2, 35.5tC, 36.6tC**

Wiring Precautions

- Wire signal lines and power lines separately to prevent the influences of noise.
- Use twisted-pair cables with wires of AWG24 to AWG14 (cross-sectional areas of 0.205 to 2.081 mm²). (Use a stripping length of 5 to 6 mm.)
- Use the Special CT Cable (KM20-CTF-CB3, 3 m) to connect Special CTs.
- Connect the Special CT to the end with the shrinking tubes.
- Do not ground the Special CTs or the RS-485 signal line. Failure may occur.
- Use crimp terminals to wire the terminals.
- Use wires and crimping tools that are suitable for the crimp terminals.
- If more than one crimp terminal is connected to the same terminal, it may not be possible to tighten the screw sufficiently. To connect more than one wire to the same terminal, connect all of the wires to one crimp terminal.

Total Regenerative and Reactive Power

The total regenerative power, leading reactive power, lagging reactive power, and accumulative reactive power can be calculated.

- * Total reactive power: the sum of the absolute values of leading and lagging reactive powers.
- * One item out of the four can be logged every five minutes.
- * Related parameter: **60.L5L**

Automatic Rotation

This function automatically changes the measurement mode parameters.

- * The interval at which the parameters change can be set.
- * Related parameter: **61.RLE**

Measurement Parameter Display Selection

The display of each measurement parameter can be set ON or OFF.

- * Related parameter: **62.d5L**

Energy-saving Mode

The display is turned OFF whenever there is no key operation.

- * The time it takes until the display is turned OFF can be specified.
- * Related parameter: **63.d5P**

Incorrect Voltage Wiring Detection

Incorrect voltage input wiring is detected.

If the wiring is not correct, "E-54" is displayed.

- * Related parameter: **64.V-E**

Simple Temperature Measurements

Temperature measurement is simplified.

- * Celsius or Fahrenheit can be selected.
- * Related parameter: **65.d-U**

- Tightening the terminal screws to a torque of 0.69 and 0.88 N•m.
- Use the following shape of M3.5 crimp terminals.

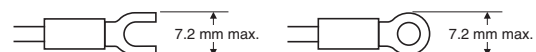

- Do not remove the terminal blocks. Doing so may cause failure or malfunction.
- To extend the distance between a CT and the Unit, we recommend that you combine a commercial CT and a Special CT.

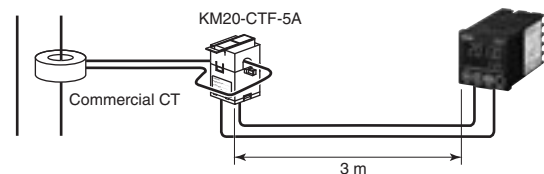

Safety Precautions

 CAUTION	Indicates a potentially hazardous situation which, if not avoided, may result in minor or moderate injury, or property damage.
---	--

 CAUTION
--

Fire or property damage may occasionally occur.
Tighten terminal screws to the specified tightening torque.
The recommended tightening torque is 0.69 to 0.88 N·m.
Confirm that the screws are straight (i.e., not at an angle) after tightening them.



Minor or moderate bodily harm or property damage may occasionally occur due to explosion.
Do not use the product near inflammable or explosive gas.



Destruction or rupture may occasionally occur.
Make sure that the power supply voltage is within specifications.



Destruction or rupture may occasionally occur.
The voltage input circuit and CT secondary circuit are not isolated. If a Special CT is grounded, incorrect wiring will short circuit the voltage input and the secondary circuit of the CT. To prevent failure, do not ground a Special CT.
The Power Monitor uses a Special CT. Correct measurements can be made even if the CT is not grounded.



Electrical shock may occasionally occur.
Always turn OFF the power supply before connecting CTs.



Electrical shock may occasionally occur.
Do not touch any of the terminals while the power is being supplied.



Electrical shock may occasionally occur.
The voltage input circuit and CT secondary circuit are not isolated.
Do not touch the secondary side of the Special CT.



Electrical shock, minor injury, fire, or equipment malfunction may occasionally occur.
Do not attempt to disassemble, modify, or repair the product.



Precautions for Safe Use

1. Do not store, install, or use the product in the following locations.
 - Locations that are greatly affected by vibration or shock
 - Unstable locations
 - Outdoors or locations that are subject to direct sunlight, wind, or rain
 - Locations where the specified range of temperature or humidity would be exceeded
 - Locations that are subject to rapid changes in temperature or humidity where condensation or icing may occur
 - Locations that are affected by static electricity or noise
 - Locations that are subject to corrosive gas (particularly sulfide or ammonia gas)
 - Locations that are excessively dusty or dirty
 - Locations that are subject to flooding or oil
 - Locations that are affected by electric or magnetic fields
 - Locations that are subject to splashing brine
2. Install the product in a panel with a panel thickness of 1 to 8 mm. If a suitable panel thickness is not used or the product is installed incorrectly, the product may come free from the mounting.
3. Do not attempt to pull the internal part of the product out of the case. Pulling out the internal part of the product will increase the contact resistance of the internal terminals, possibly damaging measurement accuracy.
4. Read and understand the Operation Manual before attempting to install, use, or maintain the product. Electrical shock, injury, accidents, failure, or malfunction may occur.
5. Always check the wiring and confirm that it is correct before turning ON the power supply. Incorrect or improper wiring may result in electrical shock, injury, accidents, failure, or malfunction.
6. Use power supplies and wires with suitable specifications for the control power supply and the power supply for inputs and other parts of the system. Failure, burning, or electrical shock may result.
7. Do not install the product near sources of heat, such as devices with coils or windings.
8. Check all terminal numbers before wiring.
9. Do not connect anything to unused terminals.
10. Use crimp terminals that are suitable for M3.5 screws to wire the product.
11. Install the product well separated from devices with strong high-frequency noise (such as high-frequency welders or sewing machines) or devices that generate surge.
12. To prevent inductive noise, wire the lines connected to the product separately from power lines carrying high voltages or currents. Do not wire in parallel with or on the same cable as power lines. Other measures for reducing noise include running lines along separate ducts and using shields.
13. Do not touch conductive metal parts on the product or the CT terminals while power is being supplied.
14. Do not use the product for measurement on the secondary side of an inverter.
15. Do not block the ventilation holes in or the areas around the product to ensure proper dissipation of heat.
16. Touch grounded metal to discharge any static electricity before touching the product.
17. Do not remove the terminal blocks from the product. Doing so may cause failure or malfunction.
18. Do not continue to use the product if the front surface peels or becomes cracked. Water may enter the product.
19. Install and suitably label a switch or circuit breaker that complies with relevant requirements of IEC 60947-1 and IEC 60947-3 so that the operator can immediately turn OFF the power supply.
20. When using the product in an Overvoltage Category 3 environment, externally install varistors between the power supply and voltage measurement inputs to the product.
21. Use only the Special CT and Special CT Cable specified by OMRON. Special CTs: KM20-CTF-5A, KM20-CTF-50A, KM20-CTF-100A, KM20-CTF-200A, KM20-CTF-400A, or KM20-CTF-600A
Special CT Cable: KM20-CTF-CB3 (3 m)
22. The Power Monitor is a Class A product (for use in industrial environments). In residential environment areas it may cause radio interference. If it causes radio interference, the user may be required to take adequate measures to reduce interference.

Precautions for Correct Use

1. Make sure that all parameters are set suitably for the measurement target.
2. This product is not a Special Measuring Instrument that has passed testing by a specified body under the Measurement Act of Japan. It cannot be used to certify power consumption under Japanese law.
3. Do not use solvents, such as paint thinners, to clean the product. Use commercially available alcohol instead.
4. Make sure the rated voltage is reached within 2 s after the power is turned ON. Otherwise, the product may not operate correctly.
5. When discarding the product, properly dispose of it as industrial waste according to all applicable local ordinances.
6. If a water-proof structure is required, install the enclosed Waterproof Packing. Depending on the application environment, the Waterproof Packing can deteriorate, shrink, or harden. We recommend that you replace it periodically. Waterproof Packing: Y92S-29 (sold separately)
7. Remove the protective film from the front of the product before using the product.
8. Wire the middle row (terminals 11 to 15) last. Refer to "Terminal Arrangement" on page 6.
9. Reception interference may occur if the KM50 is installed near radios, televisions, or other wireless devices.

Dimensions

Smart Power Monitor

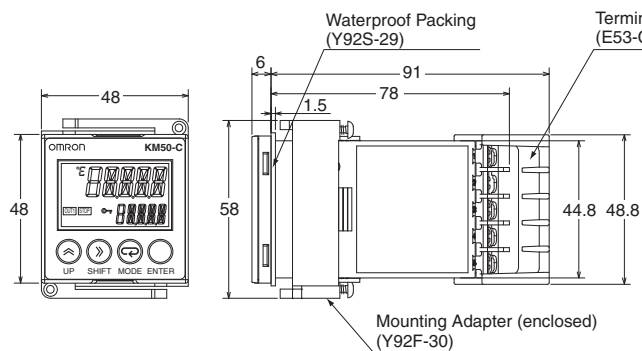

Panel Mounting Dimensions

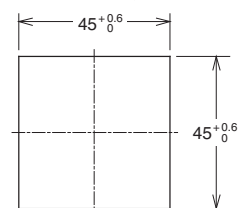

- Use M3.5 crimp terminals.
- The mounting panel must be 1 to 5mm thick.
- When mounting KM50-C Power Monitors side by side, provide sufficient space between them.
- Reference separation: 60 mm (top, bottom, left, and right)
- Make sure that the rated ambient temperature of the KM50-C Power Monitor is not exceeded when more than one Power Monitor is mounted.

CTs

KM20-CTF-5A

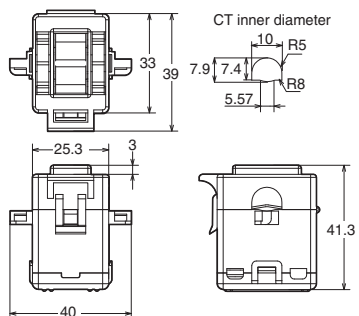

KM20-CTF-50A

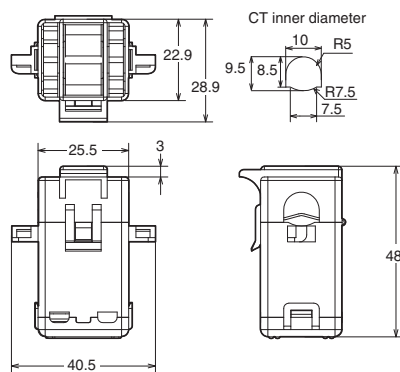

KM20-CTF-100A

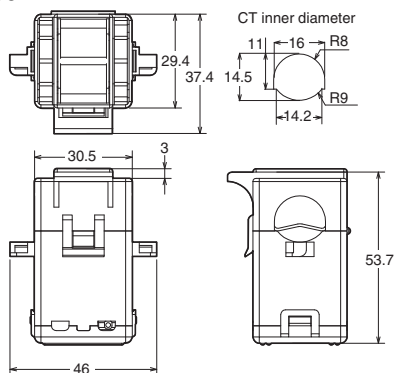

KM20-CTF-200A

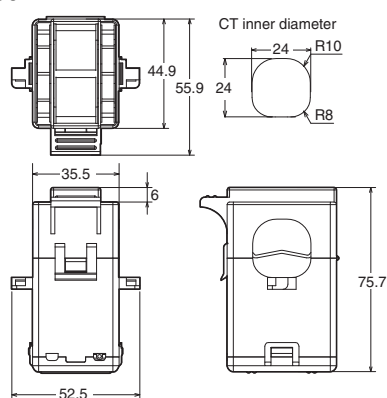

KM20-CTF-400A/600A

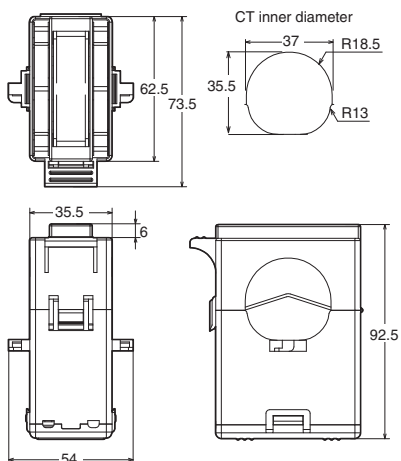

KM20-CTF-CB3 (Special CT Cable)

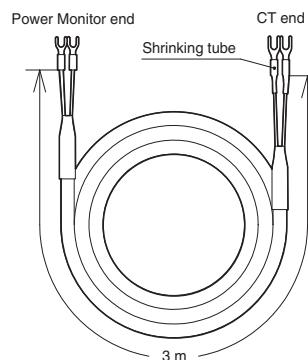

Special CTs and CT Cable

- Use only the CTs and CT Cable specified by OMRON.
- If any other CTs or CT Cables are used, normal measurements will not be possible.
- The Special CTs have polarity.
Connect the Special CT correctly, connecting the 1S or 3S terminal on the Power Monitor to the k terminal on the CT and the 1L or 3L terminal on the Power Monitor to the I terminal on the CT.
- Do not ground the Special CTs. Failure may occur.

Special CTs for the KM20-B40 and KM20-B40-FLK

Rated primary current of 5 A: KM20-CTF-5A

Rated primary current of 50 A: KM20-CTF-50A

Rated primary current of 100 A: KM20-CTF-100A

Rated primary current of 200 A: KM20-CTF-200A

Rated primary current of 400 A: KM20-CTF-400A

Rated primary current of 600 A: KM20-CTF-600A

KM20-CTF-series CT Cable

KM20-CTF-CB3 (3 m)

Optional Accessories

Mounting Bracket Dimensions

KM50-OPT-ED1

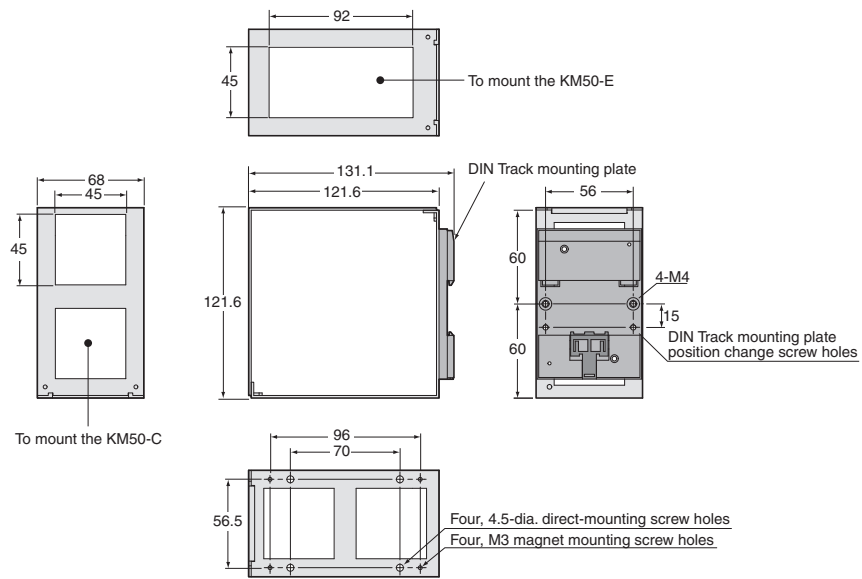

KM50-OPT-EM1

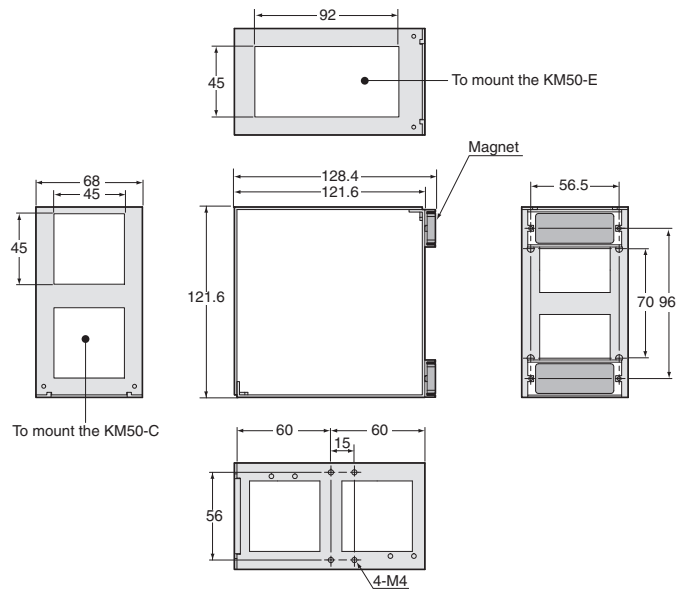

KM50-OPT-CD1

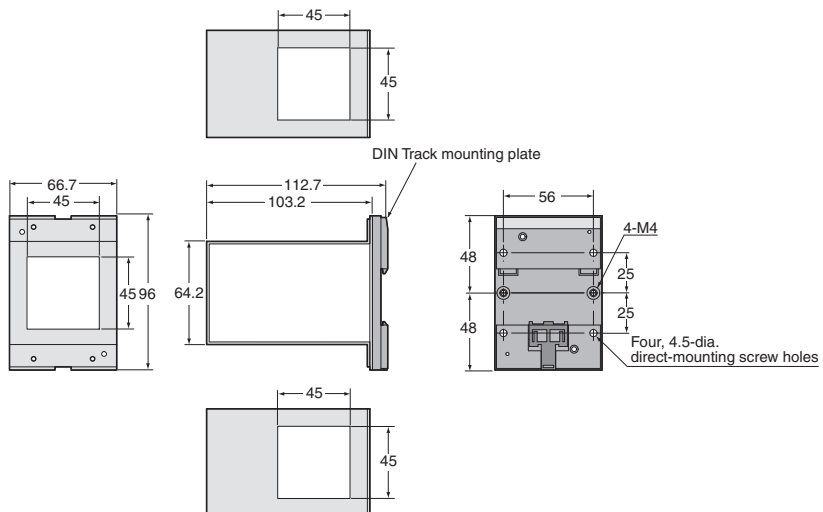

Terms and Conditions Agreement

Read and understand this catalog.

Please read and understand this catalog before purchasing the products. Please consult your OMRON representative if you have any questions or comments.

Warranties.

(a) Exclusive Warranty. Omron's exclusive warranty is that the Products will be free from defects in materials and workmanship for a period of twelve months from the date of sale by Omron (or such other period expressed in writing by Omron). Omron disclaims all other warranties, express or implied.

(b) Limitations. OMRON MAKES NO WARRANTY OR REPRESENTATION, EXPRESS OR IMPLIED, ABOUT NON-INFRINGEMENT, MERCHANTABILITY OR FITNESS FOR A PARTICULAR PURPOSE OF THE PRODUCTS. BUYER ACKNOWLEDGES THAT IT ALONE HAS DETERMINED THAT THE PRODUCTS WILL SUITABLY MEET THE REQUIREMENTS OF THEIR INTENDED USE.

Omron further disclaims all warranties and responsibility of any type for claims or expenses based on infringement by the Products or otherwise of any intellectual property right. (c) Buyer Remedy. Omron's sole obligation hereunder shall be, at Omron's election, to (i) replace (in the form originally shipped with Buyer responsible for labor charges for removal or replacement thereof) the non-complying Product, (ii) repair the non-complying Product, or (iii) repay or credit Buyer an amount equal to the purchase price of the non-complying Product; provided that in no event shall Omron be responsible for warranty, repair, indemnity or any other claims or expenses regarding the Products unless Omron's analysis confirms that the Products were properly handled, stored, installed and maintained and not subject to contamination, abuse, misuse or inappropriate modification. Return of any Products by Buyer must be approved in writing by Omron before shipment. Omron Companies shall not be liable for the suitability or unsuitability or the results from the use of Products in combination with any electrical or electronic components, circuits, system assemblies or any other materials or substances or environments. Any advice, recommendations or information given orally or in writing, are not to be construed as an amendment or addition to the above warranty.

See <http://www.omron.com/global/> or contact your Omron representative for published information.

Limitation on Liability; Etc.

OMRON COMPANIES SHALL NOT BE LIABLE FOR SPECIAL, INDIRECT, INCIDENTAL, OR CONSEQUENTIAL DAMAGES, LOSS OF PROFITS OR PRODUCTION OR COMMERCIAL LOSS IN ANY WAY CONNECTED WITH THE PRODUCTS, WHETHER SUCH CLAIM IS BASED IN CONTRACT, WARRANTY, NEGLIGENCE OR STRICT LIABILITY.

Further, in no event shall liability of Omron Companies exceed the individual price of the Product on which liability is asserted.

Suitability of Use.

Omron Companies shall not be responsible for conformity with any standards, codes or regulations which apply to the combination of the Product in the Buyer's application or use of the Product. At Buyer's request, Omron will provide applicable third party certification documents identifying ratings and limitations of use which apply to the Product. This information by itself is not sufficient for a complete determination of the suitability of the Product in combination with the end product, machine, system, or other application or use. Buyer shall be solely responsible for determining appropriateness of the particular Product with respect to Buyer's application, product or system. Buyer shall take application responsibility in all cases.

NEVER USE THE PRODUCT FOR AN APPLICATION INVOLVING SERIOUS RISK TO LIFE OR PROPERTY OR IN LARGE QUANTITIES WITHOUT ENSURING THAT THE SYSTEM AS A WHOLE HAS BEEN DESIGNED TO ADDRESS THE RISKS, AND THAT THE OMRON PRODUCT(S) IS PROPERLY RATED AND INSTALLED FOR THE INTENDED USE WITHIN THE OVERALL EQUIPMENT OR SYSTEM.

Programmable Products.

Omron Companies shall not be responsible for the user's programming of a programmable Product, or any consequence thereof.

Performance Data.

Data presented in Omron Company websites, catalogs and other materials is provided as a guide for the user in determining suitability and does not constitute a warranty. It may represent the result of Omron's test conditions, and the user must correlate it to actual application requirements. Actual performance is subject to the Omron's Warranty and Limitations of Liability.

Change in Specifications.

Product specifications and accessories may be changed at any time based on improvements and other reasons. It is our practice to change part numbers when published ratings or features are changed, or when significant construction changes are made. However, some specifications of the Product may be changed without any notice. When in doubt, special part numbers may be assigned to fix or establish key specifications for your application. Please consult with your Omron's representative at any time to confirm actual specifications of purchased Product.

Errors and Omissions.

Information presented by Omron Companies has been checked and is believed to be accurate; however, no responsibility is assumed for clerical, typographical or proofreading errors or omissions.

2015.9

In the interest of product improvement, specifications are subject to change without notice.

OMRON Corporation
Industrial Automation Company

<http://www.ia.omron.com/>

(c)Copyright OMRON Corporation 2015 All Right Reserved.

Mouser Electronics

Authorized Distributor

Click to View Pricing, Inventory, Delivery & Lifecycle Information:

[Omron:](#)

[KM50-C1-FLK](#)