

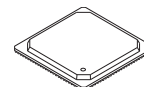

## MPC5121E/MPC5123

### MPC5121E/MPC5123 Data Sheet



516 TEPBGA  
27 mm x 27 mm

The MPC5121e/MPC5123 integrates a high performance e300 CPU core based on the Power Architecture® Technology with a rich set of peripheral functions focused on communications and systems integration.

- On-chip temperature sensor
- IIM – IC Identification module

Major features of the MPC5121e/MPC5123 are:

- e300 Power Architecture processor core
- Power modes include doze, nap, sleep, deep sleep, and hibernate
- AXE – Auxiliary Execution Engine
- MBX Lite – 2D/3D graphics engine (not available in MPC5123)
- DIU – Display interface unit
- DDR1, DDR2, and LPDDR/mobile-DDR SDRAM memory controller
- MEM – 128 KB on-chip SRAM
- USB 2.0 OTG controller with integrated physical layer (PHY)
- DMA subsystem
- EMB – Flexible multi-function external memory bus interface
- NFC – NAND flash controller
- LPC – LocalPlus interface
- 10/100Base Ethernet
- PCI interface, version 2.3
- PATA – Parallel ATA integrated development environment (IDE) controller
- SATA – Serial ATA controller with integrated physical layer (PHY)
- SDHC – MMC/SD/SDIO card host controller
- PSC – Programmable serial controller
- I<sup>2</sup>C – inter-integrated circuit communication interfaces
- S/PDIF – Serial audio interface
- CAN – Controller area network
- BDLC – J1850 interface
- VIU – Video Input, ITU-656 compliant
- RTC – On-Chip real-time clock

# Table of Contents

|        |   |    |        |   |    |
|--------|---|----|--------|---|----|
| 1      | Ordering Information                          | 3  | 3.3.11 | FEC   | 57 |
| 2      | Pin Assignments                               | 5  | 3.3.12 | USB ULPI  | 59 |
| 2.1    | 516-TEPBGA Ball Map                           | 5  | 3.3.13 | On-Chip USB PHY                                 | 60 |
| 2.2    | Pinout Listings                               | 6  | 3.3.14 | SDHC  | 60 |
| 3      | Electrical and Thermal Characteristics        | 17 | 3.3.15 | DIU   | 62 |
| 3.1    | DC Electrical Characteristics                 | 17 | 3.3.16 | SPDIF   | 65 |
| 3.1.1  | Absolute Maximum Ratings                      | 17 | 3.3.17 | CAN   | 65 |
| 3.1.2  | Recommended Operating Conditions              | 18 | 3.3.18 | I <sup>2</sup> C                                | 65 |
| 3.1.3  | DC Electrical Specifications                  | 19 | 3.3.19 | J1850   | 66 |
| 3.1.4  | Electrostatic Discharge                       | 22 | 3.3.20 | PSC   | 66 |
| 3.1.5  | Power Dissipation                             | 23 | 3.3.21 | GPIOs and Timers                                | 73 |
| 3.1.6  | Thermal Characteristics                       | 24 | 3.3.22 | Fusebox   | 73 |
| 3.2    | Oscillator and PLL Electrical Characteristics | 25 | 3.3.23 | IEEE 1149.1 (JTAG)                              | 74 |
| 3.2.1  | System Oscillator Electrical Characteristics  | 26 | 3.3.24 | VIU   | 76 |
| 3.2.2  | RTC Oscillator Electrical Characteristics     | 26 | 4      | System Design Information                       | 76 |
| 3.2.3  | System PLL Electrical Characteristics         | 26 | 4.1    | Power Up/Down Sequencing                        | 76 |
| 3.2.4  | e300 Core PLL Electrical Characteristics      | 27 | 4.2    | System and CPU Core AVDD Power Supply Filtering | 76 |
| 3.3    | AC Electrical Characteristics                 | 28 | 4.3    | Connection Recommendations                      | 77 |
| 3.3.1  | Overview                                      | 28 | 4.4    | Pull-Up/Pull-Down Resistor Requirements         | 78 |
| 3.3.2  | AC Operating Frequency Data                   | 28 | 4.4.1  | Pull-Down Resistor Requirements for TEST pin    | 78 |
| 3.3.3  | Resets  | 29 | 4.4.2  | Pull-Up Requirements for the PCI Control Lines  | 78 |
| 3.3.4  | External Interrupts                           | 32 | 4.5    | JTAG  | 78 |
| 3.3.5  | SDRAM (DDR)                                   | 32 | 4.5.1  | TRST  | 78 |
| 3.3.6  | PCI   | 34 | 4.5.2  | e300 COP/BDM Interface                          | 79 |
| 3.3.7  | LPC   | 36 | 5      | Package Information                             | 82 |
| 3.3.8  | NFC   | 43 | 5.1    | Package Parameters                              | 82 |
| 3.3.9  | PATA  | 45 | 5.2    | Mechanical Dimensions                           | 83 |
| 3.3.10 | SATA PHY                                      | 57 | 6      | Product Documentation                           | 84 |

Figure 1 shows a simplified MPC5121e/MPC5123 block diagram.

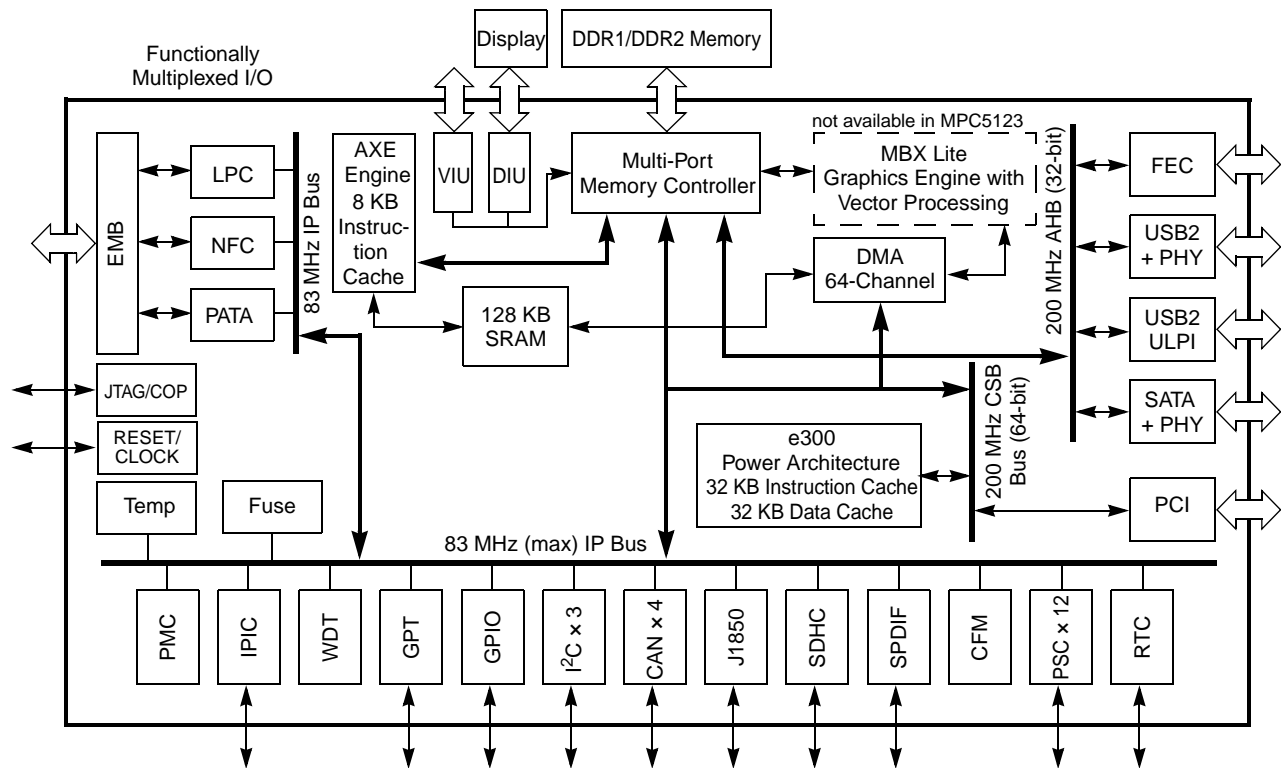

Figure 1. Simplified MPC5121e/MPC5123 Block Diagram

# 1 Ordering Information

Table 1. MPC5121e Orderable Part Numbers

| Freescle Part Number | Speed (MHz) | Temperature (ambient) | Qualification  | Package          | Availability  |
|----------------------|-------------|-----------------------|----------------|------------------|---------------|
| MPC5121VY400B        | 400         | 0 °C to 70 °C         | Consumer       | RoHS and Pb-free | Tray          |
| MPC5121VY400BR       | 400         | 0 °C to 70 °C         | Consumer       | RoHS and Pb-free | Tape and Reel |
| MPC5121YVY400B       | 400         | -40 °C to 85 °C       | Industrial     | RoHS and Pb-free | Tray          |
| MPC5121YVY400BR      | 400         | -40 °C to 85 °C       | Industrial     | RoHS and Pb-free | Tape and Reel |
| SPC5121YVY400B       | 400         | -40 °C to 85 °C       | Automotive—AEC | RoHS and Pb-free | Tray          |
| SPC5121YVY400BR      | 400         | -40 °C to 85 °C       | Automotive—AEC | RoHS and Pb-free | Tape and Reel |

Table 2. MPC5123 Orderable Part Numbers

| Freescle Part Number | Speed (MHz) | Temperature (ambient) | Qualification | Package          | Availability  |
|----------------------|-------------|-----------------------|---------------|------------------|---------------|
| MPC5123VY400B        | 400         | 0 °C to 70 °C         | Consumer      | RoHS and Pb-free | Tray          |
| MPC5123VY400BR       | 400         | 0 °C to 70 °C         | Consumer      | RoHS and Pb-free | Tape and Reel |
| MPC5123YVY400B       | 400         | -40 °C to 85 °C       | Industrial    | RoHS and Pb-free | Tray          |

**Table 2. MPC5123 Orderable Part Numbers (continued)**

| <b>Freescale Part Number</b> | <b>Speed (MHz)</b> | <b>Temperature (ambient)</b> | <b>Qualification</b> | <b>Package</b>   | <b>Availability</b> |
|------------------------------|--------------------|------------------------------|----------------------|------------------|---------------------|
| MPC5123YVY400BR              | 400                | -40 °C to 85 °C              | Industrial           | RoHS and Pb-free | Tape and Reel       |
| SPC5123YVY400B               | 400                | -40 °C to 85 °C              | Automotive—AEC       | RoHS and Pb-free | Tray                |
| SPC5123YVY400BR              | 400                | -40 °C to 85 °C              | Automotive—AEC       | RoHS and Pb-free | Tape and Reel       |

# 2 Pin Assignments

This section details pin assignments.

## 2.1 516-TEPBGA Ball Map

|    | 1             | 2             | 3                | 4             | 5              | 6            | 7      | 8         | 9           | 10        | 11      | 12      | 13        | 14        | 15        | 16      | 17          | 18        | 19             | 20        | 21                  | 22            | 23             | 24         | 25         | 26        |             |
|----|---------------|---------------|------------------|---------------|----------------|--------------|--------|-----------|-------------|-----------|---------|---------|-----------|-----------|-----------|---------|-------------|-----------|----------------|-----------|---------------------|---------------|----------------|------------|------------|-----------|-------------|
| A  |               | VSS           | VSS              | SATA_RXN      | SATA_RXP       | SATA_RX_VSSA | PSC7_4 | PSC7_3    | PSC6_4      | PSC6_2    | PSC6_0  | PSC11_0 | PSC10_2   | PSC10_3   | PSC1_3    | PSC1_1  | PSC0_1      | CAN1_TX   | GPIO2_8        | RTC_XTALO | USB2_DRVVBUS        | USB_DM        | USB_DP         | USB_TPA    | VSS        |           |             |
| B  | VSS           | VSS           | VSS              | SATA_RX_VSSA  | VSS            | PSC8_3       | VSS    | PSC7_0    | PSC6_3      | VDD_I     | PSC11_1 | VSS     | PSC10_1   | PSC2_1    | VDD_I     | PSC0_4  | VSS         | GPIO3_1   | CAN2_RX        | VSS       | USB2_VBUS_PWR_FAULT | VSS           | USB_VSSA_BIAS  | USB_XTALO  | VDD_I      | VSS       |             |
| C  | VSS           | SATA_XTALO    | SATA_XTALI       | VSS           | SATA_VDDA_1P2  | PSC9_0       | PSC8_2 | PSC7_2    | AVDD_FUSEWR | PSC6_1    | PSC11_2 | PSC10_3 | PSC10_0   | PSC2_0    | PSC1_0    | PSC0_3  | PSC_MCLK_IN | GPIO3_0   | CAN1_RX        | RTC_XTALI | USB_VDDA            | USB_VSSA      | VSS            | USB_XTALI  | VSS        | PCL_CLK   |             |
| D  | SATA_VDDA_1P2 | VSS           | SATA_PLL_VSSA    | SATA_VDDA_3P3 | SATA_VDDA_VREG | PSC9_3       | PSC9_1 | PSC8_1    | VDD_I       | VDD_I     | PSC11_4 | VSS     | PSC2_4    | PSC1_4    | VDD_I     | PSC0_0  | VSS         | HIB_MODE  | VBAT_RTC       | USB_VDDA  | USB_VBUS            | USB_VDDA_BIAS | USB_PL_L_PWR3  | VSS        | VSS        | PCL_REQ2  |             |
| E  | SATA_TXN      | SATA_VDDA_1P2 | SATA_PLL_VDDA1P2 | SATA_RESREF   | SATA_NAVIZ     | PSC9_4       | PSC9_2 | PSC8_4    | PSC8_0      | PSC7_1    | PSC11_3 | PSC10_4 | PSC2_2    | PSC1_2    | PSC0_2    | CAN2_TX | GPIO2_9     | VSS       | USB_UID        | USB_VSSA  | USB_VSSA            | USB_R_B       | USB_PL_GND     | PCL_GNT3   | PCL_GNT0   | PCL_REQ1  |             |
| F  | SATA_TXP      | VSS           | VSS              | VSS           | VSS            | VSS          | VSS    | VSS       | VSS         | VSS       | VDD_I   | VDD_I   | VDD_I     | VDD_I     | VSS       | VSS     | VSS         | VSS       | VDD_I          | VDD_I     | PCL_RST_OUT         | VDD_I         | PCL_D30        | VDD_I      | VDD_I      | PCL_A D28 |             |
| G  | SATA_TX_VSSA  | NFC_RE        | NFC_WE           | NFC_WP        | VSS            |              |        |           |             |           |         |         |           |           |           |         |             |           |                |           |                     | PCL_GNT1      | PCL_REQ0       | PCL_A D29  | PCL_A D26  | PCL_C/BE3 |             |
| H  | NFC_RB        | PATA_DACK     | NFC_E0           | NFC_ALE       | NFC_CLE        | VSS          |        |           |             |           |         |         |           |           |           |         |             |           |                |           | VDD_I               | PCL_A D31     | VSS            | PCL_A D24  | VSS        | PCL_A D21 |             |
| J  | PATA_OR       | PATA_OCHR DY  | PATA_I NTRQ      | PATA_DRQ      | VDD_I          |              |        |           |             |           |         |         |           |           |           |         |             |           |                |           |                     |               | PCL_A D27      | PCL_A D25  | PCL_A D23  | PCL_A D20 | PCL_A D18   |
| K  | PATA_CET      | VDD_I         | PATA_I SOLATE    | VDD_I         | PATA_I OW      | VSS          |        |           |             | VDD_C     | VDD_C   | VDD_C   | VDD_C     | VDD_C     | VDD_C     | VDD_C   | VDD_C       | VDD_C     | VDD_C          | VDD_C     | VDD_C               | VSS           | PCL_ID SEL     | PCL_A D22  | PCL_A D19  | PCL_A D17 | PCL_IR DY   |
| L  | EMB_A D03     | EMB_A D02     | EMB_A D01        | EMB_A D00     | PATA_C E2      | VSS          |        |           |             | VDD_C     | VDD_C   | VDD_C   | VDD_C     | VDD_C     | VDD_C     | VDD_C   | VDD_C       | VDD_C     | VDD_C          | VDD_C     | VDD_C               | VSS           | PCL_A D16      | VDD_I      | PCL_C/BE2  | VDD_I     | PCL_D EVSEL |
| M  | EMB_A D06     | VSS           | EMB_A D05        | VSS           | EMB_A D04      |              |        |           |             | VDD_C     | VDD_C   | VDD_C   | VDD_C     | VDD_C     | VDD_C     | VDD_C   | VDD_C       | VDD_C     | VDD_C          | VDD_C     | VDD_C               |               | PCL_T RDY      | PCL_F RAME | PCL_S TOP  | PCL_P ERR | PCL_S ERR   |
| N  | EMB_A D10     | EMB_A D09     | EMB_A D08        | EMB_A D07     | VSS            | VDD_I        |        |           |             | VDD_C     | VDD_C   | VDD_C   | VDD_C     | VDD_C     | VDD_C     | VDD_C   | VDD_C       | VDD_C     | VDD_C          | VDD_C     | VDD_C               | VDD_I         | PCL_P AR       | VSS        | PCL_C/BE1  | VSS       | PCL_A D15   |
| P  | EMB_A D15     | EMB_A D14     | EMB_A D11        | EMB_A D13     | EMB_A D12      | VDD_I        |        |           |             | VDD_C     | VDD_C   | VDD_C   | VDD_C     | VDD_C     | VDD_C     | VDD_C   | VDD_C       | VDD_C     | VDD_C          | VDD_C     | VDD_C               | VDD_I         | PCL_C/BE0      | PCL_A D09  | PCL_A D13  | PCL_A D14 | PCL_A D12   |
| R  | EMB_A D17     | VDD_I         | EMB_A D16        | VDD_I         | EMB_A D19      |              |        |           |             | VDD_C     | VDD_C   | VDD_C   | VDD_C     | VDD_C     | VDD_C     | VDD_C   | VDD_C       | VDD_C     | VDD_C          | VDD_C     | VDD_C               |               | PCL_A D03      | PCL_A D06  | PCL_A D10  | PCL_A D11 | PCL_A D08   |
| T  | EMB_A D22     | EMB_A D18     | EMB_A D20        | EMB_A D21     | EMB_A D23      | VSS          |        |           |             | VDD_C     | VDD_C   | VDD_C   | VDD_C     | VDD_C     | VDD_C     | VDD_C   | VDD_C       | VDD_C     | VDD_C          | VDD_C     | VDD_C               | VSS           | SYS_PL L_AVDD  | VDD_I      | PCL_A D05  | VDD_I     | PCL_A D07   |
| U  | EMB_A D25     | VSS           | EMB_A D24        | VSS           | EMB_A D29      | VSS          |        |           |             | VDD_C     | VDD_C   | VDD_C   | VDD_C     | VDD_C     | VDD_C     | VDD_C   | VDD_C       | VDD_C     | VDD_C          | VDD_C     | VDD_C               | VSS           | SYS_PL L_AVSS  | PCL_I NTA  | PCL_A D00  | PCL_A D02 | PCL_A D04   |
| V  | EMB_A D26     | EMB_A D27     | EMB_A D28        | EMB_A D30     | EMB_A X01      |              |        |           |             |           |         |         |           |           |           |         |             |           |                |           |                     |               | SRESET         | VSS        | SYS_X TALI | VSS       | PCL_A D01   |
| W  | EMB_A D31     | EMB_A X00     | EMB_A X02        | LPC_A X03     | LPC_C S0       | VDD_I        |        |           |             |           |         |         |           |           |           |         |             |           |                |           |                     | VDD_I         | TDO            | PORES ET   | HRES ET    | TEST      | SYS_X TALO  |
| Y  | LPC_C SZ      | VDD_I         | LPC_C ST         | VDD_I         | LPC_O E        |              |        |           |             |           |         |         |           |           |           |         |             |           |                |           |                     | J1850_TX      | TDI            | VSS        | TMS        | CKSTP_OUT |             |
| AA | LPC_R WB      | LPC_A CK      | PSC4_1           | LPC_C LK      | PSC4_3         | VSS          |        | VDD_MEM_I |             | VSS       | VSS     |         | VDD_MEM_I | VDD_MEM_I |           | VSS     | VSS         |           | CORE_P LL_AVDD |           | VSS                 | I2C_S DA      | VDD_I          | J1850_RX   | VDD_I      | TRST      |             |
| AB | PSC4_0        | VSS           | PSC4_2           | VSS           | PSC3_1         | MDQ1         | MVTT0  | MDQ5      | MDQ1_0      | VSS       | MVRE F  | MDQ1_9  | MDQ2_1    | MDQ2_7    | MDQ3_1    | MA1     | MA5         | VDD_MEM_I | MA14           | MCKE      | SPDIF_TXCLK         | I2C1_S CL     | I2C1_S DA      | VSS        | IRQ1       | TCK       |             |
| AC | PSC5_0        | PSC4_4        | PSC5_1           | PSC3_2        | VDD_MEM_I      | MDM0         | MDQ8   | VSS       | MDQ1_4      | VDD_MEM_I | MDQS_2  | VSS     | MDQ2_5    | VDD_MEM_I | MDQ3_0    | MBA1    | VSS         | MA7       | MA11           | VDD_MEM_I | MODT                | VSS           | I2C0_S CL      | SPDIF_RX   | I2C2_S CL  | IRQ0      |             |
| AD | PSC5_2        | PSC5_3        | VSS              | PSC3_3        | MDQS_0         | MDQ6         | MDQ1_1 | MDQS_1    | VDD_MEM_I   | MDQ1_6    | MDQ1_8  | MDQ2_0  | MDQ2_3    | MDQS_3    | MDQ2_9    | MBA0    | MA0         | MA4       | MA9            | MA13      | MWE                 | MCS           | CORE_P LL_AVSS | SPDIF_TX   | VSS        | I2C0_S DA |             |
| AE | VDD_I         | VDD_I         | PSC5_4           | MDQ2          | VDD_MEM_I      | MDQ7         | VSS    | MDM1      | MDQ1_2      | VDD_MEM_I | MVTT2   | VSS     | MDQ2_4    | MVTT3     | VDD_MEM_I | MDQ2_8  | VSS         | MA2       | MA6            | VDD_MEM_I | MA12                | MA15          | VSS            | VDD_I      | VDD_I      | VSS       |             |
| AF |               | VDD_I         | PSC3_0           | PSC3_4        | MDQ0           | MDQ3         | MDQ4   | MDQ9      | MVTT1       | MDQ1_3    | MDQ1_5  | MDQ1_7  | MDM2      | MDQ2_2    | MDQ2_6    | MDM3    | MCK         | MCK       | MBA2           | MA3       | MA8                 | MA10          | MRAS           | MCAS       | VDD_I      |           |             |

Figure 2. Ball Map for the MPC5121e 516 TEPBGA Package  
MPC5121E/MPC5123 Data Sheet, Rev. 5

## 2.2 Pinout Listings

Table 3 provides the pin-out listing for the MPC5121e/MPC5123.

**Table 3. MPC5121e/MPC5123 TE-PBGA Pinout Listing (Sheet 1 of 12)**

| Signal                                 | Package Pin Number | Pad Type | Power Supply           | Notes |
|--|--------------------|----------|------------------------|-------|
| <b>DDR Memory Interface (67 Total)</b> |                    |          |                        |       |
| MDQ0                                   | AF5                | DDR      | V <sub>DD_MEM_IO</sub> | —     |
| MDQ1                                   | AB6                | DDR      | V <sub>DD_MEM_IO</sub> | —     |
| MDQ2                                   | AE4                | DDR      | V <sub>DD_MEM_IO</sub> | —     |
| MDQ3                                   | AF6                | DDR      | V <sub>DD_MEM_IO</sub> | —     |
| MDQ4                                   | AF7                | DDR      | V <sub>DD_MEM_IO</sub> | —     |
| MDQ5                                   | AB8                | DDR      | V <sub>DD_MEM_IO</sub> | —     |
| MDQ6                                   | AD6                | DDR      | V <sub>DD_MEM_IO</sub> | —     |
| MDQ7                                   | AE6                | DDR      | V <sub>DD_MEM_IO</sub> | —     |
| MDQ8                                   | AC7                | DDR      | V <sub>DD_MEM_IO</sub> | —     |
| MDQ9                                   | AF8                | DDR      | V <sub>DD_MEM_IO</sub> | —     |
| MDQ10                                  | AB9                | DDR      | V <sub>DD_MEM_IO</sub> | —     |
| MDQ11                                  | AD7                | DDR      | V <sub>DD_MEM_IO</sub> | —     |
| MDQ12                                  | AE9                | DDR      | V <sub>DD_MEM_IO</sub> | —     |
| MDQ13                                  | AF10               | DDR      | V <sub>DD_MEM_IO</sub> | —     |
| MDQ14                                  | AC9                | DDR      | V <sub>DD_MEM_IO</sub> | —     |
| MDQ15                                  | AF11               | DDR      | V <sub>DD_MEM_IO</sub> | —     |
| MDQ16                                  | AD10               | DDR      | V <sub>DD_MEM_IO</sub> | —     |
| MDQ17                                  | AF12               | DDR      | V <sub>DD_MEM_IO</sub> | —     |
| MDQ18                                  | AD11               | DDR      | V <sub>DD_MEM_IO</sub> | —     |
| MDQ19                                  | AB12               | DDR      | V <sub>DD_MEM_IO</sub> | —     |
| MDQ20                                  | AD12               | DDR      | V <sub>DD_MEM_IO</sub> | —     |
| MDQ21                                  | AB13               | DDR      | V <sub>DD_MEM_IO</sub> | —     |
| MDQ22                                  | AF14               | DDR      | V <sub>DD_MEM_IO</sub> | —     |
| MDQ23                                  | AD13               | DDR      | V <sub>DD_MEM_IO</sub> | —     |
| MDQ24                                  | AE13               | DDR      | V <sub>DD_MEM_IO</sub> | —     |
| MDQ25                                  | AC13               | DDR      | V <sub>DD_MEM_IO</sub> | —     |
| MDQ26                                  | AF15               | DDR      | V <sub>DD_MEM_IO</sub> | —     |
| MDQ27                                  | AB14               | DDR      | V <sub>DD_MEM_IO</sub> | —     |
| MDQ28                                  | AE16               | DDR      | V <sub>DD_MEM_IO</sub> | —     |
| MDQ29                                  | AD15               | DDR      | V <sub>DD_MEM_IO</sub> | —     |
| MDQ30                                  | AC15               | DDR      | V <sub>DD_MEM_IO</sub> | —     |

**Table 3. MPC5121e/MPC5123 TE-PBGA Pinout Listing (Sheet 2 of 12)**

| Signal                   | Package Pin Number | Pad Type | Power Supply           | Notes |
|--------------------------|--------------------|----------|------------------------|-------|
| MDQ31                    | AB15               | DDR      | V <sub>DD_MEM_IO</sub> | —     |
| MDM0                     | AC6                | DDR      | V <sub>DD_MEM_IO</sub> | —     |
| MDM1                     | AE8                | DDR      | V <sub>DD_MEM_IO</sub> | —     |
| MDM2                     | AF13               | DDR      | V <sub>DD_MEM_IO</sub> | —     |
| MDM3                     | AF16               | DDR      | V <sub>DD_MEM_IO</sub> | —     |
| MDQS0                    | AD5                | DDR      | V <sub>DD_MEM_IO</sub> | —     |
| MDQS1                    | AD8                | DDR      | V <sub>DD_MEM_IO</sub> | —     |
| MDQS2                    | AC11               | DDR      | V <sub>DD_MEM_IO</sub> | —     |
| MDQS3                    | AD14               | DDR      | V <sub>DD_MEM_IO</sub> | —     |
| MBA0                     | AD16               | DDR      | V <sub>DD_MEM_IO</sub> | —     |
| MBA1                     | AC16               | DDR      | V <sub>DD_MEM_IO</sub> | —     |
| MBA2                     | AF19               | DDR      | V <sub>DD_MEM_IO</sub> | —     |
| MA0                      | AD17               | DDR      | V <sub>DD_MEM_IO</sub> | —     |
| MA1                      | AB16               | DDR      | V <sub>DD_MEM_IO</sub> | —     |
| MA2                      | AE18               | DDR      | V <sub>DD_MEM_IO</sub> | —     |
| MA3                      | AF20               | DDR      | V <sub>DD_MEM_IO</sub> | —     |
| MA4                      | AD18               | DDR      | V <sub>DD_MEM_IO</sub> | —     |
| MA5                      | AB17               | DDR      | V <sub>DD_MEM_IO</sub> | —     |
| MA6                      | AE19               | DDR      | V <sub>DD_MEM_IO</sub> | —     |
| MA7                      | AC18               | DDR      | V <sub>DD_MEM_IO</sub> | —     |
| MA8                      | AF21               | DDR      | V <sub>DD_MEM_IO</sub> | —     |
| MA9                      | AD19               | DDR      | V <sub>DD_MEM_IO</sub> | —     |
| MA10                     | AF22               | DDR      | V <sub>DD_MEM_IO</sub> | —     |
| MA11                     | AC19               | DDR      | V <sub>DD_MEM_IO</sub> | —     |
| MA12                     | AE21               | DDR      | V <sub>DD_MEM_IO</sub> | —     |
| MA13                     | AD20               | DDR      | V <sub>DD_MEM_IO</sub> | —     |
| MA14                     | AB19               | DDR      | V <sub>DD_MEM_IO</sub> | —     |
| MA15                     | AE22               | DDR      | V <sub>DD_MEM_IO</sub> | —     |
| $\overline{\text{MWE}}$  | AD21               | DDR      | V <sub>DD_MEM_IO</sub> | —     |
| $\overline{\text{MRAS}}$ | AF23               | DDR      | V <sub>DD_MEM_IO</sub> | —     |
| $\overline{\text{MCAS}}$ | AF24               | DDR      | V <sub>DD_MEM_IO</sub> | —     |
| $\overline{\text{MCS}}$  | AD22               | DDR      | V <sub>DD_MEM_IO</sub> | —     |
| MCKE                     | AB20               | DDR      | V <sub>DD_MEM_IO</sub> | —     |
| MCK                      | AF17               | DDR      | V <sub>DD_MEM_IO</sub> | —     |
| $\overline{\text{MCK}}$  | AF18               | DDR      | V <sub>DD_MEM_IO</sub> | —     |

**Table 3. MPC5121e/MPC5123 TE-PBGA Pinout Listing (Sheet 3 of 12)**

| Signal  | Package Pin Number | Pad Type   | Power Supply           | Notes |
|---|--------------------|------------|------------------------|-------|
| MODT  | AC21               | DDR        | V <sub>DD_MEM_IO</sub> | —     |
| <b>LPC Interface (8 Total)</b>                |                    |            |                        |       |
| LPC_CLK                                       | AA4                | General IO | V <sub>DD_IO</sub>     | —     |
| $\overline{\text{LPC\_OE}}$                   | Y5                 | General IO | V <sub>DD_IO</sub>     | —     |
| $\overline{\text{LPC\_R}\overline{\text{W}}}$ | AA1                | General IO | V <sub>DD_IO</sub>     | —     |
| $\overline{\text{LPC\_CS0}}$                  | W5                 | General IO | V <sub>DD_IO</sub>     | —     |
| $\overline{\text{LPC\_CS1}}$                  | Y3                 | General IO | V <sub>DD_IO</sub>     | —     |
| $\overline{\text{LPC\_CS2}}$                  | Y1                 | General IO | V <sub>DD_IO</sub>     | —     |
| $\overline{\text{LPC\_ACK}}$                  | AA2                | General IO | V <sub>DD_IO</sub>     | —     |
| LPC_AX03                                      | W4                 | General IO | V <sub>DD_IO</sub>     | —     |
| <b>EMB Interface (35 Total)</b>               |                    |            |                        |       |
| EMB_AX02                                      | W3                 | General IO | V <sub>DD_IO</sub>     | —     |
| EMB_AX01                                      | V5                 | General IO | V <sub>DD_IO</sub>     | —     |
| EMB_AX00                                      | W2                 | General IO | V <sub>DD_IO</sub>     | —     |
| EMB_AD31                                      | W1                 | General IO | V <sub>DD_IO</sub>     | —     |
| EMB_AD30                                      | V4                 | General IO | V <sub>DD_IO</sub>     | —     |
| EMB_AD29                                      | U5                 | General IO | V <sub>DD_IO</sub>     | —     |
| EMB_AD28                                      | V3                 | General IO | V <sub>DD_IO</sub>     | —     |
| EMB_AD27                                      | V2                 | General IO | V <sub>DD_IO</sub>     | —     |
| EMB_AD26                                      | V1                 | General IO | V <sub>DD_IO</sub>     | —     |
| EMB_AD25                                      | U1                 | General IO | V <sub>DD_IO</sub>     | —     |
| EMB_AD24                                      | U3                 | General IO | V <sub>DD_IO</sub>     | —     |
| EMB_AD23                                      | T5                 | General IO | V <sub>DD_IO</sub>     | —     |
| EMB_AD22                                      | T1                 | General IO | V <sub>DD_IO</sub>     | —     |
| EMB_AD21                                      | T4                 | General IO | V <sub>DD_IO</sub>     | —     |
| EMB_AD20                                      | T3                 | General IO | V <sub>DD_IO</sub>     | —     |
| EMB_AD19                                      | R5                 | General IO | V <sub>DD_IO</sub>     | —     |
| EMB_AD18                                      | T2                 | General IO | V <sub>DD_IO</sub>     | —     |
| EMB_AD17                                      | R1                 | General IO | V <sub>DD_IO</sub>     | —     |
| EMB_AD16                                      | R3                 | General IO | V <sub>DD_IO</sub>     | —     |
| EMB_AD15                                      | P1                 | General IO | V <sub>DD_IO</sub>     | —     |
| EMB_AD14                                      | P2                 | General IO | V <sub>DD_IO</sub>     | —     |
| EMB_AD13                                      | P4                 | General IO | V <sub>DD_IO</sub>     | —     |
| EMB_AD12                                      | P5                 | General IO | V <sub>DD_IO</sub>     | —     |



**Table 3. MPC5121e/MPC5123 TE-PBGA Pinout Listing (Sheet 4 of 12)**

| Signal                          | Package Pin Number | Pad Type   | Power Supply       | Notes           |
|---------------------------------|--------------------|------------|--------------------|-----------------|
| EMB_AD11                        | P3                 | General IO | V <sub>DD_IO</sub> | —               |
| EMB_AD10                        | N1                 | General IO | V <sub>DD_IO</sub> | —               |
| EMB_AD09                        | N2                 | General IO | V <sub>DD_IO</sub> | —               |
| EMB_AD08                        | N3                 | General IO | V <sub>DD_IO</sub> | —               |
| EMB_AD07                        | N4                 | General IO | V <sub>DD_IO</sub> | —               |
| EMB_AD06                        | M1                 | General IO | V <sub>DD_IO</sub> | —               |
| EMB_AD05                        | M3                 | General IO | V <sub>DD_IO</sub> | —               |
| EMB_AD04                        | M5                 | General IO | V <sub>DD_IO</sub> | —               |
| EMB_AD03                        | L1                 | General IO | V <sub>DD_IO</sub> | —               |
| EMB_AD02                        | L2                 | General IO | V <sub>DD_IO</sub> | —               |
| EMB_AD01                        | L3                 | General IO | V <sub>DD_IO</sub> | —               |
| EMB_AD00                        | L4                 | General IO | V <sub>DD_IO</sub> | —               |
| <b>PATA Interface (9 Total)</b> |                    |            |                    |                 |
| $\overline{\text{PATA\_CE1}}$   | K1                 | General IO | V <sub>DD_IO</sub> | ATA name: CS0   |
| $\overline{\text{PATA\_CE2}}$   | L5                 | General IO | V <sub>DD_IO</sub> | ATA name: CS1   |
| PATA_ISOLATE                    | K3                 | General IO | V <sub>DD_IO</sub> | —               |
| $\overline{\text{PATA\_IOR}}$   | J1                 | General IO | V <sub>DD_IO</sub> | ATA name: DIOR  |
| $\overline{\text{PATA\_IOW}}$   | K5                 | General IO | V <sub>DD_IO</sub> | ATA name: DIOW  |
| PATA_IOCHRDY                    | J2                 | General IO | V <sub>DD_IO</sub> | ATA name: IORDY |
| PATA_INTRQ                      | J3                 | General IO | V <sub>DD_IO</sub> | —               |
| PATA_DRQ                        | J4                 | General IO | V <sub>DD_IO</sub> | ATA name: DMARQ |
| $\overline{\text{PATA\_DACK}}$  | H2                 | General IO | V <sub>DD_IO</sub> | ATA name: DMACK |
| <b>NFC Interface (7 Total)</b>  |                    |            |                    |                 |
| $\overline{\text{NFC\_WP}}$     | G4                 | General IO | V <sub>DD_IO</sub> | —               |
| $\overline{\text{NFC\_R/B}}$    | H1                 | General IO | V <sub>DD_IO</sub> | —               |
| $\overline{\text{NFC\_WE}}$     | G3                 | General IO | V <sub>DD_IO</sub> | —               |
| $\overline{\text{NFC\_RE}}$     | G2                 | General IO | V <sub>DD_IO</sub> | —               |
| NFC_ALE                         | H4                 | General IO | V <sub>DD_IO</sub> | —               |
| NFC_CLE                         | H5                 | General IO | V <sub>DD_IO</sub> | —               |
| $\overline{\text{NFC\_CE0}}$    | H3                 | General IO | V <sub>DD_IO</sub> | —               |
| <b>I2C Interface (6 Total)</b>  |                    |            |                    |                 |
| I2C0_SCL                        | AC23               | General IO | V <sub>DD_IO</sub> | —               |
| I2C0_SDA                        | AD26               | General IO | V <sub>DD_IO</sub> | —               |
| I2C1_SCL                        | AB22               | General IO | V <sub>DD_IO</sub> | —               |

**Table 3. MPC5121e/MPC5123 TE-PBGA Pinout Listing (Sheet 5 of 12)**

| Signal                            | Package Pin Number | Pad Type     | Power Supply       | Notes |
|-----------------------------------|--------------------|--------------|--------------------|-------|
| I2C1_SDA                          | AB23               | General IO   | V <sub>DD_IO</sub> | —     |
| I2C2_SCL                          | AC25               | General IO   | V <sub>DD_IO</sub> | —     |
| I2C2_SDA                          | AA22               | General IO   | V <sub>DD_IO</sub> | —     |
| <b>IRQ Interface (2 Total)</b>    |                    |              |                    |       |
| $\overline{\text{IRQ0}}$          | AC26               | General IO   | V <sub>DD_IO</sub> | —     |
| $\overline{\text{IRQ1}}$          | AB25               | General IO   | V <sub>DD_IO</sub> | —     |
| <b>CAN Interface (4 Total)</b>    |                    |              |                    |       |
| CAN1_RX                           | C19                | Analog Input | VBAT_RTC           | —     |
| CAN1_TX                           | A18                | General IO   | V <sub>DD_IO</sub> | —     |
| CAN2_RX                           | B19                | Analog Input | VBAT_RTC           | —     |
| CAN2_TX                           | E16                | General IO   | V <sub>DD_IO</sub> | —     |
| <b>J1850 Interface (2 Total)</b>  |                    |              |                    |       |
| J1850_TX                          | Y22                | General IO   | V <sub>DD_IO</sub> | —     |
| J1850_RX                          | AA24               | General IO   | V <sub>DD_IO</sub> | —     |
| <b>SPDIF Interface (3 Total)</b>  |                    |              |                    |       |
| SPDIF_TXCLK                       | AB21               | General IO   | V <sub>DD_IO</sub> | —     |
| SPDIF_TX                          | AD24               | General IO   | V <sub>DD_IO</sub> | —     |
| SPDIF_RX                          | AC24               | General IO   | V <sub>DD_IO</sub> | —     |
| <b>PCI (54 Total)</b>             |                    |              |                    |       |
| $\overline{\text{PCI\_INTA}}$     | U23                | PCI          | V <sub>DD_IO</sub> | —     |
| $\overline{\text{PCI\_RST\_OUT}}$ | F22                | PCI          | V <sub>DD_IO</sub> | —     |
| PCI_AD00                          | U24                | PCI          | V <sub>DD_IO</sub> | —     |
| PCI_AD01                          | V26                | PCI          | V <sub>DD_IO</sub> | —     |
| PCI_AD02                          | U25                | PCI          | V <sub>DD_IO</sub> | —     |
| PCI_AD03                          | R22                | PCI          | V <sub>DD_IO</sub> | —     |
| PCI_AD04                          | U26                | PCI          | V <sub>DD_IO</sub> | —     |
| PCI_AD05                          | T24                | PCI          | V <sub>DD_IO</sub> | —     |
| PCI_AD06                          | R23                | PCI          | V <sub>DD_IO</sub> | —     |
| PCI_AD07                          | T26                | PCI          | V <sub>DD_IO</sub> | —     |
| PCI_AD08                          | R26                | PCI          | V <sub>DD_IO</sub> | —     |
| PCI_AD09                          | P23                | PCI          | V <sub>DD_IO</sub> | —     |
| PCI_AD10                          | R24                | PCI          | V <sub>DD_IO</sub> | —     |
| PCI_AD11                          | R25                | PCI          | V <sub>DD_IO</sub> | —     |
| PCI_AD12                          | P26                | PCI          | V <sub>DD_IO</sub> | —     |

**Table 3. MPC5121e/MPC5123 TE-PBGA Pinout Listing (Sheet 6 of 12)**

| Signal                          | Package Pin Number | Pad Type | Power Supply       | Notes |
|---------------------------------|--------------------|----------|--------------------|-------|
| PCI_AD13                        | P24                | PCI      | V <sub>DD_IO</sub> | —     |
| PCI_AD14                        | P25                | PCI      | V <sub>DD_IO</sub> | —     |
| PCI_AD15                        | N26                | PCI      | V <sub>DD_IO</sub> | —     |
| PCI_AD16                        | L22                | PCI      | V <sub>DD_IO</sub> | —     |
| PCI_AD17                        | K25                | PCI      | V <sub>DD_IO</sub> | —     |
| PCI_AD18                        | J26                | PCI      | V <sub>DD_IO</sub> | —     |
| PCI_AD19                        | K24                | PCI      | V <sub>DD_IO</sub> | —     |
| PCI_AD20                        | J25                | PCI      | V <sub>DD_IO</sub> | —     |
| PCI_AD21                        | H26                | PCI      | V <sub>DD_IO</sub> | —     |
| PCI_AD22                        | K23                | PCI      | V <sub>DD_IO</sub> | —     |
| PCI_AD23                        | J24                | PCI      | V <sub>DD_IO</sub> | —     |
| PCI_AD24                        | H24                | PCI      | V <sub>DD_IO</sub> | —     |
| PCI_AD25                        | J23                | PCI      | V <sub>DD_IO</sub> | —     |
| PCI_AD26                        | G25                | PCI      | V <sub>DD_IO</sub> | —     |
| PCI_AD27                        | J22                | PCI      | V <sub>DD_IO</sub> | —     |
| PCI_AD28                        | F26                | PCI      | V <sub>DD_IO</sub> | —     |
| PCI_AD29                        | G24                | PCI      | V <sub>DD_IO</sub> | —     |
| PCI_AD30                        | F24                | PCI      | V <sub>DD_IO</sub> | —     |
| PCI_AD31                        | H22                | PCI      | V <sub>DD_IO</sub> | —     |
| PCI_C/ $\overline{\text{BE}}0$  | P22                | PCI      | V <sub>DD_IO</sub> | —     |
| PCI_C/ $\overline{\text{BE}}1$  | N24                | PCI      | V <sub>DD_IO</sub> | —     |
| PCI_C/ $\overline{\text{BE}}2$  | L24                | PCI      | V <sub>DD_IO</sub> | —     |
| PCI_C/ $\overline{\text{BE}}3$  | G26                | PCI      | V <sub>DD_IO</sub> | —     |
| PCI_PAR                         | N22                | PCI      | V <sub>DD_IO</sub> | —     |
| $\overline{\text{PCI\_FRAME}}$  | M23                | PCI      | V <sub>DD_IO</sub> | 1     |
| $\overline{\text{PCI\_TRDY}}$   | M22                | PCI      | V <sub>DD_IO</sub> | 1     |
| $\overline{\text{PCI\_IRDY}}$   | K26                | PCI      | V <sub>DD_IO</sub> | 1     |
| $\overline{\text{PCI\_STOP}}$   | M24                | PCI      | V <sub>DD_IO</sub> | 1     |
| $\overline{\text{PCI\_DEVSEL}}$ | L26                | PCI      | V <sub>DD_IO</sub> | 1     |
| PCI_IDSEL                       | K22                | PCI      | V <sub>DD_IO</sub> | —     |
| $\overline{\text{PCI\_SERR}}$   | M26                | PCI      | V <sub>DD_IO</sub> | 1     |
| $\overline{\text{PCI\_PERR}}$   | M25                | PCI      | V <sub>DD_IO</sub> | 1     |
| PCI_REQ0                        | G23                | PCI      | V <sub>DD_IO</sub> | 1     |
| PCI_REQ1                        | E26                | PCI      | V <sub>DD_IO</sub> | 1     |
| $\overline{\text{PCI\_REQ2}}$   | D26                | PCI      | V <sub>DD_IO</sub> | 1     |

**Table 3. MPC5121e/MPC5123 TE-PBGA Pinout Listing (Sheet 7 of 12)**

| Signal                          | Package Pin Number | Pad Type   | Power Supply       | Notes |
|---------------------------------|--------------------|------------|--------------------|-------|
| PCI_GNT0                        | E25                | PCI        | V <sub>DD_IO</sub> | —     |
| PCI_GNT1                        | G22                | PCI        | V <sub>DD_IO</sub> | —     |
| PCI_GNT2                        | E24                | PCI        | V <sub>DD_IO</sub> | —     |
| PCI_CLK                         | C26                | PCI        | V <sub>DD_IO</sub> | —     |
| <b>PSC Interface (61 Total)</b> |                    |            |                    |       |
| PSC_MCLK_IN                     | C17                | General IO | V <sub>DD_IO</sub> | —     |
| PSC0_0                          | D16                | General IO | V <sub>DD_IO</sub> | —     |
| PSC0_1                          | A17                | General IO | V <sub>DD_IO</sub> | —     |
| PSC0_2                          | E15                | General IO | V <sub>DD_IO</sub> | —     |
| PSC0_3                          | C16                | General IO | V <sub>DD_IO</sub> | —     |
| PSC0_4                          | B16                | General IO | V <sub>DD_IO</sub> | —     |
| PSC1_0                          | C15                | General IO | V <sub>DD_IO</sub> | —     |
| PSC1_1                          | A16                | General IO | V <sub>DD_IO</sub> | —     |
| PSC1_2                          | E14                | General IO | V <sub>DD_IO</sub> | —     |
| PSC1_3                          | A15                | General IO | V <sub>DD_IO</sub> | —     |
| PSC1_4                          | D14                | General IO | V <sub>DD_IO</sub> | —     |
| PSC2_0                          | C14                | General IO | V <sub>DD_IO</sub> | —     |
| PSC2_1                          | B14                | General IO | V <sub>DD_IO</sub> | —     |
| PSC2_2                          | E13                | General IO | V <sub>DD_IO</sub> | —     |
| PSC2_3                          | A14                | General IO | V <sub>DD_IO</sub> | —     |
| PSC2_4                          | D13                | General IO | V <sub>DD_IO</sub> | —     |
| PSC3_0                          | AF3                | General IO | V <sub>DD_IO</sub> | —     |
| PSC3_1                          | AB5                | General IO | V <sub>DD_IO</sub> | —     |
| PSC3_2                          | AC4                | General IO | V <sub>DD_IO</sub> | —     |
| PSC3_3                          | AD4                | General IO | V <sub>DD_IO</sub> | —     |
| PSC3_4                          | AF4                | General IO | V <sub>DD_IO</sub> | —     |
| PSC4_0                          | AB1                | General IO | V <sub>DD_IO</sub> | —     |
| PSC4_1                          | AA3                | General IO | V <sub>DD_IO</sub> | —     |
| PSC4_2                          | AB3                | General IO | V <sub>DD_IO</sub> | —     |
| PSC4_3                          | AA5                | General IO | V <sub>DD_IO</sub> | —     |
| PSC4_4                          | AC2                | General IO | V <sub>DD_IO</sub> | —     |
| PSC5_0                          | AC1                | General IO | V <sub>DD_IO</sub> | —     |
| PSC5_1                          | AC3                | General IO | V <sub>DD_IO</sub> | —     |
| PSC5_2                          | AD1                | General IO | V <sub>DD_IO</sub> | —     |

**Table 3. MPC5121e/MPC5123 TE-PBGA Pinout Listing (Sheet 8 of 12)**

| Signal                | Package Pin Number | Pad Type   | Power Supply       | Notes |
|-----------------------|--------------------|------------|--------------------|-------|
| PSC5_3                | AD2                | General IO | V <sub>DD_IO</sub> | —     |
| PSC5_4                | AE3                | General IO | V <sub>DD_IO</sub> | —     |
| PSC6_0                | A11                | General IO | V <sub>DD_IO</sub> | —     |
| PSC6_1                | C10                | General IO | V <sub>DD_IO</sub> | —     |
| PSC6_2                | A10                | General IO | V <sub>DD_IO</sub> | —     |
| PSC6_3                | B9                 | General IO | V <sub>DD_IO</sub> | —     |
| PSC6_4                | A9                 | General IO | V <sub>DD_IO</sub> | —     |
| PSC7_0                | B8                 | General IO | V <sub>DD_IO</sub> | —     |
| PSC7_1                | E10                | General IO | V <sub>DD_IO</sub> | —     |
| PSC7_2                | C8                 | General IO | V <sub>DD_IO</sub> | —     |
| PSC7_3                | A8                 | General IO | V <sub>DD_IO</sub> | —     |
| PSC7_4                | A7                 | General IO | V <sub>DD_IO</sub> | —     |
| PSC8_0                | E9                 | General IO | V <sub>DD_IO</sub> | —     |
| PSC8_1                | D8                 | General IO | V <sub>DD_IO</sub> | —     |
| PSC8_2                | C7                 | General IO | V <sub>DD_IO</sub> | —     |
| PSC8_3                | B6                 | General IO | V <sub>DD_IO</sub> | —     |
| PSC8_4                | E8                 | General IO | V <sub>DD_IO</sub> | —     |
| PSC9_0                | C6                 | General IO | V <sub>DD_IO</sub> | —     |
| PSC9_1                | D7                 | General IO | V <sub>DD_IO</sub> | —     |
| PSC9_2                | E7                 | General IO | V <sub>DD_IO</sub> | —     |
| PSC9_3                | D6                 | General IO | V <sub>DD_IO</sub> | —     |
| PSC9_4                | E6                 | General IO | V <sub>DD_IO</sub> | —     |
| PSC10_0               | C13                | General IO | V <sub>DD_IO</sub> | —     |
| PSC10_1               | B13                | General IO | V <sub>DD_IO</sub> | —     |
| PSC10_2               | A13                | General IO | V <sub>DD_IO</sub> | —     |
| PSC10_3               | C12                | General IO | V <sub>DD_IO</sub> | —     |
| PSC10_4               | E12                | General IO | V <sub>DD_IO</sub> | —     |
| PSC11_0               | A12                | General IO | V <sub>DD_IO</sub> | —     |
| PSC11_1               | B11                | General IO | V <sub>DD_IO</sub> | —     |
| PSC11_2               | C11                | General IO | V <sub>DD_IO</sub> | —     |
| PSC11_3               | E11                | General IO | V <sub>DD_IO</sub> | —     |
| PSC11_4               | D11                | General IO | V <sub>DD_IO</sub> | —     |
| <b>JTAG (5 Total)</b> |                    |            |                    |       |
| TCK                   | AB26               | General IO | V <sub>DD_IO</sub> | 2     |

**Table 3. MPC5121e/MPC5123 TE-PBGA Pinout Listing (Sheet 9 of 12)**

| Signal   | Package Pin Number | Pad Type      | Power Supply                          | Notes                |
|--|--------------------|---------------|---------------------------------------|----------------------|
| TDI  | Y23                | General IO    | V <sub>DD_IO</sub>                    | 3                    |
| TDO  | W22                | General IO    | V <sub>DD_IO</sub>                    | —                    |
| TMS  | Y25                | General IO    | V <sub>DD_IO</sub>                    | 3                    |
| $\overline{\text{TRST}}$                                     | AA26               | General IO    | V <sub>DD_IO</sub>                    | 3                    |
| <b>Test / Debug (2 Total)</b>                                |                    |               |                                       |                      |
| TEST   | W25                | General IO    | V <sub>DD_IO</sub>                    | 4, 5                 |
| $\overline{\text{CKSTP\_OUT}}$                               | Y26                | General IO    | V <sub>DD_IO</sub>                    | —                    |
| <b>System Control (3 Total)</b>                              |                    |               |                                       |                      |
| $\overline{\text{HRESET}}$                                   | W24                | General IO    | V <sub>DD_IO</sub>                    | 6, 2                 |
| $\overline{\text{PORESET}}$                                  | W23                | General IO    | V <sub>DD_IO</sub>                    | 4, 2                 |
| $\overline{\text{SRESET}}$                                   | V22                | General IO    | V <sub>DD_IO</sub>                    | 6, 2                 |
| <b>System Clock (2 Total)</b>                                |                    |               |                                       |                      |
| SYS_XTALI  | V24                | Analog Input  | SYS_PLL_AVDD                          | Oscillator Input     |
| SYS_XTALO  | W26                | Analog Output | SYS_PLL_AVDD                          | Oscillator Output    |
| <b>RTC (3 Total)</b>   |                    |               |                                       |                      |
| RTC_XTALI  | C20                | Analog Input  | VBAT_RTC                              | Oscillator Input     |
| RTC_XTALO  | A20                | Analog Output | VBAT_RTC                              | Oscillator Output    |
| $\overline{\text{HIB\_MODE}}$                                | D18                | Analog Output | VBAT_RTC                              | —                    |
| <b>GP Input Only (4 Total)</b>                               |                    |               |                                       |                      |
| GPIO28   | A19                | Analog Input  | VBAT_RTC                              | —                    |
| GPIO29   | E17                | Analog Input  | VBAT_RTC                              | —                    |
| GPIO30   | C18                | Analog Input  | VBAT_RTC                              | —                    |
| GPIO31   | B18                | Analog Input  | VBAT_RTC                              | —                    |
| <b>DDR Reference Voltage</b>                                 |                    |               |                                       |                      |
| MVREF  | AB11               | Analog Input  | Voltage Reference for SSTL input pads |                      |
| <b>USB – PHY without Power and Ground Supplies (7 Total)</b> |                    |               |                                       |                      |
| USB_XTALI  | C24                | Analog Input  | USB_PLL_PWR3                          | Oscillator Input     |
| USB_XTALO  | B24                | Analog Output | USB_PLL_PWR3                          | Oscillator Output    |
| USB_DP   | A23                | Analog IO     | USB_VDDA                              | —                    |
| USB_DM   | A22                | Analog IO     | USB_VDDA                              | —                    |
| USB_TPA  | A24                | Analog Output | —                                     | USB PHY debug output |
| USB_VBUS   | D21                | Analog IO     | —                                     | —                    |

**Table 3. MPC5121e/MPC5123 TE-PBGA Pinout Listing (Sheet 10 of 12)**

| Signal  | Package Pin Number   | Pad Type      | Power Supply       | Notes                 |
|---|--|---------------|--------------------|-----------------------|
| USB_UID   | E19  | Analog Input  | —                  | —                     |
| <b>USB digital IOs (2 Total)</b>                                |  |               |                    |                       |
| USB2_VBUS_PWR_FAULT   | B21  | General IO    | V <sub>DD_IO</sub> | —                     |
| USB2_DRVVBUS  | A21  | General IO    | V <sub>DD_IO</sub> | —                     |
| <b>SATA PHY without Power and Ground Supplies (7 Total)</b>     |  |               |                    |                       |
| SATA_XTALI  | C3   | Analog Input  | SATA_VDDA_3P3      | Oscillator Input      |
| SATA_XTALO  | C2   | Analog Output | SATA_VDDA_3P3      | Oscillator Output     |
| SATA_ANAVIZ   | E5   | Analog Output | —                  | SATA PHY debug output |
| SATA_TXN  | E1   | Analog Output | SATA_VDDA_1P2      | —                     |
| SATA_TXP  | F1   | Analog Output | SATA_VDDA_1P2      | —                     |
| SATA_RXP  | A5   | Analog Input  | SATA_VDDA_1P2      | —                     |
| SATA_RXN  | A4   | Analog Input  | SATA_VDDA_1P2      | —                     |
| <b>Power and Ground Supplies (without SATA PHY and USB PHY)</b> |  |               |                    |                       |
| V <sub>DD_CORE</sub>  | K10, K11, K12, K13, K14, K15, K16, K17, L10, L17, M10, M17, N10, N17, P10, P17, R10, R17, T10, T17, U10, U11, U12, U13, U14, U15, U16, U17   | Power         | —                  | —                     |
| V <sub>DD_IO</sub>  | B10, B15, B25, D9, D10, D15, F11, F13, F14, F19, F23, F25, H21, J5, K2, K4, L23, L25, N6, N21, P6, P21, R2, R4, T23, T25, W6, W21, Y2, Y4, AA23, AA25, AE1, AE2, AE24, AE25, AF2, AF25 | Power         | —                  | —                     |
| V <sub>DD_MEM_IO</sub>  | AA8, AA13, AA14, AB18, AC5, AC10, AC14, AC20, AD9, AE5, AE10, AE15, AE20   | Power         | —                  | —                     |

**Table 3. MPC5121e/MPC5123 TE-PBGA Pinout Listing (Sheet 11 of 12)**

| Signal                                     | Package Pin Number  | Pad Type      | Power Supply                         | Notes |
|--|---|---------------|--------------------------------------|-------|
| V <sub>SS</sub>                            | A2, A3, A25, B1,B2, B3, B5, B7, B12, B17, B20, B22, B26, C1, C4, C23, C25, D2, D12, D17, D24, D25, E18, F2, F3, F4, F5, F6, F8, F10, F16, F17, F21, G5, H6, H23, H25, K6, K21, L6, L11, L12, L13, L14, L15, L16, L21, M2, M4, M11, M12, M13, M14, M15, M16, N5, N11, N12, N13, N14, N15, N16, | Ground        | —                                    | —     |
| V <sub>SS</sub>                            | N23, N25, P11, P12, P13, P14, P15, P16, R11, R12, R13, R14, R15, R16, T6, T11, T12, T13, T14, T15, T16, T21, U2, U4, U6, U21, V23, V25, Y24, AA6, AA10, AA11, AA16, AA17, AA21, AB2, AB4, AB10, AB24, AC8, AC12, AC17, AC22, AD3, AD25, AE7, AE12, AE17, AE23, AE26                           | Ground        | —                                    | —     |
| SYS_PLL_AVDD                               | T22   | Analog Power  | —                                    | —     |
| SYS_PLL_AVSS                               | U22   | Analog Ground | —                                    | —     |
| CORE_PLL_AVDD                              | AA19  | Analog Power  | —                                    | —     |
| CORE_PLL_AVSS                              | AD23  | Analog Ground | —                                    | —     |
| VBAT_RTC                                   | D19   | Power         | —                                    | —     |
| AVDD_FUSEWR                                | C9  | Power         | —                                    | —     |
| MVTT0                                      | AB7   | Analog Input  | SSTL(DDR2) Termination (ODT) Voltage |       |
| MVTT1                                      | AF9   | Analog Input  | SSTL(DDR2) Termination (ODT) Voltage |       |
| MVTT2                                      | AE11  | Analog Input  | SSTL(DDR2) Termination (ODT) Voltage |       |
| MVTT3                                      | AE14  | Analog Input  | SSTL(DDR2) Termination (ODT) Voltage |       |
| <b>Power and Ground Supplies (USB PHY)</b> |   |               |                                      |       |
| USB_PLL_GND                                | E23   | Analog Ground | —                                    | —     |
| USB_PLL_PWR3                               | D23   | Analog Power  | —                                    | —     |
| USB_RREF                                   | E22   | Analog Power  | —                                    | —     |
| USB_VSSA_BIAS                              | B23   | Analog Ground | —                                    | —     |



**Table 3. MPC5121e/MPC5123 TE-PBGA Pinout Listing (Sheet 12 of 12)**

| Signal                                      | Package Pin Number | Pad Type      | Power Supply | Notes |
|---|--------------------|---------------|--------------|-------|
| USB_VDDA_BIAS                               | D22                | Analog Power  | —            | —     |
| USB_VSSA                                    | C22, E20, E21      | Analog Ground | —            | —     |
| USB_VDDA                                    | C21, D20           | Analog Power  | —            | —     |
| <b>Power and Ground Supplies (SATA PHY)</b> |                    |               |              |       |
| SATA_RESREF                                 | E4                 | Analog Power  | —            | —     |
| SATA_VDDA_3P3                               | D4                 | Analog Power  | —            | —     |
| SATA_VDDA_1P2                               | C5, D1, E2         | Analog Power  | —            | —     |
| SATA_VDDA_VREG                              | D5                 | Analog Power  | —            | —     |
| SATA_PLL_VDDA1P2                            | E3                 | Analog Power  | —            | —     |
| SATA_PLL_VSSA                               | D3                 | Analog Ground | —            | —     |
| SATA_RX_VSSA                                | A6, B4             | Analog Ground | —            | —     |
| SATA_TX_VSSA                                | G1                 | Analog Ground | —            | —     |

<sup>1</sup> This pins should have an external pull-up resistor. Follow PCI specification and see System Design Information.

<sup>2</sup> This pin contains an enabled internal Schmitt trigger.

<sup>3</sup> These JTAG pins have internal pull-up P-FETs. This pin can not be configured.

<sup>4</sup> This pin is an input only. This pin can not be configured.

<sup>5</sup> This test pin must be tied to  $V_{SS}$ .

<sup>6</sup> This pin is an input or open-drain output. This pin can not be configured. There is an internal pull-up resistor implemented.

### NOTE

This table indicates only the pins with permanently enabled internal pull-up, pull-down, or Schmitt trigger. Most of the digital I/O pins can be configured to enable internal pull-up, pull-down, or Schmitt trigger. See the *MPC5121e Microcontroller Reference Manual*, IO Control chapter.

### 3 Electrical and Thermal Characteristics

#### 3.1 DC Electrical Characteristics

##### 3.1.1 Absolute Maximum Ratings

The tables in this section describe the MPC5121e/MPC5123 DC Electrical characteristics. [Table 4](#) gives the absolute maximum ratings.

**Table 4. Absolute Maximum Ratings<sup>1</sup>**

| Characteristic                                  | Symbol                                      | Min  | Max                          | Unit | SpecID |
|---|---|------|------------------------------|------|--------|
| Supply voltage – e300 core and peripheral logic | V <sub>DD_CORE</sub>                        | -0.3 | 1.47                         | V    | D1.1   |
| Supply voltage – I/O buffers                    | V <sub>DD_IO</sub> , V <sub>DD_MEM_IO</sub> | -0.3 | 3.6                          | V    | D1.2   |
| Input reference voltage (DDR/DDR2)              | MVREF                                       | -0.3 | 3.6                          | V    |        |
| Termination Voltage (DDR2)                      | MVTT  | -0.3 | 3.6                          | V    |        |
| Supply voltage – System APLL, System Oscillator | SYS_PLL_AVDD                                | -0.3 | 3.6                          | V    | D1.3   |
| Supply voltage – e300 APLL                      | CORE_PLL_AVDD                               | -0.3 | 3.6                          | V    | D1.4   |
| Supply voltage – RTC (Hibernation)              | VBAT_RTC                                    | -0.3 | 3.6                          | V    | D1.5   |
| Supply voltage – FUSE Programming               | AVDD_FUSEWR                                 | -0.3 | 3.6                          | V    | D1.6   |
| Supply voltage – SATA PHY analog                | SATA_VDDA_3P3                               | -0.3 | 3.6                          | V    | D1.8   |
| Supply voltage – SATA PHY voltage regulator     | SATA_VDDA_VREG                              | -0.3 | 2.6                          | V    | D1.9   |
| Supply voltage – SATA PHY Tx/Rx                 | SATA_VDDA_1P2                               | -0.3 | 1.47                         | V    | D1.10  |
| Supply voltage – SATA PHY PLL                   | SATA_PLL_VDDA1P2                            | -0.3 | 1.47                         | V    | D1.11  |
| Supply voltage – USB PHY PLL and OSC            | USB_PLL_PWR3                                | -0.3 | 3.6                          | V    | D1.12  |
| Supply voltage – USB PHY transceiver            | USB_VDDA                                    | -0.3 | 3.6                          | V    | D1.13  |
| Supply voltage – USB PHY bandgap bias           | USB_VDDA_BIAS                               | -0.3 | 3.6                          | V    | D1.14  |
| Input voltage – USB PHY cable                   | USB_VBUS                                    | -0.3 | 3.6                          | V    | D1.15  |
| Input voltage (V <sub>DD_IO</sub> )             | V <sub>in</sub>                             | -0.3 | V <sub>DD_IO</sub> + 0.3     | V    | D1.16  |
| Input voltage (V <sub>DD_MEM_IO</sub> )         | V <sub>in</sub>                             | -0.3 | V <sub>DD_MEM_IO</sub> + 0.3 | V    | D1.17  |
| Input voltage (VBAT_RTC)                        | V <sub>in</sub>                             | -0.3 | VBAT_RTC + 0.3               | V    | D1.18  |
| Input voltage overshoot                         | V <sub>inos</sub>                           | —    | 1                            | V    | D1.19  |
| Input voltage undershoot                        | V <sub>inus</sub>                           | —    | 1                            | V    | D1.20  |
| Storage temperature range                       | T <sub>stg</sub>                            | -55  | 150                          | °C   | D1.21  |

<sup>1</sup> Absolute maximum ratings are stress ratings only, and functional operation at the maximums is not guaranteed. Stresses beyond those listed may affect device reliability or cause permanent damage.

### 3.1.2 Recommended Operating Conditions

Table 5 gives the recommended operating conditions.

**Table 5. Recommended Operating Conditions**

| Characteristic  | Symbol  | Min <sup>1</sup>              | Typ                           | Max <sup>1</sup>              | Unit | SpecID |
|---|---|-------------------------------|-------------------------------|-------------------------------|------|--------|
| Supply voltage – e300 core and peripheral logic                       | $V_{DD\_CORE}$                                      | 1.33                          | 1.4                           | 1.47                          | V    | D2.1   |
| State Retention voltage – e300 core and peripheral logic <sup>2</sup> |   | 1.08                          | —                             | —                             | V    | D2.2   |
| Supply voltage – standard I/O buffers                                 | $V_{DD\_IO}$  | 3.0                           | 3.3                           | 3.6                           | V    | D2.3   |
| Supply voltage – memory I/O buffers (DDR)                             | $V_{DD\_MEM\_IO\_DDR}$                              | 2.3                           | 2.5                           | 2.7                           | V    | D2.4   |
| Supply voltage – memory I/O buffers (DDR2, LPDDR)                     | $V_{DD\_MEM\_IO\_DDR2}$<br>$V_{DD\_MEM\_IO\_LPDDR}$ | 1.7                           | 1.8                           | 1.9                           | V    | D2.5   |
| Input Reference Voltage (DDR/DDR2)                                    | MVREF   | $0.49 \times V_{DD\_MEM\_IO}$ | $0.50 \times V_{DD\_MEM\_IO}$ | $0.51 \times V_{DD\_MEM\_IO}$ | V    | D2.6   |
| Termination Voltage (DDR2)  | MVTT  | MVREF – 0.04                  | MVREF                         | MVREF + 0.04                  | V    | D2.7   |
| Supply voltage – System APLL, System Oscillator                       | SYS_PLL_AVDD  | 3.0                           | 3.3                           | 3.6                           | V    | D2.8   |
| Supply voltage – e300 APLL  | CORE_PLL_AVDD                                       | 3.0                           | 3.3                           | 3.6                           | V    | D2.9   |
| Supply voltage – RTC (Hibernation) <sup>3</sup>                       | VBAT_RTC  | 3.0                           | 3.3                           | 3.6                           | V    | D2.10  |
| Supply voltage – FUSE Programming                                     | AVDD_FUSEWR   | 3.3                           |                               | 3.6                           | V    | D2.11  |
| Supply voltage – SATA PHY analog and OSC                              | SATA_VDDA_3P3                                       | 3.0                           | 3.3                           | 3.6                           | V    | D2.13  |
| Supply voltage – SATA PHY voltage regulator                           | SATA_VDDA_VREG                                      | 1.7                           |                               | 2.6                           | V    | D2.14  |
| Supply voltage – SATA PHY Tx/Rx                                       | SATA_VDDA_1P2                                       | 1.14                          | 1.2                           | 1.47                          | V    | D2.15  |
| Supply voltage – SATA PHY PLL   | SATA_PLL_VDDA1P2                                    | 1.33                          | 1.4                           | 1.47                          | V    | D2.16  |
| Supply voltage – USB PHY PLL and OSC                                  | USB_PLL_PWR3  | 3.0                           | 3.3                           | 3.6                           | V    | D2.17  |
| Supply voltage – USB PHY transceiver                                  | USB_VDDA  | 3.0                           | 3.3                           | 3.6                           | V    | D2.18  |
| Supply voltage – USB PHY bandgap bias                                 | USB_VDDA_BIAS                                       | 3.0                           | 3.3                           | 3.6                           | V    | D2.19  |
| Input voltage – USB PHY cable   | USB_VBUS  | 1.4                           | —                             | 3.6                           | V    | D2.20  |
| Input voltage – standard I/O buffers                                  | $V_{in}$  | 0                             | —                             | $V_{DD\_IO}$                  | V    | D2.21  |
| Input voltage – memory I/O buffers (DDR)                              | $V_{in\_DDR}$                                       | 0                             | —                             | $V_{DD\_MEM\_IO\_DDR}$        | V    | D2.22  |
| Input voltage – memory I/O buffers (DDR2)                             | $V_{in\_DDR2}$                                      | 0                             | —                             | $V_{DD\_MEM\_IO\_DDR2}$       | V    | D2.23  |
| Input voltage – memory I/O buffers (LPDDR)                            | $V_{in\_LPDDR}$                                     | 0                             | —                             | $V_{DD\_MEM\_IO\_LPDDR}$      | V    | D2.24  |
| Ambient operating temperature range                                   | TA  | –40                           | —                             | +85                           | °C   | D2.25  |
| Junction operating temperature range                                  | TJ  | –40                           | —                             | +125                          | °C   | D2.26  |

<sup>1</sup> These are recommended and tested operating conditions. Proper device operation outside these conditions is not guaranteed.

<sup>2</sup> The State Retention voltage can be applied to  $V_{DD\_CORE}$  after the device is placed in Deep-Sleep mode.

<sup>3</sup> VBAT\_RTC should not be supplied by a battery of voltage less than 3.0 V.

### 3.1.3 DC Electrical Specifications

Table 6 gives the DC Electrical characteristics for the MPC5121e/MPC5123 at recommended operating conditions.

**Table 6. DC Electrical Specifications**

| Characteristic        | Condition  | Symbol    | Min  | Max  | Unit    | SpecID |
|-----------------------|--|-----------|--|--|---------|--------|
| Input high voltage    | Input type = TTL $V_{DD\_IO}$  | $V_{IH}$  | $0.51 \times V_{DD\_IO}$                         | —  | V       | D3.1   |
| Input high voltage    | Input type = TTL $V_{DD\_MEM\_IO\_DDR}$  | $V_{IH}$  | MVREF + 0.15                                     | —  | V       | D3.2   |
| Input high voltage    | Input type = TTL $V_{DD\_MEM\_IO\_DDR2}$   | $V_{IH}$  | MVREF + 0.125                                    | —  | V       | D3.3   |
| Input high voltage    | Input type = TTL $V_{DD\_MEM\_IO\_LPDDR}$  | $V_{IH}$  | $0.7 \times V_{DD\_MEM\_IO\_LPDDR}$              | —  | V       | D3.4   |
| Input high voltage    | Input type = PCI $V_{DD\_IO}$  | $V_{IH}$  | $0.5 \times V_{DD\_IO}$                          | —  | V       | D3.5   |
| Input high voltage    | Input type = Schmitt $V_{DD\_IO}$  | $V_{IH}$  | $0.65 \times V_{DD\_IO}$                         | —  | V       | D3.6   |
| Input high voltage    | SYS_XTALI crystal mode <sup>1</sup><br>Bypass mode <sup>2</sup>                            | $CV_{IH}$ | $V_{xtal} + 0.4V$<br>$(V_{DD\_IO}/2) + 0.4V$     | —  | V       | D3.7   |
| Input high voltage    | SATA_XTALI crystal mode<br>Bypass mode   | $SV_{IH}$ | $V_{xtal} + 0.4V$<br>$(V_{DD\_IO}/2) + 0.4V$     | —  | V       | D3.8   |
| Input high voltage    | USB_XTALI crystal mode<br>Bypass mode  | $UV_{IH}$ | $V_{xtal} + 0.4V$<br>$(V_{DD\_IO}/2) + 0.4V$     | —  | V       | D3.9   |
| Input high voltage    | RTC_XTALI crystal mode <sup>3</sup><br>Bypass mode <sup>4</sup>                            | $RV_{IH}$ | $(VBAT\_RTC/5) + 0.5V$<br>$(VBAT\_RTC/2) + 0.4V$ | —  | V       | D3.10  |
| Input low voltage     | Input type = TTL $V_{DD\_IO}$  | $V_{IL}$  | —  | $0.42 \times V_{DD\_IO}$                       | V       | D3.11  |
| Input low voltage     | Input type = TTL $V_{DD\_MEM\_IO\_DDR}$  | $V_{IL}$  | —  | MVREF – 0.15                                   | V       | D3.12  |
| Input low voltage     | Input type = TTL $V_{DD\_MEM\_IO\_DDR2}$   | $V_{IL}$  | —  | MVREF – 0.125                                  | V       | D3.13  |
| Input low voltage     | Input type = TTL $V_{DD\_MEM\_IO\_LPDDR}$  | $V_{IL}$  | —  | $0.3 \times V_{DD\_MEM\_IO\_LPDDR}$            | V       | D3.14  |
| Input low voltage     | Input type = PCI $V_{DD\_IO}$  | $V_{IL}$  | —  | $0.3 \times V_{DD\_IO}$                        | V       | D3.15  |
| Input low voltage     | Input type = Schmitt $V_{DD\_IO}$  | $V_{IL}$  | —  | $0.35 \times V_{DD\_IO}$                       | V       | D3.16  |
| Input low voltage     | SYS_XTALI crystal mode<br>Bypass mode  | $CV_{IL}$ | —  | $V_{xtal} - 0.4$<br>$(V_{DD\_IO}/2) - 0.4$     | V       | D3.17  |
| Input low voltage     | SATA_XTALI crystal mode<br>Bypass mode   | $SV_{IL}$ | —  | $V_{xtal} - 0.4 V$<br>$(V_{DD\_IO}/2) - 0.4$   | V       | D3.18  |
| Input low voltage     | USB_XTALI crystal mode<br>Bypass mode  | $UV_{IL}$ | —  | $V_{xtal} - 0.4$<br>$(V_{DD\_IO}/2) - 0.4$     | V       | D3.19  |
| Input low voltage     | RTC_XTALI crystal mode<br>Bypass mode  | $RV_{IL}$ | —  | $(VBAT\_RTC/5) - 0.5$<br>$(VBAT\_RTC/2) - 0.4$ | V       | D3.20  |
| Input leakage current | $V_{in} = 0$ or $V_{DD\_IO}/V_{DD\_MEM\_IO\_DDR/2}$ (depending on input type) <sup>5</sup> | $I_{IN}$  | -2.5   | 2.5  | $\mu A$ | D3.21  |
| Input leakage current | SYS_XTALI $V_{in} = 0$ or $V_{DD\_IO}$   | $I_{IN}$  | —  | 20   | $\mu A$ | D3.22  |

Table 6. DC Electrical Specifications (continued)

| Characteristic                                 | Condition  | Symbol       | Min                                  | Max                                  | Unit     | SpecID |
|--|--|--------------|--------------------------------------|--------------------------------------|----------|--------|
| Input leakage current                          | RTC_XTALI $V_{in} = 0$ or $V_{DD\_IO}$                           | $I_{IN}$     | —                                    | 1.0                                  | $\mu A$  | D3.23  |
| Input current, pullup resistor <sup>6</sup>    | Pullup $V_{DD\_IO}$ $V_{in} = V_{IL}$                            | $I_{INpu}$   | 25                                   | 150                                  | $\mu A$  | D3.24  |
| Input current, pulldown resistor <sup>8</sup>  | Pulldown $V_{DD\_IO}$ $V_{in} = V_{IH}$                          | $I_{INpd}$   | 25                                   | 150                                  | $\mu A$  | D3.25  |
| Output high voltage                            | IOH is driver dependent <sup>7</sup> $V_{DD\_IO}$                | $V_{OH}$     | $0.8 \times V_{DD\_IO}$              | —                                    | V        | D3.26  |
| Output high voltage                            | IOH is driver dependent <sup>7</sup><br>$V_{DD\_MEM\_IO\_DDR}$   | $V_{OHDDR}$  | 1.90                                 | —                                    | V        | D3.27  |
| Output high voltage                            | IOH is driver dependent <sup>7</sup><br>$V_{DD\_MEM\_IO\_DDR2}$  | $V_{OHDDR2}$ | 1.396                                | —                                    | V        | D3.28  |
| Output high voltage                            | IOH is driver dependent <sup>7</sup><br>$V_{DD\_MEM\_IO\_LPDDR}$ | $V_{OHLDDR}$ | $V_{DD\_MEM\_IO} - 0.28$             | —                                    | V        | D3.28  |
| Output low voltage                             | IOL is driver dependent <sup>7</sup> $V_{DD\_IO}$                | $V_{OL}$     | —                                    | $0.2 \times V_{DD\_IO}$              | V        | D3.30  |
| Output low voltage                             | IOL is driver dependent <sup>7</sup><br>$V_{DD\_MEM\_IO\_DDR}$   | $V_{OLDDR}$  | —                                    | 0.36                                 | V        | D3.31  |
| Output low voltage                             | IOL is driver dependent <sup>7</sup><br>$V_{DD\_MEM\_IO\_DDR2}$  | $V_{OLDDR2}$ | —                                    | 0.28                                 | V        | D3.32  |
| Output low voltage                             | IOL is driver dependent <sup>7</sup><br>$V_{DD\_MEM\_IO\_LPDDR}$ | $V_{OLLDDR}$ | —                                    | 0.28                                 | V        | D3.33  |
| Differential cross point voltage (DDR MCK/MCK) | —  | $V_{OXMCK}$  | $0.5 \times V_{DD\_MEM\_IO} - 0.125$ | $0.5 \times V_{DD\_MEM\_IO} + 0.125$ | V        | D3.34  |
| DC Injection Current Per Pin <sup>8</sup>      | —  | $I_{CS}$     | -1.0                                 | 1.0                                  | mA       | D3.35  |
| Input Capacitance (digital pins)               | —  | $C_{in}$     | —                                    | 7                                    | pF       | D3.36  |
| Input Capacitance (analog pins)                | —  | $C_{in}$     | —                                    | 10                                   | pF       | D3.37  |
| On Die Termination (DDR2)                      | —  | $R_{ODT}$    | 120                                  | 180                                  | $\Omega$ | D3.38  |

<sup>1</sup> This parameter is meant for those who do not use quartz crystals or resonators, but CAN osc, in crystal mode. In that case,  $V_{extal} - V_{xtal} - 400mV$  criteria has to be met for oscillator's comparator to produce output clock.

<sup>2</sup> This parameter is meant for those who do not use quartz crystals or resonators, but signal generator clock to drive, in bypass mode. In that case, drive only the EXTAL pin not connecting anything to other pin for the oscillator's comparator to produce output clock.

<sup>3</sup> This parameter is meant for those who do not use quartz crystals or resonators, but CAN osc, in crystal mode. In that case, drive one of the XTAL\_IN or XTAL\_OUT pins not connecting anything to other pin for the oscillator's comparator to produce output clock.

<sup>4</sup> This parameter is meant for those who do not use quartz crystals or resonators, but signal generator clock to drive, in bypass mode. In that case, drive only the xtal\_in pin not connecting anything to other pin for the oscillator's comparator to produce output clock.

<sup>5</sup> Leakage current is measured with output drivers disabled and pull-up/pull-downs inactive.

<sup>6</sup> Pullup current is measured at VIL and pulldown current is measured at VIH.

## Electrical and Thermal Characteristics

- <sup>7</sup> See Table 7 for the typical drive capability of a specific signal pin based on the type of output driver associated with that pin as listed in Table 3.
- <sup>8</sup> All injection current is transferred to  $V_{DD\_IO}/V_{DD\_MEM\_IO}$ . An external load is required to dissipate this current to maintain the power supply within the specified voltage range.  
Total injection current for all digital input-only and all digital input/output pins must not exceed 10 mA. Exceeding this limit can cause disruption of normal operation.

**Table 7. I/O Pads—Drive Current, Slew Rate**

| Pad Type   | Supply Voltage                   | Drive Select/Slew Rate Control | Rise time max (ns) | Fall time max (ns) | Current Ioh (mA) | Current Iol (mA) | SpecID |
|------------|----------------------------------|--------------------------------|--------------------|--------------------|------------------|------------------|--------|
| General IO | $V_{DD\_IO} = 3.3V$              | configuration 3 (11)           | 1.4                | 1.6                | 35               | 35               | D3.41  |
|            |                                  | configuration 2 (10)           | 9.8                | 12                 |                  |                  | D3.42  |
|            |                                  | configuration 1 (01)           | 19                 | 24                 |                  |                  | D3.43  |
|            |                                  | configuration 0 (00)           | 140                | 183                |                  |                  | D3.44  |
| DDR        | $V_{DD\_MEM\_IO} = 2.5V$ (DDR)   | configuration 3 (011)          | 2                  | 2                  | 16.2             | 16.2             | D3.45  |
|            | $V_{DD\_MEM\_IO} = 1.8V$ (LPDDR) | configuration 0 (000)          | 1                  | 1                  | 4.6              | 4.6              | D3.46  |
|            |                                  | configuration 1 (001)          |                    |                    | 8.1              | 8.1              | D3.47  |
|            | $V_{DD\_MEM\_IO} = 1.8V$ (DDR2)  | configuration 2 (010)          | 1                  | 1                  | 5.3              | 5.3              | D3.48  |
|            |                                  | configuration 6 (110)          |                    |                    | 13.4             | 13.4             | D3.49  |
| PCI        | $V_{DD\_IO} = 3.3V$              | configuration 1 (1)            | 1.4                | 1.4                | 11               | 17               | D3.50  |
|            |                                  | configuration 0 (0)            | 2                  | 2                  |                  |                  | D3.51  |

Notes:

- General IO – Rise and Fall Times at Drive load 50pF.
- PCI – Rise and Fall Times at Drive load 10pF.
- DDR – for LPDDR/Mobile-DDR, slew rate is measured between 20% of  $V_{DD\_MEM\_IO}$  and 80% of  $V_{DD\_MEM\_IO}$ .
- DDR – for DDR, DDR2, rising signals, slew rate is measured between  $V_{DD\_MEM\_IO} \times 0.5$  and  $V_{IH\_AC}$ . For falling signals, slew rate is measured between  $V_{DD\_MEM\_IO} \times 0.5$  and  $V_{IL\_AC}$ .
- DDR – Rise and Fall Times terminated at the destination with 50 ohm to MVTT ( $0.5 \times V_{DD\_MEM\_IO}$ ), with 4 pF representing the DDR input capacitance.

### 3.1.4 Electrostatic Discharge

#### CAUTION

This device contains circuitry that protects against damage due to high-static voltage or electrical fields. However, it is advised that normal precautions be taken to avoid application of any voltages higher than maximum-rated voltages. Operational reliability is enhanced if unused inputs are tied to an appropriate logic voltage level (GND or VDD). Table 10 gives package thermal characteristics for this device.

**Table 8. ESD and Latch-Up Protection Characteristics**

| Symbol           | Rating  | Min  | Max | Unit | SpecID |
|------------------|---|------|-----|------|--------|
| V <sub>HBM</sub> | Human Body Model (HBM) – JEDEC JESD22-A114-B  | 2000 | —   | V    | D4.1   |
| V <sub>MM</sub>  | Machine Model (MM) – JEDEC JESD22-A115        | 200  | —   | V    | D4.2   |
| V <sub>CDM</sub> | Charge Device Model (CDM) – JEDEC JESD22-C101 | 500  | —   | V    | D4.3   |

### 3.1.5 Power Dissipation

Power dissipation of the MPC5121e/MPC5123 is caused by 4 different components: the dissipation of the internal or core digital logic (supplied by V<sub>DD\_CORE</sub>), the dissipation of the analog circuitry (supplied by SYS\_PLL\_AVDD and CORE\_PLL\_AVDD), the dissipation of the IO logic (supplied by V<sub>DD\_MEM\_IO</sub> and V<sub>DD\_IO</sub>) and the dissipation of the PHYs (supplied by own supplies). Table 9 details typical measured core and analog power dissipation figures for a range of operating modes. However, the dissipation due to the switching of the IO pins can not be given in general, but must be calculated for each application case using the following formula:

$$P_{IO} = P_{IOint} + \sum_M N \times C \times V_{DD\_IO}^2 \times f \quad \text{Eqn. 1}$$

where N is the number of output pins switching in a group M, C is the capacitance per pin, V<sub>DD\_IO</sub> is the IO voltage swing, f is the switching frequency and P<sub>IOint</sub> is the power consumed by the unloaded IO stage. The total power consumption of the device must not exceed the value that would cause the maximum junction temperature to be exceeded.

$$P_{total} = P_{core} + P_{analog} + P_{IO} + P_{PHYS} \quad \text{Eqn. 2}$$

**Table 9. Power Dissipation**

| Core Power Supply (V <sub>DD_CORE</sub> )                                  |   |      | SpecID |
|--|---|------|--------|
| Mode   | High-Performance<br>e300 = 300 MHz, CSB = 200 MHz | Unit |        |
| Operational <sup>1</sup>   | 800   | mW   | D5.1   |
| Deep-Sleep <sup>1</sup>  | 1   | mW   | D5.2   |
| Hibernation  | 20  | uW   | D5.3   |
| PLL/OSC Power Supplies (SYS_PLL_AVDD, CORE_PLL_AVDD)                       |   |      |        |
| Typical  | 25  | mW   | D5.4   |
| Unloaded I/O Power Supplies (V <sub>DD_IO</sub> , V <sub>DD_MEM_IO</sub> ) |   |      |        |

**Table 9. Power Dissipation (continued)**

| Core Power Supply ( $V_{DD\_CORE}$ )     |                               |      | SpecID |
|--|-------------------------------|------|--------|
| Mode                                     | High-Performance              | Unit |        |
|  | e300 = 300 MHz, CSB = 200 MHz |      |        |
| Typical                                  | 300                           | mW   | D5.5   |
| PHY Power Supplies (USB_VDDA, SATA_VDDA) |                               |      |        |
| Typical                                  | 200                           | mW   | D5.6   |

<sup>1</sup> Typical core power is measured at  $V_{DD\_CORE} = 1.4\text{ V}$ ,  $T_j = 25\text{ }^\circ\text{C}$ .

**NOTE**

The maximum power depends on the supply voltage, process corner, junction temperature, and the concrete application and clock configurations.

The worst case power consumption could reach a maximum of 2000 mW.

### 3.1.6 Thermal Characteristics

**Table 10. Thermal Resistance Data**

| Rating  | Board Layers            | Symbol           | TEPBGA | TEPBGA<br>2 | Value | Unit               | SpecID |
|---|-------------------------|------------------|--------|-------------|-------|--------------------|--------|
| Junction to Ambient Natural Convection <sup>1,2</sup> | Single layer board (1s) | $R_{\theta JA}$  | 31     | 24          | 30    | $^\circ\text{C/W}$ | D6.1   |
| Junction to Ambient Natural Convection <sup>1,3</sup> | Four layer board (2s2p) | $R_{\theta JMA}$ | 22     | 17          | 22    | $^\circ\text{C/W}$ | D6.2   |
| Junction to Ambient (@200 ft/min) <sup>1,3</sup>      | Single layer board (1s) | $R_{\theta JMA}$ | 25     | 19          | 24    | $^\circ\text{C/W}$ | D6.3   |
| Junction to Ambient (@200 ft/min) <sup>1,3</sup>      | Four layer board (2s2p) | $R_{\theta JMA}$ | 19     | 14          | 19    | $^\circ\text{C/W}$ | D6.4   |
| Junction to Board <sup>4</sup>                        | —                       | $R_{\theta JB}$  | 14     | 9           | 14    | $^\circ\text{C/W}$ | D6.5   |
| Junction to Case <sup>5</sup>                         | —                       | $R_{\theta JC}$  | 9      | 7           | 8     | $^\circ\text{C/W}$ | D6.6   |
| Junction to Package Top <sup>6</sup>                  | Natural Convection      | $\Psi_{JT}$      | 2      | 7           | 2     | $^\circ\text{C/W}$ | D6.7   |

<sup>1</sup> Junction temperature is a function of die size, on-chip power dissipation, package thermal resistance, mounting site (board) temperature, ambient temperature, air flow, power dissipation of other components on the board, and board thermal resistance.

<sup>2</sup> Per SEMI G38-87 and JEDEC JESD51-2 with the single layer board horizontal.

<sup>3</sup> Per JEDEC JESD51-6 with the board horizontal.

<sup>4</sup> Thermal resistance between the die and the printed circuit board per JEDEC JESD51-8. Board temperature is measured on the top surface of the board near the package.

<sup>5</sup> Thermal resistance between the die and the case top surface as measured by the cold plate method (MIL SPEC-883 Method 1012.1).

<sup>6</sup> Thermal characterization parameter indicating the temperature difference between package top and the junction temperature per JEDEC JESD51-2. When Greek letters are not available, the thermal characterization parameter is written as Psi-JT.



### 3.1.6.1 Heat Dissipation

An estimation of the chip-junction temperature,  $T_J$ , can be obtained from the following equation:

$$T_J = T_A + (R_{\theta JA} \times P_D) \quad \text{Eqn. 3}$$

where:

- $T_A$  = ambient temperature for the package ( $^{\circ}\text{C}$ )
- $R_{\theta JA}$  = junction to ambient thermal resistance ( $^{\circ}\text{C}/\text{W}$ )
- $P_D$  = power dissipation in package (W)

The junction to ambient thermal resistance is an industry standard value, which provides a quick and easy estimation of thermal performance. Unfortunately, there are two values in common usage: the value determined on a single layer board, and the value obtained on a board with two planes. For packages such as the PBGA, these values can be different by a factor of two. Which value is correct depends on the power dissipated by other components on the board. The value obtained on a single layer board is appropriate for the tightly packed printed circuit board. The value obtained on the board with the internal planes is usually appropriate if the board has low power dissipation and the components are well separated.

Historically, the thermal resistance has frequently been expressed as the sum of a junction to case thermal resistance and a case to ambient thermal resistance:

$$R_{\theta JA} = R_{\theta JC} + R_{\theta CA} \quad \text{Eqn. 4}$$

where:

- $R_{\theta JA}$  = junction to ambient thermal resistance ( $^{\circ}\text{C}/\text{W}$ )
- $R_{\theta JC}$  = junction to case thermal resistance ( $^{\circ}\text{C}/\text{W}$ )
- $R_{\theta CA}$  = case to ambient thermal resistance ( $^{\circ}\text{C}/\text{W}$ )

$R_{\theta JC}$  is device related and cannot be influenced by the user. You control the thermal environment to change the case to ambient thermal resistance,  $R_{\theta CA}$ . For instance, you can change the air flow around the device, add a heat sink, change the mounting arrangement on printed circuit board, or change the thermal dissipation on the printed circuit board surrounding the device. This description is most useful for ceramic packages with heat sinks where some 90% of the heat flow is through the case to the heat sink to ambient. For most packages, a better model is required.

A more accurate thermal model can be constructed from the junction to board thermal resistance and the junction to case thermal resistance. The junction to case covers the situation where a heat sink is used or where a substantial amount of heat is dissipated from the top of the package. The junction to board thermal resistance describes the thermal performance when most of the heat is conducted to the printed circuit board. This model can be used for hand estimations or for a computational fluid dynamics (CFD) thermal model.

To determine the junction temperature of the device in the application after prototypes are available, the Thermal Characterization Parameter ( $\Psi_{JT}$ ) can be used to determine the junction temperature with a measurement of the temperature at the top center of the package case using the following equation:

$$T_J = T_T + (\Psi_{JT} \times P_D) \quad \text{Eqn. 5}$$

where:

- $T_T$  = thermocouple temperature on top of package ( $^{\circ}\text{C}$ )
- $\Psi_{JT}$  = thermal characterization parameter ( $^{\circ}\text{C}/\text{W}$ )
- $P_D$  = power dissipation in package (W)

The thermal characterization parameter is measured per JESD51-2 specification using a 40-gauge type T thermocouple epoxied to the top center of the package case. The thermocouple should be positioned, so that the thermocouple junction rests on the package. A small amount of epoxy is placed over the thermocouple junction and over approximately one mm of wire extending

## Electrical and Thermal Characteristics

from the junction. The thermocouple wire is placed flat against the package case to avoid measurement errors caused by cooling effects of the thermocouple wire.

### 3.2 Oscillator and PLL Electrical Characteristics

The MPC5121e/MPC5123 System requires a system-level clock input SYS\_XTALI. This clock input may be driven directly from an external oscillator or with a crystal using the internal oscillator.

There is a separate oscillator for the independent Real Time Clock (RTC) system.

The MPC5121e/MPC5123 clock generation uses two phase locked loop (PLL) blocks.

- The system PLL (SYS\_PLL) takes an external reference frequency and generates the internal system clock. The system clock frequency is determined by the external reference frequency and the settings of the SYS\_PLL configuration.
- The e300 core PLL (CORE\_PLL) generates a master clock for all of the CPU circuitry. The e300 core clock frequency is determined by the system clock frequency and the settings of the CORE\_PLL configuration.

The USB PHY contains its own oscillator with the input USB\_XTALI and an embedded PLL.

The SATA PHY contains its own oscillator with the input SATA\_XTALI and an embedded PLL.

#### 3.2.1 System Oscillator Electrical Characteristics

**Table 11. System Oscillator Electrical Characteristics**

| Characteristic      | Symbol                 | Min  | Typical | Max  | Unit | SpecID |
|---------------------|------------------------|------|---------|------|------|--------|
| SYS_XTALI frequency | $f_{\text{sys\_xtal}}$ | 15.6 | 33.3    | 35.0 | MHz  | O1.1   |

The system oscillator can work in oscillator mode or in bypass mode to support an external input clock as clock reference.

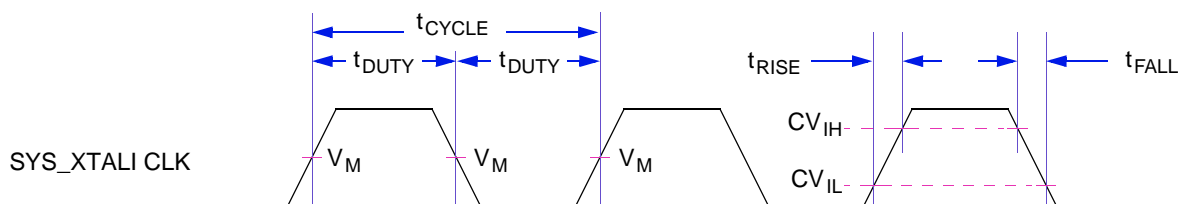

**Figure 3. Timing Diagram—SYS\_XTALI**

**Table 12. SYS\_XTALI Timing**

| Sym                | Description                          | Min  | Max   | Units | SpecID |
|--------------------|--------------------------------------|------|-------|-------|--------|
| $t_{\text{CYCLE}}$ | SYS_XTALI cycle time <sup>1, 2</sup> | 64.1 | 28.57 | ns    | O.1.2  |
| $t_{\text{RISE}}$  | SYS_XTALI rise time <sup>3</sup>     | 1    | 4     | ns    | O.1.3  |
| $t_{\text{FALL}}$  | SYS_XTALI fall time <sup>4</sup>     | 1    | 4     | ns    | O.1.4  |
| $t_{\text{DUTY}}$  | SYS_XTALI duty cycle <sup>5</sup>    | 40   | 60    | %     | O.1.5  |

<sup>1</sup> The SYS\_XTALI frequency and system PLL settings must be chosen such that the resulting system frequencies do not exceed their respective maximum or minimum operating frequencies. See the *MPC5121e Microcontroller Reference Manual*.

<sup>2</sup> The MIN/Max cycle times are calculated using  $1/f_{\text{sys\_xtal}}$  (MIN/MAX) where the  $f_{\text{sys\_xtal}}$  (MIN/MAX) (15.6/35 MHz) are taken from [Table 11](#).

<sup>3</sup> Rise time is measured from 20% of vdd to 80% of  $V_{DD}$ .

<sup>4</sup> Fall time is measured from 20% of vdd to 80% of  $V_{DD}$ .

<sup>5</sup> SYS\_XTALI duty cycle is measured at  $V_M$ .

### 3.2.2 RTC Oscillator Electrical Characteristics

Table 13. RTC Oscillator Electrical Characteristics

| Characteristic      | Symbol          | Min | Typical | Max | Unit | SpecID |
|---------------------|-----------------|-----|---------|-----|------|--------|
| RTC_XTALI frequency | $f_{rtc\_xtal}$ | —   | 32.768  | —   | kHz  | O2.1   |

### 3.2.3 System PLL Electrical Characteristics

Table 14. System PLL Specifications

| Characteristic                                       | Symbol            | Min | Typical | Max | Unit    | SpecID |
|--|-------------------|-----|---------|-----|---------|--------|
| Sys PLL input clock frequency <sup>1</sup>           | $f_{sys\_xtal}$   | 16  | 33.3    | 67  | MHz     | O3.1   |
| Sys PLL input clock jitter <sup>2</sup>              | $t_{jitter}$      | —   | —       | 10  | ps      | O3.2   |
| Sys PLL VCO frequency <sup>1</sup>                   | $f_{VCOsys}$      | 400 | —       | 800 | MHz     | O3.3   |
| Sys PLL VCO output jitter (Dj), peak to peak / cycle | $f_{VCOjitterDj}$ | —   | —       | 40  | ps      | O3.4   |
| Sys PLL VCO output jitter (Rj), RMS 1 sigma          | $f_{VCOjitterRj}$ | —   | —       | 12  | ps      | O3.5   |
| Sys PLL relock time—after power up <sup>3</sup>      | $t_{lock1}$       | —   | —       | 200 | $\mu$ s | O3.6   |
| Sys PLL relock time—when power was on <sup>4</sup>   | $t_{lock2}$       | —   | —       | 170 | $\mu$ s | O3.7   |

<sup>1</sup> The SYS\_XTALI frequency and PLL Configuration bits must be chosen such that the resulting system frequency, CPU (core) frequency, and PLL (VCO) frequency do not exceed their respective maximum or minimum operating frequencies.

<sup>2</sup> This represents total input jitter—short term and long term combined. Two different types of jitter can exist on the input to CORE\_SYSCLK, systemic and true random jitter. True random jitter is rejected. Systemic jitter is passed into and through the PLL to the internal clock circuitry.

<sup>3</sup> PLL relock time is the maximum amount of time required for the PLL lock after a stable VDD and CORE\_SYSCLK are reached during the power-on reset sequence.

<sup>4</sup> PLL relock time is the maximum amount of time required for the PLL lock after the PLL has been disabled and subsequently re-enabled during sleep modes.

### 3.2.4 e300 Core PLL Electrical Characteristics

The internal clocking of the e300 core is generated from and synchronized to the system clock by means of a voltage-controlled core PLL.

Table 15. e300 PLL Specifications

| Characteristic                      | Symbol         | Min | Typical | Max | Unit    | SpecID |
|-------------------------------------|----------------|-----|---------|-----|---------|--------|
| e300 frequency <sup>1</sup>         | $f_{core}$     | 200 | —       | 400 | MHz     | O4.1   |
| e300 PLL VCO frequency <sup>1</sup> | $f_{VCOcore}$  | 400 | —       | 800 | MHz     | O4.3   |
| e300 PLL input clock frequency      | $f_{CSB\_CLK}$ | 50  | —       | 200 | MHz     | O4.4   |
| e300 PLL input clock cycle time     | $t_{CSB\_CLK}$ | 5   | —       | 20  | ns      | O4.5   |
| e300 PLL relock time <sup>2</sup>   | $t_{lock}$     | —   | —       | 200 | $\mu$ s | O4.6   |

## Electrical and Thermal Characteristics

- <sup>1</sup> The frequency and e300 PLL Configuration bits must be chosen such that the resulting system frequencies, CPU (core) frequency, and e300 PLL (VCO) frequency do not exceed their respective maximum or minimum operating frequencies in [Table 16](#). There is a hard coded relationship between  $f_{\text{core}}$  and  $f_{\text{VCOcore}}$  ( $f_{\text{core}} = f_{\text{VCOcore}}/2$ ).
- <sup>2</sup> PLL relock time is the maximum amount of time required for the PLL lock after a stable VDD and CORE\_SYSCLK are reached during the power-on reset sequence. This specification also applies when the PLL has been disabled and subsequently re-enabled during sleep modes.

## 3.3 AC Electrical Characteristics

### 3.3.1 Overview

Hyperlinks to the indicated timing specification sections are provided in the following:

- [AC Operating Frequency Data](#)
- [SDHC](#)
- [Resets](#)
- [DIU](#)
- [External Interrupts](#)
- [SPDIF](#)
- [SDRAM \(DDR\)](#)
- [CAN](#)
- [PCI](#)
- [I<sup>2</sup>C](#)
- [LPC](#)
- [J1850](#)
- [NFC](#)
- [PSC](#)
- [PATA](#)
- [GPIOs and Timers](#)
- [SATA PHY](#)
- [Fusebox](#)
- [FEC](#)
- [IEEE 1149.1 \(JTAG\)](#)
- [USB ULPI](#)
- [VIU](#)
- [On-Chip USB PHY](#)

AC Test Timing Conditions:

Unless otherwise noted, all test conditions are as follows:

- $T_A = -40$  to  $85$  °C
- $V_{DD\_CORE} = 1.33$  to  $1.47$  V  
 $V_{DD\_IO} = 3.0$  to  $3.6$  V
- Input conditions:  
All Inputs:  $t_r, t_f \leq 1$  ns
- Output Loading:  
All Outputs:  $50$  pF

### 3.3.2 AC Operating Frequency Data

Table 16 provides the operating frequency information for the MPC5121e/MPC5123.

**Table 16. Clock Frequencies**

|                     | Min  | Max | Units | SpecID |
|---------------------|------|-----|-------|--------|
| e300 Processor Core | 200  | 400 | MHz   | A1.1   |
| SDRAM Clock         | 28.6 | 200 | MHz   | A1.2   |
| CSB Bus Clock       | 50.0 | 200 | MHz   | A1.3   |
| IP Bus Clock        | 8.3  | 83  | MHz   | A1.4   |
| PCI Clock           | 4.43 | 66  | MHz   | A1.5   |
| LPC Clock           | 2.08 | 83  | MHz   | A1.6   |

**Table 16. Clock Frequencies (continued)**

|            | Min  | Max  | Units | SpecID |
|------------|------|------|-------|--------|
| NFC Clock  | 2.08 | 83   | MHz   | A1.7   |
| DIU Clock  | 0.78 | 100  | MHz   | A1.8   |
| SDHC Clock | 0.78 | 66.6 | MHz   | A1.9   |
| MBX Clock  | 6.25 | 100  | MHz   | A1.10  |

NOTES:

1. The SYS\_XTALI frequency, Sys PLL, and CORE PLL settings must be chosen so that the resulting e300 clk, csb\_clk, MCK, frequencies do not exceed their respective maximum or minimum operating frequencies.
2. The values are valid for the user operation mode. There can be deviations for test modes.
3. The selection of the peripheral clock frequencies needs to take care about requirements for baud rates and minimum frequency limitation.
4. The DDR data rate is 2x the DDR memory bus frequency.

See the *MPC5121e Microcontroller Reference Manual* for more information on the clock subsystem.

### 3.3.3 Resets

The MPC5121e/MPC5123 has three reset pins:

- $\overline{\text{PORESET}}$ —Power on Reset
- $\overline{\text{HRESET}}$ —Hard Reset
- $\overline{\text{SRESET}}$ —Software Reset

These signals are asynchronous I/O signals and can be asserted at any time. The input side uses a Schmitt trigger and requires the same input characteristics as other MPC5121e/MPC5123 inputs, as specified in [Section 3.1, “DC Electrical Characteristics.”](#)

As long as  $V_{DD}$  is not stable the  $\overline{\text{HRESET}}$  output is not stable.

**Table 17. Reset Rise / Fall Timing**

| Description   | Min | Max | Unit | SpecID |
|---|-----|-----|------|--------|
| $\overline{\text{PORESET}}$ <sup>1</sup> fall time  | —   | 1   | ms   | A3.4   |
| $\overline{\text{PORESET}}$ rise time               | —   | 1   | ms   | A3.5   |
| $\overline{\text{HRESET}}$ <sup>2,3</sup> fall time | —   | 1   | ms   | A3.6   |
| $\overline{\text{HRESET}}$ rise time                | —   | 1   | ms   | A3.7   |
| $\overline{\text{SRESET}}$ fall time                | —   | 1   | ms   | A3.8   |
| $\overline{\text{SRESET}}$ rise time                | —   | 1   | ms   | A3.9   |

<sup>1</sup> Make sure that the  $\overline{\text{PORESET}}$  does not carry any glitches. The MPC5121e/MPC5123 has no filter to prevent them from getting into the chip.

<sup>2</sup>  $\overline{\text{HRESET}}$  and  $\overline{\text{SRESET}}$  must have a monotonous rise time.

<sup>3</sup> The assertion of  $\overline{\text{HRESET}}$  becomes active at Power on Reset without any SYS\_XTALI clock.

The timing relationship is shown in [Figure 4](#).

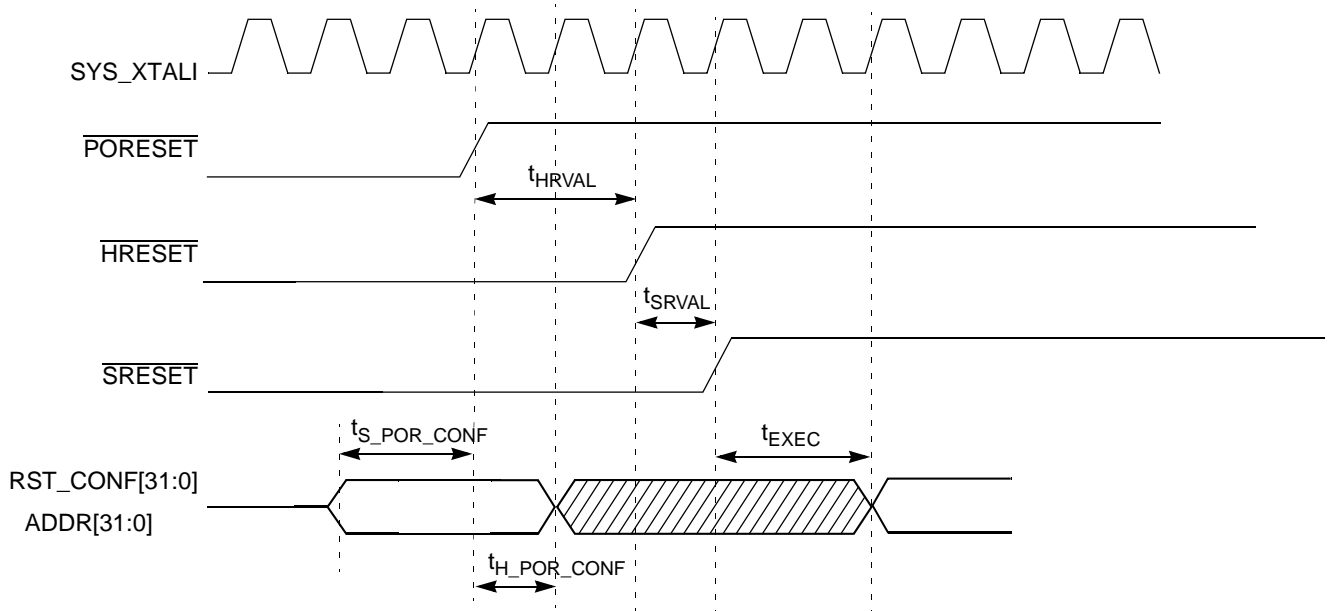

Figure 4. Power-Up Behavior

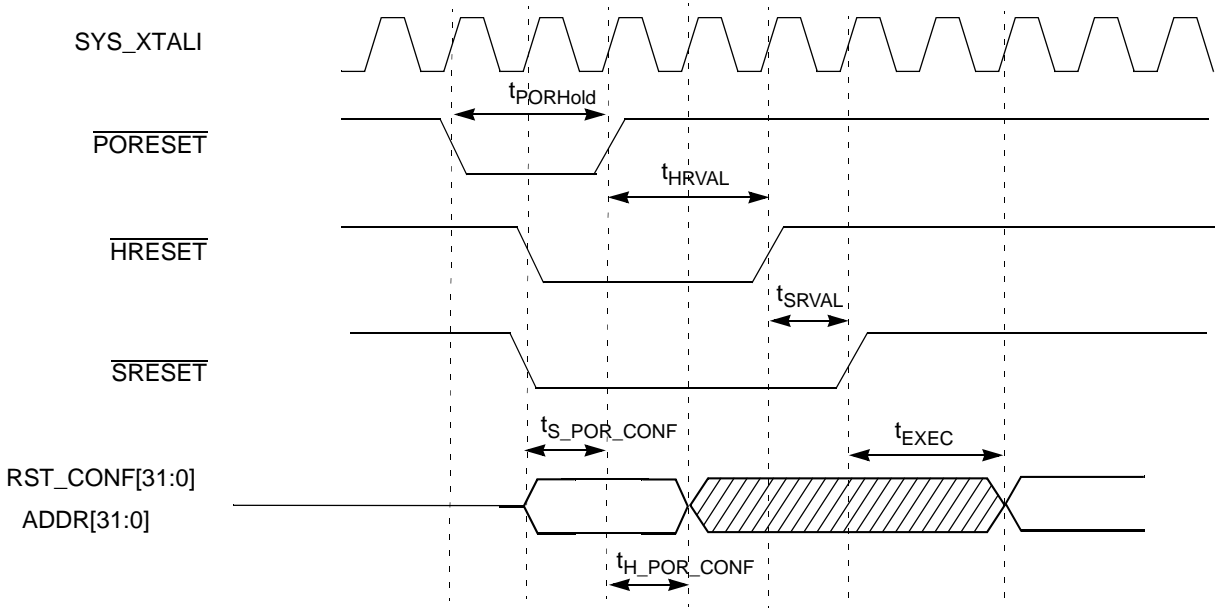

Figure 5. Power-On Reset Behavior

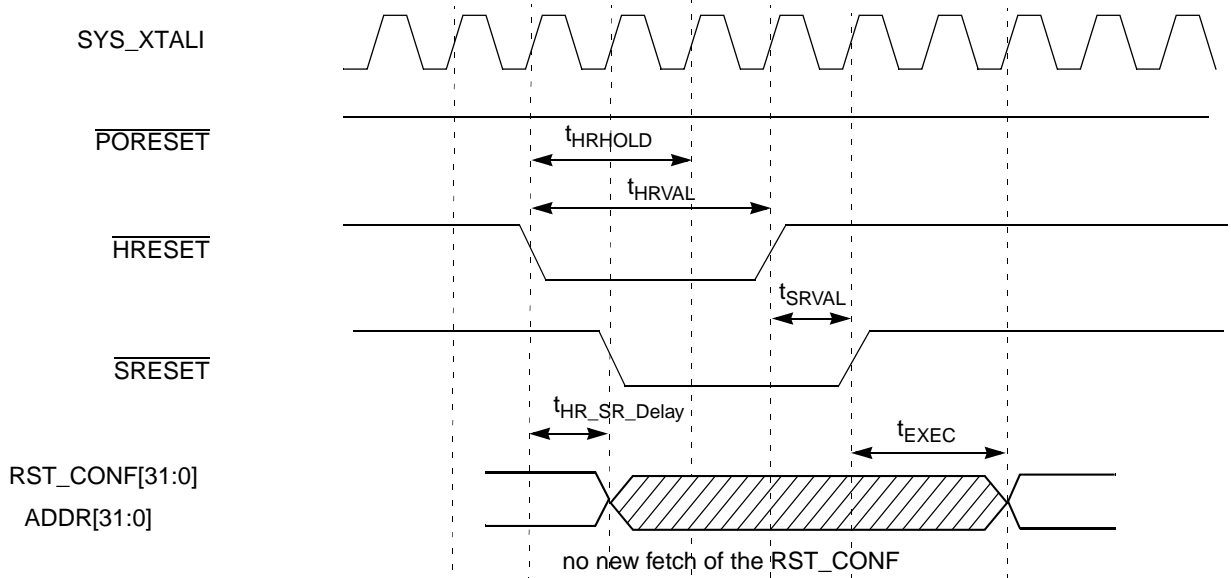

Figure 6. HRESET Behavior

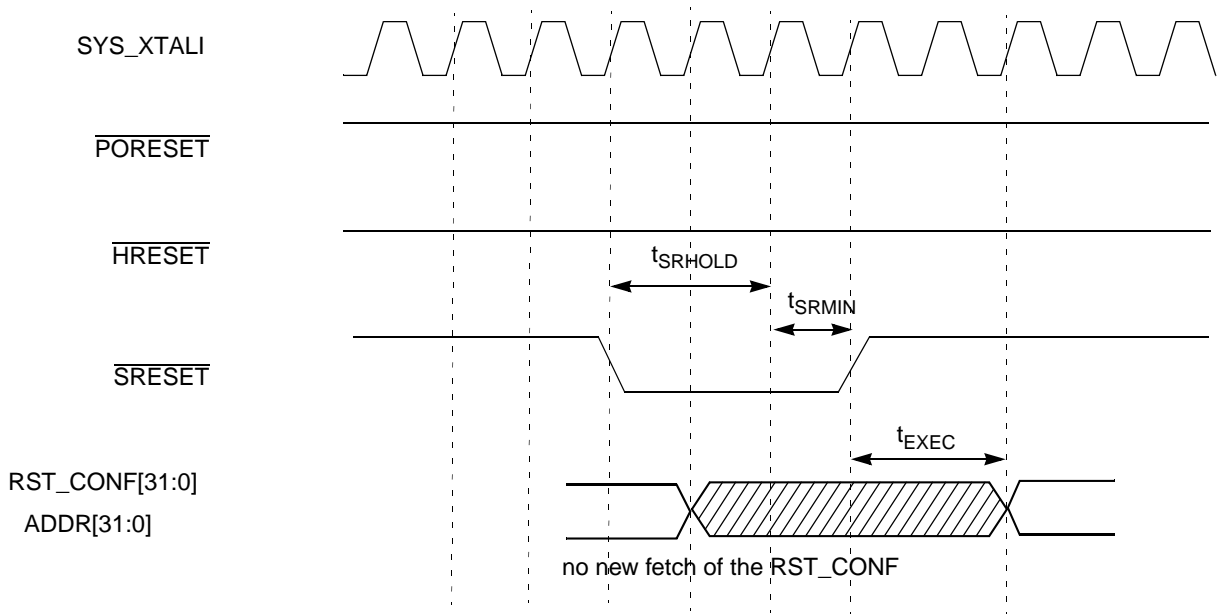

Figure 7. SRESET Behavior

Table 18. Reset Timing

| Symbol        | Description   | Value<br>SYS_XTALI | SpecID |
|---------------|---|--------------------|--------|
| $t_{PORHOLD}$ | Time $\overline{PORESET}$ must be held low before a qualified reset occurs  | 4 cycles           | A3.10  |
| $t_{HRVAL}$   | Time $\overline{HRESET}$ is asserted after a qualified reset occurs         | 26810 cycles       | A3.11  |
| $t_{SRVAL}$   | Time $\overline{SRESET}$ is asserted after assertion of $\overline{HRESET}$ | 32 cycles          | A3.12  |
| $t_{EXEC}$    | Time between $\overline{SRESET}$ assertion and first core instruction fetch | 4 cycles           | A3.13  |



**Table 18. Reset Timing (continued)**

| Symbol                   | Description  | Value<br>SYS_XTALI | SpecID |
|--------------------------|--|--------------------|--------|
| t <sub>S_POR_CONF</sub>  | Reset configuration setup time before assertion of $\overline{\text{PORESET}}$   | 1 cycle            | A3.14  |
| t <sub>H_POR_CONF</sub>  | Reset configuration hold time after assertion of $\overline{\text{PORESET}}$     | 1 cycle            | A3.15  |
| t <sub>HR_SR_DELAY</sub> | Time from falling edge of HRESET to falling edge of SRESET                       | 4 cycles           | A3.16  |
| t <sub>HRHOLD</sub>      | Time $\overline{\text{HRESET}}$ must be held low before a qualified reset occurs | 4 cycles           | A3.17  |
| t <sub>SRHOLD</sub>      | Time $\overline{\text{SRESET}}$ must be held low before a qualified reset occurs | 4 cycles           | A3.18  |
| t <sub>SRMIN</sub>       | Time $\overline{\text{SRESET}}$ is asserted after it has been qualified          | 1 cycles           | A3.19  |

### 3.3.4 External Interrupts

The MPC5121e/MPC5123 provides three different kinds of external interrupts:

- IRQ interrupts
- GPIO interrupts with simple interrupt capability (not available in power-down mode)
- WakeUp interrupts

**Table 19. IPIC Input AC Timing Specifications<sup>1</sup>**

| Description                     | Symbol              | Min | Unit | SpecID |
|---------------------------------|---------------------|-----|------|--------|
| IPIC inputs—minimum pulse width | t <sub>PICWID</sub> | 2T  | ns   | A4.1   |

<sup>1</sup> T is the IP bus clock cycle. T = 12 ns is the minimum value (for the maximum IP bus frequency of 83 MHz).

IPIC inputs must be valid for at least t<sub>PICWID</sub> to ensure proper operation in edge triggered mode.

### 3.3.5 SDRAM (DDR)

The MPC5121e/MPC5123 memory controller supports three types of DDR devices:

- DDR-1 (SSTL\_2 class II interface)
- DDR-2 (SSTL\_18 interface)
- LPDDR/Mobile-DDR (1.8V I/O supply voltage)

JEDEC standards define the minimum set of requirements for compliant memory devices:

- JEDEC STANDARD, DDR2 SDRAM SPECIFICATION, JESD79-2C, May 2006
- JEDEC STANDARD, Double Data Rate (DDR) SDRAM Specification, JESD79E, May 2005
- JEDEC STANDARD, Low Power Double Data Rate (LPDDR) SDRAM Specification, JESD79-4, May 2006

The MPC5121e/MPC5123 supports the configuration of two output drive strengths for DDR2 and LPDDR:

- Full drive strength
- Half drive strength (intended for lighter loads or point-to-point environments)

The MPC5121e/MPC5123 memory controller supports dynamic on-die termination in the host device and in the DDR2 memory device.

This section includes AC specifications for all DDR SDRAM pins. The DC parameters are specified in the DC Electrical Characteristics.

### 3.3.5.1 DDR and DDR2 SDRAM AC Timing Specifications

Table 20. DDR and DDR2 (DDR2-400) SDRAM Timing Specifications

At recommended operating conditions with  $V_{DD\_MEM\_IO}$  of  $\pm 5\%$

| Parameter   | Symbol          | Min                 | Max                | Unit     | Notes                | SpecID |
|---|-----------------|---------------------|--------------------|----------|----------------------|--------|
| Clock cycle time, CL=x  | $t_{CK}$        | 5000                | —                  | ps       |                      | A5.1   |
| CK HIGH pulse width   | $t_{CH}$        | 0.47                | 0.53               | $t_{CK}$ | <sup>1,2</sup>       | A5.3   |
| CK LOW pulse width  | $t_{CL}$        | 0.47                | 0.53               | $t_{CK}$ | <sup>1,2</sup>       | A5.4   |
| Skew between MCK and DQS transitions                              | $t_{DQSS}$      | -0.25               | 0.25               | $t_{CK}$ | <sup>2,3</sup>       | A5.5   |
| Address and control output setup time relative to MCK rising edge | $t_{OS(base)}$  | $(t_{CK}/2 - 750)$  | —                  | ps       | <sup>2,3</sup>       | A5.6   |
| Address and control output hold time relative to MCK rising edge  | $t_{OH(base)}$  | $(t_{CK}/2 - 750)$  | —                  | ps       | <sup>2,3</sup>       | A5.7   |
| DQ and DM output setup time relative to DQS                       | $t_{DS1(base)}$ | $(t_{CK}/4 - 500)$  | —                  | ps       | <sup>2,3</sup>       | A5.8   |
| DQ and DM output hold time relative to DQS                        | $t_{DH1(base)}$ | $(t_{CK}/4 - 500)$  | —                  | ps       | <sup>2,3</sup>       | A5.9   |
| DQS-DQ skew for DQS and associated DQ inputs                      | $t_{DQSQ}$      | $-(t_{CK}/4 - 600)$ | $(t_{CK}/4 - 600)$ | ps       | <sup>2</sup>         | A5.10  |
| DQS window start position related to CAS read command             | $t_{DQSEN}$     | TBD                 | TBD                | ps       | <sup>1,2,3,4,5</sup> | A5.11  |

- <sup>1</sup> Measured with clock pin loaded with differential 100 termination resistor.
- <sup>2</sup> All transitions measured at mid-supply ( $V_{DD\_MEM\_IO}/2$ ).
- <sup>3</sup> Measured with all outputs except the clock loaded with 50  $\Omega$  termination resistor to  $V_{DD\_MEM\_IO}/2$ .
- <sup>4</sup> In this window, the first rising edge of DQS should occur. From the start of the window to DQS rising edge, DQS should be low.
- <sup>5</sup> Window position is given for  $t_{DQSEN} = 2.0 t_{CK}$ . For other values of  $t_{DQSEN}$ , window position is shifted accordingly.

Figure 8 shows the DDR SDRAM write timing.

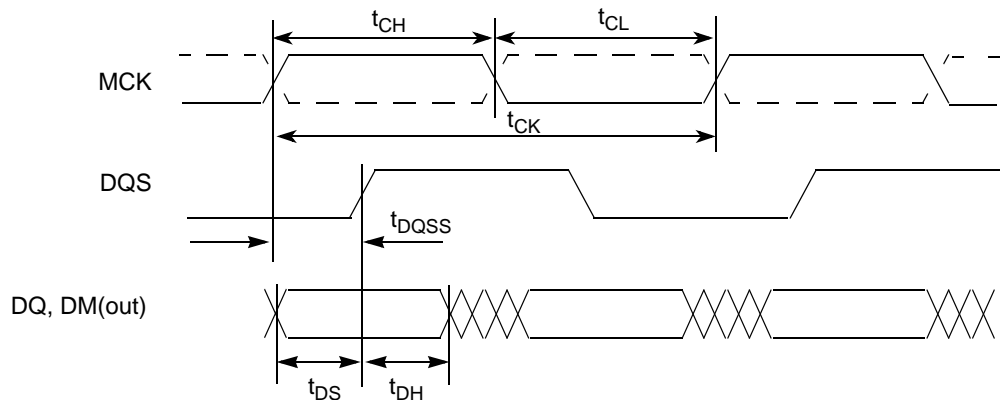

Figure 8. DDR Write Timing

Figure 9 and Figure 10 shows the DDR SDRAM read timing.

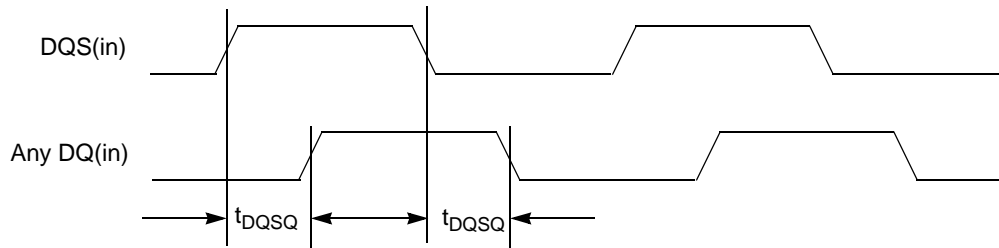

Figure 9. DDR Read Timing, DQ vs DQS

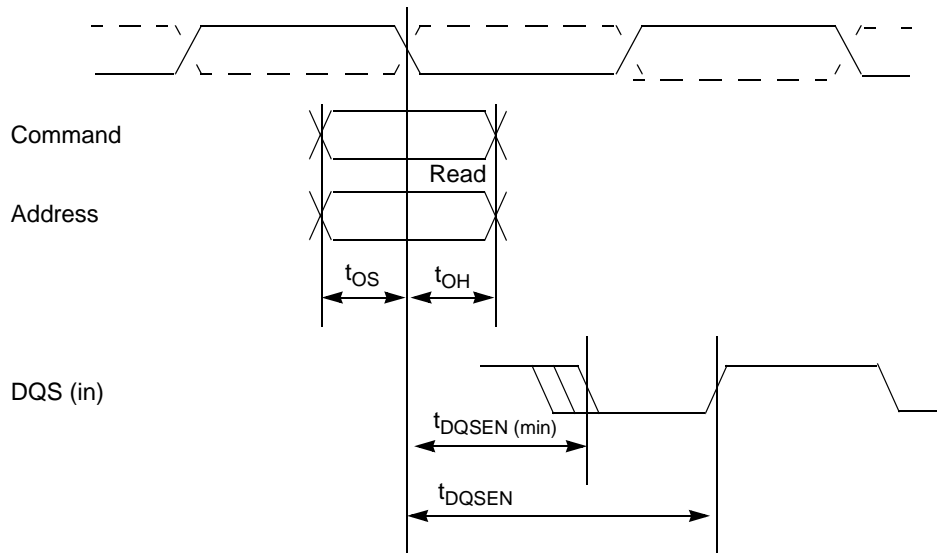

Figure 10. DDR Read Timing, DQSEN

Figure 11 provides the AC test load for the DDR bus.

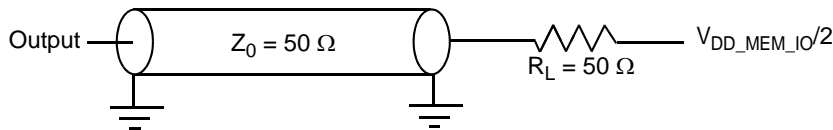

Figure 11. DDR AC Test Load

### 3.3.6 PCI

The PCI interface on the MPC5121e/MPC5123 is designed to PCI Version 2.3 and supports 33 and 66 MHz PCI operations. See the PCI Local Bus Specification; the component section specifies the electrical and timing parameters for PCI components with the intent that components connect directly together whether on the planar or an expansion board, without any external buffers or other glue logic. Parameters apply at the package pins, not at expansion board edge connectors.

The PCI\_CLK is used as output clock, the MPC5121e/MPC5123 is a PCI host device only.

Figure 12 shows the clock waveform and required measurement points for 3.3 V signaling environments. Table 21 summarizes the clock specifications.

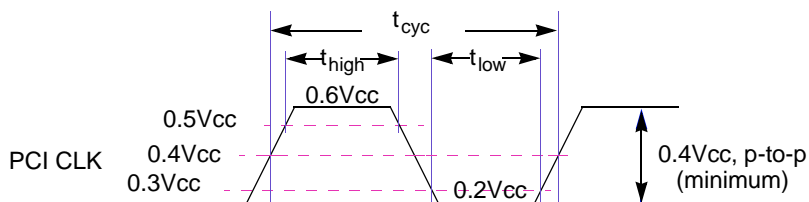

Figure 12. PCI CLK Waveform

Table 21. PCI CLK Specifications

| Sym               | Description                       | 66 MHz <sup>1</sup> |     | 33 MHz |     | Units | SpecID |
|-------------------|-----------------------------------|---------------------|-----|--------|-----|-------|--------|
|                   |                                   | Min <sup>2</sup>    | Max | Min    | Max |       |        |
| t <sub>cyc</sub>  | PCI CLK Cycle Time <sup>1,3</sup> | 15                  | 30  | 30     | —   | ns    | A6.1   |
| t <sub>high</sub> | PCI CLK High Time                 | 6                   | —   | 11     | —   | ns    | A6.2   |
| t <sub>low</sub>  | PCI CLK Low Time                  | 6                   | —   | 11     | —   | ns    | A6.3   |
| —                 | PCI CLK Slew Rate <sup>2</sup>    | 1.5                 | 4   | 1      | 4   | V/ns  | A6.4   |

- <sup>1</sup> In general, all 66 MHz PCI components must work with any clock frequency up to 66 MHz. CLK requirements vary depending upon whether the clock frequency is above 33 MHz.
- <sup>2</sup> Rise and fall times are specified in terms of the edge rate measured in V/ns. This slew rate must be met across the minimum peak-to-peak portion of the clock waveform as shown in Figure 12.
- <sup>3</sup> The minimum clock period must not be violated for any single clock cycle, i.e., accounting for all system jitter.

Table 22. PCI Timing Parameters<sup>1</sup>

| Sym                   | Description   | 66 MHz           |     | 33 MHz |     | Units | SpecID |
|-----------------------|---|------------------|-----|--------|-----|-------|--------|
|                       |   | Min <sup>2</sup> | Max | Min    | Max |       |        |
| t <sub>val</sub>      | CLK to Signal Valid Delay – based signals <sup>1,2,3</sup>  | 2                | 6   | 2      | 11  | ns    | A6.5   |
| t <sub>val(ptp)</sub> | CLK to Signal Valid Delay – point to point <sup>1,2,3</sup> | 2                | 6   | 2      | 12  | ns    | A6.6   |
| t <sub>on</sub>       | Float to Active Delay <sup>1</sup>                          | 2                | —   | 2      | —   | ns    | A6.7   |
| t <sub>off</sub>      | Active to Float Delay <sup>1</sup>                          | —                | 14  | —      | 28  | ns    | A6.8   |
| t <sub>su</sub>       | Input Setup Time to CLK – based signals <sup>3,4</sup>      | 3                | —   | 7      | —   | ns    | A6.9   |
| t <sub>su(ptp)</sub>  | Input Setup Time to CLK – point to point <sup>3,4</sup>     | 5                | —   | 10,12  | —   | ns    | A6.10  |
| t <sub>h</sub>        | Input Hold Time from CLK <sup>4</sup>                       | 0                | —   | 0      | —   | ns    | A6.11  |

- <sup>1</sup> See the timing measurement conditions in the PCI Local Bus Specification. It is important that all driven signal transitions drive to their V<sub>oh</sub> or V<sub>ol</sub> level within one T<sub>cyc</sub>.
- <sup>2</sup> Minimum times are measured at the package pin with the load circuit, and maximum times are measured with the load circuit as shown in the PCI Local Bus Specification.
- <sup>3</sup> REQ# and GNT# are point-to-point signals and have different input setup times than do bused signals. GNT# and REQ# have a setup of 5 ns at 66 MHz. All other signals are bused.

<sup>4</sup> See the timing measurement conditions in the PCI Local Bus Specification.

For Measurement and Test Conditions, see the PCI Local Bus Specification.

### 3.3.7 LPC

The Local Plus Bus is the external bus interface of the MPC5121e/MPC5123. A maximum of eight configurable chip selects (CS) are provided. There are two main modes of operation: non-MUXed and MUXED. The reference clock is the LPC CLK. The maximum bus frequency is 83 MHz.

Definition of Acronyms and Terms:

WS = Wait State  
 DC = Dead Cycle  
 HC = Hold Cycle  
 DS = Data Size in Bytes  
 BBT = Burst Bytes per Transfer  
 AL = Address latch enable Length  
 ALT = Chip select/Address Latch Timing  
 $t_{LPCck}$  = LPC clock period

**Table 23. LPC Timing**

| Sym      | Description   | Min                                    | Max                                    | Units | SpecID |
|----------|---|--|--|-------|--------|
| $t_{OD}$ | $\overline{CS}[x]$ , ADDR, R/ $\overline{W}$ , TSIZ, DATA (wr), $\overline{TS}$ , $\overline{OE}$ valid after LPC CLK (Output Delay related to LPC CLK) | 0                                      | 5                                      | ns    | A7.1   |
| $t_1$    | Non-MUXed non-Burst $\overline{CS}[x]$ pulse width  | $(2 + WS) \times t_{LPCck}$            | $(2 + WS) \times t_{LPCck}$            | ns    | A7.2   |
| $t_2$    | ADDR, R/ $\overline{W}$ , TSIZ, DATA (wr) valid before $\overline{CS}[x]$ assertion   | $t_{LPCck} - t_{OD}$                   | $t_{LPCck} + t_{OD}$                   | ns    | A7.3   |
| $t_3$    | $\overline{OE}$ assertion after $\overline{CS}[x]$ assertion  | $t_{LPCck} - t_{OD}$                   | $t_{LPCck} + t_{OD}$                   | ns    | A7.4   |
| $t_4$    | ADDR, R/ $\overline{W}$ , TSIZ, Data (wr) hold after $\overline{CS}[x]$ negation  | $t_{LPCck} - t_{OD}$                   | $(HC + 1) \times t_{LPCck} + t_{OD}$   | ns    | A7.5   |
| $t_5$    | $\overline{TS}$ pulse width   | $t_{LPCck}$                            | $t_{LPCck}$                            | ns    | A7.6   |
| $t_6$    | DATA (rd) setup before LPC CLK  | 4                                      | —                                      | ns    | A7.7   |
| $t_7$    | DATA (rd) input hold  | 0                                      | $(DC + 1) \times t_{LPCck}$            | ns    | A7.8   |
| $t_8$    | Non-MUXed read Burst $\overline{CS}[x]$ pulse width   | $(2 + WS + BBT/DS) \times t_{LPCck}$   | $(2 + WS + BBT/DS) \times t_{LPCck}$   | ns    | A7.9   |
| $t_9$    | Burst $\overline{ACK}$ pulse width  | $(BBT/DS) \times t_{LPCck}$            | $(BBT/DS) \times t_{LPCck}$            | ns    | A7.10  |
| $t_{10}$ | Burst DATA (rd) input hold  | 0                                      | —                                      | ns    | A7.11  |
| $t_{11}$ | Read Burst $\overline{ACK}$ assertion after $\overline{CS}[x]$ assertion  | $(2 + WS) \times t_{LPCck}$            | $(2 + WS) \times t_{LPCck}$            | ns    | A7.12  |
| $t_{12}$ | Non-muxed write Burst $\overline{CS}[x]$ pulse width  | $(2.5 + WS + BBT/DS) \times t_{LPCck}$ | $(2.5 + WS + BBT/DS) \times t_{LPCck}$ | ns    | A7.13  |
| $t_{13}$ | Write Burst ADDR, R/ $\overline{W}$ , TSIZ, DATA (wr) hold after $\overline{CS}[x]$ negation  | $0.5 \times t_{LPCck} - t_{OD}$        | $(HC + 0.5) \times t_{LPCck} + t_{OD}$ | ns    | A7.14  |

**Table 23. LPC Timing (continued)**

| Sym             | Description   | Min   | Max   | Units | SpecID |
|-----------------|---|---|---|-------|--------|
| t <sub>14</sub> | Write Burst $\overline{ACK}$ assertion after $\overline{CS}[x]$ assertion     | $(2.5 + WS) \times t_{LPCck} - t_{OD}$                            | $(2.5 + WS) \times t_{LPCck} + t_{OD}$                            | ns    | A7.15  |
| t <sub>15</sub> | Write Burst DATA valid  | $t_{LPCck} - t_{OD}$  | —   | ns    | A7.16  |
| t <sub>16</sub> | Non-MUXed Mode: asynchronous write Burst ADDR valid before write DATA valid   | $0.5 \times t_{LPCck} - t_{OD}$                                   | $0.5 \times t_{LPCck} + t_{OD}$                                   | ns    | A7.17  |
| t <sub>17</sub> | MUXed Mode: ADDR cycle  | $AL \times 2 \times t_{LPCck} - t_{OD}$                           | $AL \times 2 \times t_{LPCck}$                                    | ns    | A7.18  |
| t <sub>18</sub> | MUXed Mode: $\overline{ALE}$ cycle  | $AL \times t_{LPCck}$   | $AL \times t_{LPCck}$   | ns    | A7.19  |
| t <sub>19</sub> | Non-MUXed Mode Page Burst: ADDR cycle   | $t_{LPCck} - t_{OD}$  | $t_{LPCck}$   | ns    | A7.20  |
| t <sub>20</sub> | Non-MUXed Mode Page Burst: Burst DATA (rd) input setup before next ADDR cycle | $t_{OD} + t_6$  | —   | ns    | A7.21  |
| t <sub>21</sub> | Non-MUXed Mode Page Burst: Burst DATA (rd) input hold after next ADDR cycle   | 0   | —   | ns    | A7.22  |
| t <sub>22</sub> | MUXed Mode: non-Burst $\overline{CS}[x]$ pulse width                          | $(ALT \times (AL \times 2) + 2 + WS) \times t_{LPCck}$            | $(ALT \times (AL \times 2) + 2 + WS) \times t_{LPCck}$            | ns    | A7.23  |
| t <sub>23</sub> | MUXed Mode: read Burst $\overline{CS}[x]$ pulse width                         | $[ALT \times (AL \times 2) + 2 + WS + BBT/DS] \times t_{LPCck}$   | $[ALT \times (AL \times 2) + 2 + WS + BBT/DS] \times t_{LPCck}$   | ns    | A7.24  |
| t <sub>24</sub> | MUXed Mode: write Burst $\overline{CS}[x]$ pulse width                        | $[ALT \times (AL \times 2) + 2.5 + WS + BBT/DS] \times t_{LPCck}$ | $[ALT \times (AL \times 2) + 2.5 + WS + BBT/DS] \times t_{LPCck}$ | ns    | A7.25  |

### 3.3.7.1 Non-MUXed Mode

#### 3.3.7.1.1 Non-MUXed Non-Burst Mode

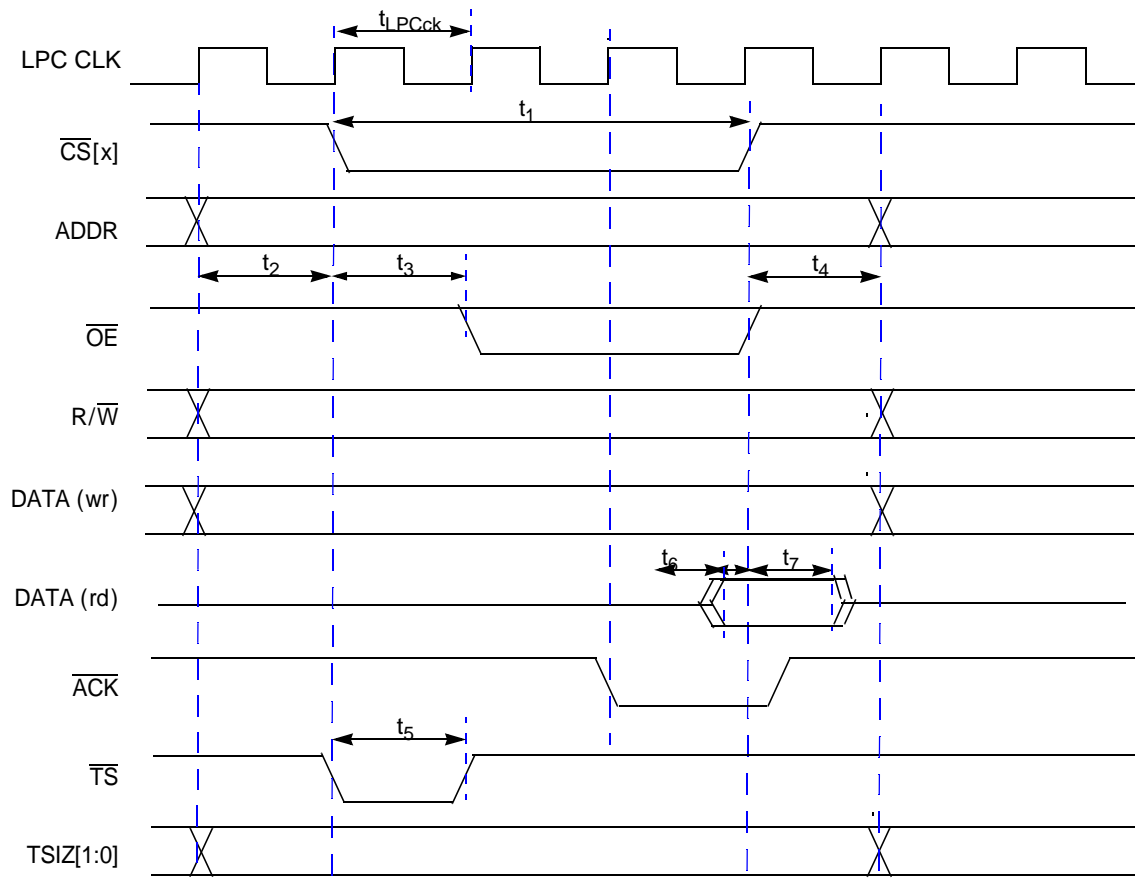

Figure 13. Timing Diagram – Non-MUXed Non-Burst Mode

#### NOTE

$\overline{ACK}$  is asynchronous input signal and has no timing requirements.  $\overline{ACK}$  needs to be deasserted after  $\overline{CS}[x]$  is deasserted.

### 3.3.7.1.2 Non-MUXed Synchronous Read Burst Mode

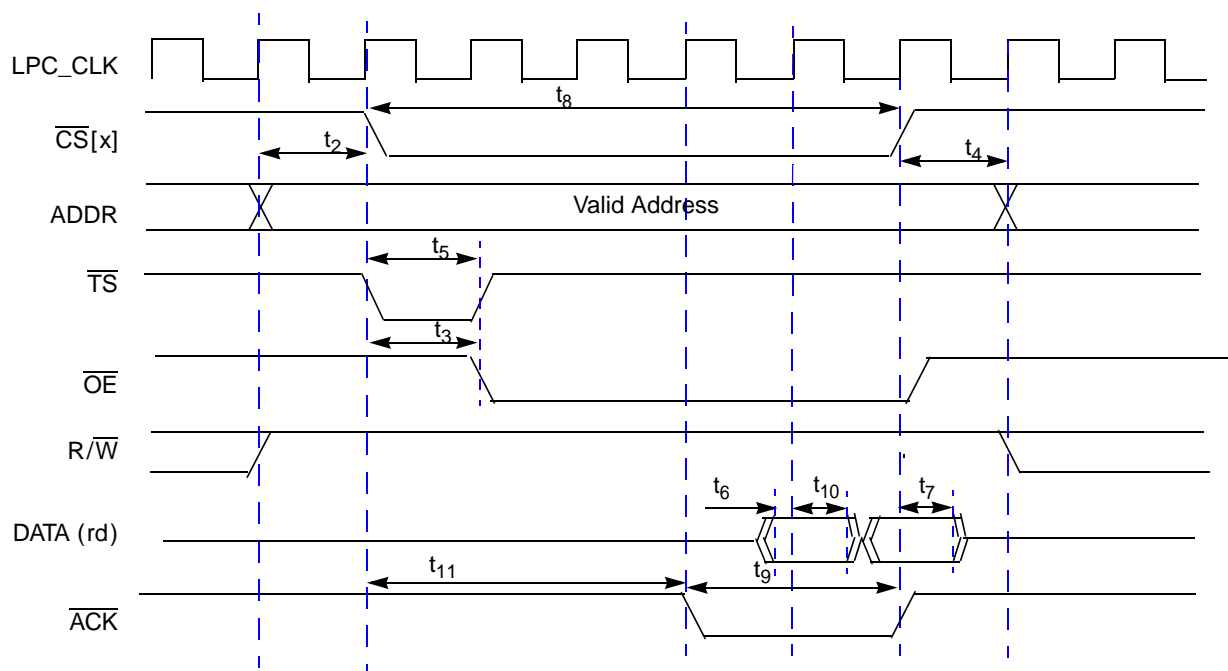

Figure 14. Timing Diagram – Non-MUXed Synchronous Read Burst Mode

### 3.3.7.1.3 Non-MUXed Synchronous Write Burst Mode

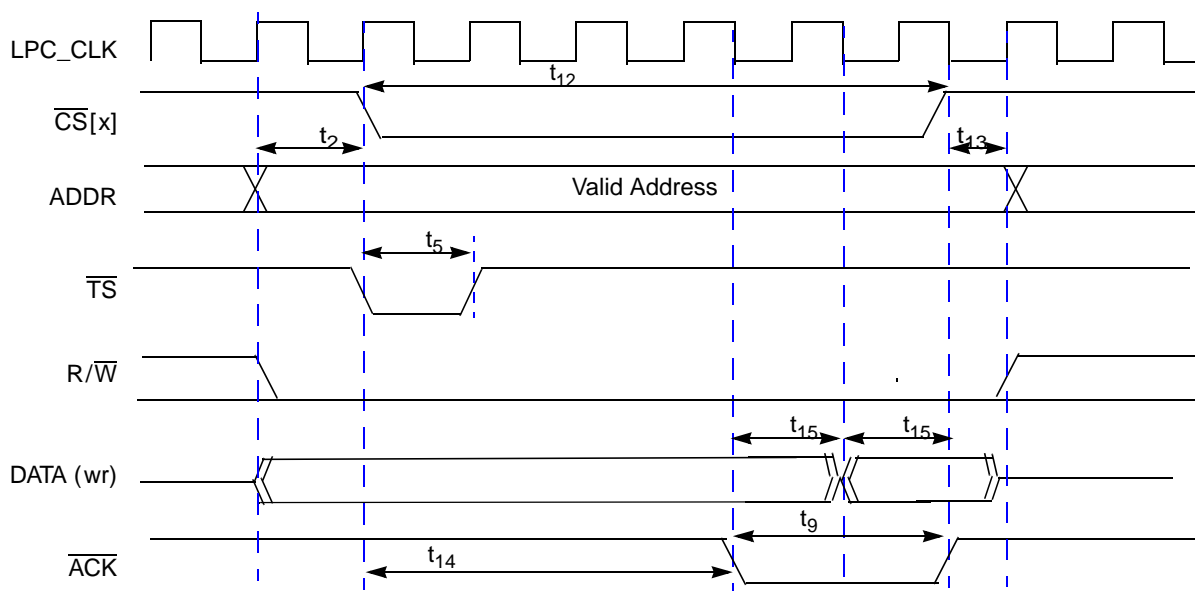

Figure 15. Timing Diagram – Non-MUXed Synchronous Write Burst



### 3.3.7.1.4 Non-MUXed Asynchronous Read Burst Mode (Page Mode)

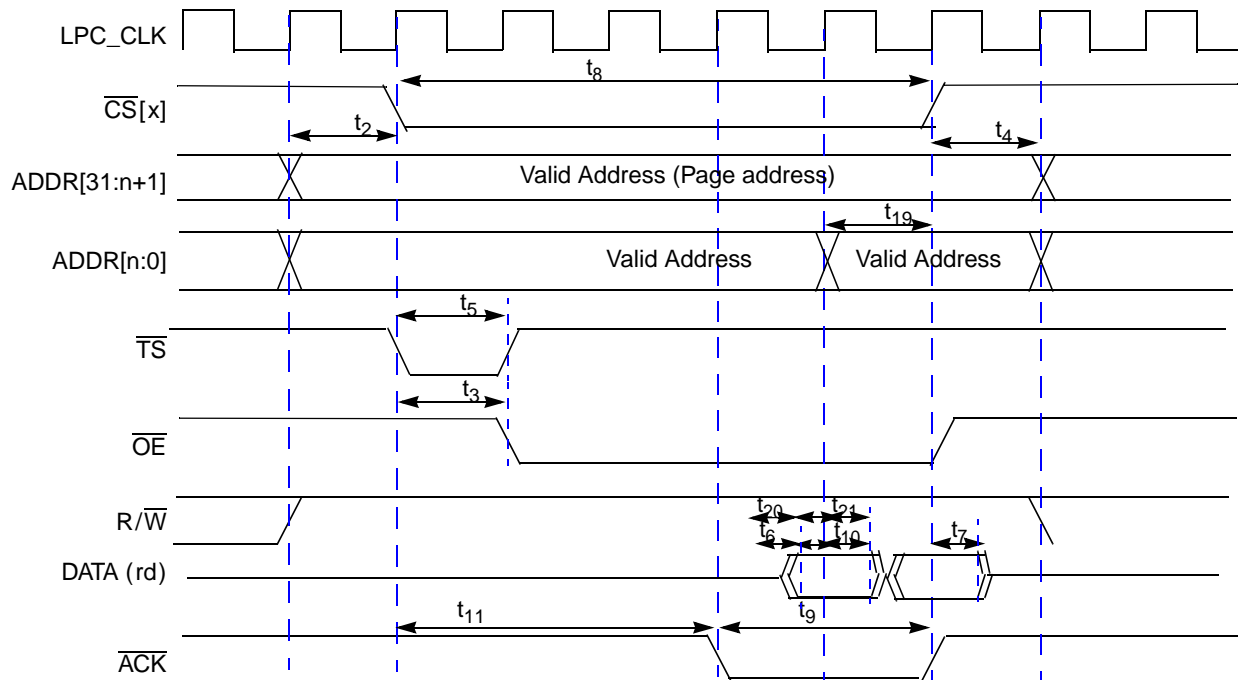

Figure 16. Timing Diagram – Non-MUXed Asynchronous Read Burst

### 3.3.7.1.5 Non-MUXed Asynchronous Write Burst Mode

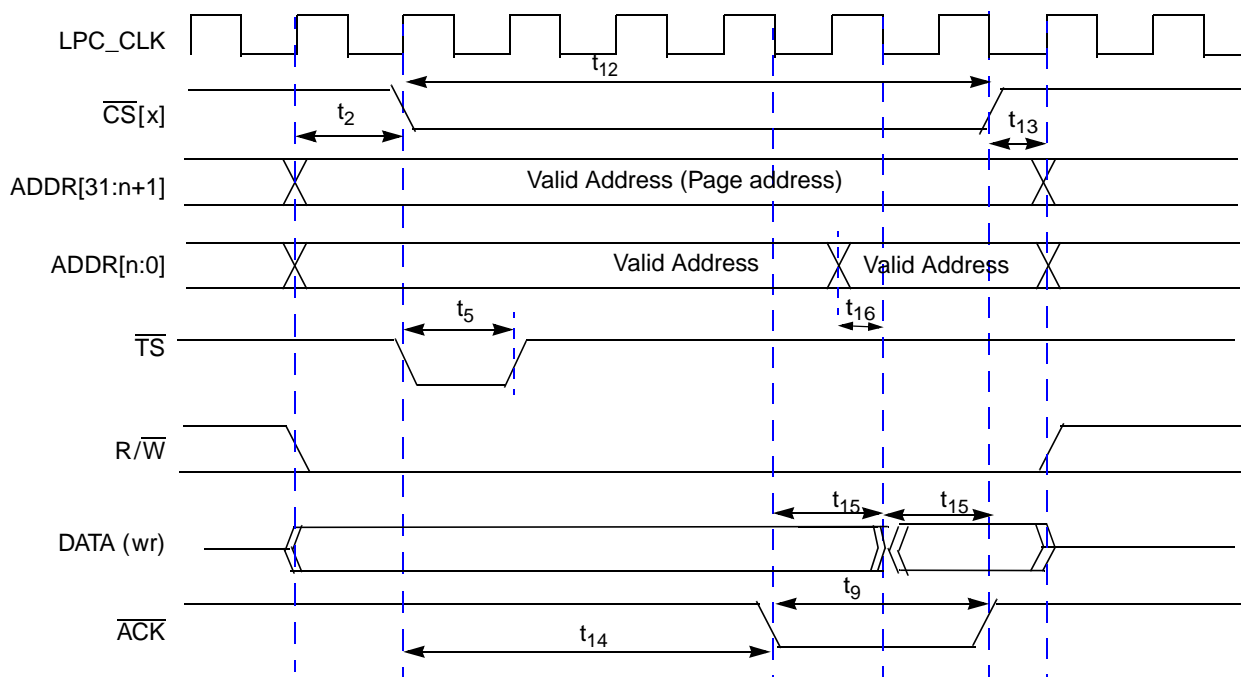

Figure 17. Timing Diagram – Non-MUXed Asynchronous Write Burst

### 3.3.7.2 MUXed Mode

#### 3.3.7.2.1 MUXed Non-Burst Mode

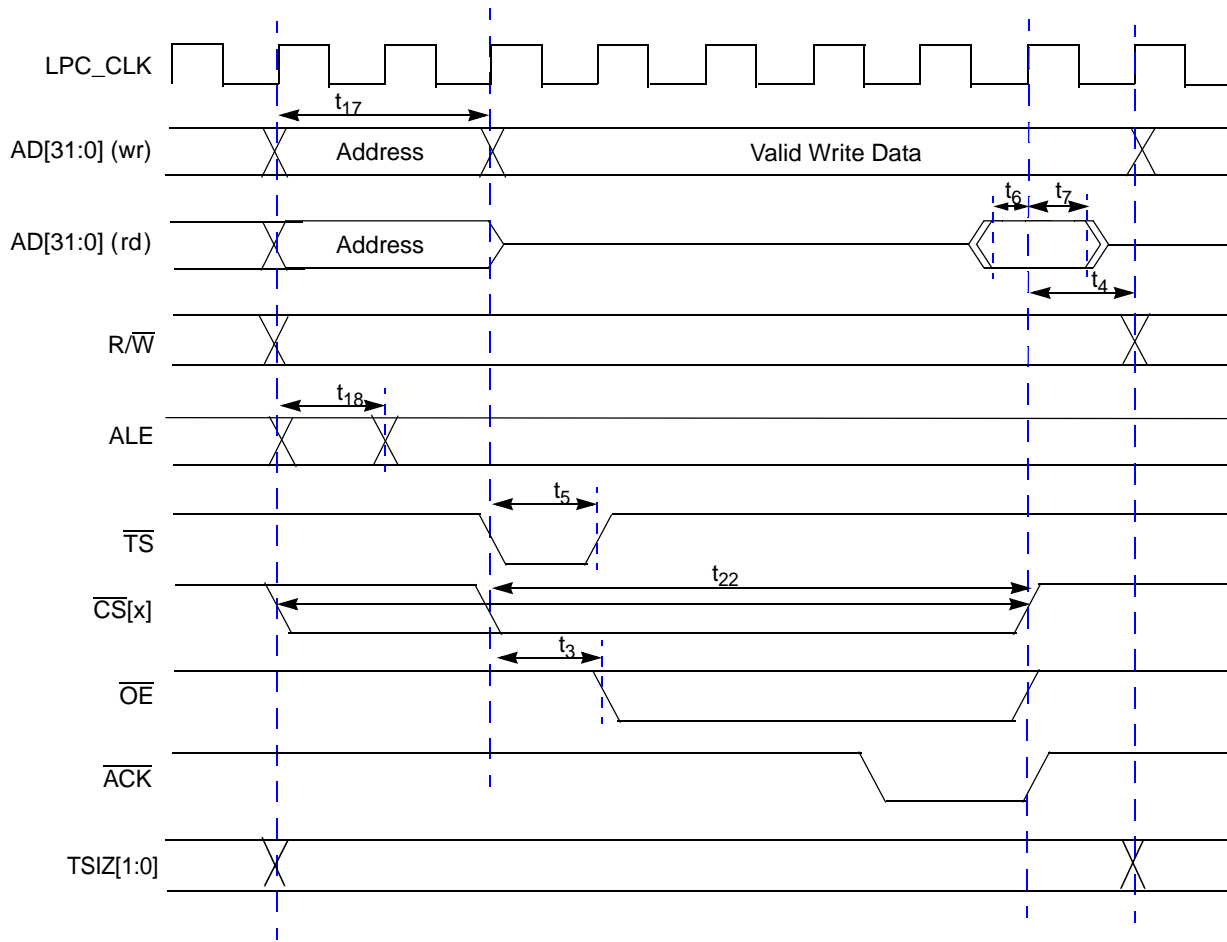

Figure 18. Timing Diagram – MUXed Non-Burst Mode

**NOTE**

$\overline{\text{ACK}}$  is asynchronous input signal and has no timing requirements.  $\overline{\text{ACK}}$  needs to be deasserted after CS[x] is deasserted.

### 3.3.7.2.2 MUXed Synchronous Read Burst Mode

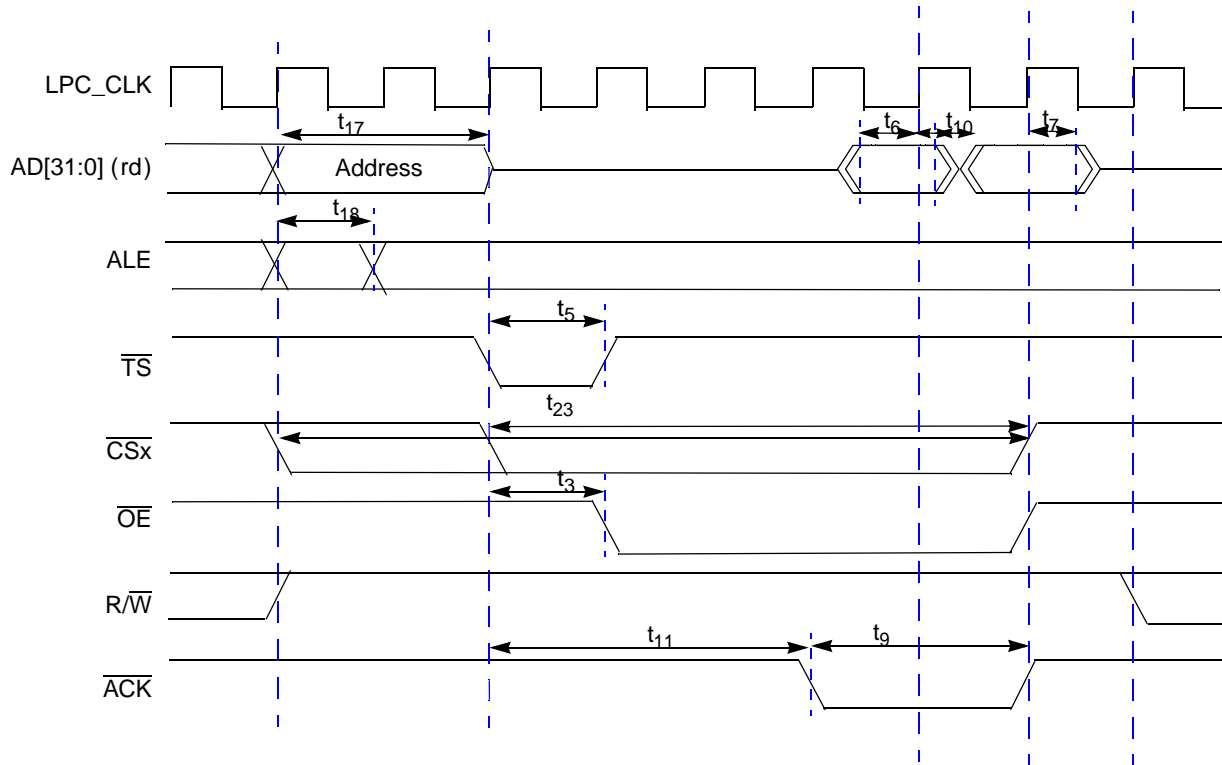

Figure 19. Timing Diagram – MUXed Synchronous Read Burst

### 3.3.7.2.3 MUXed Synchronous Write Burst Mode

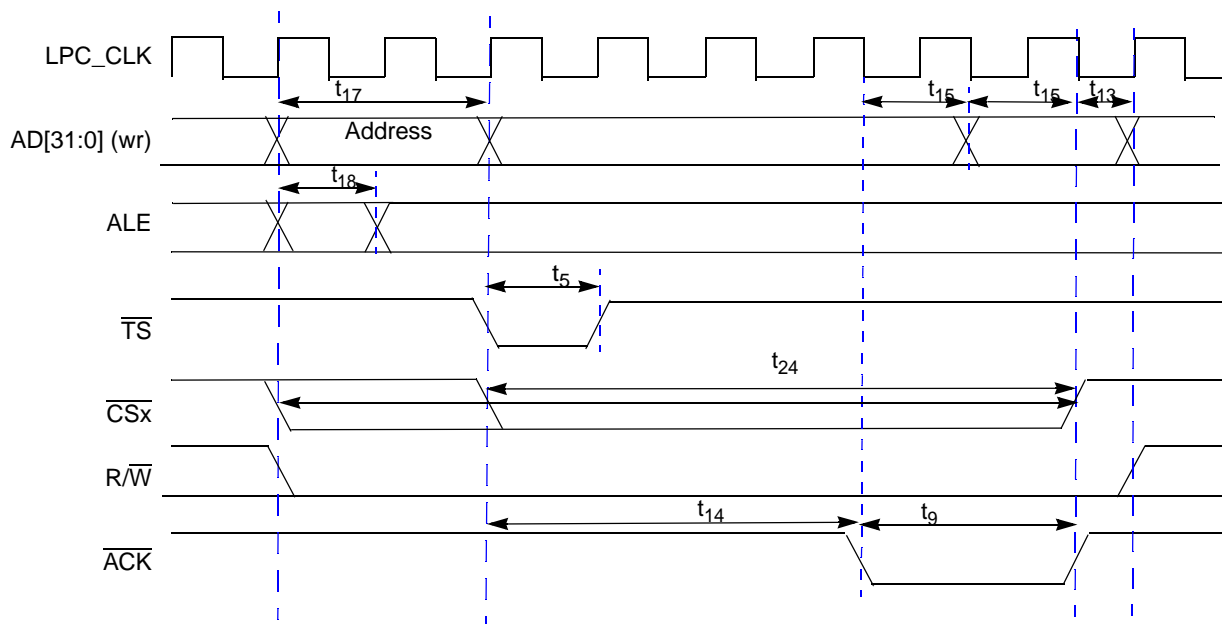

Figure 20. Timing Diagram – MUXed Synchronous Write Burst

### 3.3.8 NFC

The NAND flash controller (NFC) implements the interface to standard NAND Flash memory devices. This section describes the timing parameters of the NFC.

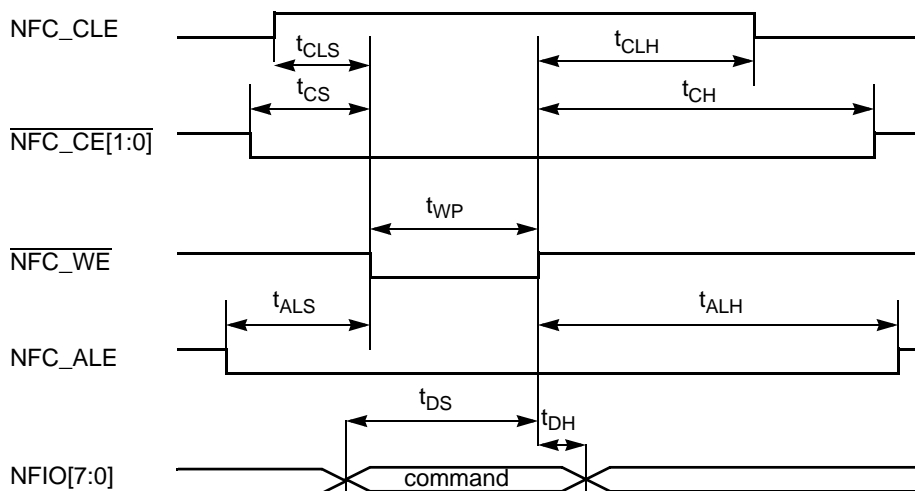

Figure 21. Command Latch Cycle Timing

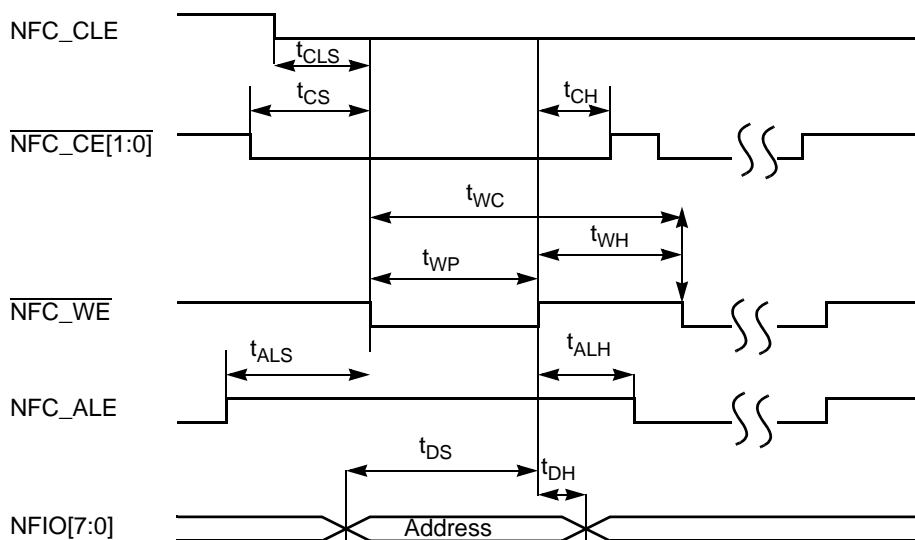

Figure 22. Address Latch Cycle Timing

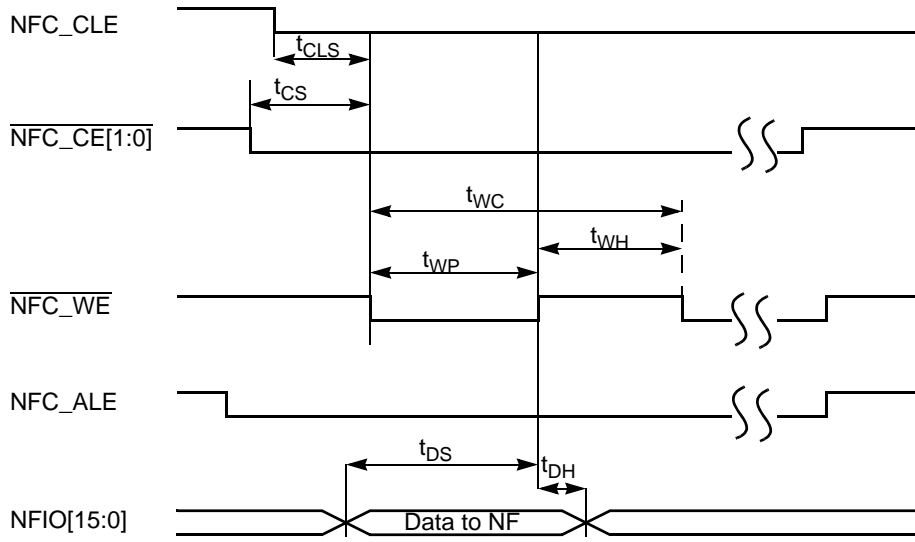

Figure 23. Write Data Latch Timing

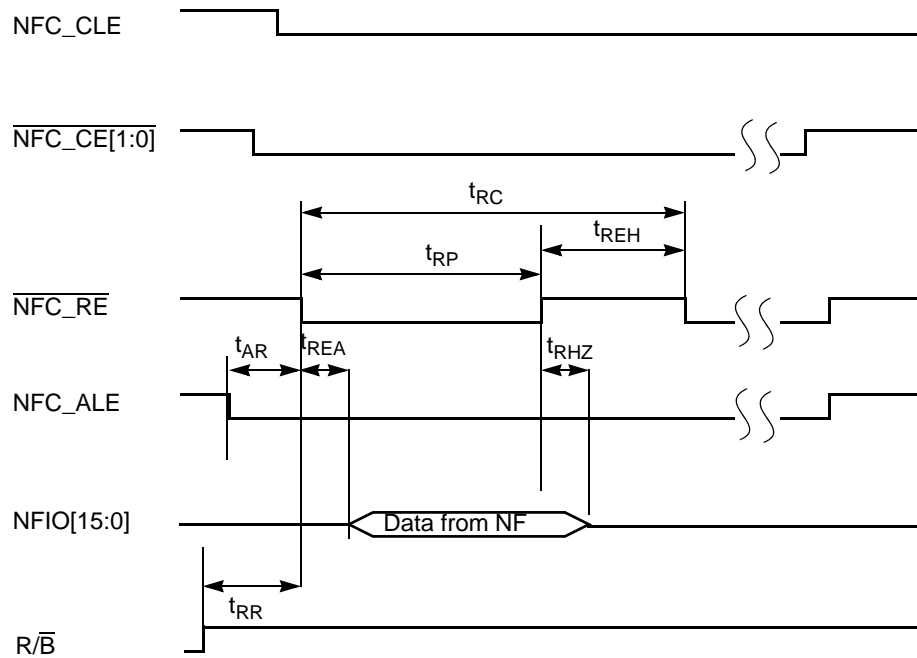

Figure 24. Read Data Latch Timing

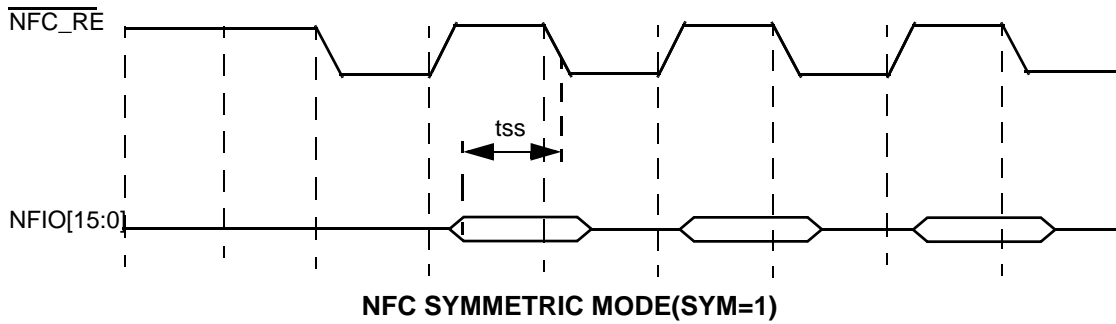

Figure 25. Read Data Latch Timing in Symmetric Mode

Table 24. NFC Timing Characteristics in asymmetric mode(SYM=0)<sup>1</sup>

| Timing parameter | Description            | Min. value | Max. value | Unit | SpecID |
|------------------|------------------------|------------|------------|------|--------|
| t <sub>CLS</sub> | NFC_CLE setup Time     | T + 1      | —          | ns   | A8.1   |
| t <sub>CLH</sub> | NFC_CLE Hold Time      | T - 1      | —          | ns   | A8.2   |
| t <sub>CS</sub>  | NFC_CE[1:0] Setup Time | 2T - 1     | —          | ns   | A8.3   |
| t <sub>CH</sub>  | NFC_CE[1:0] Hold Time  | 3T         | —          | ns   | A8.4   |
| t <sub>WP</sub>  | NFC_WP Pulse Width     | T - 1      | —          | ns   | A8.5   |
| t <sub>ALS</sub> | NFC_ALE Setup Time     | T - 1      | —          | ns   | A8.6   |
| t <sub>ALH</sub> | NFC_ALE Hold Time      | T - 1      | —          | ns   | A8.7   |
| t <sub>DS</sub>  | Data Setup Time        | T - 2      | —          | ns   | A8.8   |
| t <sub>DH</sub>  | Data Hold Time         | T - 1      | —          | ns   | A8.9   |
| t <sub>WC</sub>  | Write Cycle Time       | 2T         | —          | ns   | A8.10  |
| t <sub>WH</sub>  | NFC_WE Hold Time       | T - 1      | —          | ns   | A8.11  |
| t <sub>RR</sub>  | Ready to NFC_RE Low    | 5T + 2     | —          | ns   | A8.12  |
| t <sub>RP</sub>  | NFC_RE Pulse Width     | 1.5T - 1   | —          | ns   | A8.13  |
| t <sub>RC</sub>  | READ Cycle Time        | 2T         | —          | ns   | A8.14  |
| t <sub>REH</sub> | NFC_RE High Hold Time  | 0.5T       | —          | ns   | A8.15  |

<sup>1</sup> T is the flash clock cycle.

T = 45 ns, frequency = 22 MHz (boot configuration, IP bus = 66 MHz)

T = 36 ns, frequency = 27 MHz (maximum configurable frequency, IP bus = 83 MHz)

**Table 25. NFC Timing Characteristics in Symmetric mode(SYM=1)<sup>1</sup>**

| Timing Parameter | Description              | Min. value | Max. value | Unit | SpecID |
|------------------|--------------------------|------------|------------|------|--------|
| t <sub>CLS</sub> | NFC_CLE Setup time       | T          | —          | ns   | A8.21  |
| t <sub>CLH</sub> | NFC_CLE Hold time        | T          | —          | ns   | A8.22  |
| t <sub>CS</sub>  | NFC_CE[1:0] Setup time   | T-2        | —          | ns   | A8.23  |
| t <sub>CH</sub>  | NFC_CE[1:0] Hold time    | 1.5T-1     | —          | ns   | A8.24  |
| t <sub>WP</sub>  | NFC_WE Pulse width       | 0.5T+1     | —          | ns   | A8.25  |
| t <sub>ALS</sub> | NFC_ALE Setup time       | T          | —          | ns   | A8.26  |
| t <sub>ALH</sub> | NFC_ALE Hold time        | T          | —          | ns   | A8.27  |
| t <sub>DS</sub>  | Data Setup time          | 0.5T-3     | —          | ns   | A8.28  |
| t <sub>DH</sub>  | Data Hold time           | 0.5T       | —          | ns   | A8.29  |
| t <sub>WC</sub>  | Write Cycle time         | T          | —          | ns   | A8.30  |
| t <sub>WH</sub>  | NFC_WE Hold time         | 0.5T-1     | —          | ns   | A8.31  |
| t <sub>RR</sub>  | Ready to NFC_RE low      | 5T+2       | —          | ns   | A8.32  |
| t <sub>RP</sub>  | NFC_RE pulse width       | 0.5T       | —          | ns   | A8.33  |
| t <sub>RC</sub>  | Read Cycle time          | T          | —          | ns   | A8.34  |
| t <sub>REH</sub> | NFC_RE High hold time    | 0.5T       | —          | ns   | A8.35  |
| t <sub>SS</sub>  | NFC Read Data setup time | 9.6        | —          | ns   | A8.36  |

<sup>1</sup> T is the flash clock cycle.

T = 45 ns, frequency = 22 MHz (boot configuration, IP bus = 66 MHz)

T = 36 ns, frequency = 27 MHz (maximum configurable frequency, IP bus = 83 MHz)

### 3.3.9 PATA

The MPC5121e/MPC5123 ATA Controller (PATA) is completely software programmable. It can be programmed to operate with ATA protocols using their respective timing, as described in the ANSI ATA-4 specification. The ATA interface is completely asynchronous in nature. Signal relationships are based on specific fixed timing in terms of timing units (nanoseconds).

ATA data setup and hold times, with respect to Read/Write strobes, are software programmable inside the ATA Controller. Data setup and hold times are implemented using counters. The counters count the number of ATA clock cycles needed to meet the ANSI ATA-4 timing specifications. For details, see the ANSI ATA-4 specification and how to program an ATA Controller and ATA drive for different ATA protocols and their respective timing. See the *MPC5121e Microcontroller Reference Manual*.

The MPC5121e/MPC5123 ATA Host Controller design makes data available coincidentally with the active edge of the WRITE strobe in PIO and Multiword DMA modes.

- Write data is latched by the drive at the inactive edge of the WRITE strobe. This gives ample setup-time beyond that required by the ATA-4 specification.
- Data is held unchanged until the next active edge of the WRITE strobe. This gives ample hold-time beyond that required by the ATA-4 specification.

## Electrical and Thermal Characteristics

All ATA transfers are programmed in terms of system clock cycles (IP bus clocks) in the ATA Host Controller timing registers. This puts constraints on the ATA protocols and their respective timing modes in which the ATA Controller can communicate with the drive.

Faster ATA modes (i.e., UDMA 0, 1, 2) are supported when the system is running at a sufficient frequency to provide adequate data transfer rates. Adequate data transfer rates are a function of the following:

- The MPC5121e/MPC5123 operating frequency (IP bus clock frequency)
- Internal MPC5121e/MPC5123 bus latencies
- Other system load dependent variables

The ATA clock is the same frequency as the IP bus clock in MPC5121e/MPC5123. See the *MPC5121e Microcontroller Reference Manual*.

### NOTE

All output timing numbers are specified for nominal 50 pF loads.

### 3.3.9.1 PATA Timing Parameters

In the timing equations, some timing parameters are used. These parameters depend on the implementation of the ATA interface in silicon, the bus transceiver used, the cable delay and cable skew. The parameters shown in [Table 3-26](#) specify the ATA timing.

**Table 3-26. PATA Timing Parameters**

| Name                | Meaning   | Controlled by    | Value  | SpecID |
|---------------------|---|------------------|--------|--------|
| T                   | PATA Bus clock period   | MPC5121E/MPC5123 | 15 ns  | A9.1   |
| t <sub>ids</sub>    | Set-up time ATA_DATA to ATA_IORDY edge (UDMA-in only)   | MPC5121E/MPC5123 | 2 ns   | A9.2   |
| t <sub>idh</sub>    | Hold time ATA_IORDY edge to ATA_DATA (UDMA-in only)   | MPC5121E/MPC5123 | 5 ns   | A9.3   |
| t <sub>co</sub>     | Propagation delay bus clock L-to-H to: ATA_CS0, ATA_CS1, ATA_DA2, ATA_DA1, ATA_DA0, ATA_DIOR, ATA_DIOW, ATA_DMACK, ATA_DATA, ATA_BUFFER_EN  | MPC5121E/MPC5123 | 2 ns   | A9.4   |
| t <sub>su</sub>     | Set-up time ATA_DATA to bus clock L-to-H  | MPC5121E/MPC5123 | 2 ns   | A9.5   |
| t <sub>sui</sub>    | Set-up time ATA_IORDY to bus clock H-to-L   | MPC5121E/MPC5123 | 2 ns   | A9.6   |
| t <sub>hi</sub>     | Hold time ATA_IORDY to bus clock H to L   | MPC5121E/MPC5123 | 2 ns   | A9.7   |
| t <sub>skew1</sub>  | Max difference in propagation delay bus clock L-to-H to any of following signals: ATA_CS0, ATA_CS1, ATA_DA2, ATA_DA1, ATA_DA0, ATA_DIOR, ATA_DIOW, ATA_DMACK, ATA_DATA (WRITE), ATA_BUFFER_EN | MPC5121E/MPC5123 | 1.7 ns | A9.8   |
| t <sub>skew2</sub>  | Max difference in buffer propagation delay for any of following signals: ATA_CS0, ATA_CS1, ATA_DA2, ATA_DA1, ATA_DA0, ATA_DIOR, ATA_DIOW, ATA_DMACK, ATA_DATA (WRITE), ATA_BUFFER_EN          | Transceiver      |        | A9.9   |
| t <sub>skew3</sub>  | Max difference in buffer propagation delay for any of following signals: ATA_IORDY, ATA_DATA (read)   | Transceiver      |        | A9.10  |
| t <sub>buf</sub>    | Max buffer propagation delay  | Transceiver      |        | A9.11  |
| t <sub>cable1</sub> | Cable propagation delay for ata_data  | Cable            |        | A9.12  |
| t <sub>cable2</sub> | Cable propagation delay for control signals: ATA_DIOR, ATA_DIOW, ATA_IORDY, ATA_DMACK   | Cable            |        | A9.13  |

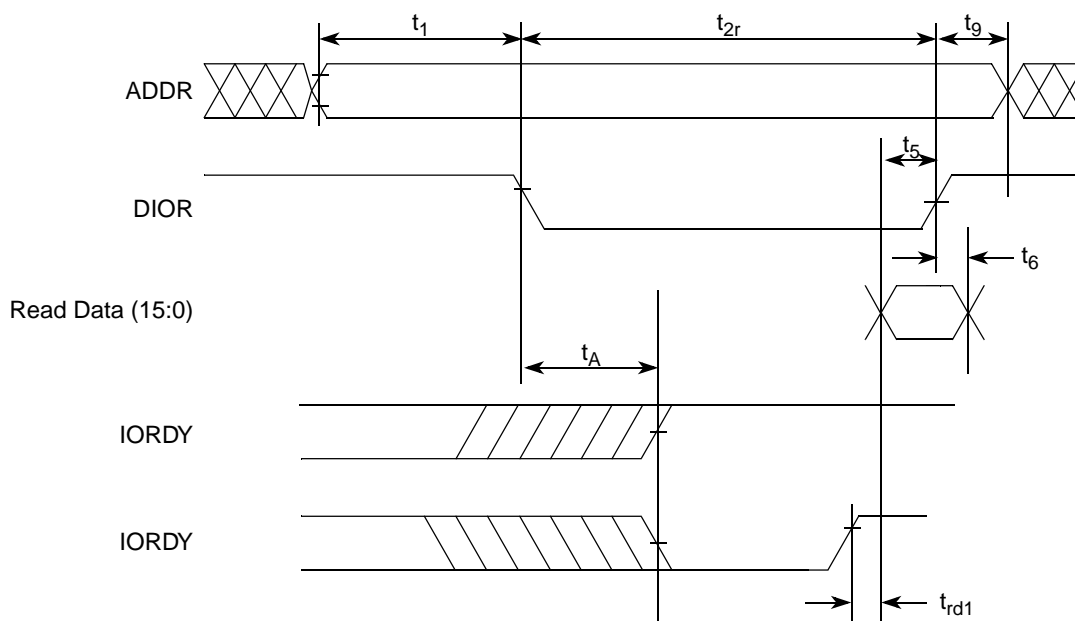

**Table 3-26. PATA Timing Parameters (continued)**

| Name        | Meaning  | Controlled by | Value | SpecID |
|-------------|--|---------------|-------|--------|
| $t_{skew4}$ | Max difference in cable propagation delay between: ATA_IORDY and ATA_DATA (read)   | Cable         |       | A9.14  |
| $t_{skew5}$ | Max difference in cable propagation delay between: ATA_DIOR, ATA_DIOW, ATA_DMACK and ATA_CS0, ATA_CS1, ATA_DA2, ATA_DA1, ATA_DA0, ATA_DATA (write) | Cable         |       | A9.15  |
| $t_{skew6}$ | Max difference in cable propagation delay without accounting for ground bounce   | Cable         |       | A9.16  |

### 3.3.9.2 PIO Mode Timing

A timing diagram for the PIO read mode is given in Figure 26.

**Figure 26. PIO Read Mode Timing**

To fulfill read mode timing, the different timing parameters given in Table 3-27 must be observed.

**Table 3-27. Timing Parameters PIO Read**

| ATA Parameter | PIO Read Mode Timing Parameter | Value  | How to meet                                     | SpecID |
|---------------|--------------------------------|--|---|--------|
| $t_1$         | $t_1$                          | $t_1(\min) = (\text{time\_1} \times T) - (t_{skew1} + t_{skew2} + t_{skew5})$  | calculate and programming time_1. <sup>1</sup>  | A9.20  |
| $t_2$         | $t_{2r}$                       | $t_2(\min) = (\text{time\_2r} \times T) - (t_{skew1} + t_{skew2} + t_{skew5})$ | calculate and programming time_2r. <sup>1</sup> | A9.21  |
| $t_9$         | $t_9$                          | $t_9(\min) = (\text{time\_9} \times T) - (t_{skew1} + t_{skew2} + t_{skew6})$  | calculate and programming time_9. <sup>1</sup>  | A9.22  |

**Table 3-27. Timing Parameters PIO Read (continued)**

| ATA Parameter | PIO Read Mode Timing Parameter | Value   | How to meet  | SpecID |
|---------------|--------------------------------|---|--|--------|
| $t_5$         | $t_5$                          | $t_5(\min) = t_{co} + t_{su} + t_{buf} + t_{buf} + t_{cable1} + t_{cable2}$   | If not met, increase time_2r                         | A9.23  |
| $t_6$         | $t_6$                          | 0   | —  | A9.24  |
| $t_A$         | $t_A$                          | $t_{A(\min)} = (1.5 + \text{time\_ax}) \times T - (t_{co} + t_{sui} + t_{cable2} + t_{cable2} + 2 \times t_{buf})$  | calculate and programming time_ax. <sup>1</sup>      | A9.25  |
| $t_{rd}$      | $t_{rd1}$                      | $t_{rd1(\max)} = (-t_{rd}) + (t_{skew3} + t_{skew4})$<br>$t_{rd1(\min)} = (\text{time\_pio\_rdx} - 0.5) \times T - (t_{su} + t_{hi})$<br>$(\text{time\_pio\_rdx} - 0.5) \times T > t_{su} + t_{hi} + t_{skew3} + t_{skew4}$ | calculate and programming time_pio_rdx. <sup>1</sup> | A9.26  |
| $t_0$         | —                              | $t_0(\min) = (\text{time\_1} + \text{time\_2} + \text{time\_9}) \times T$   | time_1, time_2r, time_9                              | A9.27  |

<sup>1</sup> See the MPC5121e Microcontroller Reference Manual.

In PIO write mode, timing waveforms are somewhat different as shown in Figure 27.

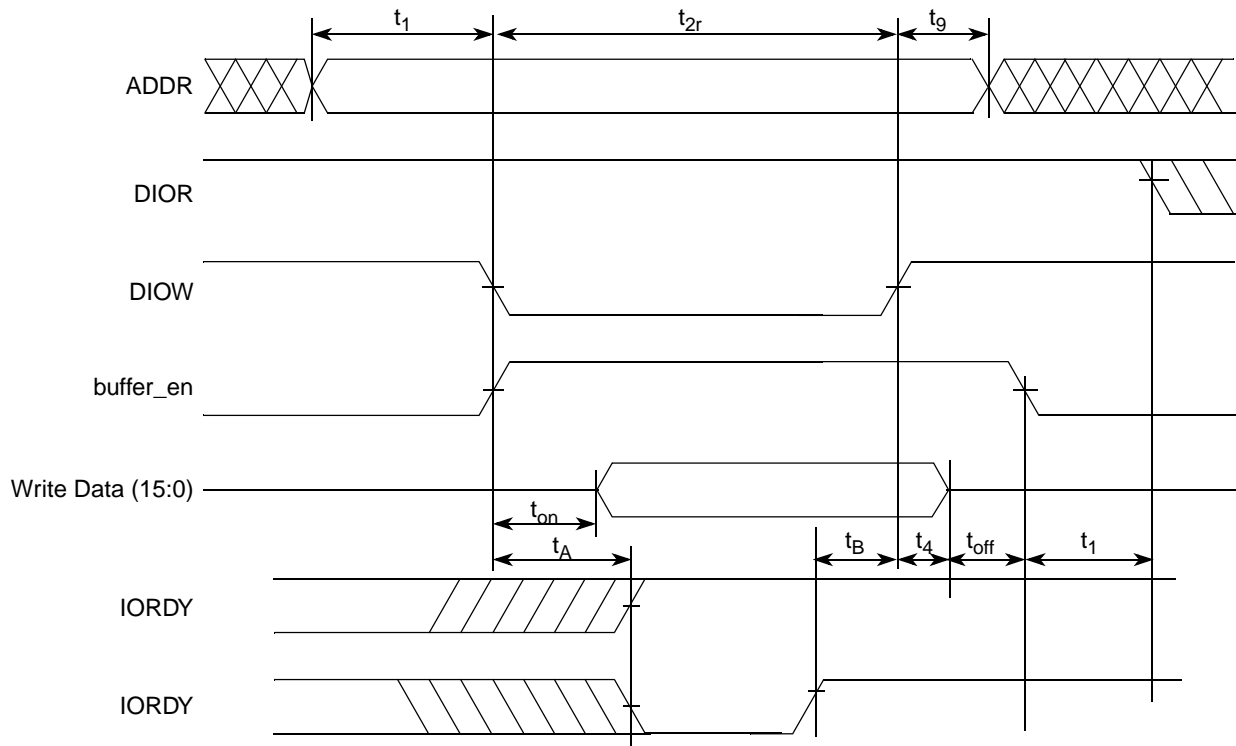

**Figure 27. PIO Write Mode Timing**

To fulfill this timing, several parameters need to be observed as shown in Table 3-28.

Table 3-28. Timing Parameters PIO Write

| ATA Parameter | PIO Write Mode Timing Parameter | Value   | How to meet                                     | SpecID |
|---------------|---------------------------------|---|---|--------|
| t1            | t1                              | $t1(\text{min}) = \text{time\_1} \times T - (\text{tskew1} + \text{tskew2} + \text{tskew5})$                                  | time_1. <sup>1</sup>                            | A9.30  |
| t2            | t2r                             | $t2(\text{min}) = \text{time\_2w} \times T - (\text{tskew1} + \text{tskew2} + \text{tskew5})$                                 | calculate and programming time_2w. <sup>1</sup> | A9.31  |
| t9            | t9                              | $t9(\text{min}) = \text{time\_9} \times T - (\text{tskew1} + \text{tskew2} + \text{tskew6})$                                  | time_9. <sup>1</sup>                            | A9.32  |
| t3            | —                               | $t3(\text{min}) = (\text{time\_2w} - \text{time\_on}) \times T - (\text{tskew1} + \text{tskew2} + \text{tskew5})$             | If not met, increase time_2w                    | A9.33  |
| t4            | t4                              | $t4(\text{min}) = \text{time\_4} \times T - \text{tskew1}$  | calculate and programming time_4. <sup>1</sup>  | A9.34  |
| tA            | tA                              | $tA = (1.5 + \text{time\_ax}) \times T - (\text{tco} + \text{tsui} + \text{tcable2} + \text{tcable2} + 2 \times \text{tbuf})$ | calculate and programming time_ax. <sup>1</sup> | A9.35  |
| t0            | —                               | $t0(\text{min}) = (\text{time\_1} + \text{time\_2} + \text{time\_9}) \times T$  | time_1, time_2r, time_9                         | A9.36  |
| —             | —                               | Avoid bus contention when switching buffer on by making ton long enough   | —   | A9.37  |
| —             | —                               | Avoid bus contention when switching buffer off by making toff long enough   | —   | A9.38  |

<sup>1</sup> See the MPC5121e Microcontroller Reference Manual.

### 3.3.9.3 Timing in Multiword DMA Mode

Timing in multiword DMA mode is given in [Figure 28](#) and [Figure 29](#).

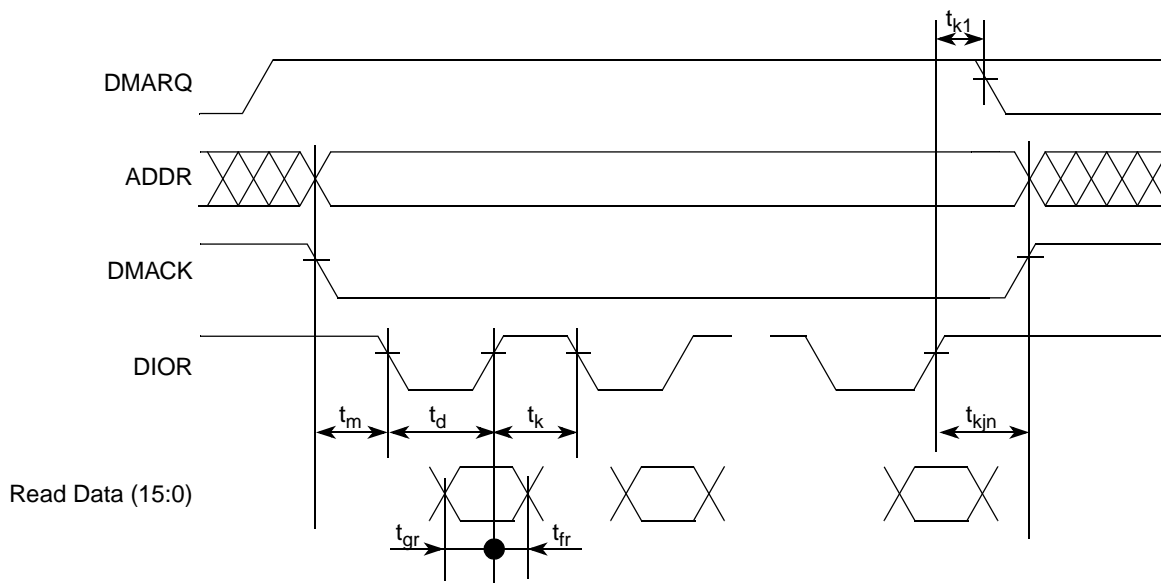

Figure 28. MDMA Read Timing

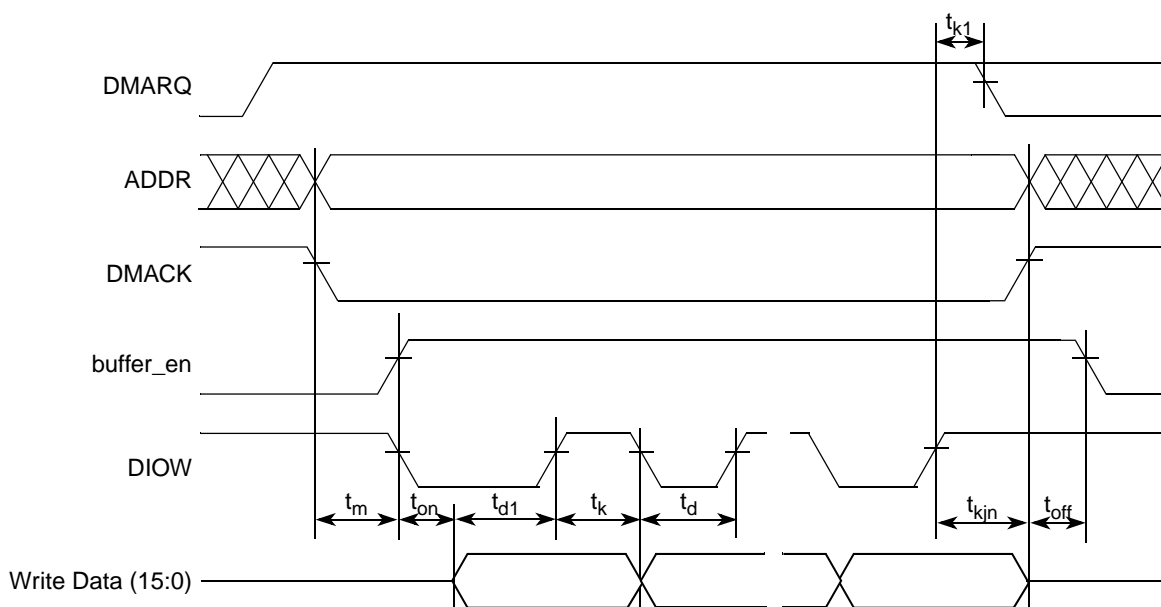

Figure 29. MDMA Write Timing

To meet this timing, a number of timing parameters must be controlled as shown in [Table 3-29](#).

Table 3-29. Timing Parameters MDMA Read and Write

| ATA Parameter         | MDMA Read/Write Timing Parameter | Value   | How to meet                                     | SpecID |
|-----------------------|----------------------------------|---|---|--------|
| $t_m, t_i$            | $t_m$                            | $t_{m(\min)} = t_{i(\min)} = (\text{time\_m} \times T) - (t_{\text{skew1}} + t_{\text{skew2}} + t_{\text{skew5}})$                                | calculate and programming time_m. <sup>1</sup>  | A9.40  |
| $t_d$                 | $t_d, t_{d1}$                    | $t_{d1(\min)} = t_{d(\min)} = (\text{time\_d} \times T) - (t_{\text{skew1}} + t_{\text{skew2}} + t_{\text{skew6}})$                               | calculate and programming time_d. <sup>1</sup>  | A9.41  |
| $t_k$                 | $t_k$                            | $t_{k(\min)} = (\text{time\_k} \times T) - (t_{\text{skew1}} + t_{\text{skew2}} + t_{\text{skew6}})$  | calculate and programming time_k. <sup>1</sup>  | A9.42  |
| $t_0$                 | —                                | $t_{0(\min)} = (\text{time\_d} + \text{time\_k}) \times T$  | time_d, time_k                                  | A9.43  |
| $t_{g(\text{read})}$  | $t_{gr}$                         | $t_{gr(\text{min-read})} = t_{co} + t_{su} + t_{buf} + t_{buf} + t_{cable1} + t_{cable2}$<br>$t_{gr(\text{min-drive})} = t_d - t_e(\text{drive})$ | time_d. <sup>1</sup>                            | A9.44  |
| $t_{f(\text{read})}$  | $t_{fr}$                         | $t_{fr(\text{min-drive})} = 0$  | —   | A9.45  |
| $t_{g(\text{write})}$ | —                                | $t_{g(\text{min-write})} = \text{time\_d} \times T - (t_{\text{skew1}} + t_{\text{skew2}} + t_{\text{skew5}})$                                    | time_d  | A9.46  |
| $t_{f(\text{write})}$ | —                                | $t_{f(\text{min-write})} = \text{time\_k} \times T - (t_{\text{skew1}} + t_{\text{skew2}} + t_{\text{skew6}})$                                    | time_k  | A9.47  |
| $t_L$                 | —                                | $t_{L(\text{max})} = [(\text{time\_d} + \text{time\_k} - 2) \times T]$<br>$- [t_{su} + t_{co} + (2 \times t_{buf}) + (2 \times t_{cable2})]$      | time_d, time_k                                  | A9.48  |
| $t_n, t_j$            | $t_{kjn}$                        | $t_n = t_j = t_{kjn} = [\max(\text{time\_k}, \text{time\_jn}) \times T]$<br>$- (t_{\text{skew1}} + t_{\text{skew2}} + t_{\text{skew6}})$          | calculate and programming time_jn. <sup>1</sup> | A9.49  |
| —                     | $t_{on}$<br>$t_{off}$            | $t_{on} = (\text{time\_on} \times T) - t_{\text{skew1}}$<br>$t_{off} = (\text{time\_off} \times T) - t_{\text{skew1}}$                            | —   | A9.50  |

<sup>1</sup> See the MPC5121e Microcontroller Reference Manual.

### 3.3.9.4 UDMA In Timing Diagrams

UDMA mode timing is more complicated than PIO mode or MDMA mode. In this section, timing diagrams for UDMA in are given:

- [Figure 30](#) gives timing for UDMA in transfer start
- [Figure 31](#) gives timing for host terminating UDMA in transfer
- [Figure 32](#) gives timing for device terminating UDMA in transfer.

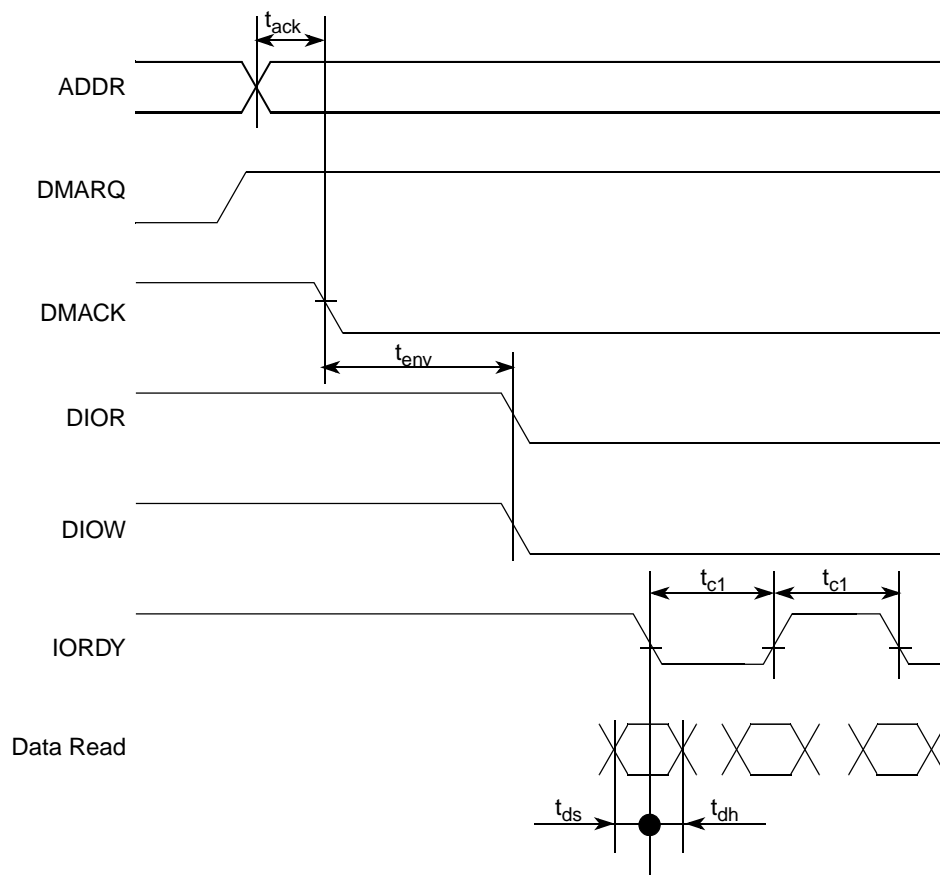

Figure 30. UDMA In Transfer Start Timing Diagram

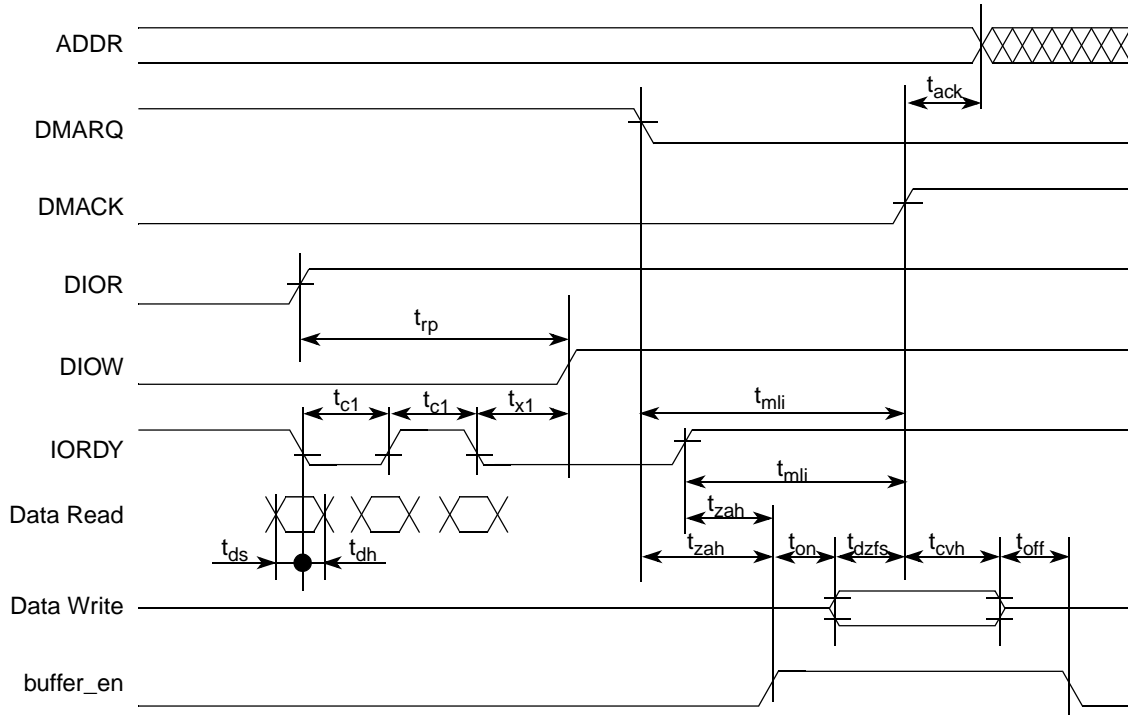

Figure 31. UDMA In Host Terminates Transfer

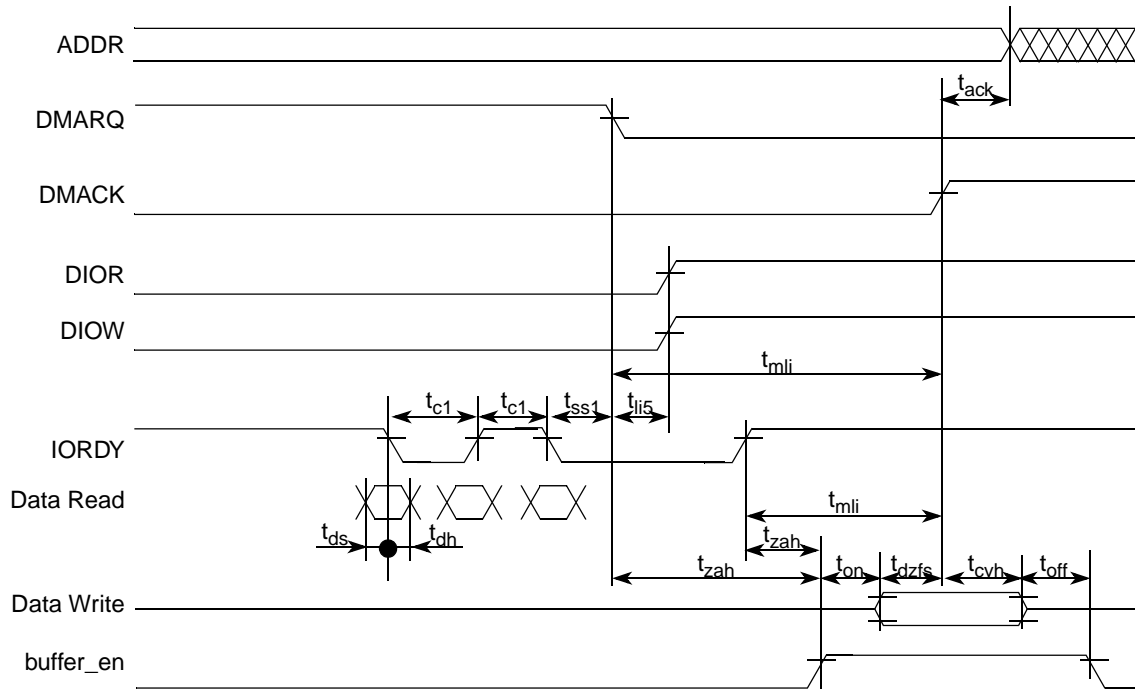

Figure 32. UDMA In Device Terminates Transfer

Timing parameters are explained in [Table 30](#).

**Table 30. Timing Parameters UDMA in Burst**

| ATA Parameter | UDMA In Timing Parameter  | Value  | How to Meet                                       | SpecID |
|---------------|---------------------------|--|---|--------|
| $t_{ack}$     | $t_{ack}$                 | $t_{ack(min)} = (time\_ack \times T) - (t_{skew1} + t_{skew2})$  | calculate and programming time_ack. <sup>1</sup>  | A9.51  |
| $t_{env}$     | $t_{env}$                 | $t_{env(min)} = (time\_env \times T) - (t_{skew1} + t_{skew2})$<br>$t_{env(max)} = (time\_env \times T) + (t_{skew1} + t_{skew2})$ | calculate and programming time_env. <sup>1</sup>  | A9.52  |
| $t_{ds}$      | $t_{ds1}$                 | $t_{ds} - (t_{skew3}) - ti\_ds > 0$  | $t_{skew3}, ti\_ds, ti\_dh$ should be low enough  | A9.53  |
| $t_{dh}$      | $t_{dh1}$                 | $t_{dh} - (t_{skew3}) - ti\_dh > 0$  |   | A9.54  |
| $t_{cyc}$     | $t_{c1}$                  | $(t_{cyc} - t_{skew}) > T$   | Bus clock period T big enough                     | A9.55  |
| $t_{rp}$      | $t_{rp}$                  | $t_{rp(min)} = time\_rp \times T - (t_{skew1} + t_{skew2} + t_{skew6})$  | calculate and programming time_rp. <sup>1</sup>   | A9.56  |
| —             | $t_{x1}^2$                | $(time\_rp \times T) - [t_{co} + t_{su} + 3T + (2 \times t_{buf}) + (2 \times t_{cable2})] > trfs$ (drive)                         | calculate and programming time_rp. <sup>1</sup>   | A9.57  |
| $t_{mli}$     | $t_{mli1}$                | $t_{mli1(min)} = (time\_mlix + 0.4) \times T$  | calculate and programming time_mlix. <sup>1</sup> | A9.58  |
| $t_{zah}$     | $t_{zah}$                 | $t_{zah(min)} = (time\_zah + 0.4) \times T$  | calculate and programming time_zah. <sup>1</sup>  | A9.59  |
| $t_{dzfs}$    | $t_{dzfs}$                | $t_{dzfs} = (time\_dzfs \times T) - (t_{skew1} + t_{skew2})$   | calculate and programming time_dzfs. <sup>1</sup> | A9.60  |
| $t_{cvh}$     | $t_{cvh}$                 | $t_{cvh} = (time\_cvh \times T) - (t_{skew1} + t_{skew2})$   | calculate and programming time_cvh. <sup>1</sup>  | A9.61  |
| —             | $t_{on}^3$<br>$t_{off}^3$ | $t_{on} = (time\_on \times T) - t_{skew1}$<br>$t_{off} = (time\_off \times T) - t_{skew1}$   | —   | A9.62  |

<sup>1</sup> See the MPC5121e Microcontroller Reference Manual.

<sup>2</sup> A special timing requirement in the ATA host requires the internal D1OW to go only high three clocks after the last active edge on the DSTROBE signal. The equation given on this line tries to capture this constraint.

<sup>3</sup> Make  $t_{on}$  and  $t_{off}$  large enough to avoid bus contention.

### 3.3.9.5 UDMA Out Timing Diagrams

UDMA mode timing is more complicated than PIO mode or MDMA mode. In this section, timing diagrams for UDMA out are given:

- [Figure 33](#) gives timing for UDMA out transfer start
- [Figure 34](#) gives timing for host terminating UDMA out transfer
- [Figure 35](#) gives timing for device terminating UDMA out transfer



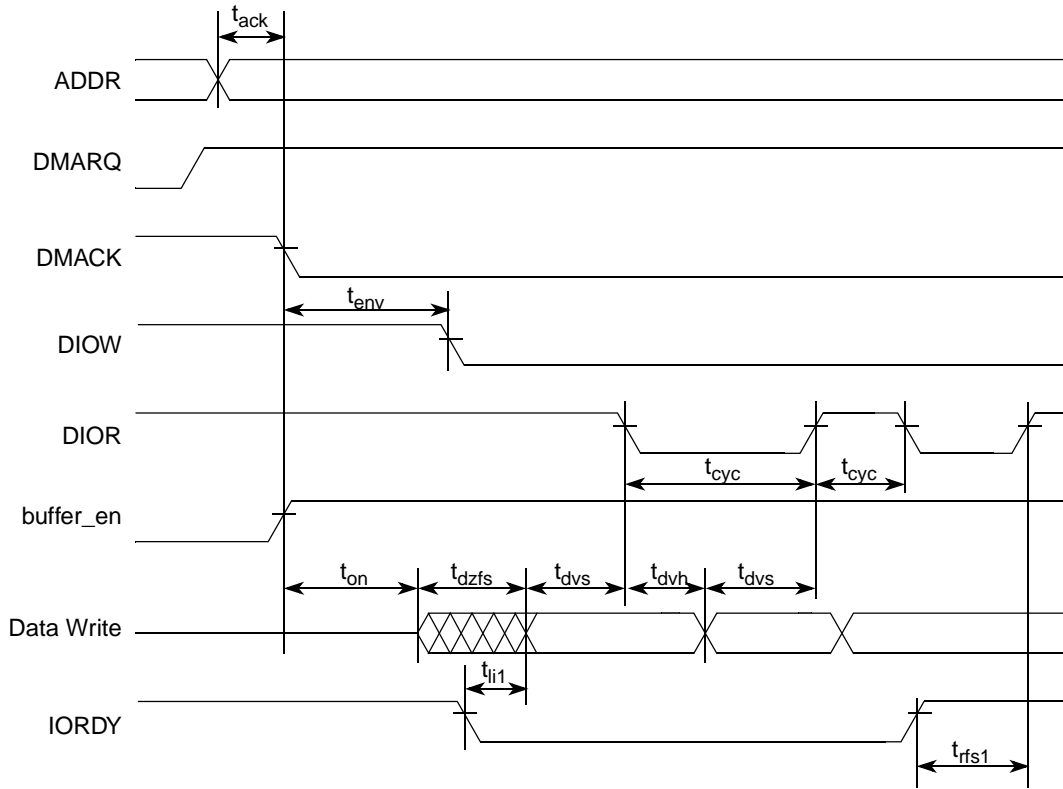

Figure 33. UDMA Out Transfer Start Timing Diagram

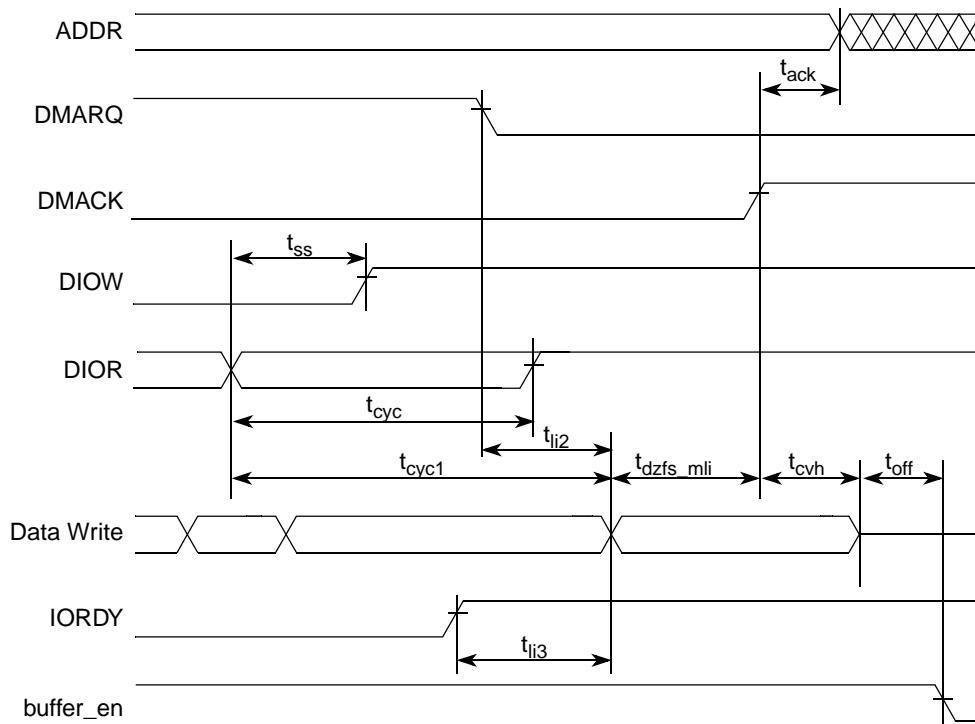

Figure 34. UDMA Out Host Terminates Transfer

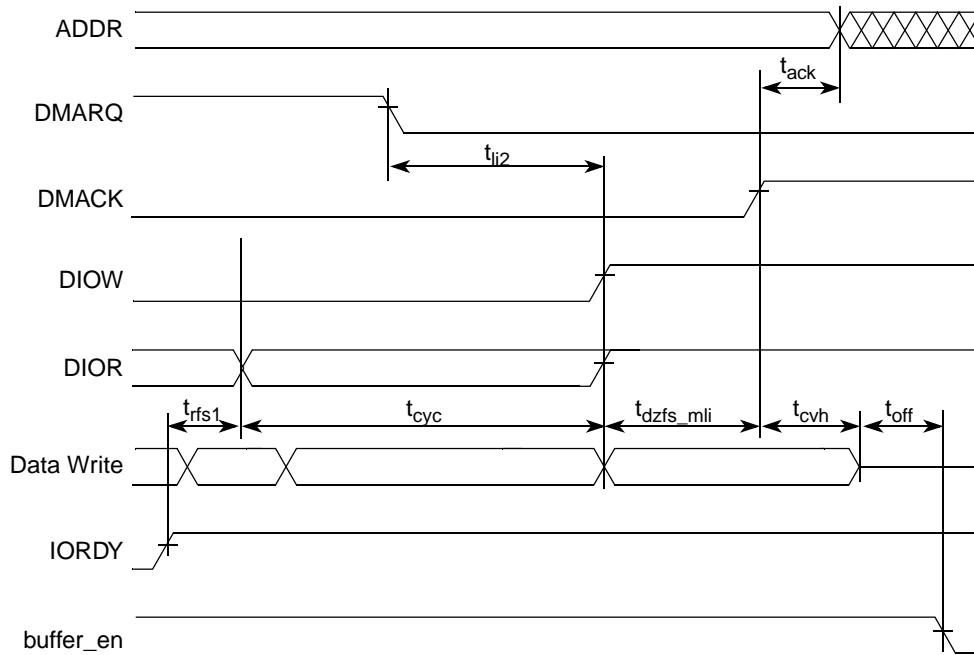

Figure 35. UDMA Out Device Terminates Transfer

Timing parameters are explained in [Table 31](#).

Table 31. Timing Parameters UDMA Out Burst

| ATA Parameter | UDMA Out Timing Parameter | Value  | How to meet                                       | SpecID |
|---------------|---------------------------|--|---|--------|
| $t_{ack}$     | $t_{ack}$                 | $t_{ack(min)} = (time\_ack \times T) - (t_{skew1} + t_{skew2})$  | calculate and program $time\_ack$ . <sup>1</sup>  | A9.63  |
| $t_{env}$     | $t_{env}$                 | $t_{env(min)} = (time\_env \times T) - (t_{skew1} + t_{skew2})$<br>$t_{env(max)} = (time\_env \times T) + (t_{skew1} + t_{skew2})$ | calculate and program $time\_env$ . <sup>1</sup>  | A9.64  |
| $t_{dvs}$     | $t_{dvs}$                 | $t_{dvs} = (time\_dvs \times T) - (t_{skew1} + t_{skew2})$   | calculate and program $time\_dvs$ . <sup>1</sup>  | A9.65  |
| $t_{dvh}$     | $t_{dvh}$                 | $t_{dvs} = (time\_dvh \times T) - (t_{skew1} + t_{skew2})$   | calculate and program $time\_dvh$ . <sup>1</sup>  | A9.66  |
| $t_{cyc}$     | $t_{cyc}$                 | $t_{cyc} = time\_cyc \times T - (t_{skew1} + t_{skew2})$   | calculate and program $time\_cyc$ . <sup>1</sup>  | A9.67  |
| $t_{2cyc}$    | —                         | $t_{2cyc} = time\_cyc \times 2 \times T$   | calculate and program $time\_cyc$ . <sup>1</sup>  | A9.68  |
| $t_{rfs1}$    | $t_{rfs1}$                | $t_{rfs1} = 1.6 \times T + t_{sui} + t_{co} + t_{buf} + t_{buf}$   | —   | A9.69  |
| —             | $t_{dzfs}$                | $t_{dzfs} = time\_dzfs \times T - (t_{skew1})$   | calculate and program $time\_dzfs$ . <sup>1</sup> | A9.70  |
| $t_{ss}$      | $t_{ss}$                  | $t_{ss} = time\_ss \times T - (t_{skew1} + t_{skew2})$   | calculate and program $time\_ss$ . <sup>1</sup>   | A9.71  |
| $t_{mli}$     | $t_{dzfs\_mli}$           | $t_{dzfs\_mli} = \max(time\_dzfs, time\_mli) \times T - (t_{skew1} + t_{skew2})$   | —   | A9.72  |
| $t_{ij}$      | $t_{ij1}$                 | $t_{ij1} > 0$  | —   | A9.73  |

Table 31. Timing Parameters UDMA Out Burst (continued)

| ATA Parameter | UDMA Out Timing Parameter           | Value  | How to meet                                  | SpecID |
|---------------|-------------------------------------|--|--|--------|
| $t_{ij}$      | $t_{ij2}$                           | $t_{ij2} > 0$  | —  | A9.74  |
| $t_{ij}$      | $t_{ij3}$                           | $t_{ij3} > 0$  | —  | A9.75  |
| $t_{cvh}$     | $t_{cvh}$                           | $t_{cvh} = (\text{time\_cvh} \times T) - (t_{\text{skew}1} + t_{\text{skew}2})$  | calculate and program time_cvh. <sup>1</sup> | A9.76  |
| —             | $t_{\text{on}}$<br>$t_{\text{off}}$ | $t_{\text{on}} = \text{time\_on} \times T - t_{\text{skew}1}$<br>$t_{\text{off}} = \text{time\_off} \times T - t_{\text{skew}1}$ | —  | A9.77  |

<sup>1</sup> See the MPC5121e Microcontroller Reference Manual.

### 3.3.10 SATA PHY

1.5 Gbps SATA PHY Layer

See “Serial ATA: High Speed Serialized AT Attachment” Revision 1.0a, 7-January-2003.

### 3.3.11 FEC

AC Test Timing Conditions:

- Output Loading  
All Outputs: 25 pF

Table 32. MII Rx Signal Timing

| Symbol | Description                            | Min | Max | Unit                       | SpecID |
|--------|--|-----|-----|----------------------------|--------|
| 1      | RXD[3:0], RX_DV, RX_ER to RX_CLK setup | 5   | —   | ns                         | A11.1  |
| 2      | RX_CLK to RXD[3:0], RX_DV, RX_ER hold  | 5   | —   | ns                         | A11.2  |
| 3      | RX_CLK pulse width high                | 35% | 65% | RX_CLK Period <sup>1</sup> | A11.3  |
| 4      | RX_CLK pulse width low                 | 35% | 65% | RX_CLK Period <sup>1</sup> | A11.4  |

<sup>1</sup> RX\_CLK shall have a frequency of 25% of data rate of the received signal. See the IEEE 802.3 Specification.

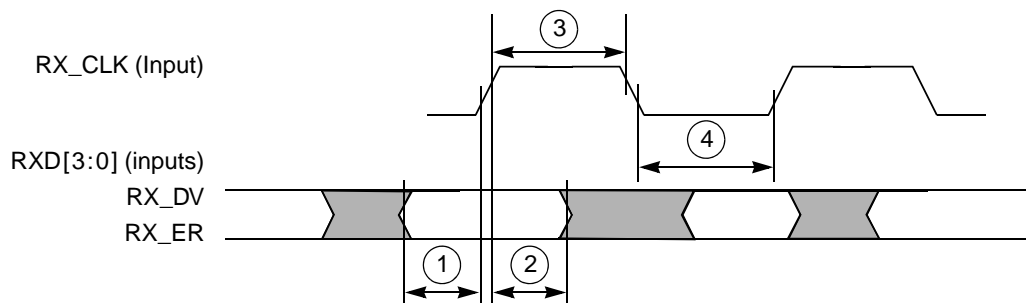
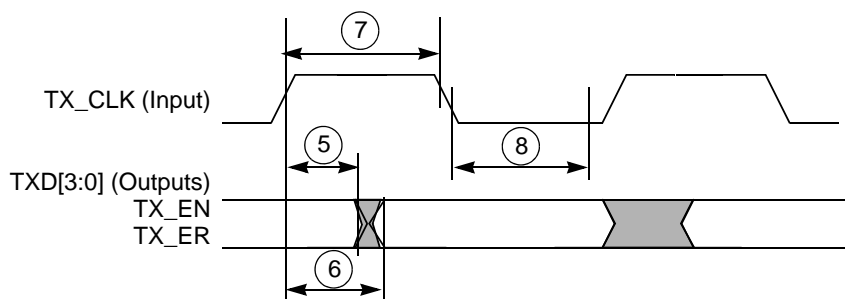

Figure 36. Ethernet Timing Diagram – MII Rx Signal

**Table 33. MII Tx Signal Timing**

| Symbol | Description  | Min | Max | Unit                       | SpecID |
|--------|--|-----|-----|----------------------------|--------|
| 5      | TX_CLK rising edge to TXD[3:0], TX_EN, TX_ER invalid | 3   | —   | ns                         | A11.5  |
| 6      | TX_CLK rising edge to TXD[3:0], TX_EN, TX_ER valid   | —   | 25  | ns                         | A11.6  |
| 7      | TX_CLK pulse width high                              | 35% | 65% | TX_CLK Period <sup>1</sup> | A11.7  |
| 8      | TX_CLK pulse width low                               | 35% | 65% | TX_CLK Period <sup>1</sup> | A11.8  |

<sup>1</sup> The TX\_CLK frequency shall be 25% of the nominal transmit frequency, e.g., a PHY operating at 100 Mb/s must provide a TX\_CLK frequency of 25 MHz and a PHY operating at 10 Mb/s must provide a TX\_CLK frequency of 2.5 MHz. See the IEEE 802.3 Specification.



**Figure 37. Ethernet Timing Diagram – MII Tx Signal**

**Table 34. MII Async Signal Timing**

| Symbol | Description                  | Min | Max | Unit          | SpecID |
|--------|------------------------------|-----|-----|---------------|--------|
| 9      | CRS, COL minimum pulse width | 1.5 | —   | TX_CLK Period | A11.9  |

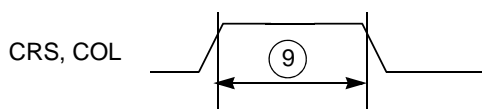

**Figure 38. Ethernet Timing Diagram – MII Async**

**Table 35. MII Serial Management Channel Signal Timing**

| Symbol | Description                           | Min | Max | Unit | SpecID |
|--------|---------------------------------------|-----|-----|------|--------|
| 10     | MDC falling edge to MDIO output delay | 0   | 25  | ns   | A11.10 |
| 11     | MDIO (input) to MDC rising edge setup | 10  | —   | ns   | A11.11 |
| 12     | MDIO (input) to MDC rising edge hold  | 0   | —   | ns   | A11.12 |
| 13     | MDC pulse width high <sup>1</sup>     | 160 | —   | ns   | A11.13 |
| 14     | MDC pulse width low <sup>1</sup>      | 160 | —   | ns   | A11.14 |
| 15     | MDC period <sup>2</sup>               | 400 | —   | ns   | A11.15 |

<sup>1</sup> MDC is generated by MPC5121e/MPC5123 with a duty cycle of 50% except when MII\_SPEED in the FEC MII\_SPEED control register is changed during operation. See the MPC5121e/MPC5123 Reference Manual.

<sup>2</sup> The MDC period must be set to a value of less than or equal to 2.5 MHz (to be compliant with the IEEE MII characteristic) by programming the FEC MII\_SPEED control register. See the MPC5121e/MPC5123 Reference Manual.

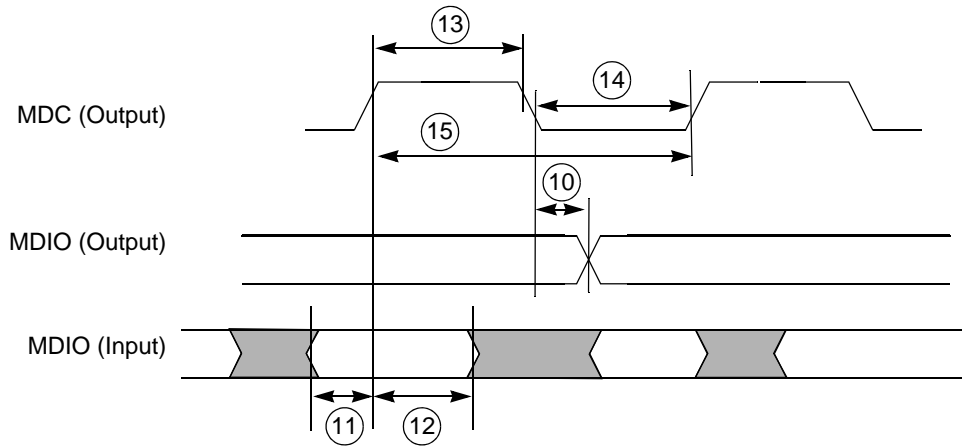

Figure 39. Ethernet Timing Diagram – MII Serial Management

### 3.3.12 USB ULPI

This section specifies the USB ULPI timing.

For more information refer to UTMI+ Low Pin Interface (ULPI) Specification, Revision 1.1, October 20, 2004.

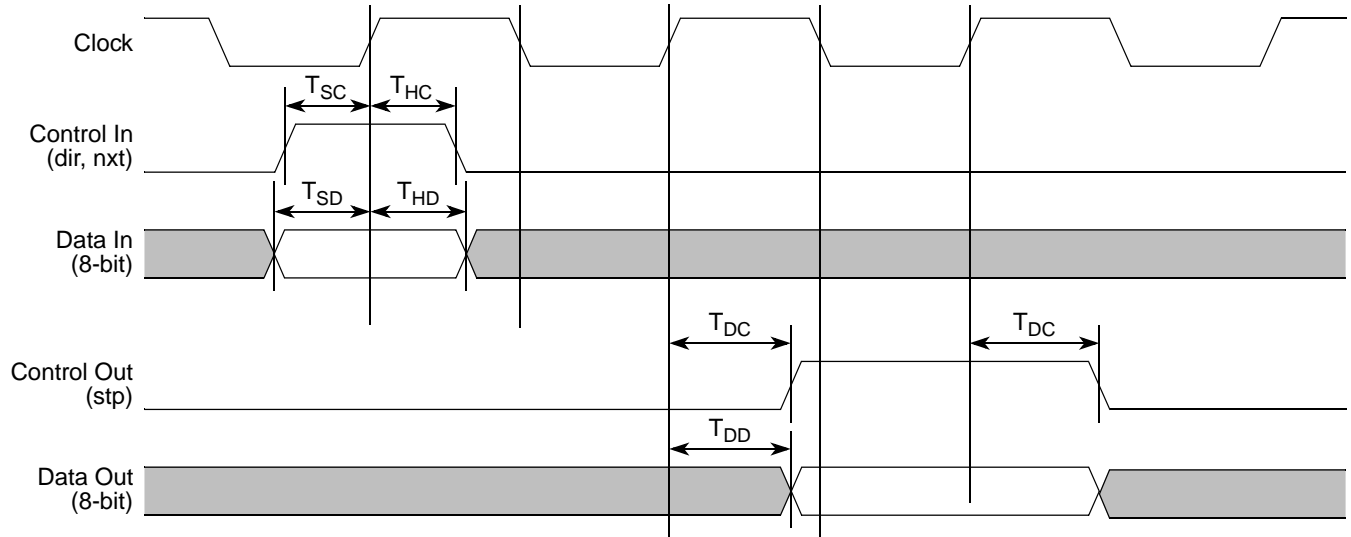

Figure 40. ULPI Timing Diagram

Table 36. Timing Specifications – ULPI

| Symbol           | Description                                | Min | Max | Units | SpecID |
|------------------|--|-----|-----|-------|--------|
| $T_{CK}$         | Clock Period                               | 15  | —   | ns    | A12.1  |
| $T_{SC}, T_{SD}$ | Setup time (control in, 8-bit data in)     | —   | 6.0 | ns    | A12.2  |
| $T_{HC}, T_{HD}$ | Hold time (control in, 8-bit data in)      | 0.0 | —   | ns    | A12.3  |
| $T_{DC}, T_{DD}$ | Output delay (control out, 8-bit data out) | —   | 9.0 | ns    | A12.4  |

**NOTE**

Output timing is specified at a nominal 50 pF load.

### 3.3.13 On-Chip USB PHY

The USB PHY is an USB2.0 compatible PHY integrated on-chip. See Chapter 7 in the USB Specification Rev. 2.0 at [www.usb.org](http://www.usb.org).

### 3.3.14 SDHC

Figure 41 shows the timings of the SDHC.

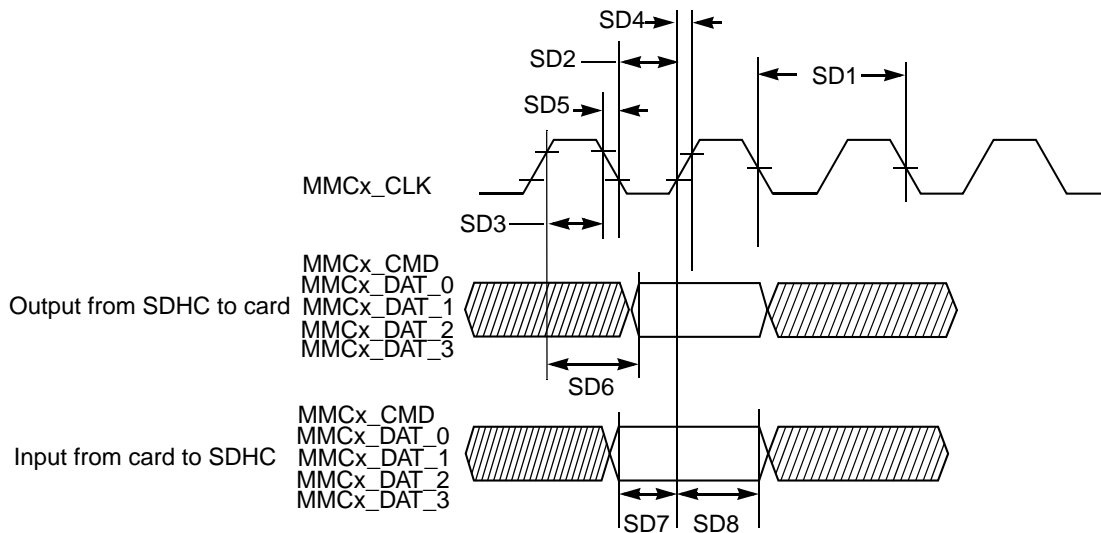

Figure 41. SDHC Timing Diagram

Table 37 lists the timing parameters.

Table 37. MMC/SD Interface Timing Parameters

| ID  | Parameter                                       | Symbols    | Min        | Max    | Unit | SpecID |
|---|---|------------|------------|--------|------|--------|
| Card Input Clock                                      |   |            |            |        |      |        |
| SD1   | Clock Frequency (Low Speed)                     | $f_{PP}^1$ | 0          | 400    | kHz  | A14.1  |
|   | Clock Frequency (SD/SDIO Full Speed/High Speed) | $f_{PP}^2$ | 0          | 25/50  | MHz  | A14.2  |
|   | Clock Frequency (MMC Full Speed/High Speed)     | $f_{PP}^3$ | 0          | 20/52  | MHz  | A14.3  |
|   | Clock Frequency (Identification Mode)           | $f_{OD}^4$ | 100        | 400    | kHz  | A14.4  |
| SD2   | Clock Low Time (Full Speed/High Speed)          | $t_{WL}$   | 10/7       |        | ns   | A14.5  |
| SD3   | Clock High Time (Full Speed/High Speed)         | $t_{WH}$   | 10/7       |        | ns   | A14.6  |
| SD4   | Clock Rise Time (Full Speed/High Speed)         | $t_{TLH}$  |            | 10/3   | ns   | A14.7  |
| SD5   | Clock Fall Time (Full Speed/High Speed)         | $t_{THL}$  |            | 10/3   | ns   | A14.8  |
| SDHC Output / Card Inputs CMD, DAT (Reference to CLK) |   |            |            |        |      |        |
| SD6   | SDHC Output Delay                               | $t_{OD}$   | $TH^5 - 3$ | $TH+3$ | ns   | A14.9  |
| SDHC Input / Card Outputs CMD, DAT (Reference to CLK) |   |            |            |        |      |        |
| SD7   | SDHC Input Setup Time                           | $t_{ISU}$  | 2.5        |        | ns   | A14.10 |
| SD8   | SDHC Input Hold Time                            | $t_{IH}$   | 2.5        |        | ns   | A14.11 |

<sup>1</sup> In low speed mode, card clock must be lower than 400 kHz, voltage ranges from 2.7 to 3.6 V.

<sup>2</sup> In normal data transfer mode for SD/SDIO card, clock frequency can be any value between 0 ~ 25 MHz.

<sup>3</sup> In normal data transfer mode for MMC card, clock frequency can be any value between 0 ~ 20 MHz.

<sup>4</sup> In card identification mode, card clock must be 100 kHz ~ 400 kHz, voltage ranges from 2.7 to 3.6 V.

<sup>5</sup> Suggested ClockPeriod = T, CLK\_DIVIDER (in SDHC Clock Rate Register) = D, then  $TH = [(D + 1)/2]/(D + 1) \times T$  where the value is rounded.

### 3.3.15 DIU

The DIU is a display controller designed to manage the TFT LCD display.

#### 3.3.15.1 Interface to TFT LCD Panels, Functional Description

Figure 42 shows the LCD interface timing for a generic active matrix color TFT panel. In this figure signals are shown with positive polarity. The sequence of events for active matrix interface timing is:

- DIU\_CLK latches data into the panel on its positive edge (when positive polarity is selected). In active mode, DIU\_CLK runs continuously. This signal frequency could be from 5 to 100 MHz depending on the panel type.
- DIU\_HSYNC causes the panel to start a new line. It always encompasses at least one DIU\_CLK pulse.
- DIU\_VSYNC causes the panel to start a new frame. It always encompasses at least one DIU\_HSYNC pulse.
- DIU\_DE acts like an output enable signal to the LCD panel. This output enables the data to be shifted onto the display. When disabled, the data is invalid and the trace is off.

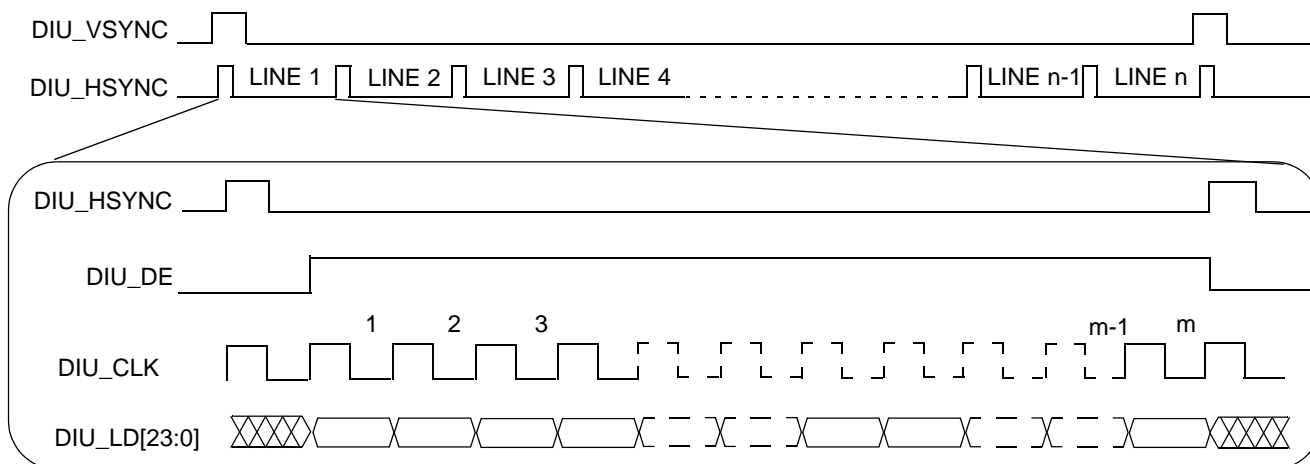
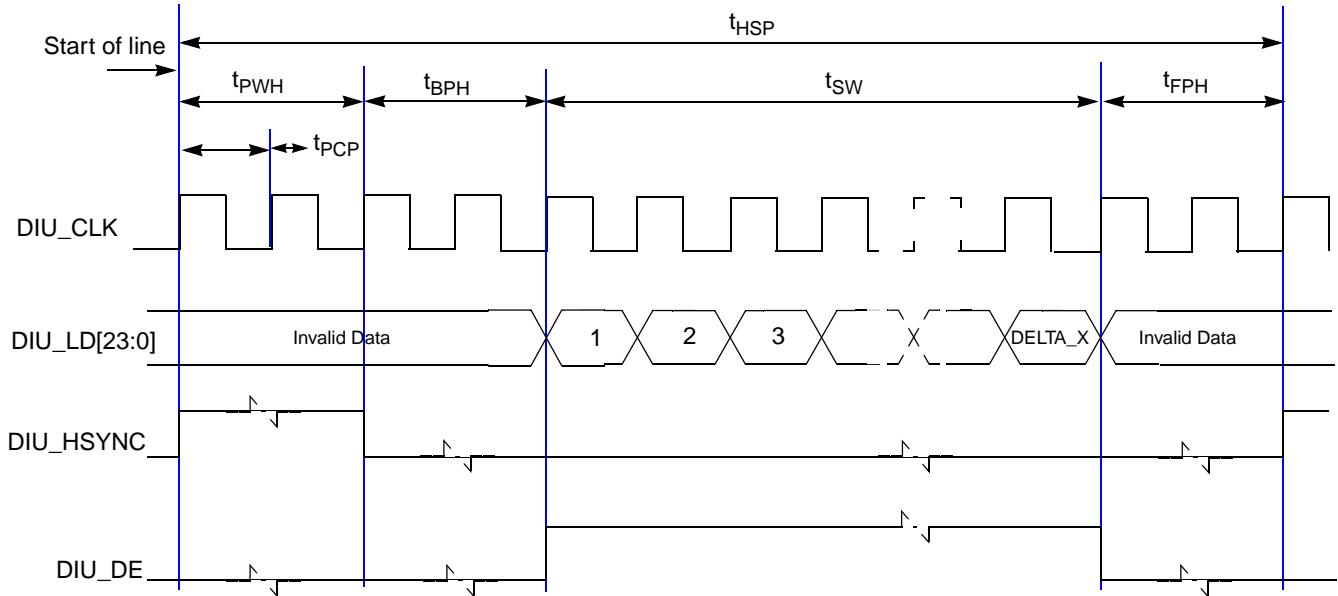

Figure 42. Interface Timing Diagram for TFT LCD Panels

#### 3.3.15.2 Interface to TFT LCD Panels, Electrical Characteristics

Figure 43 shows the horizontal timing (timing of one line), including the horizontal sync pulse and the data. All parameters shown in the diagram are programmable. This timing diagram corresponds to positive polarity of the DIU\_CLK signal (meaning the data and sync. signals change at the rising edge of it) and active-high polarity of the DIU\_HSYNC, DIU\_VSYNC and DIU\_DE signal. You can select the polarity of the DIU\_HSYNC and DIU\_VSYNC signal via the SYN\_POL register, whether active-high or active-low, the default is active-high. The DIU\_DE signal is always active-high. And, pixel clock inversion and a flexible programmable pixel clock delay is also supported, programmed via the DIU Clock Config Register (DCCR) in the system clock module.





**Figure 43. TFT LCD Interface Timing Diagram – Horizontal Sync Pulse**

Figure 44 shows the vertical timing (timing of one frame), including the vertical sync pulse and the data. All parameters shown in the diagram are programmable.

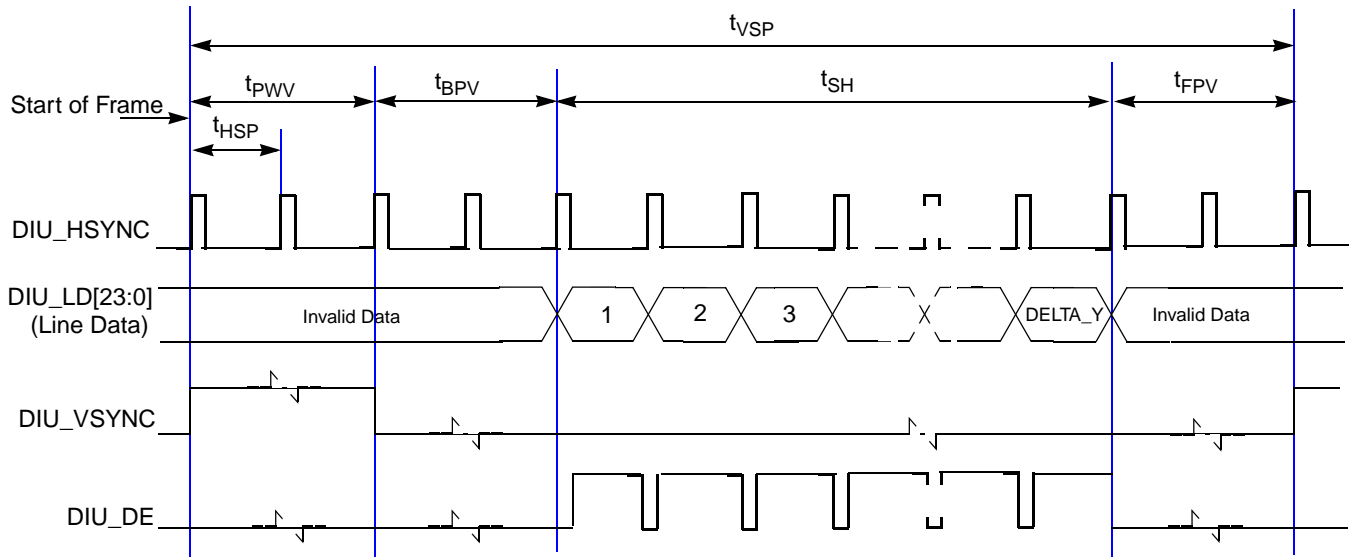

**Figure 44. TFT LCD Interface Timing Diagram – Vertical Sync Pulse**

Table 38 shows timing parameters of signals.

**Table 38. LCD Interface Timing Parameters – Pixel Level**

| Name      | Description                | Value                  | Unit | SpecID |
|-----------|----------------------------|------------------------|------|--------|
| $t_{PCP}$ | Display Pixel Clock Period | $15^1$                 | ns   | A15.1  |
| $t_{PWH}$ | HSYNC Pulse Width          | $PW\_H \times t_{PCP}$ | ns   | A15.2  |
| $t_{BPH}$ | HSYNC Back Porch Width     | $BP\_H \times t_{PCP}$ | ns   | A15.3  |

**Table 38. LCD Interface Timing Parameters – Pixel Level (continued)**

| Name      | Description             | Value   | Unit | SpecID |
|-----------|-------------------------|---|------|--------|
| $t_{FPH}$ | HSYNC Front Porch Width | $FP\_H \times t_{PCP}$                              | ns   | A15.4  |
| $t_{SW}$  | Screen Width            | $DELTA\_X \times t_{PCP}$                           | ns   | A15.5  |
| $t_{HSP}$ | HSYNC (Line) Period     | $(PW\_H + BP\_H + DELTA\_X + FP\_H) \times t_{PCP}$ | ns   | A15.6  |
| $t_{PWV}$ | VSYNC Pulse Width       | $PW\_V \times t_{HSP}$                              | ns   | A15.7  |
| $t_{BPV}$ | VSYNC Back Porch Width  | $BP\_V \times t_{HSP}$                              | ns   | A15.8  |
| $t_{FPV}$ | VSYNC Front Porch Width | $FP\_V \times t_{HSP}$                              | ns   | A15.9  |
| $t_{SH}$  | Screen Height           | $DELTA\_Y \times t_{HSP}$                           | ns   | A15.10 |
| $t_{VSP}$ | VSYNC (Frame) Period    | $(PW\_V + BP\_V + DELTA\_Y + FP\_H) \times t_{HSP}$ | ns   | A15.11 |

<sup>1</sup> Display interface pixel clock period immediate value (in nanosecond).

The DELTA\_X and DELTA\_Y parameters are programmed via the DISP\_SIZE register; The PW\_H, BP\_H, and FP\_H parameters are programmed via the HSYN\_PARA register; And the PW\_V, BP\_V and FP\_V parameters are programmed via the VSYN\_PARA register. See appropriate section in the reference manual for detailed descriptions on these parameters.

Figure 45 shows the synchronous display interface timing for access level, and Table 39 lists the timing parameters.

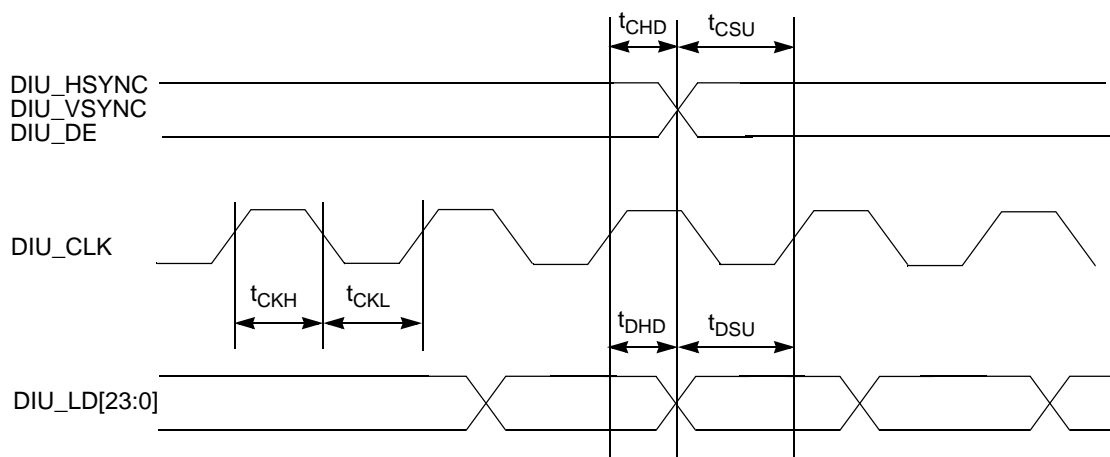

**Figure 45. LCD Interface Timing Diagram – Access Level**

**Table 39. LCD Interface Timing Parameters – Access Level**

| Parameter | Description                             | Min                  | Typ                  | Max                  | Unit | SpecID |
|-----------|---|----------------------|----------------------|----------------------|------|--------|
| $t_{CKH}$ | LCD Interface Pixel Clock High Time     | $t_{PCP} \times 0.4$ | $t_{PCP} \times 0.5$ | $t_{PCP} \times 0.6$ | ns   | A15.12 |
| $t_{CKL}$ | LCD Interface Pixel Clock Low Time      | $t_{PCP} \times 0.4$ | $t_{PCP} \times 0.5$ | $t_{PCP} \times 0.6$ | ns   | A15.13 |
| $t_{DSU}$ | LCD Interface Data Setup Time           | 5.0                  | —                    | —                    | ns   | A15.14 |
| $t_{DHD}$ | LCD Interface Data Hold Time            | 6.0                  | —                    | —                    | ns   | A15.15 |
| $t_{CSU}$ | LCD Interface Control Signal Setup Time | 5.0                  | —                    | —                    | ns   | A15.16 |
| $t_{CHD}$ | LCD Interface Control Signal Hold Time  | 6.0                  | —                    | —                    | ns   | A15.17 |

### 3.3.16 SPDIF

The Sony/Philips Digital Interface (SPDIF) timing is totally asynchronous, therefore there is no need for relationship with the clock.

### 3.3.17 CAN

The CAN functions are available as TX and CAN3/4\_RX pins at normal IO pads and as CAN1/2 RX pins at the VBAT\_RTC domain. There is no filter for the WakeUp dominant pulse. Any High-to-Low edge can cause WakeUp, if configured.

### 3.3.18 I<sup>2</sup>C

This section specifies the timing parameters of the Inter-Integrated Circuit (I<sup>2</sup>C) interface. Refer to the I<sup>2</sup>C Bus Specification.

**Table 40. I<sup>2</sup>C Input Timing Specifications – SCL and SDA**

| Symbol | Description  | Min | Max | Units                     | SpecID |
|--------|--|-----|-----|---------------------------|--------|
| 1      | Start condition hold time                                      | 2   | —   | IP-Bus Cycle <sup>1</sup> | A18.1  |
| 2      | Clock low time   | 8   | —   | IP-Bus Cycle <sup>1</sup> | A18.2  |
| 4      | Data hold time   | 0.0 | —   | ns                        | A18.3  |
| 6      | Clock high time  | 4   | —   | IP-Bus Cycle <sup>1</sup> | A18.4  |
| 7      | Data setup time  | 0.0 | —   | ns                        | A18.5  |
| 8      | Start condition setup time (for repeated start condition only) | 2   | —   | IP-Bus Cycle <sup>1</sup> | A18.6  |
| 9      | Stop condition setup time                                      | 2   | —   | IP-Bus Cycle <sup>1</sup> | A18.7  |

<sup>1</sup> Inter Peripheral Clock is defined in the MPC5121e/MPC5123 *Reference Manual*.

**Table 41. I<sup>2</sup>C Output Timing Specifications – SCL and SDA**

| Symbol         | Description  | Min | Max | Units                     | SpecID |
|----------------|--|-----|-----|---------------------------|--------|
| 1 <sup>1</sup> | Start condition hold time                                      | 6   | —   | IP-Bus Cycle <sup>2</sup> | A18.8  |
| 2 <sup>1</sup> | Clock low time   | 10  | —   | IP-Bus Cycle <sup>2</sup> | A18.9  |
| 3 <sup>3</sup> | SCL/SDA rise time  | —   | 7.9 | ns                        | A18.10 |
| 4 <sup>1</sup> | Data hold time   | 7   | —   | IP-Bus Cycle <sup>2</sup> | A18.11 |
| 5 <sup>1</sup> | SCL/SDA fall time  | —   | 7.9 | ns                        | A18.12 |
| 6 <sup>1</sup> | Clock high time  | 10  | —   | IP-Bus Cycle <sup>2</sup> | A18.13 |
| 7 <sup>1</sup> | Data setup time  | 2   | —   | IP-Bus Cycle <sup>2</sup> | A18.14 |
| 8 <sup>1</sup> | Start condition setup time (for repeated start condition only) | 20  | —   | IP-Bus Cycle <sup>2</sup> | A18.15 |
| 9 <sup>1</sup> | Stop condition setup time                                      | 10  | —   | IP-Bus Cycle <sup>2</sup> | A18.16 |

<sup>1</sup> Programming IFDR with the maximum frequency results in the minimum output timings listed. The I<sup>2</sup>C interface is designed to scale the data transition time, moving it to the middle of the SCL low period. The actual position is affected by the prescale and division values programmed in IFDR.

<sup>2</sup> Because SCL and SDA are open-drain-type outputs, which the processor can only actively drive low, the time SCL or SDA takes to reach a high level depends on external signal capacitance and pull-up resistor values.

<sup>3</sup> Inter Peripheral Clock is defined in the MPC5121e/MPC5123 *Reference Manual*.

**NOTE**

Output timing is specified at a nominal 50 pF load.

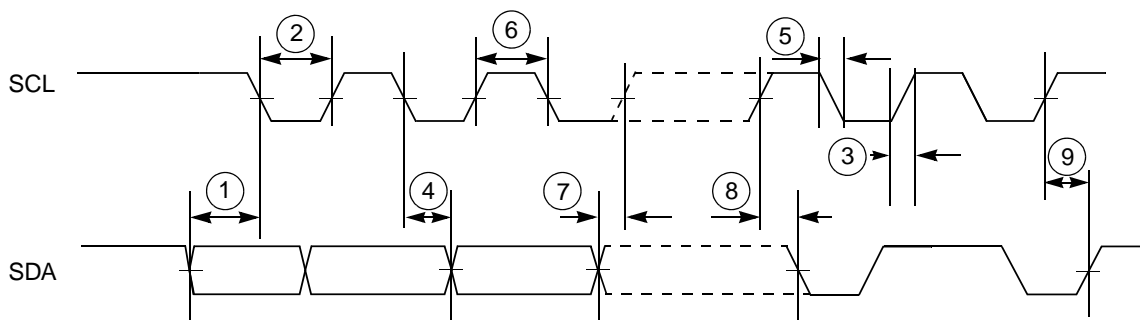

**Figure 46. Timing Diagram – I<sup>2</sup>C Input/Output**

**3.3.19 J1850**

See the MPC5121e/MPC5123 Reference Manual.

**3.3.20 PSC**

The Programmable Serial Controllers (PSC) support different modes of operation (UART, Codec, AC97, SPI). UART is an asynchronous interface, there is no AC characteristic.

**3.3.20.1 Codec Mode (8,16,24 and 32-bit)/I<sup>2</sup>S Mode**

**Table 42. Timing Specifications – 8,16, 24, and 32-bit CODEC/I<sup>2</sup>S Master Mode**

| Symbol | Description                                      | Min  | Typ | Max | Units          | SpecID |
|--------|--|------|-----|-----|----------------|--------|
| 1      | Bit Clock cycle time, programmed in CCS register | 40.0 | —   | —   | ns             | A20.1  |
| 2      | Clock duty cycle                                 | 45   | 50  | 55  | % <sup>1</sup> | A20.2  |
| 3      | Bit Clock fall time                              | —    | —   | 7.9 | ns             | A20.3  |
| 4      | Bit Clock rise time                              | —    | —   | 7.9 | ns             | A20.4  |
| 5      | FrameSync valid after clock edge                 | —    | —   | 8.4 | ns             | A20.5  |
| 6      | FrameSync invalid after clock edge               | —    | —   | 8.4 | ns             | A20.6  |
| 7      | Output Data valid after clock edge               | —    | —   | 9.3 | ns             | A20.7  |
| 8      | Input Data setup time                            | 6.0  | —   | —   | ns             | A20.8  |

<sup>1</sup> Bit Clock cycle time

**NOTE**

Output timing is specified at a nominal 50 pF load.

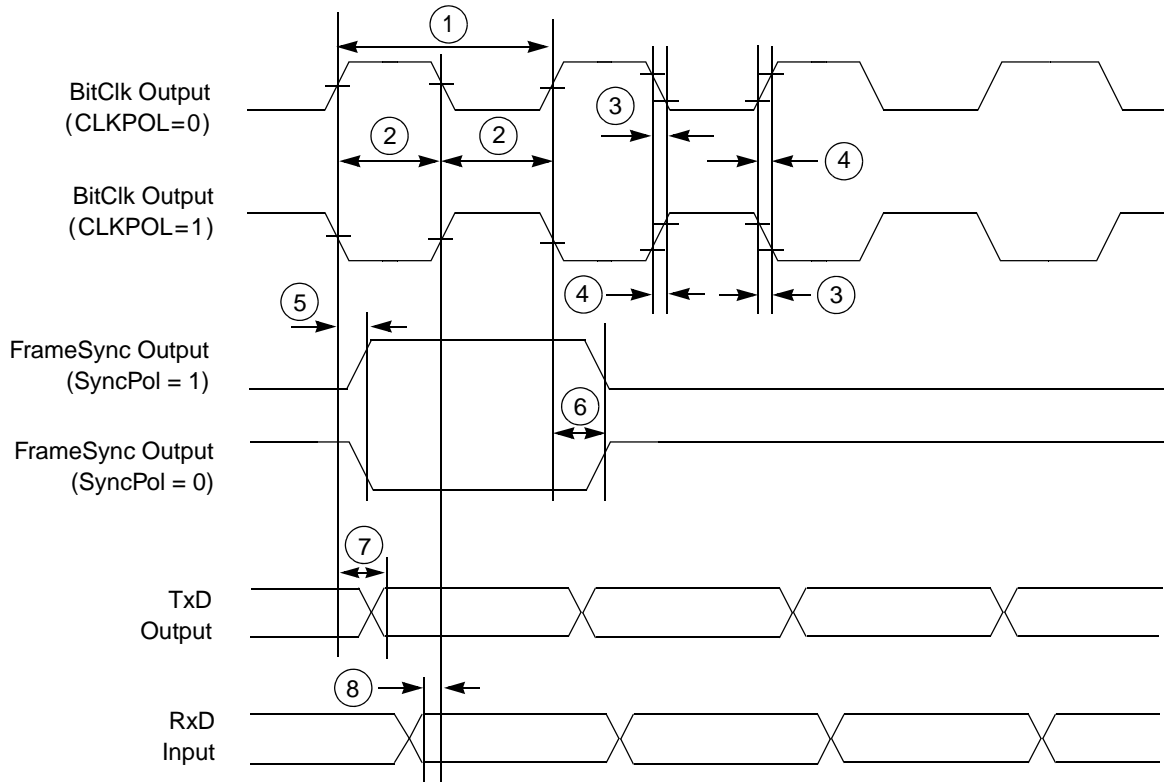
**Figure 47. Timing Diagram – 8, 16, 24, and 32-bit CODEC/I<sup>2</sup>S Master Mode**
**Table 43. Timing Specifications – 8, 16, 24, and 32-bit CODEC/I<sup>2</sup>S Slave Mode**

| Symbol | Description                        | Min  | Typ | Max  | Units          | SpecID |
|--------|------------------------------------|------|-----|------|----------------|--------|
| 1      | Bit Clock cycle time               | 40.0 | —   | —    | ns             | A20.9  |
| 2      | Clock duty cycle                   | —    | 50  | —    | % <sup>1</sup> | A20.10 |
| 3      | FrameSync setup time               | 1.0  | —   | —    | ns             | A20.11 |
| 4      | Output Data valid after clock edge | —    | —   | 14.0 | ns             | A20.12 |
| 5      | Input Data setup time              | 1.0  | —   | —    | ns             | A20.13 |
| 6      | Input Data hold time               | 1.0  | —   | —    | ns             | A20.14 |

<sup>1</sup> Bit Clock cycle time

### NOTE

Output timing is specified at a nominal 50 pF load.

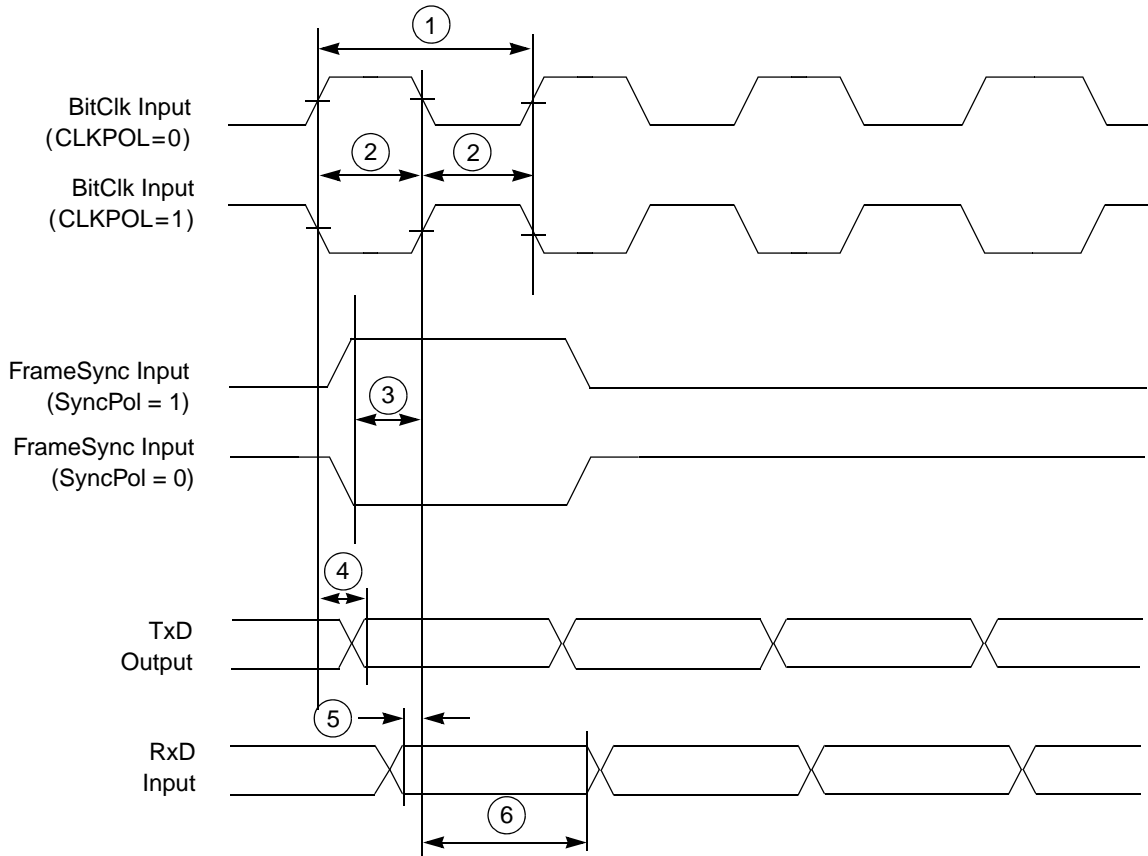

Figure 48. Timing Diagram – 8,16, 24, and 32-bit CODEC/I<sup>2</sup>S Slave Mode

### 3.3.20.2 AC97 Mode

Table 44. Timing Specifications – AC97 Mode

| Symbol | Description                               | Min | Typ  | Max  | Units | SpecID |
|--------|---|-----|------|------|-------|--------|
| 1      | Bit Clock cycle time                      | —   | 81.4 | —    | ns    | A20.15 |
| 2      | Clock pulse high time                     | —   | 40.7 | —    | ns    | A20.16 |
| 3      | Clock pulse low time                      | —   | 40.7 | —    | ns    | A20.17 |
| 4      | FrameSync valid after rising clock edge   | —   | —    | 13.0 | ns    | A20.18 |
| 5      | Output Data valid after rising clock edge | —   | —    | 14.0 | ns    | A20.19 |
| 6      | Input Data setup time                     | 1.0 | —    | —    | ns    | A20.20 |
| 7      | Input Data hold time                      | 1.0 | —    | —    | ns    | A20.21 |

**NOTE**

Output timing is specified at a nominal 50 pF load.

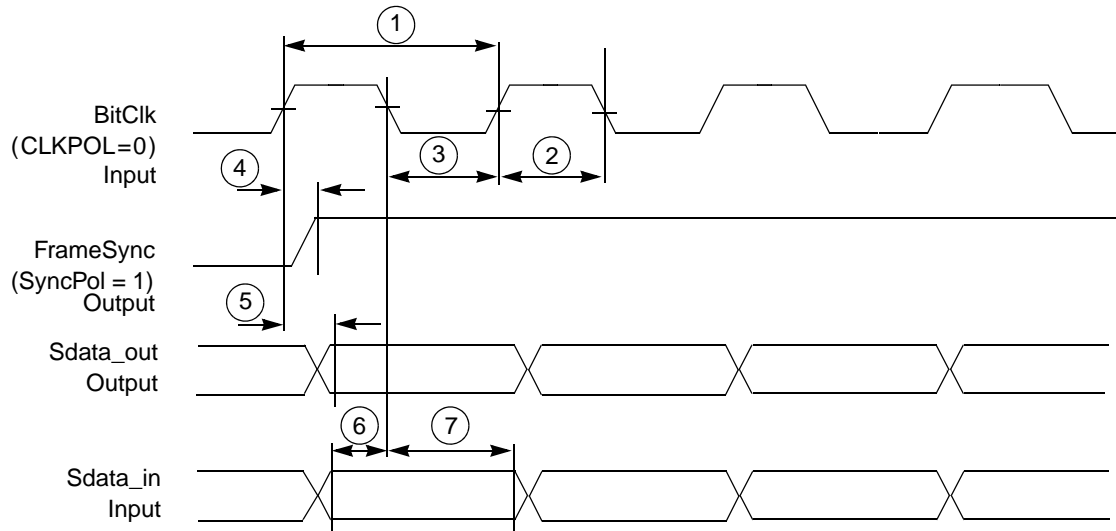

Figure 49. Timing Diagram – AC97 Mode

### 3.3.20.3 SPI Mode

Table 45. Timing Specifications – SPI Master Mode, Format 0 (CPHA = 0)

| Symbol | Description   | Min  | Max              | Units | SpecID |
|--------|---|------|------------------|-------|--------|
| 1      | SCK cycle time, programmable in the PSC CCS register                    | 30.0 | —                | ns    | A20.26 |
| 2      | SCK pulse width, 50% SCK duty cycle                                     | 15.0 | —                | ns    | A20.27 |
| 3      | Slave select clock delay, programmable in the PSC CCS register          | 30.0 | —                | ns    | A20.28 |
| 4      | Output Data valid after Slave Select ( $\overline{SS}$ )                | —    | 8.9              | ns    | A20.29 |
| 5      | Output Data valid after SCK   | —    | 8.9              | ns    | A20.30 |
| 6      | Input Data setup time   | 6.0  | —                | ns    | A20.31 |
| 7      | Input Data hold time  | 1.0  | —                | ns    | A20.32 |
| 8      | Slave disable lag time  | —    | T <sub>SCK</sub> | ns    | A20.33 |
| 9      | Sequential Transfer delay, programmable in the PSC CTUR / CTLR register | 15.0 | —                | ns    | A20.34 |
| 10     | Clock falling time  | —    | 7.9              | ns    | A20.35 |
| 11     | Clock rising time   | —    | 7.9              | ns    | A20.36 |

#### NOTE

Output timing is specified at a nominal 50 pF load.

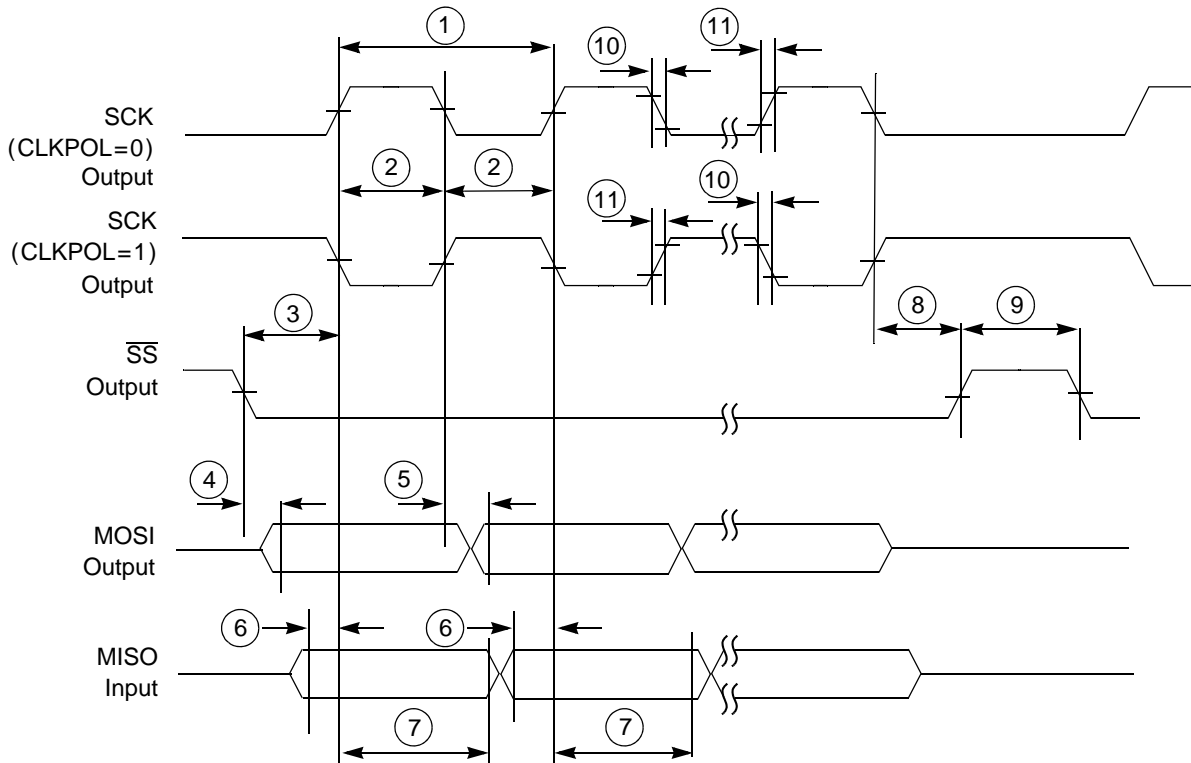

Figure 50. Timing Diagram – SPI Master Mode, Format 0 (CPHA = 0)

Table 46. Timing Specifications – SPI Slave Mode, Format 0 (CPHA = 0)

| Symbol | Description   | Min  | Max  | Units | SpecID |
|--------|---|------|------|-------|--------|
| 1      | SCK cycle time, programmable in the PSC CCS register            | 30.0 | —    | ns    | A20.37 |
| 2      | SCK pulse width, 50% SCK duty cycle                             | 15.0 | —    | ns    | A20.38 |
| 3      | Slave select clock delay  | 1.0  | —    | ns    | A20.39 |
| 4      | Input Data setup time   | 1.0  | —    | ns    | A20.40 |
| 5      | Input Data hold time  | 1.0  | —    | ns    | A20.41 |
| 6      | Output data valid after $\overline{SS}$                         | —    | 14.0 | ns    | A20.42 |
| 7      | Output data valid after SCK                                     | —    | 14.0 | ns    | A20.43 |
| 8      | Slave disable lag time  | 0.0  | —    | ns    | A20.44 |
| 9      | Minimum Sequential Transfer delay = 2 × IP Bus clock cycle time | 30.0 | —    | —     | A20.45 |

**NOTE**

Output timing is specified at a nominal 50 pF load.



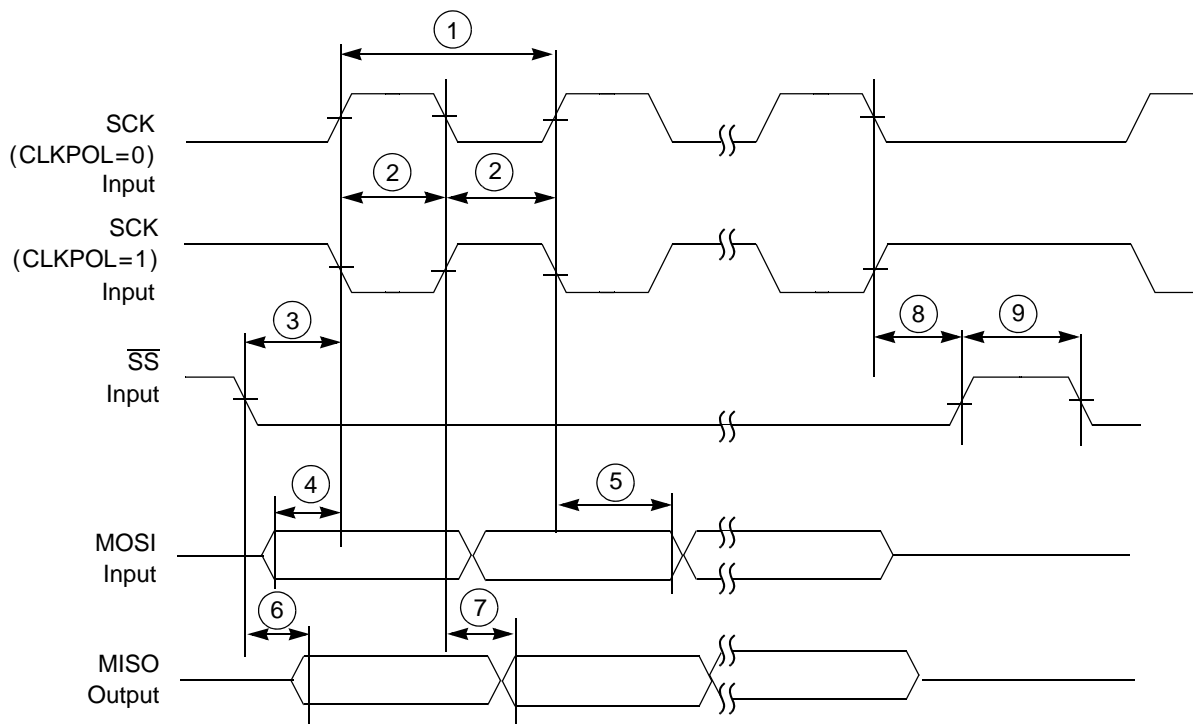

Figure 51. Timing Diagram – SPI Slave Mode, Format 0 (CPHA = 0)

Table 47. Timing Specifications – SPI Master Mode, Format 1 (CPHA = 1)

| Symbol | Description   | Min  | Max              | Units | SpecID |
|--------|---|------|------------------|-------|--------|
| 1      | SCK cycle time, programmable in the PSC CCS register                    | 30.0 | —                | ns    | A20.46 |
| 2      | SCK pulse width, 50% SCK duty cycle                                     | 15.0 | —                | ns    | A20.47 |
| 3      | Slave select clock delay, programmable in the PSC CCS register          | 30.0 | —                | ns    | A20.48 |
| 4      | Output data valid   | —    | 8.9              | ns    | A20.49 |
| 5      | Input Data setup time   | 6.0  | —                | ns    | A20.50 |
| 6      | Input Data hold time  | 1.0  | —                | ns    | A20.51 |
| 7      | Slave disable lag time  | —    | T <sub>SCK</sub> | ns    | A20.52 |
| 8      | Sequential Transfer delay, programmable in the PSC CTUR / CTLR register | 15.0 | —                | ns    | A20.53 |
| 9      | Clock falling time  | —    | 7.9              | ns    | A20.54 |
| 10     | Clock rising time   | —    | 7.9              | ns    | A20.55 |

**NOTE**

Output timing is specified at a nominal 50 pF load.

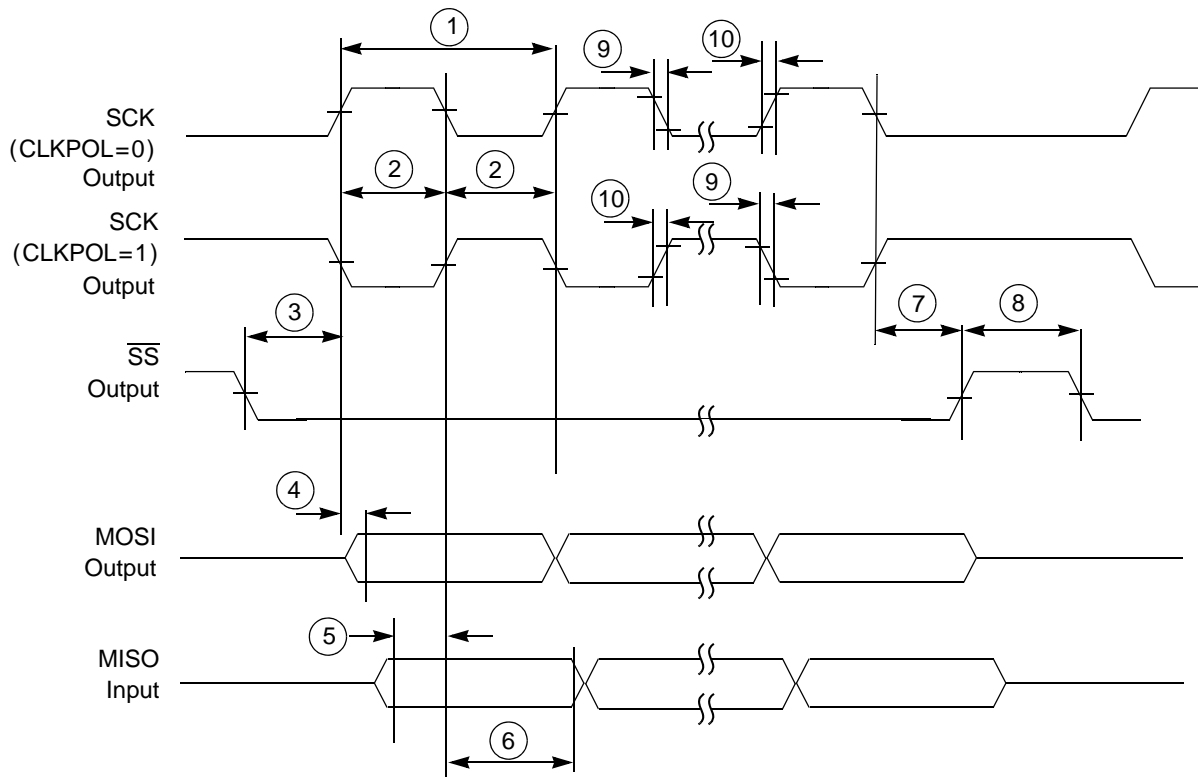

Figure 52. Timing Diagram – SPI Master Mode, Format 1 (CPHA = 1)

Table 48. Timing Specifications – SPI Slave Mode, Format 1 (CPHA = 1)

| Symbol | Description   | Min  | Max  | Units | SpecID |
|--------|---|------|------|-------|--------|
| 1      | SCK cycle time, programmable in the PSC CCS register            | 30.0 | —    | ns    | A20.56 |
| 2      | SCK pulse width, 50% SCK duty cycle                             | 15.0 | —    | ns    | A20.57 |
| 3      | Slave select clock delay  | 0.0  | —    | ns    | A20.58 |
| 4      | Output data valid   | —    | 14.0 | ns    | A20.59 |
| 5      | Input Data setup time   | 2.0  | —    | ns    | A20.60 |
| 6      | Input Data hold time  | 1.0  | —    | ns    | A20.61 |
| 7      | Slave disable lag time  | 0.0  | —    | ns    | A20.62 |
| 8      | Minimum Sequential Transfer delay = 2 × IP-Bus clock cycle time | 30.0 | —    | ns    | A20.63 |

**NOTE**

Output timing is specified at a nominal 50 pF load.

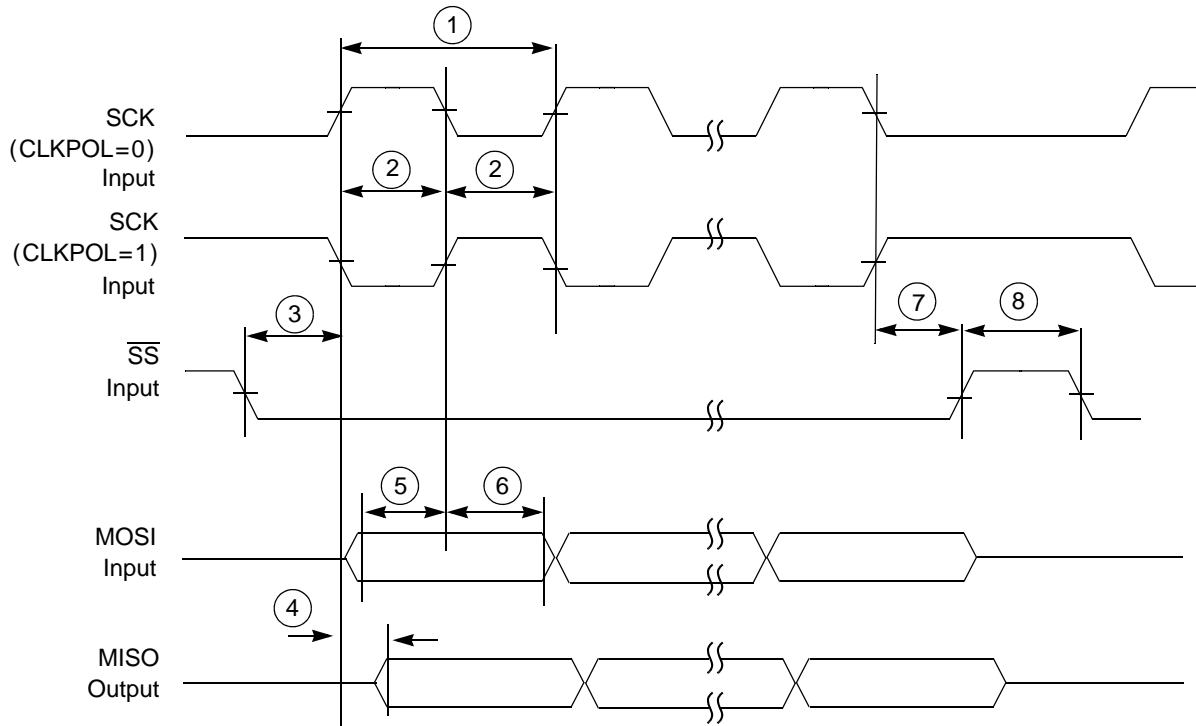

Figure 53. Timing Diagram – SPI Slave Mode, Format 1 (CPHA = 1)

### 3.3.21 GPIOs and Timers

The MPC5121e/MPC5123 contains several sets of I/Os that do not require special setup, hold, or valid requirements. The external events (GPIO or timer inputs) are asynchronous to the system clock. The inputs must be valid for at least  $t_{IOWID}$  to ensure proper capture by the internal IP clock.

**Table 49. GPIO/Timers Input AC Timing Specifications**

| Symbol      | Description                            | Min    | Unit | SpecID |
|-------------|--|--------|------|--------|
| $t_{IOWID}$ | GPIO/Timers inputs—minimum pulse width | $2T^1$ | ns   | A21.1  |

<sup>1</sup> T is the IP bus clock cycle. T = 12 ns is the minimum value (for the maximum IP bus frequency of 83 MHz).

### 3.3.22 Fusebox

Table 50 gives the Fusebox specification.

**Table 50. Fusebox Characteristics**

| Symbol       | Description                             | Min | Max | Units | SpecID |
|--------------|---|-----|-----|-------|--------|
| $t_{FUSEWR}$ | Program time <sup>1</sup> for Fuse      | 125 | —   | us    | A22.1  |
| $I_{FUSEWR}$ | Program current to program one fuse bit | —   | 10  | mA    | A22.2  |

<sup>1</sup> The program length is defined by the value defined in the EPM\_PGM\_LENGTH bits of the IIM module.

### 3.3.23 IEEE 1149.1 (JTAG)

Table 51. JTAG Timing Specification

| Symbol | Characteristic   | Min  | Max | Unit | SpecID |
|--------|--|------|-----|------|--------|
| —      | TCK frequency of operation   | 0    | 25  | MHz  | A23.1  |
| 1      | TCK cycle time   | 40   | —   | ns   | A23.2  |
| 2      | TCK clock pulse width measured at 1.5V                               | 1.08 | —   | ns   | A23.3  |
| 3      | TCK rise and fall times  | 0    | 3   | ns   | A23.4  |
| 4      | $\overline{\text{TRST}}$ setup time to tck falling edge <sup>1</sup> | 10   | —   | ns   | A23.5  |
| 5      | $\overline{\text{TRST}}$ assert time                                 | 5    | —   | ns   | A23.6  |
| 6      | Input data setup time <sup>2</sup>                                   | 5    | —   | ns   | A23.7  |
| 7      | Input data hold time <sup>2</sup>                                    | 15   | —   | ns   | A23.8  |
| 8      | TCK to output data valid <sup>3</sup>                                | 0    | 30  | ns   | A23.9  |
| 9      | TCK to output high impedance <sup>3</sup>                            | 0    | 30  | ns   | A23.10 |
| 10     | TMS, TDI data setup time.  | 5    | —   | ns   | A23.11 |
| 11     | TMS, TDI data hold time.   | 1    | —   | ns   | A23.12 |
| 12     | TCK to TDO data valid.   | 0    | 15  | ns   | A23.13 |
| 13     | TCK to TDO high impedance.   | 0    | 15  | ns   | A23.14 |

<sup>1</sup>  $\overline{\text{TRST}}$  is an asynchronous signal. The setup time is for test purposes only.

<sup>2</sup> Non-test, other than TDI and TMS, signal input timing with respect to TCK.

<sup>3</sup> Non-test, other than TDO, signal output timing with respect to TCK.

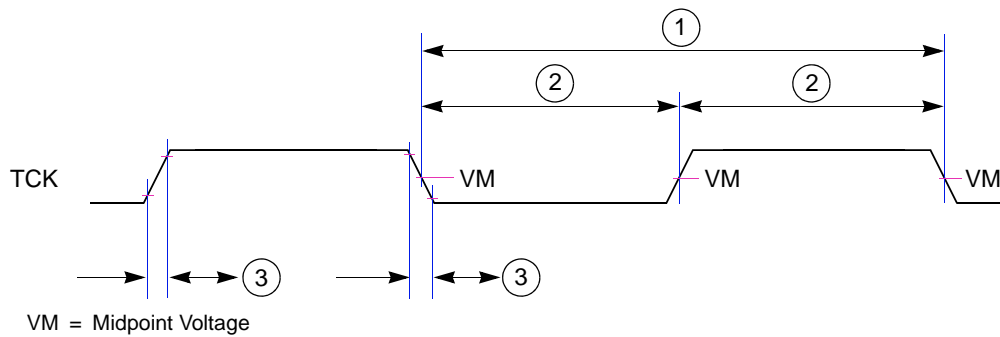

Figure 54. Timing Diagram – JTAG Clock Input

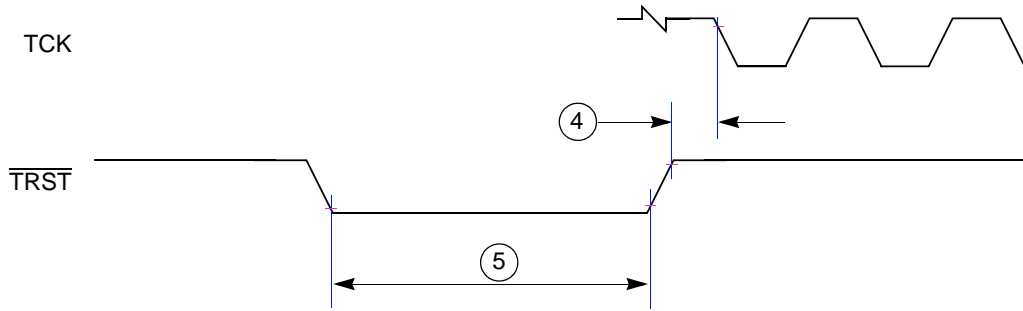

Figure 55. Timing Diagram – JTAG TRST

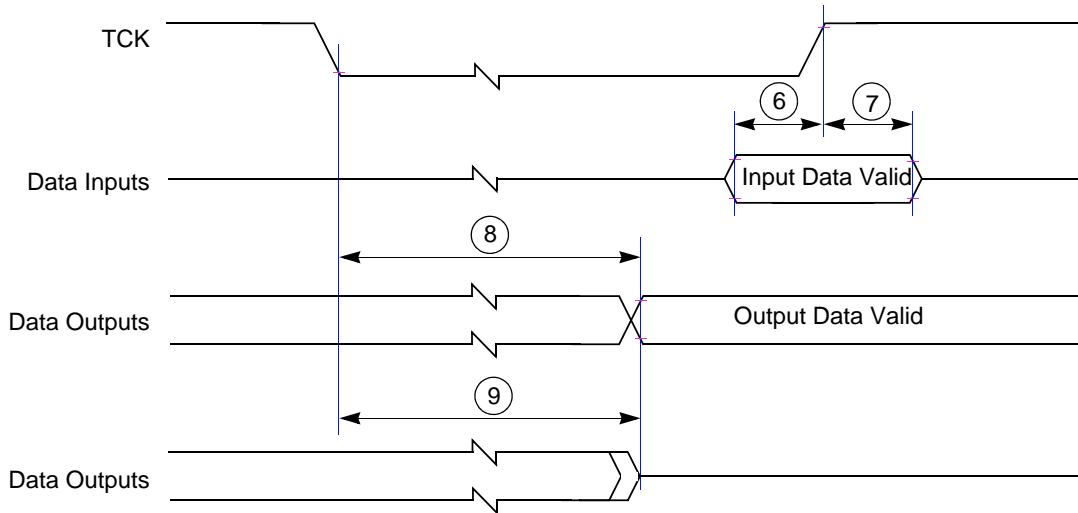

Figure 56. Timing Diagram – JTAG Boundary Scan

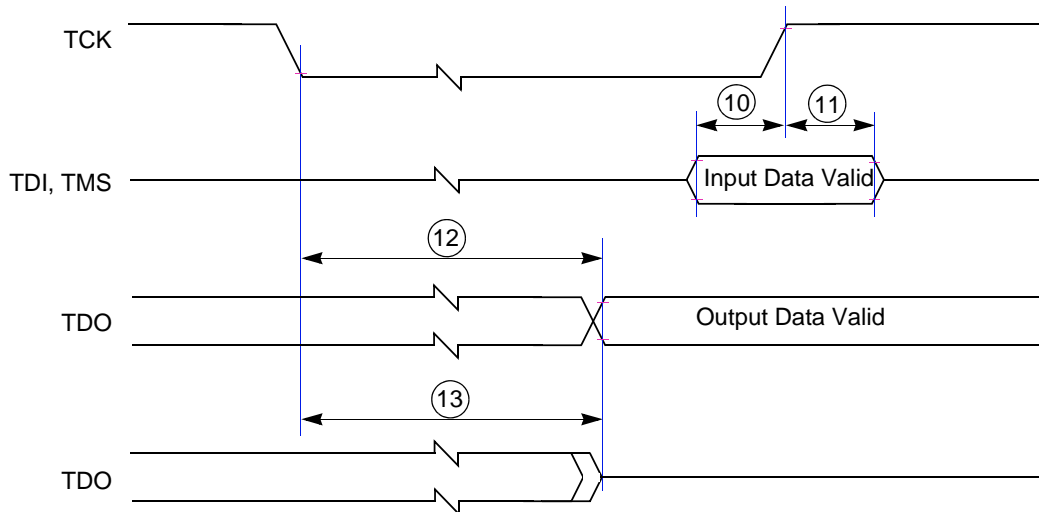

Figure 57. Timing Diagram – Test Access Port

### 3.3.24 VIU

The Video Input Unit (VIU) is an interface which accepts the ITU656 format compatible video stream.

Figure 58 shows the VIU interface timing and Table 52 lists the timing parameters.

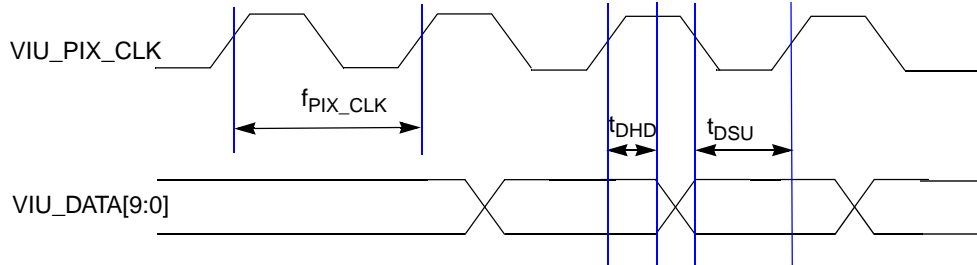

Figure 58. VIU Interface Timing Diagram

Table 52. VIU Interface Timing Parameters

| Parameter     | Description               | Min | Typ | Max | Unit | SpecID |
|---------------|---------------------------|-----|-----|-----|------|--------|
| $f_{PIX\_CK}$ | VIU Pixel Clock Frequency | —   | —   | 83  | MHz  | A24.1  |
| $t_{DSU}$     | VIU Data Setup Time       | 2.5 | —   | —   | ns   | A24.2  |
| $t_{DHD}$     | VIU Data Hold Time        | 2.5 | —   | —   | ns   | A24.3  |

## 4 System Design Information

### 4.1 Power Up/Down Sequencing

Power sequencing between the 1.4 V power supply  $V_{DD\_CORE}$  and the remaining supplies is required to prevent excessive current during power up phase.

The required power sequence is as follows:

- Use 12 V/millisecond or slower time for all supplies.
- Power up  $V_{DD\_IO}$ ,  $PLL\_AV_{DD}$ ,  $V_{BAT\_RTC}$  (if not applied permanently),  $V_{DD\_MEM\_IO}$ , USB PHY, and SATA PHY supplies first in any order and then power up  $V_{DD\_CORE}$ . If required,  $AV_{DD\_FUSEWR}$  should be powered up afterwards.
- All the supplies must reach the specified operating conditions before the  $\overline{PORESET}$  can be released.
- For power down, drop  $AV_{DD\_FUSEWR}$  to 0 V first, drop  $V_{DD\_CORE}$  to 0 V, and then drop all other supplies.
- $V_{DD\_CORE}$  should not exceed  $V_{DD\_IO}$ ,  $V_{DD\_MEM\_IO}$ ,  $V_{BAT\_RTC}$ , or  $PLL\_AV_{DD}$ s by more than 0.4 V at any time, including power-up.

### 4.2 System and CPU Core AVDD Power Supply Filtering

Each of the independent PLL power supplies require filtering external to the device. The following drawing [Figure 59](#) is a recommendation for the required filter circuit.

Each circuit should be placed as close as possible to the specific  $AV_{DD}$  pin being supplied to minimize noise coupled from nearby circuits.

All traces should be as low impedance as possible, especially ground pins to the ground plane.

The filter for System/Core PLL  $V_{DD}$  to  $V_{SS}$  should be connected to the power and ground planes, respectively, not fingers of the planes.

In addition to keeping the filter components for System/Core PLL  $V_{DD}$  as close as practical to the body of the MPC5121e as previously mentioned, special care should be taken to avoid coupling switching power supply noise or digital switching noise onto the portion of that supply between the filter and the MPC5121e.

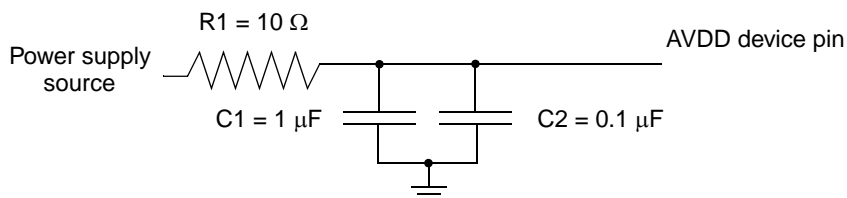

**Figure 59. Power Supply Filtering**

The capacitors for C2 in [Figure 59](#) should be rated X5R or better due to temperature performance. It is recommended to add a bypass capacitance of at least 1 μF for the  $V_{BAT\_RTC}$  pin.

### 4.3 Connection Recommendations

To ensure reliable operation, connect unused inputs to an appropriate signal level. Unused active low inputs should be tied to  $V_{DD\_IO}$ . Unused active high inputs should be connected to  $V_{SS}$ . All NC (no-connect) signals must remain unconnected.

Power and ground connections must be made to all external  $V_{DD}$  and  $V_{SS}$  pins of the MPC5121e/MPC5123.

The unused  $AV_{DD\_FUSEWR}$  power should be connected to  $V_{SS}$  directly or via a resistor.

For DDR or LPDDR modes the unused pins MVT[3:0] for DDR2 Termination voltage can be unconnected.

## System Design Information

The SATA PHY needs to be powered even if it is not used in an application. In this case, you should not enable the SATA oscillator and the SATA PHY by software.

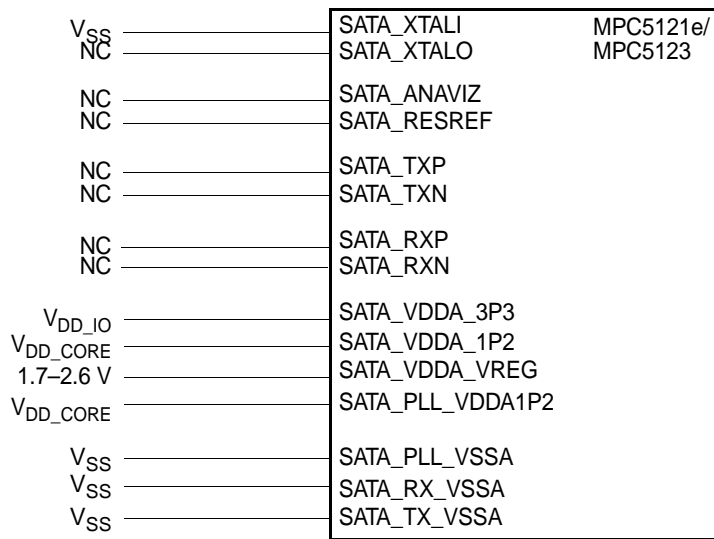

**Figure 60. Recommended Connection for Pins of Unused SATA PHY**

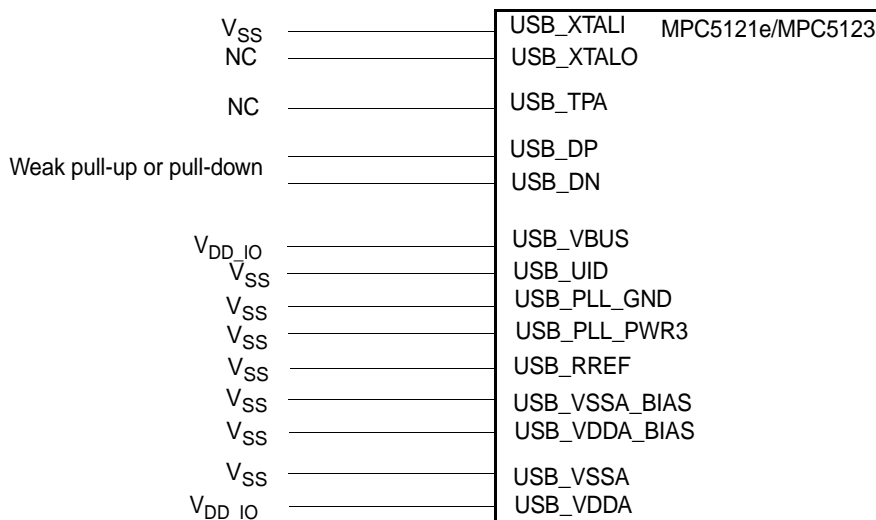

**Figure 61. Recommended connection for pins of unused USB PHY**

## 4.4 Pull-Up/Pull-Down Resistor Requirements

The MPC5121e/MPC5123 requires external pull-up or pull-down resistors on certain pins.

### 4.4.1 Pull-Down Resistor Requirements for TEST pin

The MPC5121e/MPC5123 requires a pull-down resistor on the test pin TEST.



## 4.4.2 Pull-Up Requirements for the PCI Control Lines

PCI control signals always require pull-up resistors on the motherboard (not the expansion board) to ensure that they contain stable values when no agent is actively driving the bus. This includes  $\overline{\text{PCI\_FRAME}}$ ,  $\overline{\text{PCI\_TRDY}}$ ,  $\overline{\text{PCI\_IRDY}}$ ,  $\overline{\text{PCI\_DEVSEL}}$ ,  $\overline{\text{PCI\_STOP}}$ ,  $\overline{\text{PCI\_SERR}}$ ,  $\overline{\text{PCI\_PERR}}$ , and  $\overline{\text{PCI\_REQ}}$ .

Refer to the PCI Local Bus specification.

## 4.5 JTAG

The MPC5121e/MPC5123 provides you with an IEEE 1149.1 JTAG interface to facilitate board/system testing. It also provides a Common On-Chip Processor (COP) Interface, which shares the IEEE 1149.1 JTAG port.

The COP Interface provides access to the MPC5121e/MPC5123's embedded e300 processor and to other on-chip resources. This interface provides a means for executing test routines and for performing software development and debug functions.

### 4.5.1 $\overline{\text{TRST}}$

Boundary scan testing is enabled through the JTAG interface signals. The  $\overline{\text{TRST}}$  signal is optional in the IEEE 1149.1 specification but is provided on all processors that implement the Power Architecture. To obtain a reliable power-on reset performance, the  $\overline{\text{TRST}}$  signal must be asserted during power-on reset.

#### 4.5.1.1 $\overline{\text{TRST}}$ and $\overline{\text{PORESET}}$

The JTAG interface can control the direction of the MPC5121e/MPC5123 I/O pads via the boundary scan chain. The JTAG module must be reset before the MPC5121e/MPC5123 comes out of power-on reset; do this by asserting  $\overline{\text{TRST}}$  before  $\overline{\text{PORESET}}$  is released.

For more details refer to the Reset and JTAG Timing Specification.



Figure 62.  $\overline{\text{PORESET}}$  vs.  $\overline{\text{TRST}}$

## 4.5.2 e300 COP/BDM Interface

There are two possibilities to connect the JTAG interface: using it with a COP connector and without a COP connector.

### 4.5.2.1 Boards Interfacing the JTAG Port via a COP Connector

The MPC5121e/MPC5123 functional pin interface and internal logic provides access to the embedded e300 processor core through the Freescale standard COP/BDM interface. Table 53 gives the COP/BDM interface signals. The pin order shown reflects only the COP/BDM connector order.

**Table 53. COP/BDM Interface Signals**

| BDM Pin # | MPC5121e/MPC5123 I/O Pin       | BDM Connector       | Internal Pull Up/Down | External Pull Up/Down | I/O <sup>1</sup> |
|-----------|--------------------------------|---------------------|-----------------------|-----------------------|------------------|
| 16        | —                              | GND                 | —                     | —                     | —                |
| 15        | $\overline{\text{CKSTP\_OUT}}$ | ckstp_out           | —                     | 10 k $\Omega$ Pull-up | I                |
| 14        | —                              | KEY                 | —                     | —                     | —                |
| 13        | $\overline{\text{HRESET}}$     | hreset              | Pull-up               | 10 k $\Omega$ Pull-up | O                |
| 12        | —                              | GND                 | —                     | —                     | —                |
| 11        | $\overline{\text{SRESET}}$     | sreset              | Pull-up               | 10 k $\Omega$ Pull-up | O                |
| 10        | —                              | N/C                 | —                     | —                     | —                |
| 9         | TMS                            | tms                 | Pull-up               | 10 k $\Omega$ Pull-up | O                |
| 8         | $\overline{\text{CKSTP\_IN}}$  | ckstp_in            | —                     | 10 k $\Omega$ Pull-up | O                |
| 7         | TCK                            | tck                 | Pull-up               | 10 k $\Omega$ Pull-up | O                |
| 6         | —                              | VDD <sup>2</sup>    | —                     | —                     | —                |
| 5         | See Note <sup>3</sup>          | halted <sup>3</sup> | —                     | —                     | I                |
| 4         | $\overline{\text{TRST}}$       | trst                | Pull-up               | 10 k $\Omega$ Pull-up | O                |
| 3         | TDI                            | tdi                 | Pull-up               | 10 k $\Omega$ Pull-up | O                |
| 2         | See Note <sup>4</sup>          | qack <sup>4</sup>   | —                     | —                     | O                |
| 1         | TDO                            | tdo                 | —                     | —                     | I                |

<sup>1</sup> With respect to the emulator tool's perspective:

Input is really an output from the embedded e300 core.  
Output is really an input to the core.

<sup>2</sup> From the board under test, power sense for chip power.

<sup>3</sup> HALTED is not available from e300 core.

<sup>4</sup> Input to the e300 core to enable/disable soft-stop condition during breakpoints. MPC5121e/MPC5123 internally ties CORE\_QACK to GND in its normal/functional mode (always asserted).

For a board with a COP (common on-chip processor) connector that accesses the JTAG interface and needs to reset the JTAG module, only wiring  $\overline{\text{TRST}}$  and  $\overline{\text{PORESET}}$  is not recommended.

To reset the MPC5121e/MPC5123 via the COP connector, the  $\overline{\text{HRESET}}$  pin of the COP should be connected to the  $\overline{\text{HRESET}}$  pin of the MPC5121e/MPC5123. The circuitry shown in [Figure 63](#) allows the COP to assert  $\overline{\text{HRESET}}$  or  $\overline{\text{TRST}}$  separately, while any other board sources can drive  $\overline{\text{PORESET}}$ .

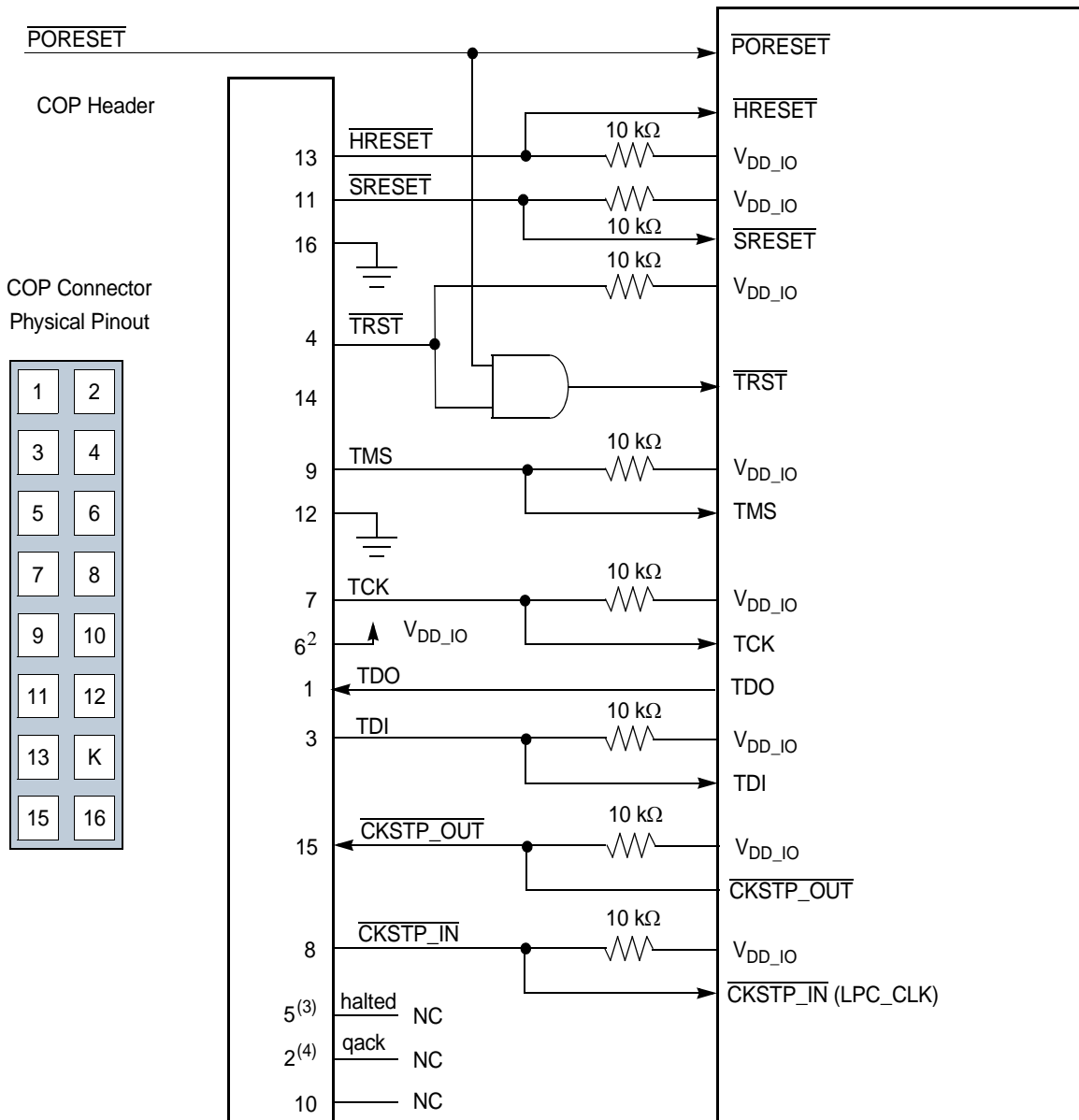

Figure 63. COP Connector Diagram

### 4.5.2.2 Boards Without COP Connector

If the JTAG interface is not used,  $\overline{\text{TRST}}$  should be tied to  $\overline{\text{PORESET}}$ , so that it is asserted when the system reset signal ( $\overline{\text{PORESET}}$ ) is asserted. This ensures that the JTAG scan chain is initialized during power on. Figure 64 shows the connection of the JTAG interface without COP connector.

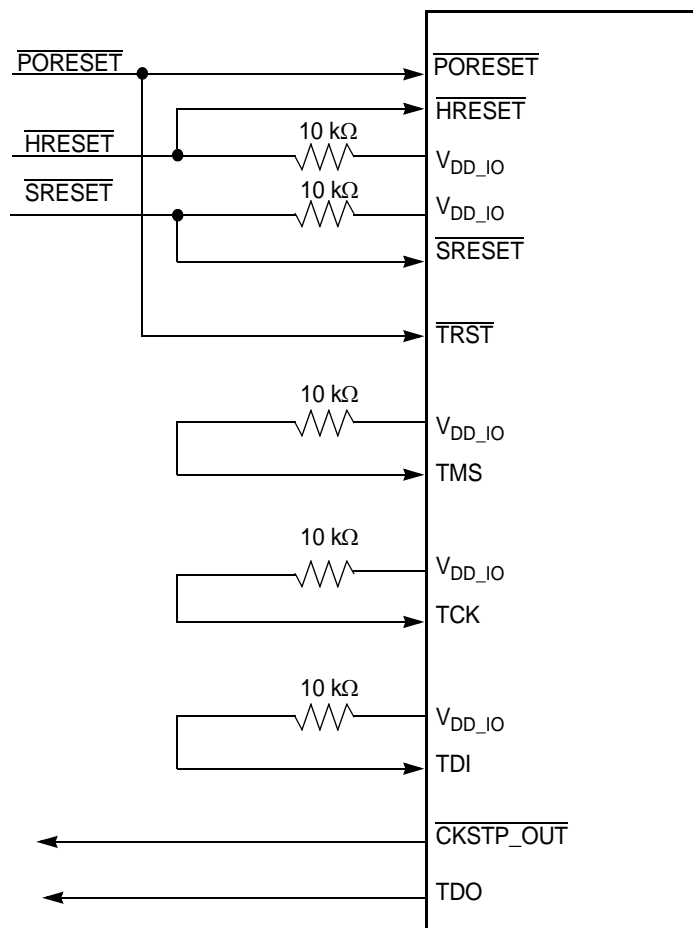

Figure 64.  $\overline{\text{TRST}}$  Wiring for Boards without COP Connector

## 5 Package Information

This section details package parameters and dimensions. The MPC5121e/MPC5123 is available in a Thermally Enhanced Plastic Ball Grid Array (TEPBGA), see [Section 5.1, “Package Parameters,”](#) and [Section 5.2, “Mechanical Dimensions,”](#) for information on the TEPBGA.

### 5.1 Package Parameters

**Table 54. TEPBGA Parameters**

|                         |                            |
|-------------------------|----------------------------|
| Package outline         | 27 mm × 27 mm              |
| Interconnects           | 516                        |
| Pitch                   | 1.00 mm                    |
| Module height (typical) | 2.25 mm                    |
| Solder Balls            | 96.5 Sn/3.5Ag (VY package) |
| Ball diameter (typical) | 0.6 mm                     |

### 5.2 Mechanical Dimensions

[Figure 65](#) shows the mechanical dimensions and bottom surface nomenclature of the MPC5121e/MPC5123 516 PBGA package.

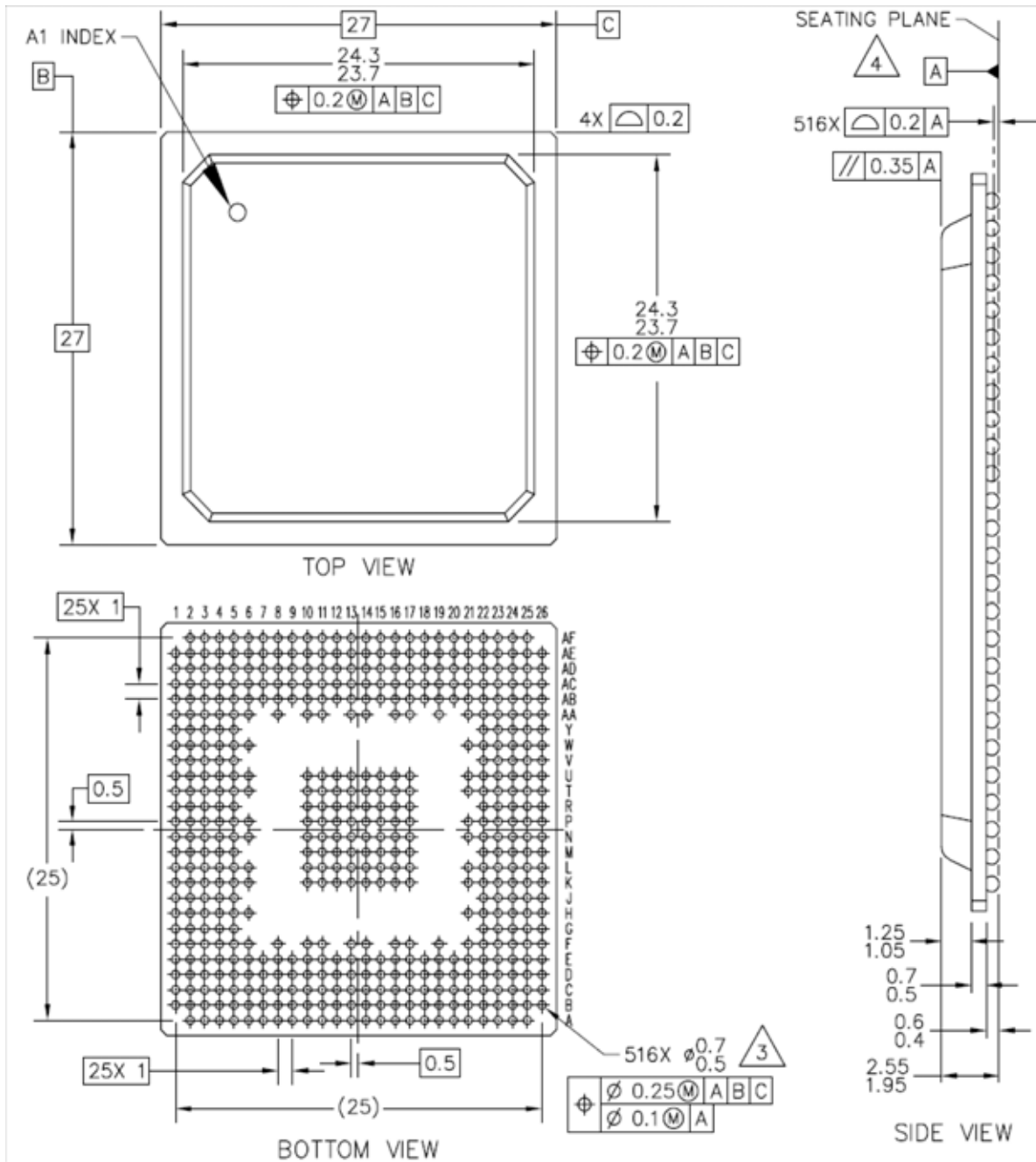

**Figure 65. Mechanical Dimension and Bottom Surface Nomenclature of the MPC5121e/MPC5123 TEPBGA**

- 1 All dimensions are in millimeters.
- 2 Dimensions and tolerances per ASME Y14.5M-1994.
- 3 Maximum solder ball diameter measured parallel to datum A.
- 4 Datum A, the seating plane, is determined by the spherical crowns of the solder balls.

## 6 Product Documentation

This Data Sheet is labeled as a particular type: Product Preview, Advance Information, or Technical Data. Definitions of these types are available at: <http://www.freescale.com>.

Table 55 provides a revision history for this document.

**Table 55. Document Revision History**

| Revision       | Substantive Change(s)   |
|----------------|---|
| Rev. 0, DraftA | First Draft (5/2008)  |
| Rev. 0, DraftB | Second Draft (5/2008)   |
| Rev. 0, DraftC | Third Draft (7/2008)  |
| Rev. 1         | Advance Information (10/2008)   |
| Rev. 2         | Technical Data (2/2009)   |
| Rev. 3         | Technical Data (2/2009). Corrected Table 5, Footnote 3.   |
| Rev. 3.1       | Technical Data (12/2009). Interim release for removing AVDD_FUSERD throughout document, changing pin D9 to VDD_IO, and adding D9 to list of pins for VDD_IO.  |
| Rev. 4         | Technical Data (1/2010). Minor editorial and graphical updates.<br>No technical updates.  |
| Rev 5          | <ul style="list-style-type: none"> <li>— Updated table “DDR and DDR2 SDRAM Timing Specification”, removed the row of ‘MCK AC differential crosspoint voltage’.</li> <li>— Updated table “Thermal Resistance Data”.</li> <li>— Added table “NFC Timing Characteristics in Symmetric Mode ”and added figure “Read data latch timing in Symmetric Mode”.</li> <li>— Published as Rev. 5</li> </ul> |

## **How to Reach Us:**

### **Home Page:**

[www.freescale.com](http://www.freescale.com)

### **Web Support:**

<http://www.freescale.com/support>

### **USA/Europe or Locations Not Listed:**

Freescale Semiconductor, Inc.  
Technical Information Center, EL516  
2100 East Elliot Road  
Tempe, Arizona 85284  
+1-800-521-6274 or +1-480-768-2130  
[www.freescale.com/support](http://www.freescale.com/support)

### **Europe, Middle East, and Africa:**

Freescale Halbleiter Deutschland GmbH  
Technical Information Center  
Schatzbogen 7  
81829 Muenchen, Germany  
+44 1296 380 456 (English)  
+46 8 52200080 (English)  
+49 89 92103 559 (German)  
+33 1 69 35 48 48 (French)  
[www.freescale.com/support](http://www.freescale.com/support)

### **Japan:**

Freescale Semiconductor Japan Ltd.  
Headquarters  
ARCO Tower 15F  
1-8-1, Shimo-Meguro, Meguro-ku,  
Tokyo 153-0064  
Japan  
0120 191014 or +81 3 5437 9125  
[support.japan@freescale.com](mailto:support.japan@freescale.com)

### **Asia/Pacific:**

Freescale Semiconductor China Ltd.  
Exchange Building 23F  
No. 118 Jianguo Road  
Chaoyang District  
Beijing 100022  
China  
+86 10 5879 8000  
[support.asia@freescale.com](mailto:support.asia@freescale.com)

### **For Literature Requests Only:**

Freescale Semiconductor Literature Distribution Center  
P.O. Box 5405  
Denver, Colorado 80217  
1-800-441-2447 or 303-675-2140

Document Number: MPC5121E  
Rev. 5  
02/2012

Information in this document is provided solely to enable system and software implementers to use Freescale Semiconductor products. There are no express or implied copyright licenses granted hereunder to design or fabricate any integrated circuits or integrated circuits based on the information in this document.

Freescale Semiconductor reserves the right to make changes without further notice to any products herein. Freescale Semiconductor makes no warranty, representation or guarantee regarding the suitability of its products for any particular purpose, nor does Freescale Semiconductor assume any liability arising out of the application or use of any product or circuit, and specifically disclaims any and all liability, including without limitation consequential or incidental damages. "Typical" parameters that may be provided in Freescale Semiconductor data sheets and/or specifications can and do vary in different applications and actual performance may vary over time. All operating parameters, including "Typicals", must be validated for each customer application by customer's technical experts. Freescale Semiconductor does not convey any license under its patent rights nor the rights of others. Freescale Semiconductor products are not designed, intended, or authorized for use as components in systems intended for surgical implant into the body, or other applications intended to support or sustain life, or for any other application in which the failure of the Freescale Semiconductor product could create a situation where personal injury or death may occur. Should Buyer purchase or use Freescale Semiconductor products for any such unintended or unauthorized application, Buyer shall indemnify and hold Freescale Semiconductor and its officers, employees, subsidiaries, affiliates, and distributors harmless against all claims, costs, damages, and expenses, and reasonable attorney fees arising out of, directly or indirectly, any claim of personal injury or death associated with such unintended or unauthorized use, even if such claim alleges that Freescale Semiconductor was negligent regarding the design or manufacture of the part.

Freescale™ and the Freescale logo are trademarks of Freescale Semiconductor, Inc. All other product or service names are the property of their respective owners.

© Freescale Semiconductor, Inc. 2010-2012. All rights reserved.