

4

3

2

1

THIS DRAWING IS UNPUBLISHED. RELEASED FOR PUBLICATION
 © COPYRIGHT ALL RIGHTS RESERVED.

LOC	DIST	REVISIONS			
P	LTR	DESCRIPTION	DATE	DWN	APVD
	A1	ECR-14-003919	18MAR2014	GK	HMR

REPLACED BY OCEAN STYLE APPLICATOR PART NUMBER 2266162-1

FOR REPLACEMENT PARTS FOR APPLICATOR 1385863
 REFER TO ADDITIONAL PAGE(S). SPARE PARTS KIT (IF LISTED)
 WILL REMAIN AVAILABLE.

THE REPLACEMENT OCEAN STYLE APPLICATOR HAS THE
 SAME TERMINATOR/PRESS INTERFACE AS APPLICATOR
 1385863

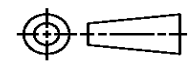
THIS DRAWING IS A CONTROLLED DOCUMENT.		DWN	GOPALAKRISHNA HV		
DIMENSIONS:		CHK	RAGHAVENDRA		
		APVD	RAGHAVENDRA		
TOLERANCES UNLESS OTHERWISE SPECIFIED:		PRODUCT SPEC	NAME		
0 PLC	±	APPLICATION SPEC	SIDE FEED HDM APPLICATOR		
1 PLC	±		SIZE	CAGE CODE	DRAWING NO
2 PLC	±		A3		©- 1385863
3 PLC	±				RESTRICTED TO
4 PLC	±				
ANGLES	±	WEIGHT			
MATERIAL	FINISH	CUSTOMER DRAWING	SCALE	SHEET 1 OF 3	REV A1



THIS DRAWING IS A CONTROLLED DOCUMENT

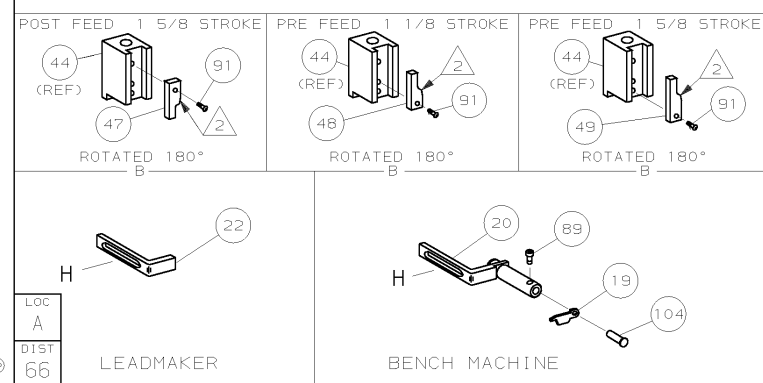
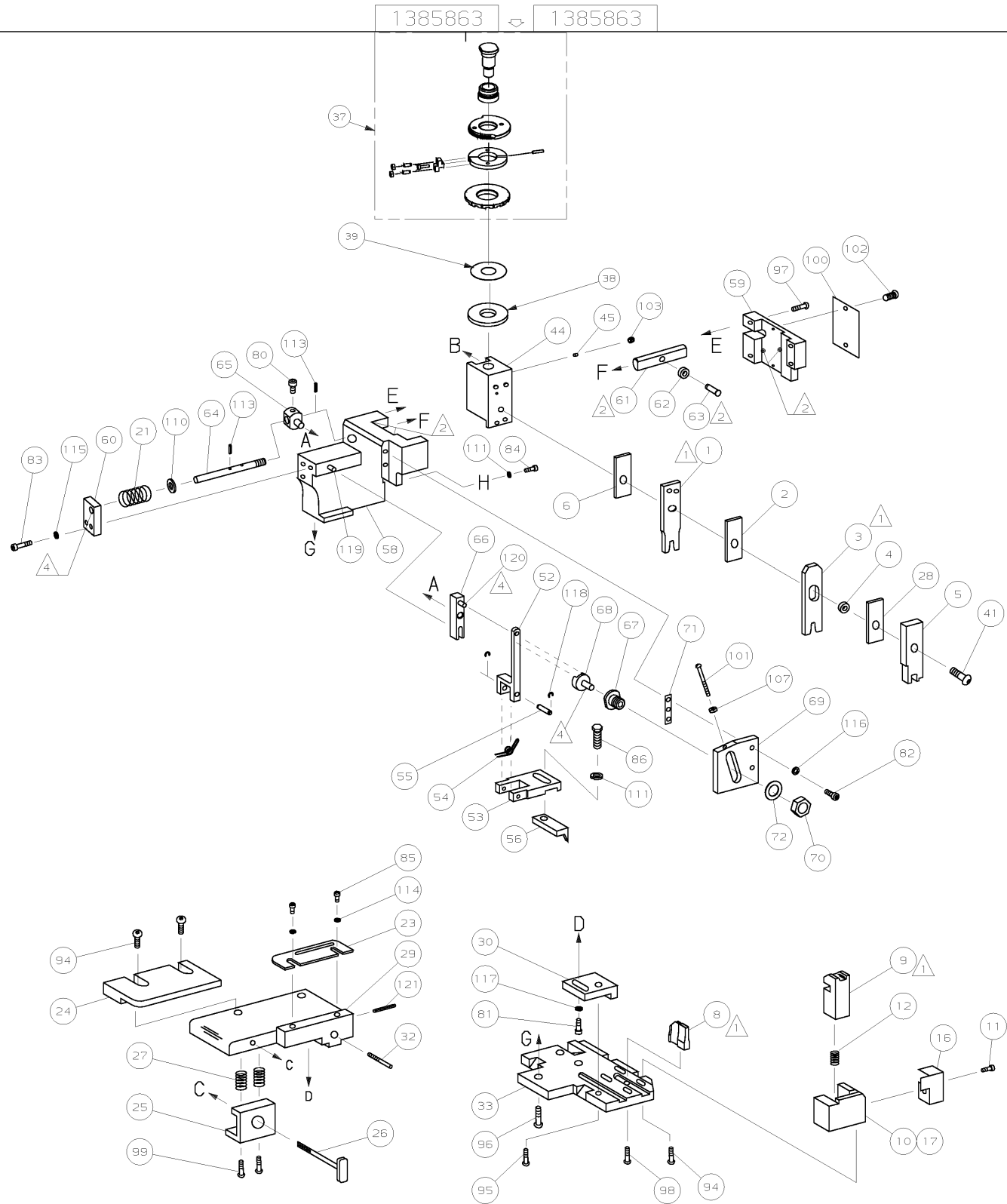

RELEASED FOR PUBLICATION JANUARY 14, 2005
 ALL RIGHTS RESERVED.
 THIS DRAWING IS UNCONTROLLED
 © COPYRIGHT 2005

LOC A	18-JAN-05	06:46:18	us024474
DIST 66			

QTY REQD PER ASSY	DWG SIZE	PART NO	DESCRIPTION	ITEM NO
← REVISION OF EACH ASSY NO (WHEN BLANK, USE DWG REVISION)				
PARTS LIST				
MATL		HT TR		FIN
DR		APP		
CHK		REL		
NAME SIDE FEED HDM APPLICATOR			MACHINE REF	
SCALE		DWG NO	1385863	SHEET 2 of 2 REV A
CASE CODE	00779	CUSTOMER AND ASSEMBLY DRAWING		RESTRICTED TO

SEE SHEET 1
REVISION RECORD
APP DATE