

Spezifikation für Freigabe / specification for release

Kunde / customer :
 Artikelnummer / part number : **749053012**
 Bezeichnung : **LAN-Übertrager WE-LAN 10G**
 description : **LAN-Transformer WE-LAN 10G**



DATUM / DATE : 2015-11-02

A Mechanische Abmessungen / dimensions :

	10G BaseT PoE+
--	-----------------------

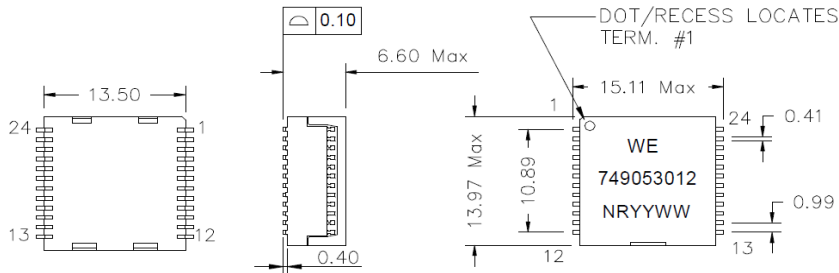

B Elektrische Eigenschaften / electrical properties :

Eigenschaften / properties	Testbedingungen / test conditions		Wert / value	Einheit / unit	tol.
Induktivität / Inductance	100kHz / 100mV @ 8mA DC-Bias	OCL	200	μH	min.
Übersetzungsverhältnis / Turns ratio	100kHz / 100mV	TR	1:1		±2%
Insertion Loss	100KHz-1MHz	IL	-3,0	dB	max.
	1MHz-250MHz		-1,0		
	250MHz-500MHz		-3,0		
Return Loss	1-40MHz	RL	-20,0	dB	min.
	100MHz		-16,0		
	200MHz		-13,0		
	250MHz		-11,2		
	400MHz		-10,0		
Common to Differential Mode Rejection	1MHz-100MHz	CDMR	-35,0	dB	min.
	100MHz-250MHz		-30,0		
	250MHz-500MHz		-25,0		
Common to Common Mode Rejection	1MHz-100MHz	CMRR	-35,0	dB	min.
	100MHz-300MHz		-30,0		
	300MHz-500MHz		-25,0		
Crosstalk	1MHz-500MHz	CT	-30,0	dB	min.

C Lötpad / soldering spec. :

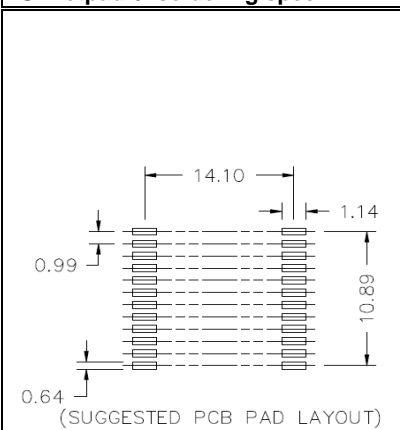

D Prüfgeräte / test equipment :

Agilent E5071C

E Testbedingungen / test conditions :

Luftfeuchtigkeit / Humidity: 33%
 Umgebungstemperatur / Temperature: +25°C

F Werkstoffe & Zulassungen / material & approvals :

Basismaterial / Base material: Ferrit / Ferrite
 Draht / Wire: OUEW 180
 Kontaktmaterial / Contact plating: Cu-Ni-Sn
 Gehäuse / Case: UL94V-0
 Verguss / Potting: UL94V-0

G Eigenschaften / general specifications :

Betriebstemp. / Operating temperature: -40°C - +85°C
 Hochspannungsprüfung / Hipot test: 1500Vrms 1min.
 Feuchteempfindlichkeit: MSL 1 / Humidity class: MSL 1

Freigabe erteilt / general release:	Kunde / customer			
.....			
Datum / date	Unterschrift / signature			
.....	Würth Elektronik			
.....			
Geprüft / checked	Kontrolliert / approved	JaB	Revision 01	2015-11-02
.....	Name	Änderung / modification	Datum / date

Würth Elektronik eiSos GmbH & Co.KG

D-74638 Waldenburg · Max-Eyth-Straße 1 - 3 · Germany · Telefon (+49) (0) 7942 - 945 - 0 · Telefax (+49) (0) 7942 - 945 - 400
<http://www.we-online.com>

Spezifikation für Freigabe / specification for release

Kunde / customer :
 Artikelnummer / part number : **749053012**
 Bezeichnung : **LAN-Übertrager WE-LAN 10G**
 description : **LAN-Transformer WE-LAN 10G**



DATUM / DATE : 2015-11-02

H PoE Eigenschaften :

Designed für Applikationen bis 15W @57VDC
 wenn zwei Kanäle bestromt
 Designed für Applikationen bis 30W @57VDC
 wenn alle vier Kanäle bestromt

H PoE Specifications :

Designed to support applications up to 15W @57VDC
 when using two channels
 Designed to support applications up to 30W @57VDC
 when using four channels

I Schaltbild / Schematics :

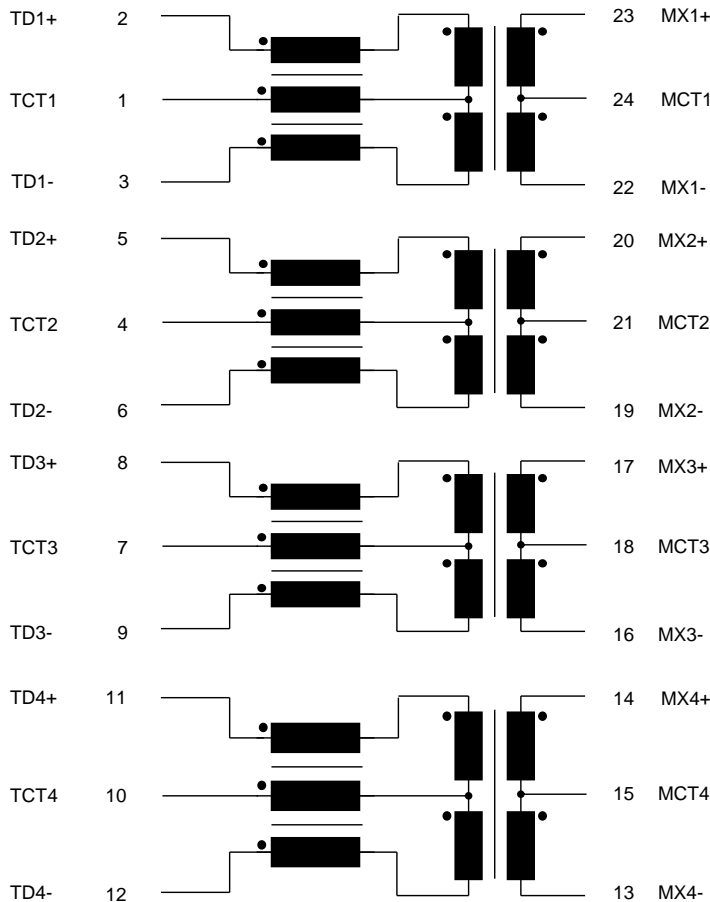

Freigabe erteilt / general release:

Kunde / customer

Datum / date

Unterschrift / signature

Würth Elektronik

Geprüft / checked

Kontrolliert / approved

JaB

Revision 01

2015-11-02

Name

Änderung / modification

Datum / date

This electronic component has been designed and developed for usage in general electronic equipment. Before incorporating this component into any equipment where higher safety and reliability is especially required or if

Würth Elektronik eiSos GmbH & Co.KG

D-74638 Waldenburg · Max-Eyth-Straße 1 - 3 · Germany · Telefon (+49) (0) 7942 - 945 - 0 · Telefax (+49) (0) 7942 - 945 - 400

<http://www.we-online.com>

Spezifikation für Freigabe / specification for release

Kunde / customer :

Artikelnummer / part number :

749053012



Bezeichnung : **LAN-Übertrager WE-LAN 10G**

description : **LAN-Transformer WE-LAN 10G**

DATUM / DATE : 2015-11-02

J Rollenspezifikation / tape and reel specification :

Gurtspezifikation / Tape specification:

PACKAGING(Tape & Reel)

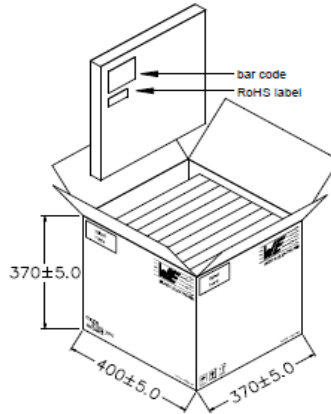
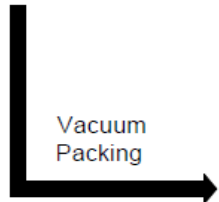
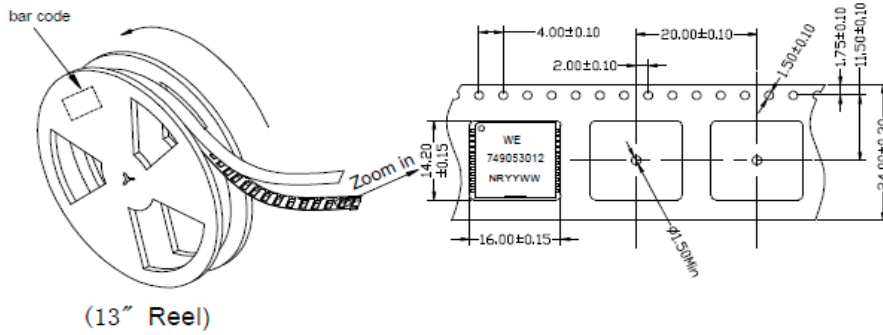

Outside Carton

PACKING QUANTITY:

450pcs Finished Goods / Reel

10 Reel (4500pcs Finished Goods) / Carton

Freigabe erteilt / general release:

Kunde / customer

Datum / date

Unterschrift / signature

Würth Elektronik

Geprüft / checked

Kontrolliert / approved

JaB

Revision 01

2015-11-02

Name

Änderung / modification

Datum / date

This electronic component has been designed and developed for usage in general electronic equipment. Before incorporating this component into any equipment where higher safety and reliability is especially required or if

Würth Elektronik eiSos GmbH & Co.KG

D-74638 Waldenburg · Max-Eyth-Straße 1 - 3 · Germany · Telefon (+49) (0) 7942 - 945 - 0 · Telefax (+49) (0) 7942 - 945 - 400
<http://www.we-online.com>