

LTC2662
5-Channel, 16-/12-Bit, 300mA,
SoftSpan Current Source DACs

DESCRIPTION

Demonstration circuit 2692A-A features the [LTC®2662](#), 5-channel, 16-bit, 300mA, current source DACs with 10ppm/°C reference in a 5mm × 5mm QFN package. This device features per-channel SoftSpan™ configuration of 3.125mA to 300mA, a separate supply for each output, and an internal switch to allow any output pin to be connected to V⁻.

Pin-compatible 12-bit versions are available for lower resolution requirements on the DC2692A-B.

Design files for this circuit board are available at <http://www.analog.com/DC2692A>

All registered trademarks and trademarks are the property of their respective owners.

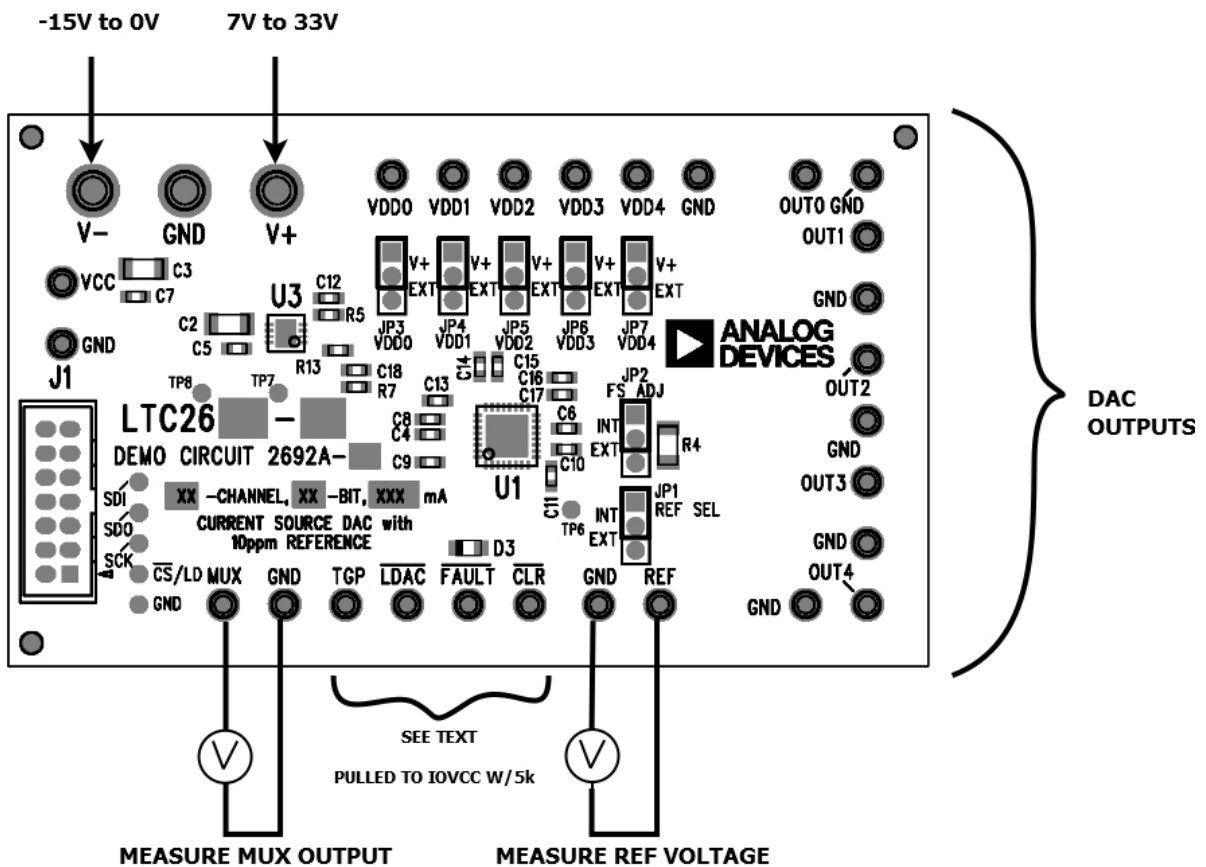

Figure 1. Connection Diagram

ASSEMBLY OPTIONS

ASSEMBLY TYPE	PART NUMBER	DAC CHANNELS	BITS	MAX CURRENT PER CHANNEL
DC2692A-A	LTC2662-16	5	16	300mA
DC2692A-B	LTC2662-12	5	12	300mA

QUICK START PROCEDURE

1. Download and install [QuikEval™](#).
2. Connect a DC590 controller or DC2026 Linduino® with the DC590 emulator firmware to the DC2692A with the supplied ribbon cable.
3. Connect low noise analog power supplies as shown in Figure 1. Refer to the data sheet for other supply options.
4. Connect the controller to the host PC's USB port and run QuikEval. The DC2692A software will be downloaded and installed, after which the GUI will appear as shown in Figure 2. The control panel gives access to all

of the LTC2662's functionality including per-channel SoftSpan ranges, toggling, power-down, etc. Detailed instructions are provided in the Help menu.

Using External Reference for the DC2692

To use an external reference to drive the DC2692, move the jumper named REF SEL (JP1) from the INT position to the EXT position. Use the REF turret to drive the reference voltage. If this is done after the DC2692 was powered up, then the internal reference will need to be disabled from the control register.

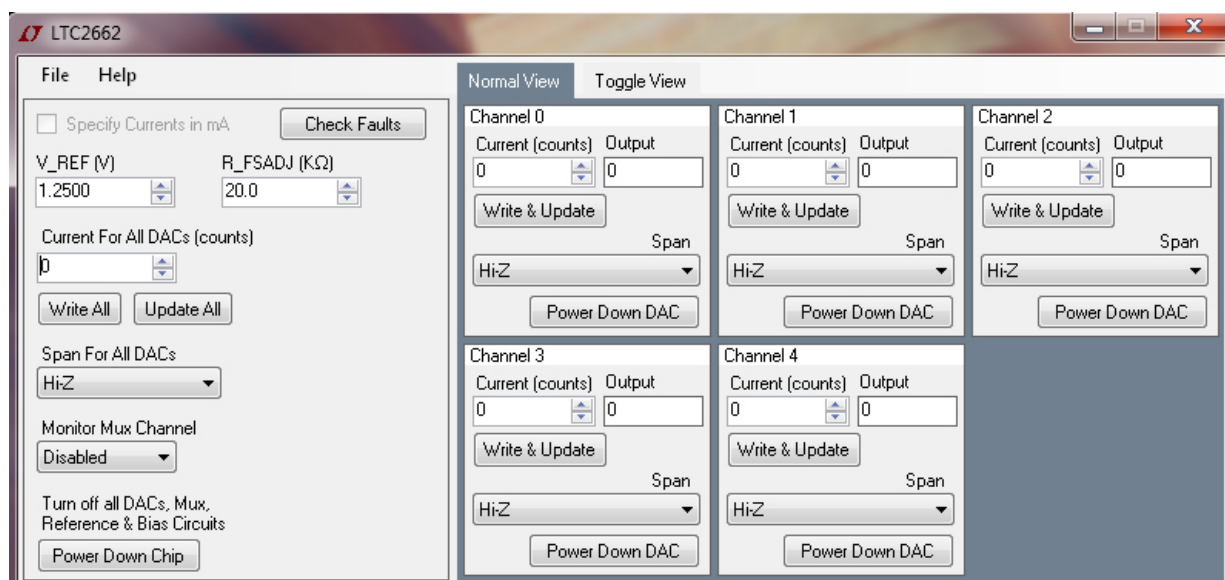

Figure 2. Main Control Panel

QUICK START PROCEDURE

Using External Precision Resistor to Adjust Full-Scale Output Current

The DC2692 has an unstuffed resistor (R4) that can be used to set and adjust the full-scale output current. Move the jumper named FS ADJ (JP2) from INT to EXT. It is recommended to use a resistor with better than 2ppm/°C temperature coefficient to take advantage of the LTC2662 low temperature coefficient. Values between 19k and 50k can be used for the precision resistor.

Using External Supplies for V_{DDx}

The DC2692 can be configured to connect different supplies than V^+ . Move the jumper labeled V_{DDx} from V^+ to EXT and connect the low noise supply to the corresponding V_{DDx} turret.

Connectors and Turrets

J1: Interface connector to DC590 controller or Linduino provides IOVCC power, SPI interface, and board identification.

V^- , GND, V^+ : Analog supplies, connected to the LTC2662 V^+ and V^- pins. Nominally positive supply should be 7V to 33V and negative supply should be 0V to $-15V$. Refer to the data sheet for other supply configurations.

GND: Additional ground posts and exposed ground plane around the board edge allow solid connection to prototype circuitry and measurement equipment.

V_{CC} : Analog supply voltage. Normally supplied by an onboard LT3042 regulator set to 5V that is powered from the V^+ supply. For single supply applications, V_{CC} may be tied directly to V^+ and supplied with 2.85V to 5.5V.

V_{DD0} to V_{DD4} : Output supply voltage. A jumper is used to connect the output supply to V^+ . Placing the jumper in the EXT position allows the output supply voltage channel to be connected externally to this point.

REF: Connection to the REF pin. In internal reference mode, the reference voltage may be monitored at this point. Placing REF SEL jumper in EXT position allows an external low noise reference to be connected to this point. Refer to the data sheet for compatible voltages.

MUX: Monitor Mux output. Allows surveying the DAC outputs under software control. Must be measured with a high impedance meter (output impedance is nominally 10k Ω).

OUT0 – OUT4: DAC outputs.

\overline{CLR} : Asynchronous clear input (pulled high to IOVCC with a 5k resistor). Pull to the ground to reset the DAC to the power-on reset value.

TGP: Toggle input (pulled high to IOVCC with a 5k resistor). A high level on this pin enables software toggling. See data sheet for a complete description of toggle operation.

\overline{LDAC} : Asynchronous DAC update. If \overline{CS}/LD is high at the falling edge of \overline{LDAC} , DAC outputs will be updated with the contents of the input registers. If \overline{CS}/LD is low when \overline{LDAC} goes low, the DAC registers are updated after \overline{CS}/LD returns high.

\overline{FAULT} : Fault detection pin (pulled high to IOVCC with a 5k resistor). The LTC2662 pulls this pin low if a fault is detected. It is released on the next rising edge of \overline{CS}/LD .

Jumpers

REF SEL (JP1): Selects internal or external reference mode.

FS ADJ (JP2): Sets the full-scale current for the DACs. Ensure FS ADJ is set to EXT position when using an external precision resistor.

V_{DD0} , V_{DD1} , V_{DD2} , V_{DD3} , V_{DD4} (J3, J4, J5, J6, J7): Select the output supply voltages for the DACs to be either V^+ or external via the turret.

LEDs

\overline{FAULT} : Lights when \overline{FAULT} pin asserts, indicating a fault has occurred. (Note that LED will light if positive analog supply is present and IOVCC is not. IOVCC is normally supplied by the controller.)

Test Points

The SPI bus is available on a row of through-hole test points next to J1 that may be used to monitor the bus or drive the bus with an external controller.

EEGND, WP: For factory use only.



ESD Caution

ESD (electrostatic discharge) sensitive device. Charged devices and circuit boards can discharge without detection. Although this product features patented or proprietary protection circuitry, damage may occur on devices subjected to high energy ESD. Therefore, proper ESD precautions should be taken to avoid performance degradation or loss of functionality.

Legal Terms and Conditions

By using the evaluation board discussed herein (together with any tools, components documentation or support materials, the "Evaluation Board"), you are agreeing to be bound by the terms and conditions set forth below ("Agreement") unless you have purchased the Evaluation Board, in which case the Analog Devices Standard Terms and Conditions of Sale shall govern. Do not use the Evaluation Board until you have read and agreed to the Agreement. Your use of the Evaluation Board shall signify your acceptance of the Agreement. This Agreement is made by and between you ("Customer") and Analog Devices, Inc. ("ADI"), with its principal place of business at One Technology Way, Norwood, MA 02062, USA. Subject to the terms and conditions of the Agreement, ADI hereby grants to Customer a free, limited, personal, temporary, non-exclusive, non-sublicensable, non-transferable license to use the Evaluation Board FOR EVALUATION PURPOSES ONLY. Customer understands and agrees that the Evaluation Board is provided for the sole and exclusive purpose referenced above, and agrees not to use the Evaluation Board for any other purpose. Furthermore, the license granted is expressly made subject to the following additional limitations: Customer shall not (i) rent, lease, display, sell, transfer, assign, sublicense, or distribute the Evaluation Board; and (ii) permit any Third Party to access the Evaluation Board. As used herein, the term "Third Party" includes any entity other than ADI, Customer, their employees, affiliates and in-house consultants. The Evaluation Board is NOT sold to Customer; all rights not expressly granted herein, including ownership of the Evaluation Board, are reserved by ADI. CONFIDENTIALITY. This Agreement and the Evaluation Board shall all be considered the confidential and proprietary information of ADI. Customer may not disclose or transfer any portion of the Evaluation Board to any other party for any reason. Upon discontinuation of use of the Evaluation Board or termination of this Agreement, Customer agrees to promptly return the Evaluation Board to ADI. ADDITIONAL RESTRICTIONS. Customer may not disassemble, decompile or reverse engineer chips on the Evaluation Board. Customer shall inform ADI of any occurred damages or any modifications or alterations it makes to the Evaluation Board, including but not limited to soldering or any other activity that affects the material content of the Evaluation Board. Modifications to the Evaluation Board must comply with applicable law, including but not limited to the RoHS Directive. TERMINATION. ADI may terminate this Agreement at any time upon giving written notice to Customer. Customer agrees to return to ADI the Evaluation Board at that time. LIMITATION OF LIABILITY. THE EVALUATION BOARD PROVIDED HEREUNDER IS PROVIDED "AS IS" AND ADI MAKES NO WARRANTIES OR REPRESENTATIONS OF ANY KIND WITH RESPECT TO IT. ADI SPECIFICALLY DISCLAIMS ANY REPRESENTATIONS, ENDORSEMENTS, GUARANTEES, OR WARRANTIES, EXPRESS OR IMPLIED, RELATED TO THE EVALUATION BOARD INCLUDING, BUT NOT LIMITED TO, THE IMPLIED WARRANTY OF MERCHANTABILITY, TITLE, FITNESS FOR A PARTICULAR PURPOSE OR NON-INFRINGEMENT OF INTELLECTUAL PROPERTY RIGHTS. IN NO EVENT WILL ADI AND ITS LICENSORS BE LIABLE FOR ANY INCIDENTAL, SPECIAL, INDIRECT, OR CONSEQUENTIAL DAMAGES RESULTING FROM CUSTOMER'S POSSESSION OR USE OF THE EVALUATION BOARD, INCLUDING BUT NOT LIMITED TO LOST PROFITS, DELAY COSTS, LABOR COSTS OR LOSS OF GOODWILL. ADI'S TOTAL LIABILITY FROM ANY AND ALL CAUSES SHALL BE LIMITED TO THE AMOUNT OF ONE HUNDRED US DOLLARS (\$100.00). EXPORT. Customer agrees that it will not directly or indirectly export the Evaluation Board to another country, and that it will comply with all applicable United States federal laws and regulations relating to exports. GOVERNING LAW. This Agreement shall be governed by and construed in accordance with the substantive laws of the Commonwealth of Massachusetts (excluding conflict of law rules). Any legal action regarding this Agreement will be heard in the state or federal courts having jurisdiction in Suffolk County, Massachusetts, and Customer hereby submits to the personal jurisdiction and venue of such courts. The United Nations Convention on Contracts for the International Sale of Goods shall not apply to this Agreement and is expressly disclaimed.