

ITEM	PART NO.	DESCRIPTION	Q'TY	REV	DATE	DESCRIPTION	APPROVAL	REF.
1	KM38	38X38 FAN GUARD, G.T. P/N: SC38-W1		0	08-DEC-08	ORIGINAL RELEASE	<i>MM</i>	
2								
3								
4								
5								

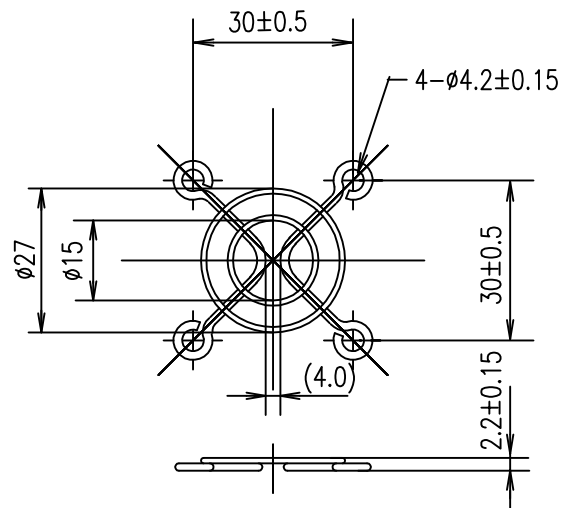

NOTES:

1. MATERIAL: SAE C1008 (OR EQUIVALENT) BRIGHT BASIC WIRE.
2. FINISH: BRIGHT NICKEL CHROME PLATING.
3. WELD JOINTS TO WITHSTAND 88 LBS PULL FORCE.
4. (1) RINGS ARE $\phi 1.0 \pm 0.1$ MM.
(2) RIBS ARE $\phi 1.4 \pm 0.1$ MM.
5. GENERAL TOLERANCE UNLESS NOTED: ± 0.5 MM.

<small>UNLESS NOTED: TOLERANCES SHALL BE X = ±.300 XX = ±.150 XXX = ±.075 ANGULAR = ±.2°</small>	REMARKS		SHOWN Q'TY	OPPOSITE Q'TY
	THIRD ANGLE	SCALE	MATERIAL	APPROVED BY: <i>MM</i>
<small>THIS DRAWING IS THE PROPERTY OF SANYO DENKI AMERICA, INC. AND SHALL BE DEEMED AS PROPRIETARY INFORMATION. USE OF ANY INFORMATION CONTAINED HEREIN SHALL BE PROHIBITED WITHOUT WRITTEN PERMISSION OF SANYO AMERICA, INC.</small>	METRIC		DATE: 08-DEC-08	DATE: 08-DEC-08
	MODEL		NAME 38X38MM FAN FINGER GUARD	
	SANYO DENKI AMERICA, INC. TOLLAND, CALIFORNIA, U.S.A.		DRAWING NO. KM38	REVISED 0