

4

3

2

1

TYCO ELECTRONICS RESERVES THE RIGHT TO AMEND THIS DRAWING AT ANY TIME. USERS SHOULD EVALUATE THE SUITABILITY OF THE PRODUCT FOR THEIR APPLICATION.

REVISIONS			
LTR	DESCRIPTION	DATE	APPROVED
A	INITIAL RELEASE PER DCR# T-32058	OCTOBER/1/03	M.HIGGY
B	REVISED PER DCR# C050472	June/13/05	M.HIGGY

NOTES:

- THIS INSERT IS DESIGNED FOR USE IN TYCO/RAYCHEM CONNECTOR HOUSINGS MTC100-JH2-XXX (SEE TYCO/RAYCHEM INFORMATION DRAWING D-659-0097 AND HOUSING SPECIFICATION CONTROL DRAWINGS FOR FURTHER DETAILS).
- PART DESCRIBED HEREON IS SUPPLIED AS SHOWN. REFER TO TYCO/RAYCHEM INFORMATION DRAWING D-659-0097 FOR CRIMP TOOLS OR ADDITIONAL CONTACTS, SEALING PLUGS OR TOOLS.
- GROMMET DESIGNED TO SEAL ON WIRES HAVING AN INSULATION DIAMETER OF 0.030 TO 0.065.
- PERFORMANCE:
THIS PRODUCT IS DESIGNED TO MEET THE APPLICABLE REQUIREMENTS OF RAYCHEM SPECIFICATION C-6115.
- MATERIALS:

A) PLASTIC INSERT	HIGH GRADE POLYARYLENE THERMOPLASTIC
B) GROMMET	FLUOROSILICONE PER MIL-R-25988
C) INTERFACIAL SEAL	FLUOROSILICONE PER MIL-R-25988
D) RETENTION CLIPS (20)	BERYLLIUM COPPER 172, PER ASTM B194
(INSIDE PLASTIC INSERT)	

6 PART NUMBER, RAYCHEM, B, DATE CODE AND ORIENTATION MARK ARE STAMPED APPROXIMATELY AS SHOWN.

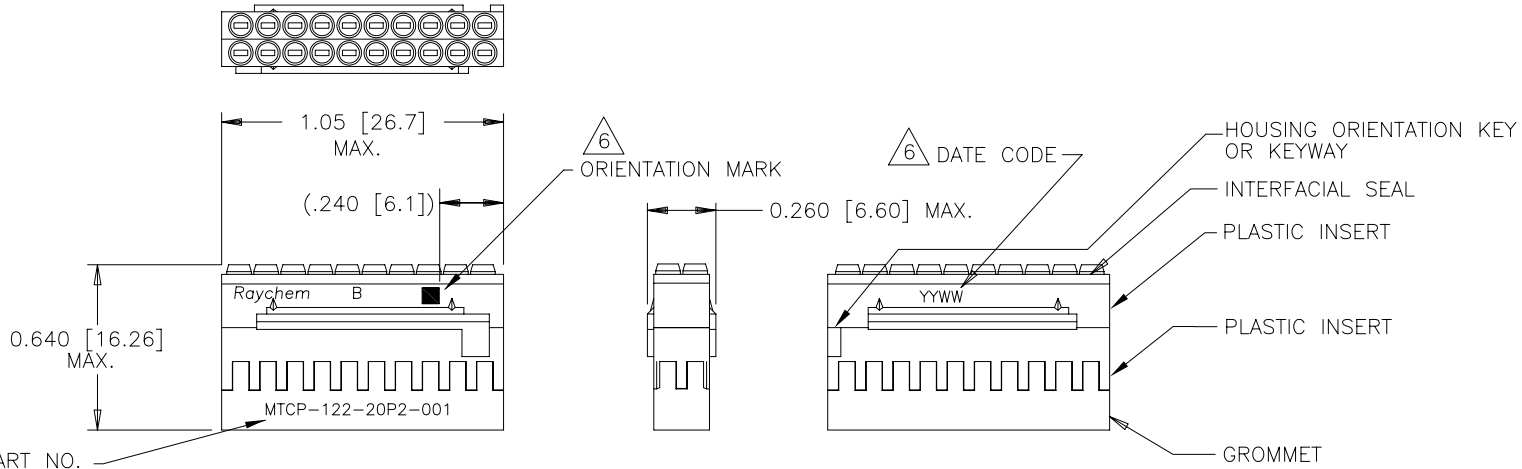
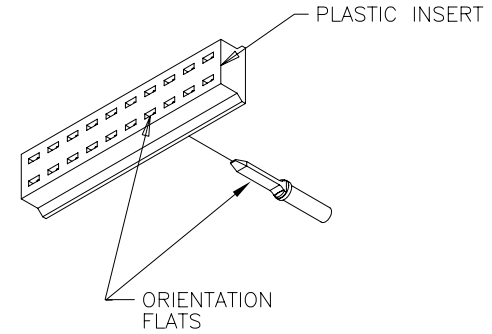

6 PART NO.

SPECIFICATION CONTROL DRAWING

© 2005 Tyco Electronics Corporation. All rights reserved.

UNLESS OTHERWISE SPECIFIED DIMENSIONS ARE IN INCHES. METRIC DIMENSIONS ARE IN BRACKETS.	DRAWN	ZS.ORBAN	September/26/03	tyco Electronics	TYCO ELECTRONICS 300 Constitution Drive Menlo Park, CA. 94025 USA	Raychem	
	CHECKED						
	DECIMALS	.XXX ±			TITLE INSERT, PIN, SECONDARY, 20 CAVITY		
		.XX ±	N/A		SIZE 22-20 REMOVABLE CONTACT, 2 INCH CONNECTOR SPECIAL MARKING-MTC100 SERIES		
ANGLES	.X ±			CAD NAME	C050472.DWG		
WEIGHT	2.06 g MAX.			APPROVED	M.HIGGY	September/26/03	
				THIRD ANGLE PROJECTION			
				SIZE	CAGE CODE:	DWG. NO.	REV
				C	06090	MTCP-122-20P2-001	B
				DO NOT SCALE THIS DRAWING			SHEET 1 OF 1

If this document is printed it becomes uncontrolled. Check for the latest revision.

4

3

2

DWG NO. MTCP-122-20P2-001 SHEET 1