

# **SHARC® Audio EZ-Extender® Manual**

Revision 1.0, September 2009

Part Number  
82-000223-01

Analog Devices, Inc.  
One Technology Way  
Norwood, Mass. 02062-9106



## Copyright Information

© 2009 Analog Devices, Inc., ALL RIGHTS RESERVED. This document may not be reproduced in any form without prior, express written consent from Analog Devices, Inc.

Printed in the USA.

## Disclaimer

Analog Devices, Inc. reserves the right to change this product without prior notice. Information furnished by Analog Devices is believed to be accurate and reliable. However, no responsibility is assumed by Analog Devices for its use; nor for any infringement of patents or other rights of third parties which may result from its use. No license is granted by implication or otherwise under the patent rights of Analog Devices, Inc.

## Trademark and Service Mark Notice

The Analog Devices logo, SHARC, VisualDSP++, EZ-KIT Lite, and EZ-Extender are registered trademarks of Analog Devices, Inc.

EZ-Board is a trademark of Analog Devices, Inc.

All other brand and product names are trademarks or service marks of their respective owners.

## Regulatory Compliance

The SHARC Audio EZ-Extender is designed to be used solely in a laboratory environment. The board is not intended for use as a consumer end product or as a portion of a consumer end product. The board is an open system design, which does not include a shielded enclosure and therefore may cause interference to other electrical devices in close proximity. This board should not be used in or near any medical equipment or RF devices.

The SHARC Audio EZ-Extender is currently being processed for certification that it complies with the essential requirements of the European EMC directive 89/336/EEC amended by 93/68/EEC and therefore carries the “CE” mark.



The EZ-Extender system contains ESD (electrostatic discharge) sensitive devices. Electrostatic charges readily accumulate on the human body and equipment and can discharge without detection. Permanent damage may occur on devices subjected to high-energy discharges. Proper ESD precautions are recommended to avoid performance degradation or loss of functionality. Store unused EZ-Extender boards in the protective shipping package.





# CONTENTS

## PREFACE

|  |      |
|--|------|
| Product Overview .....                 | x    |
| Purpose of This Manual .....           | xi   |
| Intended Audience .....                | xi   |
| Manual Contents .....                  | xii  |
| What's New in This Manual .....        | xii  |
| Technical or Customer Support .....    | xii  |
| Supported Products .....               | xiii |
| Product Information .....              | xiii |
| Analog Devices Web Site .....          | xiv  |
| VisualDSP++ Online Documentation ..... | xiv  |
| Technical Library CD .....             | xv   |
| Related Documents .....                | xvi  |
| Notation Conventions .....             | xvii |

## USING SHARC AUDIO EZ-EXTENDER

|   |     |
|---|-----|
| Package Contents .....                              | 1-2 |
| SHARC Audio EZ-Extender Default Configuration ..... | 1-3 |
| SHARC Audio EZ-Extender Setup .....                 | 1-5 |

# CONTENTS

|                        |     |
|------------------------|-----|
| Audio Interface .....  | 1-5 |
| Example Programs ..... | 1-7 |

## SHARC AUDIO EZ-EXTENDER HARDWARE REFERENCE

|   |      |
|---|------|
| System Architecture .....                     | 2-2  |
| Configuration Switches .....                  | 2-5  |
| Audio Loopback Switches (SW1–6) .....         | 2-6  |
| Audio In1 Left Selection Switch (SW7) .....   | 2-6  |
| Audio In1 Right Selection Switch (SW8) .....  | 2-7  |
| Audio In2 Left Selection Switch (SW9) .....   | 2-8  |
| Audio In2 Right Selection Switch (SW10) ..... | 2-8  |
| Audio In3 Left Selection Switch (SW11) .....  | 2-9  |
| Audio In3 Right Selection Switch (SW12) ..... | 2-10 |
| Audio In4 Left Selection Switch (SW13) .....  | 2-10 |
| Audio In4 Right Selection Switch (SW14) ..... | 2-11 |
| Audio In5 Left Selection Switch (SW15) .....  | 2-12 |
| Audio In5 Right Selection Switch (SW16) ..... | 2-12 |
| Audio In6 Left Selection Switch (SW17) .....  | 2-13 |
| Audio In8 Right Selection Switch (SW18) ..... | 2-14 |
| Memory Configuration Switch (SW19) .....      | 2-14 |
| Soft Reset Enable Switch (SW20) .....         | 2-15 |
| Power LED .....                               | 2-16 |
| Connectors .....                              | 2-17 |
| Expansion Interface II Connector (J1) .....   | 2-18 |
| RCA Audio Connectors (J2–7) .....             | 2-18 |

Differential In/Out Connectors (P1–5) ..... 2-18

**SHARC AUDIO EZ-EXTENDER BILL OF MATERIALS**

**SHARC AUDIO EZ-EXTENDER SCHEMATIC**

Title Page ..... B-1

Expansion Interface, Buffers ..... B-2

AD1939 Codec A (Master) - Audio Page 1 ..... B-3

In1 Via AD1939A ..... B-4

In2 Via AD1939A ..... B-5

Out1 Via AD1939A ..... B-6

Out2 Via AD1939A ..... B-7

Out3 Via AD1939A ..... B-8

Out4 Via AD1939A ..... B-9

AD1939 Codec B ..... B-10

In3 Via AD1939B ..... B-11

In4 Via AD1939B ..... B-12

Out5 Via AD1939B ..... B-13

Out6 Via AD1939B ..... B-14

Out7 Via AD1939B ..... B-15

Out8 Via AD1939B ..... B-16

AD1939 Codec C ..... B-17

In5 Via AD1939C ..... B-18

In6 Via AD1939C ..... B-19

Out9 Via AD1939C ..... B-20

# CONTENTS

|  |      |
|--|------|
| Out10 Via AD1939C .....                | B-21 |
| Out11 Via AD1939C .....                | B-22 |
| Out12 Via AD1939C .....                | B-23 |
| Differential Audio - DB25 In/Out ..... | B-24 |

# INDEX



# PREFACE

Thank you for purchasing the SHARC<sup>®</sup> Audio EZ-Extender<sup>®</sup>, Analog Devices, Inc. daughter board to the EZ-Board<sup>™</sup> evaluation system for the ADSP-21xxx processors.

SHARC processors are based on a 32-bit super Harvard architecture that includes a unique memory architecture comprised of two large on-chip, dual-ported SRAM blocks coupled with a sophisticated IO processor, which gives a SHARC processor the bandwidth for sustained high-speed computations. SHARC processors represents today's de facto standard for floating-point processing, targeted toward premium audio applications.

The EZ-Board and SHARC Audio EZ-Extender are designed to be used in conjunction with the VisualDSP++<sup>®</sup> development environment. VisualDSP++ offers a powerful programming tool with new flexibility that significantly decreases the time required to port software code to a processor, reducing time-to-market.

To learn more about Analog Devices development software, go to <http://www.analog.com/processors/tools/>.

# Product Overview

The SHARC Audio EZ-Extender is a separately sold daughter board that plugs onto the expansion interface II of the ADSP-21469 EZ-Board and all future SHARC evaluation boards. The daughter board aids the design and prototyping phases of analog audio applications.

The board extends the capabilities of the evaluation system by providing a connection to three analog audio codecs.

The SHARC Audio EZ-Extender features:

- Analog audio interface
  - ✓ AD1939 – three Analog Devices 192 kHz audio codecs
  - ✓ 24 channels of audio out (twelve stereo channels)
  - ✓ Twelve channels of audio in (six stereo channels)
  - ✓ TDM and I<sup>2</sup>S modes at 48 KHz, 96 KHz, and 192 KHz sample rates
- Single-ended input/output
  - ✓ Three RCA phono jack inputs (4 x 1)
  - ✓ Three RCA phono jack outputs (4 x 2)
- Differential input/output
  - ✓ Two DB25 connector inputs
  - ✓ Three DB25 connector outputs

All of the power necessary to operate the extender is derived from the mating EZ-Board. Before using any of the interfaces, follow the setup procedure in [“SHARC Audio EZ-Extender Setup”](#) on page 1-5.

Example programs are available to demonstrate capabilities of the SHARC Audio EZ-Extender board.

## Purpose of This Manual

The *SHARC Audio EZ-Extender Manual* describes operation and configuration of the extender board components. A schematic and a bill of materials are provided as a reference guide for future SHARC processor board designs.

## Intended Audience

The primary audience for this manual is a programmer who is familiar with Analog Devices processors. This manual assumes that the audience has a working knowledge of the appropriate processor architecture and instruction set. Programmers who are unfamiliar with Analog Devices processors can use this manual, but should supplement it with other texts (such as the *ADSP-2146x SHARC Processor Hardware Reference for ADSP-21467/8/9 Processors* and *SHARC Processor Instruction Set Reference*) that describe your target architecture.

Programmers who are unfamiliar with VisualDSP++ should refer to the VisualDSP++ online Help and user's or getting started guides. For the locations of these documents, see [“Related Documents”](#).

# Manual Contents

The manual consists of:

- Chapter 1, “[Using SHARC Audio EZ-Extender](#)” on page 1-1  
Provides basic board information.
- Chapter 2, “[SHARC Audio EZ-Extender Hardware Reference](#)” on page 2-1  
Provides information about the hardware aspects of the board.
- Appendix A, “[SHARC Audio EZ-Extender Bill Of Materials](#)” on page A-1  
Provides a list of components used to manufacture the board.
- Appendix B, “[SHARC Audio EZ-Extender Schematic](#)” on page B-1  
Provides the resources to allow board-level debugging or to use as a reference guide. Appendix B is part of the online Help.

## What’s New in This Manual

This is the first revision of the *SHARC Audio EZ-Extender Manual*.

## Technical or Customer Support

You can reach Analog Devices, Inc. Customer Support in the following ways:

- Visit the Embedded Processing and DSP products Web site at [http://www.analog.com/processors/technical\\_support](http://www.analog.com/processors/technical_support)
- E-mail tools questions to [processor.tools.support@analog.com](mailto:processor.tools.support@analog.com)

- E-mail processor questions to  
[processor.support@analog.com](mailto:processor.support@analog.com) (World wide support)  
[processor.europe@analog.com](mailto:processor.europe@analog.com) (Europe support)  
[processor.china@analog.com](mailto:processor.china@analog.com) (China support)
- Phone questions to **1-800-ANALOGD**
- Contact your Analog Devices, Inc. local sales office or authorized distributor
- Send questions by mail to:  
Analog Devices, Inc.  
One Technology Way  
P.O. Box 9106  
Norwood, MA 02062-9106  
USA

## Supported Products

The SHARC Audio EZ-Extender is designed as an extender board to the ADSP-21469 EZ-Board evaluation systems. Future SHARC evaluation systems will be compatible with the SHARC Audio EZ-Extender.

## Product Information

Product information can be obtained from the Analog Devices Web site, VisualDSP++ online Help system, and a technical library CD.

### Analog Devices Web Site

The Analog Devices Web site, [www.analog.com](http://www.analog.com), provides information about a broad range of products—*analog integrated circuits, amplifiers, converters, and digital signal processors.*

To access a complete technical library for each processor family, go to [http://www.analog.com/processors/technical\\_library](http://www.analog.com/processors/technical_library). The manuals selection opens a list of current manuals related to the product as well as a link to the previous revisions of the manuals. When locating your manual title, note a possible errata check mark next to the title that leads to the current correction report against the manual.

Also note, [MyAnalog.com](http://MyAnalog.com) is a free feature of the Analog Devices Web site that allows customization of a Web page to display only the latest information about products you are interested in. You can choose to receive weekly e-mail notifications containing updates to the Web pages that meet your interests, including documentation errata against all manuals. [MyAnalog.com](http://MyAnalog.com) provides access to books, application notes, data sheets, code examples, and more.

Visit [MyAnalog.com](http://MyAnalog.com) to sign up. If you are a registered user, just log on. Your user name is your e-mail address.

### VisualDSP++ Online Documentation

Online documentation comprises the VisualDSP++ Help system, software tools manuals, hardware tools manuals, processor manuals, Dinkum Abridged C++ library, and FLEXnet License Tools software documentation. You can search easily across the entire VisualDSP++ documentation set for any topic of interest.

For easy printing, supplementary Portable Documentation Format (.pdf) files for all manuals are provided on the VisualDSP++ installation CD.

Each documentation file type is described as follows.

| File             | Description   |
|------------------|---|
| .chm             | Help system files and manuals in Microsoft help format  |
| .htm or<br>.html | Dinkum Abridged C++ library and FLEXnet License Tools software documentation. Viewing and printing the .html files requires a browser, such as Internet Explorer 6.0 (or higher). |
| .pdf             | VisualDSP++ and processor manuals in PDF format. Viewing and printing the .pdf files requires a PDF reader, such as Adobe Acrobat Reader (4.0 or higher).                         |

## Technical Library CD

The technical library CD contains seminar materials, product highlights, a selection guide, and documentation files of processor manuals, VisualDSP++ software manuals, and hardware tools manuals for the following processor families: Blackfin, SHARC, TigerSHARC, ADSP-218x, and ADSP-219x.

To order the technical library CD, go to [http://www.analog.com/processors/technical\\_library](http://www.analog.com/processors/technical_library), navigate to the manuals page for your processor, click the request CD check mark, and fill out the order form.

Data sheets, which can be downloaded from the Analog Devices Web site, change rapidly, and therefore are not included on the technical library CD. Technical manuals change periodically. Check the Web site for the latest manual revisions and associated documentation errata.

# Related Documents

For information on product related development software, see the following publications.

Table 1. Related Processor Publications

| Title  | Description  |
|--|--|
| <i>ADSP-21462/ADSP-21465/ADSP-21467/ADSP-21469 SHARC Processor Data Sheet</i>      | General functional description, pinout, and timing of the processor.           |
| <i>ADSP-2146x SHARC Processor Hardware Reference for ADSP-21467/8/9 Processors</i> | Description of the internal processor architecture and all register functions. |
| <i>SHARC Processor Programming Reference</i>                                       | Description of all allowed processor assembly instructions.                    |



Table 2. Related VisualDSP++ Publications

| Title   | Description   |
|---|---|
| <i>ADSP-21469 EZ-Board Evaluation System Manual</i>                       | Description of the hardware capabilities of the evaluation system.      |
| <i>VisualDSP++ User's Guide</i>   | Description of the VisualDSP++ features and usage.                      |
| <i>VisualDSP++ Assembler and Preprocessor Manual</i>                      | Description of the assembler function and commands.                     |
| <i>VisualDSP++ C/C++ Compiler and Library Manual for SHARC Processors</i> | Description of the compiler function and commands for SHARC processors. |
| <i>VisualDSP++ Linker and Utilities Manual</i>                            | Description of the linker function and commands.                        |
| <i>VisualDSP++ Loader and Utilities Manual</i>                            | Description of the loader/splitter function and commands.               |



## Notation Conventions

Text conventions used in this manual are identified and described as follows. Additional conventions, which apply only to specific chapters, may appear throughout this document.

| Example   | Description  |
|---|--|
| {this   that}   | Alternative required items in syntax descriptions appear within curly brackets and separated by vertical bars; read the example as <i>this</i> or <i>that</i> . One or the other is required.  |
| [this   that]   | Optional items in syntax descriptions appear within brackets and separated by vertical bars; read the example as an optional <i>this</i> or <i>that</i> .  |
| [this,...]  | Optional item lists in syntax descriptions appear within brackets delimited by commas and terminated with an ellipsis; read the example as an optional comma-separated list of <i>this</i> .   |
| .SECTION  | Commands, directives, keywords, and feature names are in text with letter gothic font.   |
| <i>filename</i>   | Non-keyword placeholders appear in text with italic style format.  |
|   | <b>Note:</b> For correct operation, ...<br>A Note provides supplementary information on a related topic. In the online version of this book, the word <b>Note</b> appears instead of this symbol.  |
|  | <b>Caution:</b> Incorrect device operation may result if ...<br><b>Caution:</b> Device damage may result if ...<br>A Caution identifies conditions or inappropriate usage of the product that could lead to undesirable results or product damage. In the online version of this book, the word <b>Caution</b> appears instead of this symbol. |
|  | <b>Warning:</b> Injury to device users may result if ...<br>A Warning identifies conditions or inappropriate usage of the product that could lead to conditions that are potentially hazardous for the devices users. In the online version of this book, the word <b>Warning</b> appears instead of this symbol.                              |

## Notation Conventions

# 1 USING SHARC AUDIO EZ-EXTENDER

This chapter describes the SHARC Audio EZ-Extender package contents, configuration, installation procedure, and analog audio interface.

The information is presented in the following order.

- [“Package Contents” on page 1-2](#)  
Describes the product’s package contents.
- [“SHARC Audio EZ-Extender Default Configuration” on page 1-3](#)  
Describes the board’s default configuration.
- [“SHARC Audio EZ-Extender Setup” on page 1-5](#)  
Provides the board’s setup procedure.
- [“Audio Interface” on page 1-5](#)  
Describes the board’s analog audio interface.
- [“Example Programs” on page 1-7](#)  
Describes the example programs installed with the board’s software.

For more information about the mating ADSP-21469 processor, see documents referred to as [“Related Documents”](#).

# Package Contents

Your SHARC Audio EZ-Extender package contains the following items.

- SHARC Audio EZ-Extender board
- *VisualDSP++ Installation Quick Reference Card*
- CD containing:
  - ✓ VisualDSP++ software
  - ✓ SHARC Audio EZ-Extender debug software
  - ✓ Example programs
  - ✓ SHARC Audio EZ-Extender *Manual* (this document)
- 3.5 mm stereo headphones
- 6-foot RCA audio cable
- 6-foot 3.5 mm/RCA x 2 Y-cable
- 3.5 mm stereo female to RCA male Y-cable

If any item is missing, contact the vendor where you purchased your EZ-Extender or contact Analog Devices, Inc.

# SHARC Audio EZ-Extender Default Configuration

The EZ-Extender system contains ESD (electrostatic discharge) sensitive devices. Electrostatic charges readily accumulate on the human body and equipment and can discharge without detection. Permanent damage may occur on devices subjected to high-energy discharges. Proper ESD precautions are recommended to avoid performance degradation or loss of functionality. Store unused EZ-Extender boards in the protective shipping package.



The SHARC Audio EZ-Extender board is designed to run outside your personal computer as a stand-alone unit. You do not have to open your computer case.

When removing the extender board from the package, handle the board carefully to avoid the discharge of static electricity, which may damage some components. [Figure 1-1](#) shows the default jumper and switch settings, connector locations, and LED used in installation. Confirm that your board is in the default configuration before using the board.

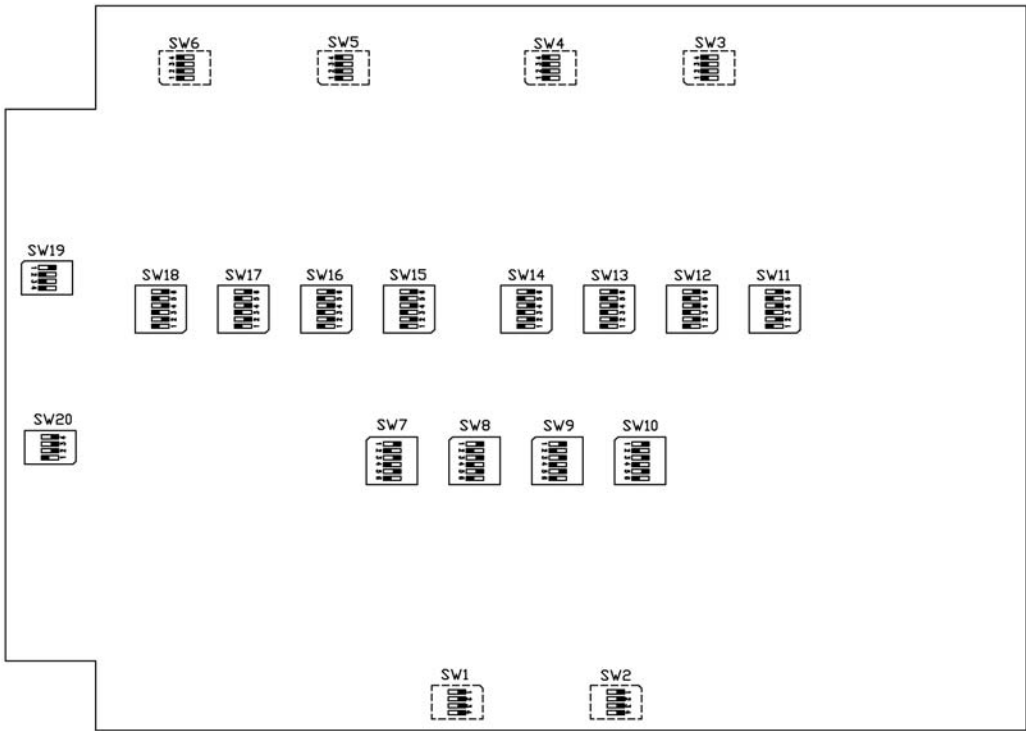

Figure 1-1. EZ-Extender Lite Hardware Setup

# SHARC Audio EZ-Extender Setup

It is important to set up all components of the system containing the SHARC Audio EZ-Extender, then apply power to the system. The following procedure is recommended for the correct setup.

Power your system after these steps are completed:

1. Read the audio interface section in this chapter—the text provides an overview of the interface capabilities.
2. Read [“System Architecture” on page 2-2](#) to understand physical connections of the daughter board. For detailed information, refer to [“SHARC Audio EZ-Extender Schematic” on page B-1](#).
3. Refer to the readme text files in the `<install_path>\214xx\Examples\SHARC Audio EZ-Extender` directories of VisualDSP++ 5.0 update 7 (or later) for information on how to configure the SHARC Audio EZ-Extender board and mating EZ-Board. For custom setups, use [“System Architecture” on page 2-2](#) in conjunction with [“SHARC Audio EZ-Extender Hardware Reference” on page 2-1](#).

## Audio Interface

The SHARC Audio EZ-Extender’s analog audio interface is comprised of three Analog Devices AD1939 multichannel audio codecs.

The AD1939 is a high performance, single-chip codec featuring four analog-to-digital converters (ADCs) for audio input and eight digital-to-analog converters (DACs) for audio output. This translates to twelve channels of audio in and twenty four channels of audio out. The codec/extender can input and output data at a sample rate of up to 192 kHz on all channels.

The audio interface connections are shown in [Figure 2-2](#); more details can be found in [“SHARC Audio EZ-Extender Schematic” on page B-1](#). The three codec chips (referred to as “AD1939A”, “AD1939B”, and “AD1939C”) connect in parallel to the serial peripheral interface (SPI) port of the ADSP-21469 SHARC processor via the DPI pins. The SPI port of the processor is used to adjust volume and other audio parameters of each of the three codecs.

The serial ports (SPORTs) are used to transmit and receive audio data to and from the processor via the DAI pins. The analog audio channels are available via single-ended RCA connectors (J2–7) or differential DB25 connectors (P1–5). By default, the extender is shipped with the RCA connectors used by the AD1939 codecs for audio in and out. P1–5 are used to switch to differential mode. A standard, off the shelf DB25 connector to XLR cables is required to operate in differential mode. The P1–5 connectors require five XLR cables for full functionality. The XLR cables are not provided with the EZ-Extender. The mating cable’s manufacturer and part number information can be found in [“Differential In/Out Connectors \(P1–5\)” on page 2-18](#).

The DAI pins of the master codec can be configured to transfer serial data from the codec in Time-Division Multiplexing (TDM) mode or Integrated Interchip Sound (I<sup>2</sup>S) mode. The master input clock (MCLK) of the codec is generated by the on-board 12.288 MHz oscillator. The internal PLL of the codec is used to generate varying sample rates. The codec can be set up for 48 KHz, 96 KHz, or 192 KHz frequencies. The master codec (codec A) can run at these frequencies in both TDM and I<sup>2</sup>S modes with all ADCs inputs and DACs outputs. Codecs B and C are wired on the EZ-Extender and allow TDM mode operations only.

- At a 48 kHz sample rate, TDM mode allows up to 16 channels of data to be sent from each chip in each direction. Each chip uses four of the 16 input channels and eight of the 16 output channels.



The number of channels can be set up in the control registers and is dependent on the sample rate. As the sample rate increases, the number of possible channels decreases.

- At 96 kHz, the AD1939 operates with a maximum of eight channels in each direction. At 96 kHz, all of the TDM channels are used by all analog outputs, but there are still four extra input channels, two of which can be used by the digital inputs.
- At the 192 kHz sample rate, a maximum of four channels in each direction can be used, meaning that four of the output channels cannot be used. To run at 192 KHz with all ADCs and DACs in TDM mode, the codec must run in dual-line TDM mode.

For more information about the AD1939 codecs, go to <http://www.analog.com> and search for AD1939.

Example programs are included in the EZ-Extender installation directory to demonstrate how to configure and use the board's analog audio interface.

For more information, see “[System Architecture](#)” on page 2-2, “[Configuration Switches](#)” on page 2-5, “[Power LED](#)” on page 2-16, and “[Connectors](#)” on page 2-17.

## Example Programs

Example programs are provided with the SHARC Audio EZ-Extender to demonstrate various capabilities of the product. The programs are installed with the VisualDSP++ 5.0 update 7 or later software and can be found in the `<install_path>\214xx\Examples\SHARC Audio EZ-Extender` directory. Refer to the readme file provided with each example for more information



# 2 SHARC AUDIO EZ-EXTENDER HARDWARE REFERENCE

This chapter describes the hardware design of the SHARC Audio EZ-Extender.

The following topics are covered.

- [“System Architecture” on page 2-2](#)  
Describes the daughter board’s configuration and explains how the board components interface with the processor and EZ-Board.
- [“Configuration Switches” on page 2-5](#)  
Shows the locations and describes the on-board configuration switches.
- [“Power LED” on page 2-16](#)  
Shows the location and describes the on-board power LED.
- [“Connectors” on page 2-17](#)  
Shows the locations, describes, and provides part numbers for the on-board connectors. In addition, the manufacturer and part number information is provided for the mating parts.

# System Architecture

A block diagram of the SHARC Audio EZ-Extender is shown in [Figure 2-1](#).

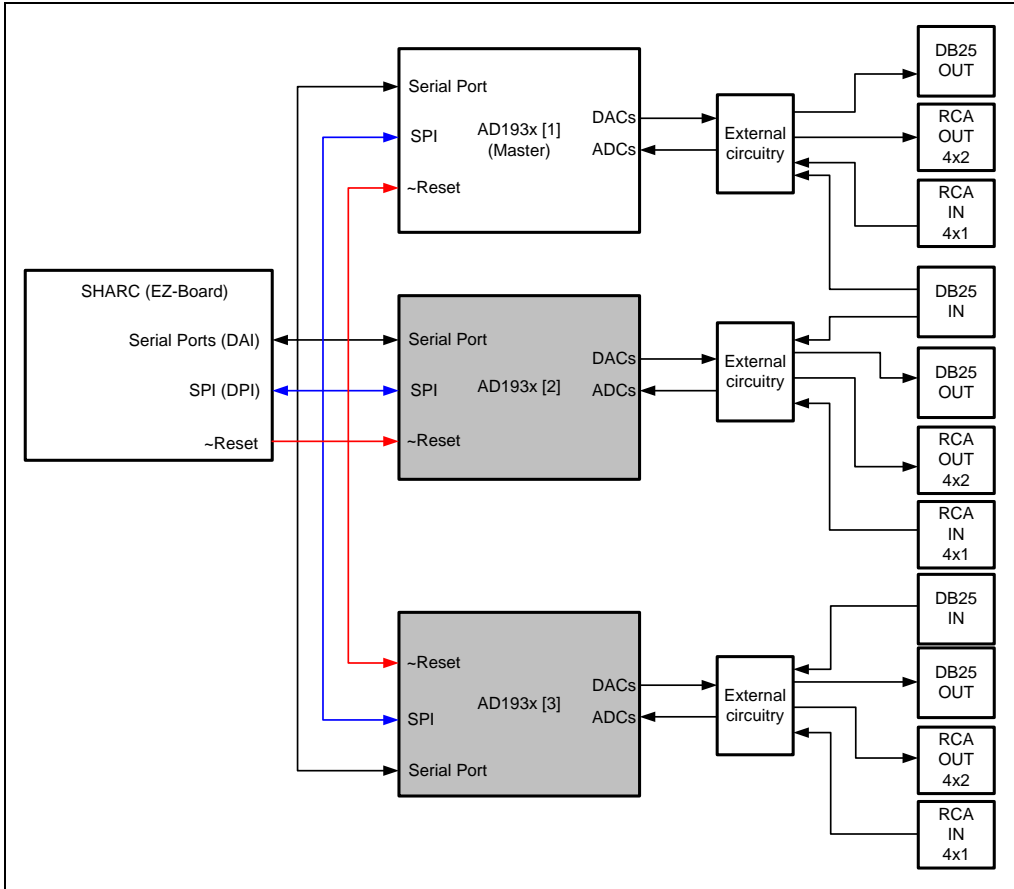

Figure 2-1. SHARC Audio EZ-Extender Block Diagram

# SHARC Audio EZ-Extender Hardware Reference

Figure 2-2 is a block diagram of the audio interface; the diagram illustrates how the serial ports are interfaced to the processor and AD1939 codecs on a mating SHARC EZ-Board. The block diagram is a high-level diagram and does not show the voltage translation circuitry or clock buffers. The schematic pages are available in “SHARC Audio EZ-Extender Schematic” on page B-1.

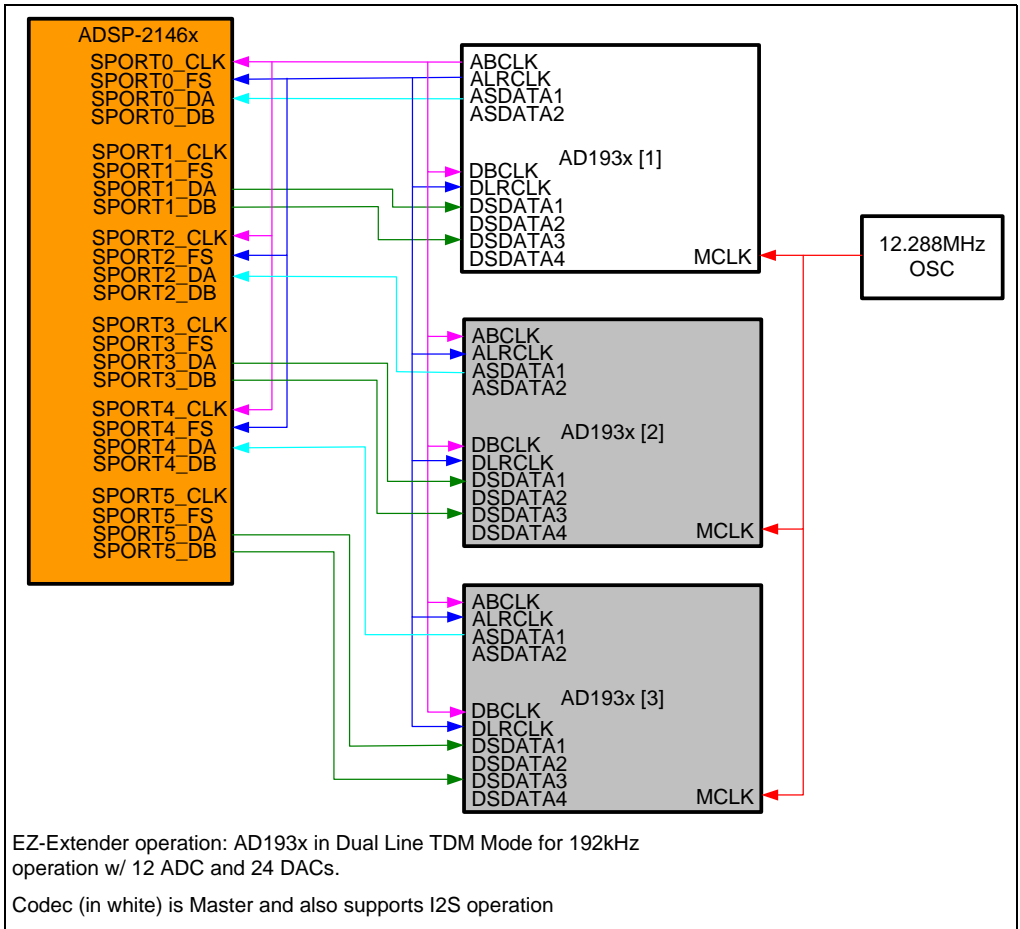

Figure 2-2. Serial Port Configuration Block Diagram

## System Architecture

The analog audio interface consists of three AD1939 audio codec ICs (referred to as “AD1939A”, “AD1939B”, and “AD1939C”), which use up to six serial ports (SPORTs) of the processor. All of the clock and frame sync signals of the processor are driven by the master AD1939 codec (AD1939A).

The master codec can run in either Time-Division Multiplexed (TDM) mode or Integrated Interchip Sound (I<sup>2</sup>S) mode at a 48 KHz, 96 KHz, or 192 KHz sample rate in both modes using only two serial ports. Codecs B and C are connected to be slaves only and are hard-wired on the EZ-Extender to run in dual-line TDM. Codecs B and C can run in conjunction with codec A using six of the processor’s eight serial ports for dual-line TDM operation at a 192 KHz sample rate. In all cases, the processor is wired to be a slave, and the serial port clock and frame syncs are generated by the master codec (AD1939A).

Each of the Audio EZ-Extender’s codecs is configured using the SPI port of the processor. Each codec includes its own chip select pin.

The SHARC Audio EZ-Extender also is equipped with a 2-wire I<sup>2</sup>C serial flash memory device (M24C02). The M24C02 memory can store up to 2 KB of data, which includes a section pre-programmed with board revision data (PCB revision, BOM revision, serial number, etc.) and allows software to search for board-specific information at runtime. The flash memory device is connected to the EZ-Board via DPI pins 7 and 8. The address of the two-wire device can be modified using the DIP switch on the Audio EZ-Extender; see [“Memory Configuration Switch \(SW19\)” on page 2-14](#) for more information.

## Configuration Switches

This section describes operation of the configuration switches. Before using the SHARC Audio EZ-Extender, follow the steps documented in the readme text files in the `<install_path>\214xx\Examples\SHARC Audio EZ-Extender` directories of VisualDSP++ 5.0 update 7 or later. The switch locations are shown in [Figure 2-3](#). Switches on the bottom side of the EZ-Extender board are shown with a dashed line.

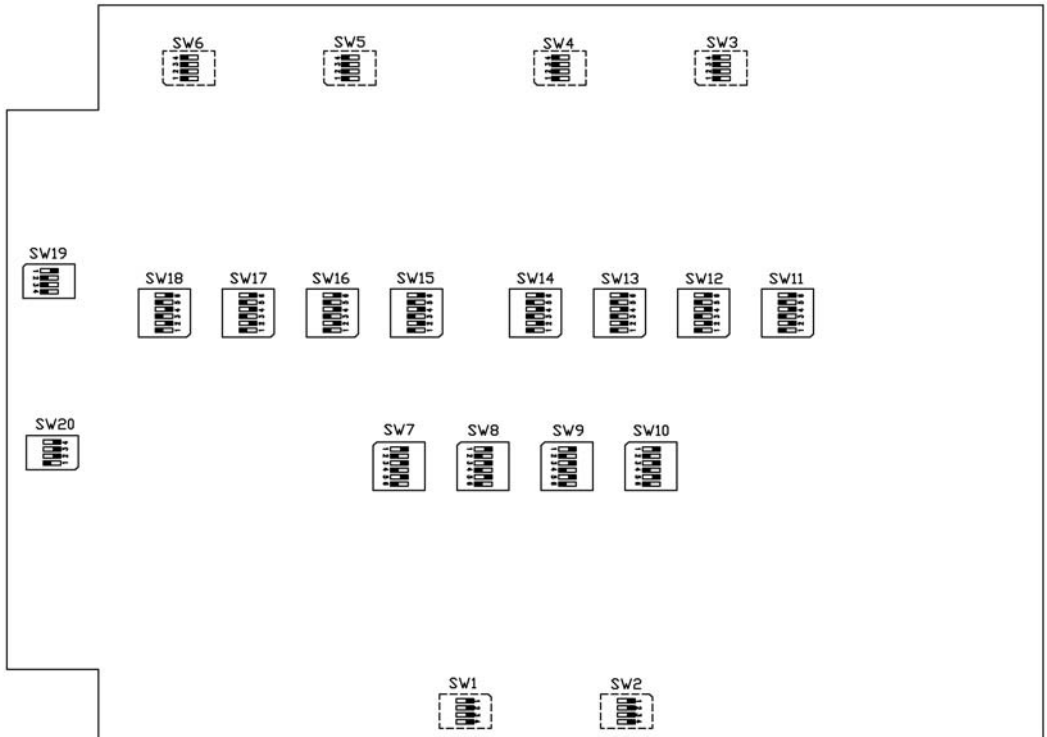

Figure 2-3. Switch Locations

## Configuration Switches

### Audio Loopback Switches (SW1–6)

The audio loopback switches (SW1–6) are intended for test purposes only. The switches loop-back any analog output signal generated from an AD1939 codec’s digital-to-analog converter (DAC) circuit to analog-to-digital converter (ADC) circuit:

- SW1–2 are designed for the master codec (AD1939A)
- SW3–4 are designed for the secondary codec (AD1939B)
- SW5–6 are designed for the third codec (AD1939C)

By default, switches SW1–6 are all OFF.

### Audio In1 Left Selection Switch (SW7)

The audio selection switch (SW7) connects the left channel of the In1 line, connected to the AD1939’s ADC1 circuit, to either the single-ended RCA connectors or the differential DB25 connector. By default, the switch is set up to use the RCA connectors. The switch circuit is connected to AD1939A (codec A). To use the standard, off the shelf DB25 connector to XLR cables, change the switch to the differential setting; see [Table 2-1](#). See also “[Differential In/Out Connectors \(P1–5\)](#)” on page 2-18.

Table 2-1. Audio In1 Left Selection Switch (SW7)

| SW7 Position | Single-Ended Mode<br>RCA IN (Default) | Differential Mode<br>DB25 IN (P1) |
|--------------|---------------------------------------|-----------------------------------|
| SW7.1        | ON                                    | OFF                               |
| SW7.2        | OFF                                   | ON                                |
| SW7.3        | ON                                    | OFF                               |
| SW7.4        | OFF                                   | ON                                |



Table 2-1. Audio In1 Left Selection Switch (SW7) (Cont'd)

| SW7 Position | Single-Ended Mode<br>RCA IN (Default) | Differential Mode<br>DB25 IN (P1) |
|--------------|---------------------------------------|-----------------------------------|
| SW7.5        | ON                                    | OFF                               |
| SW7.6        | OFF                                   | ON                                |

## Audio In1 Right Selection Switch (SW8)

The audio selection switch (SW8) connects the right channel of the In1 line, connected to the AD1939's ADC2 circuit, to either the single-ended RCA connectors or the differential DB25 connector. By default, the switch is set up to use the RCA connectors for audio in. The switch circuit is connected to AD1939A (codec A). To use the standard, off the shelf DB25 connector to XLR cables, change the switch to the differential setting; see [Table 2-2](#). See also [“Differential In/Out Connectors \(P1–5\)” on page 2-18](#).

Table 2-2. Audio In1 Right Selection Switch (SW8)

| SW8 Position | Single-Ended Mode<br>RCA IN (Default) | Differential Mode<br>DB25 IN (P1) |
|--------------|---------------------------------------|-----------------------------------|
| SW8.1        | ON                                    | OFF                               |
| SW8.2        | OFF                                   | ON                                |
| SW8.3        | ON                                    | OFF                               |
| SW8.4        | OFF                                   | ON                                |
| SW8.5        | ON                                    | OFF                               |
| SW8.6        | OFF                                   | ON                                |

### Audio In2 Left Selection Switch (SW9)

The audio selection switch (SW9) connects the left channel of the In2 line, connected to the AD1939's ADC3 circuit, to either the single-ended RCA connectors or the differential DB25 connector. By default, the switch is set up to use the RCA connectors. The switch circuit is connected to AD1939A (codec A). To use the standard, off the shelf DB25 connector to XLR cables, change the switch to the differential setting; see [Table 2-3](#). See also “[Differential In/Out Connectors \(P1–5\)](#)” on page 2-18.

Table 2-3. Audio In2 Left Selection Switch (SW9)

| SW9 Position | Single-Ended Mode<br>RCA IN (Default) | Differential Mode<br>DB25 IN (P1) |
|--------------|---------------------------------------|-----------------------------------|
| SW9.1        | ON                                    | OFF                               |
| SW9.2        | OFF                                   | ON                                |
| SW9.3        | ON                                    | OFF                               |
| SW9.4        | OFF                                   | ON                                |
| SW9.5        | ON                                    | OFF                               |
| SW9.6        | OFF                                   | ON                                |

### Audio In2 Right Selection Switch (SW10)

The audio selection switch (SW10) connects the right channel of the In2 line, connected to the AD1939's ADC4 circuit, to either the single-ended RCA connectors or the differential DB25 connector. By default, the switch is set up to use the RCA connectors for audio in. The switch circuit is connected to AD1939A (codec A). To use the standard, off the shelf DB25 connector to XLR cables, change the switch to the differential setting; see [Table 2-4](#). See also “[Differential In/Out Connectors \(P1–5\)](#)” on page 2-18.

Table 2-4. Audio In2 Right Selection Switch (SW10)

| SW10 Position | Single-Ended Mode<br>RCA IN (Default) | Differential Mode<br>DB25 IN (P1) |
|---------------|---------------------------------------|-----------------------------------|
| SW10.1        | ON                                    | OFF                               |
| SW10.2        | OFF                                   | ON                                |
| SW10.3        | ON                                    | OFF                               |
| SW10.4        | OFF                                   | ON                                |
| SW10.5        | ON                                    | OFF                               |
| SW10.6        | OFF                                   | ON                                |

## Audio In3 Left Selection Switch (SW11)

The audio selection switch (SW11) connects the left channel of the In3 line, connected to the AD1939's ADC5 circuit, to either the single-ended RCA connectors or the differential DB25 connector. By default, the switch is set up to use the RCA connectors. The switch circuit is connected to AD1939B (codec B). To use the standard, off the shelf DB25 connector to XLR cables, change the switch to the differential setting; see [Table 2-5](#). See also "[Differential In/Out Connectors \(P1–5\)](#)" on page 2-18.

Table 2-5. Audio In3 Left Selection Switch (SW11)

| SW11 Position | Single-Ended Mode<br>RCA IN (Default) | Differential Mode<br>DB25 IN (P1) |
|---------------|---------------------------------------|-----------------------------------|
| SW11.1        | ON                                    | OFF                               |
| SW11.2        | OFF                                   | ON                                |
| SW11.3        | ON                                    | OFF                               |
| SW11.4        | OFF                                   | ON                                |
| SW11.5        | ON                                    | OFF                               |
| SW11.6        | OFF                                   | ON                                |

### Audio In3 Right Selection Switch (SW12)

The audio selection switch (SW12) connects the right channel of the In3 line, connected to the AD1939's ADC6 circuit, to either the single-ended RCA connectors or the differential DB25 connector. By default, the switch is set up to use the RCA connectors for audio in. The switch circuit is connected to AD1939B (codec B). To use the standard, off the shelf DB25 connector to XLR cables, change the switch to the differential setting; see [Table 2-6](#). See also “[Differential In/Out Connectors \(P1–5\)](#)” on [page 2-18](#).

Table 2-6. Audio In3 Right Selection Switch (SW12)

| SW12 Position | Single-Ended Mode<br>RCA IN (Default) | Differential Mode<br>DB25 IN (P1) |
|---------------|---------------------------------------|-----------------------------------|
| SW12.1        | ON                                    | OFF                               |
| SW12.2        | OFF                                   | ON                                |
| SW12.3        | ON                                    | OFF                               |
| SW12.4        | OFF                                   | ON                                |
| SW12.5        | ON                                    | OFF                               |
| SW12.6        | OFF                                   | ON                                |

### Audio In4 Left Selection Switch (SW13)

The audio selection switch (SW13) connects the left channel of the In4 line, connected to the AD1939's ADC7 circuit, to either the single-ended RCA connectors or the differential DB25 connector. By default, the switch is set up to use the RCA connectors. The switch circuit is connected to AD1939B (codec B). To use the standard, off the shelf DB25 connector to XLR cables, change the switch to the differential setting; see [Table 2-7](#). See also “[Differential In/Out Connectors \(P1–5\)](#)” on [page 2-18](#).

Table 2-7. Audio In4 Left Selection Switch (SW13)

| SW13 Position | Single-Ended Mode<br>RCA IN (Default) | Differential Mode<br>DB25 IN (P1) |
|---------------|---------------------------------------|-----------------------------------|
| SW13.1        | ON                                    | OFF                               |
| SW13.2        | OFF                                   | ON                                |
| SW13.3        | ON                                    | OFF                               |
| SW13.4        | OFF                                   | ON                                |
| SW13.5        | ON                                    | OFF                               |
| SW13.6        | OFF                                   | ON                                |

## Audio In4 Right Selection Switch (SW14)

The audio selection switch (SW14) connects the right channel of the In4 line, connected to the AD1939’s ADC8 circuit, to either the single-ended RCA connectors or the differential DB25 connector. By default, the switch is set up to use the RCA connectors for audio in. The switch circuit is connected to AD1939B (codec B). To use the standard, off the shelf DB25 connector to XLR cables, change the switch to the differential setting; see [Table 2-8](#). See also “[Differential In/Out Connectors \(P1–5\)](#)” on [page 2-18](#).

Table 2-8. Audio In4 Right Selection Switch (SW14)

| SW14 Position | Single-Ended Mode<br>RCA IN (Default) | Differential Mode<br>DB25 IN (P1) |
|---------------|---------------------------------------|-----------------------------------|
| SW14.1        | ON                                    | OFF                               |
| SW14.2        | OFF                                   | ON                                |
| SW14.3        | ON                                    | OFF                               |
| SW14.4        | OFF                                   | ON                                |
| SW14.5        | ON                                    | OFF                               |
| SW14.6        | OFF                                   | ON                                |

### Audio In5 Left Selection Switch (SW15)

The audio selection switch (SW15) connects the left channel of the In5 line, connected to the AD1939's ADC9 circuit, to either the single-ended RCA connectors or the differential DB25 connector. By default, the switch is set up to use the RCA connectors. The switch circuit is connected to AD1939C (codec C). To use the standard, off the shelf DB25 connector to XLR cables, change the switch to the differential setting; see [Table 2-9](#). See also [“Differential In/Out Connectors \(P1–5\)”](#) on page 2-18.

Table 2-9. Audio In5 Left Selection Switch (SW15)

| SW15 Position | Single-Ended Mode<br>RCA IN (Default) | Differential Mode<br>DB25 IN (P2) |
|---------------|---------------------------------------|-----------------------------------|
| SW15.1        | ON                                    | OFF                               |
| SW15.2        | OFF                                   | ON                                |
| SW15.3        | ON                                    | OFF                               |
| SW15.4        | OFF                                   | ON                                |
| SW15.5        | ON                                    | OFF                               |
| SW15.6        | OFF                                   | ON                                |

### Audio In5 Right Selection Switch (SW16)

The audio selection switch (SW16) connects the right channel of the In5 line, connected to the AD1939's ADC10 circuit, to either the single-ended RCA connectors or the differential DB25 connector. By default, the switch is set up to use the RCA connectors for audio in. The switch circuit is connected to AD1939C (codec C). To use the standard, off the shelf DB25 connector to XLR cables, change the switch to the differential setting; see [Table 2-10](#). See also [“Differential In/Out Connectors \(P1–5\)”](#) on page 2-18.

Table 2-10. Audio In5 Right Selection Switch (SW16)

| SW16 Position | Single-Ended Mode<br>RCA IN (Default) | Differential Mode<br>DB25 IN (P2) |
|---------------|---------------------------------------|-----------------------------------|
| SW16.1        | ON                                    | OFF                               |
| SW16.2        | OFF                                   | ON                                |
| SW16.3        | ON                                    | OFF                               |
| SW16.4        | OFF                                   | ON                                |
| SW16.5        | ON                                    | OFF                               |
| SW16.6        | OFF                                   | ON                                |

## Audio In6 Left Selection Switch (SW17)

The audio selection switch (SW17) connects the left channel of the In6 line, connected to the AD1939’s ADC11 circuit, to either the single-ended RCA connectors or the differential DB25 connector. By default, the switch is set up to use the RCA connectors. The switch circuit is connected to AD1939C (codec C). To use the standard, off the shelf DB25 connector to XLR cables, change the switch to the differential setting; see [Table 2-11](#). See also [“Differential In/Out Connectors \(P1–5\)” on page 2-18](#).

Table 2-11. Audio In6 Left Selection Switch (SW17)

| SW17 Position | Single-Ended Mode<br>RCA IN (Default) | Differential Mode<br>DB25 IN (P2) |
|---------------|---------------------------------------|-----------------------------------|
| SW17.1        | ON                                    | OFF                               |
| SW17.2        | OFF                                   | ON                                |
| SW17.3        | ON                                    | OFF                               |
| SW17.4        | OFF                                   | ON                                |
| SW17.5        | ON                                    | OFF                               |
| SW17.6        | OFF                                   | ON                                |

### Audio In8 Right Selection Switch (SW18)

The audio selection switch (SW18) connects the right channel of the In8 line, connected to the AD1939's ADC12 circuit, to either the single-ended RCA connectors or the differential DB25 connector. By default, the switch is set up to use the RCA connectors for audio in. The switch circuit is connected to AD1939C (codec C). To use the standard, off the shelf DB25 connector to XLR cables, change the switch to the differential setting; see [Table 2-12](#). See also “[Differential In/Out Connectors \(P1–5\)](#)” on [page 2-18](#).

Table 2-12. Audio In8 Right Selection Switch (SW18)

| SW18 Position | Single-Ended Mode<br>RCA IN (Default) | Differential Mode<br>DB25 IN (P2) |
|---------------|---------------------------------------|-----------------------------------|
| SW18.1        | ON                                    | OFF                               |
| SW18.2        | OFF                                   | ON                                |
| SW18.3        | ON                                    | OFF                               |
| SW18.4        | OFF                                   | ON                                |
| SW18.5        | ON                                    | OFF                               |
| SW18.6        | OFF                                   | ON                                |

### Memory Configuration Switch (SW19)

The memory configuration switch (SW19) settings are shown in [Table 2-13](#). For more information on the memory functionality, refer to the memory manufacturer's datasheet. By default, the memory write protection is on and as a result, the device select and address bytes are acknowledged, but the data bytes are not. In order to write to the memory device, turn the DIP switch (SW19.1) OFF.



Table 2-13. Memory Configuration Switch (SW19)

| SW19 Position | Function         | Switch Setting (Default) |
|---------------|------------------|--------------------------|
| SW19.1        | Write protection | ON                       |
| SW19.2        | ADDR0            | OFF                      |
| SW19.3        | ADDR1            | OFF                      |
| SW19.4        | ADDR2            | OFF                      |

## Soft Reset Enable Switch (SW20)

The software reset enable switch (SW20) settings are shown in [Table 2-14](#). The switch resets all three AD1939 codecs simultaneously via a programmable flag pin.

By default, FLAG0 is enabled and can be used to reset the three codecs. FLAG1, FLAG2, or FLAG3 also can be used (in place of FLAG0) to reset the codecs via software by changing the respective SW20 pins. To reset all three codecs via a single reset supervisor on the EZ-Board, turn all positions of SW20 to OFF.

If a soft reset is required, only one position of SW20 can be enabled at any given time.

Table 2-14. Soft Reset Enable Switch (SW20)

| SW20 Position | Processor Flag Pin | Switch Setting (Default) |
|---------------|--------------------|--------------------------|
| SW20.1        | FLAG0              | ON                       |
| SW20.2        | FLAG1              | OFF                      |
| SW20.3        | FLAG1              | OFF                      |
| SW20.4        | FLAG3              | OFF                      |

## Power LED

This section describes the power LED (LED1) When LED1 is lit solid, it indicates that the board is powered. [Figure 2-4](#) shows the LED location.

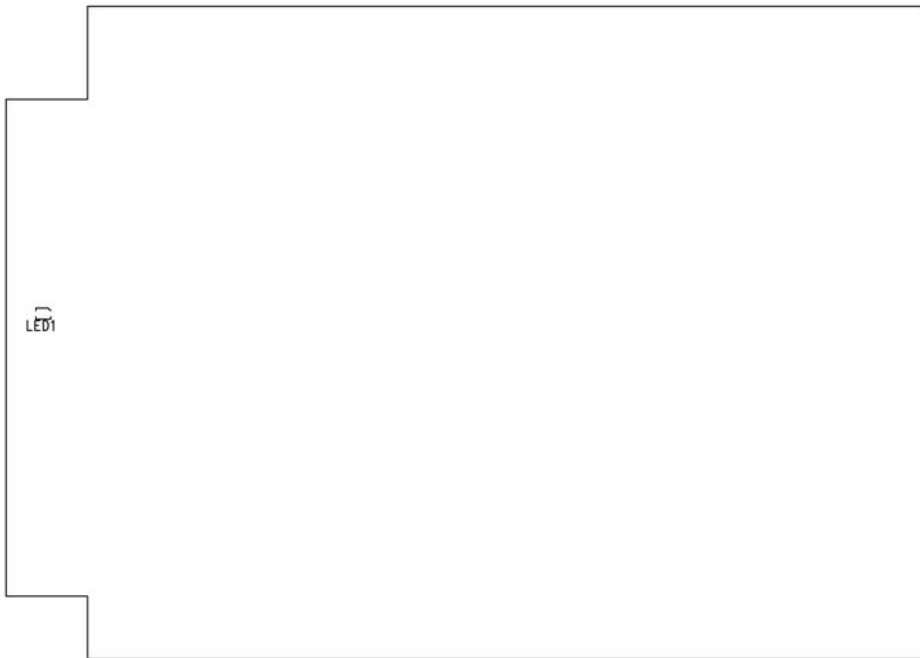

Figure 2-4. Power LED Location

## Connectors

This section describes connector functionality and provides information about mating connectors. The connector locations are shown in [Figure 2-5](#). Dashed lines denote connectors located on the bottom side of the board.

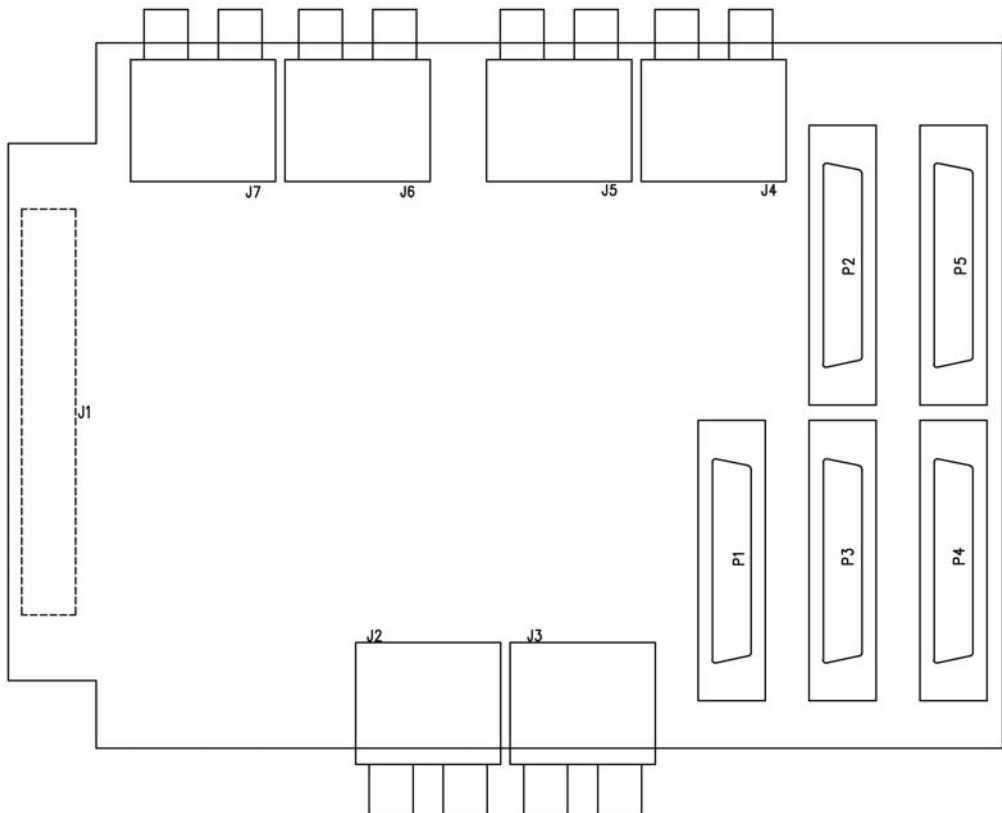

Figure 2-5. Connector Locations

## Connectors

### Expansion Interface II Connector (J1)

The board-to-board connector (J1) providing signals for the DAI and DPI interfaces and general-purpose I/O (GPIO) signals of the mating EZ-Board. J1 also provides the EZ-Extender's power. Consequently, no extra power supply is needed when using the product. The connector is located on the left edge of the board. For availability and pricing of the connector, contact Samtec.

| Part Description             | Manufacturer | Part Number        |
|------------------------------|--------------|--------------------|
| 60-position 0.1", SMT socket | SAMTEC       | SSW-130-22-F-D-VS  |
| <b>Mating Connector</b>      |              |                    |
| 60-position 0.1", SMT header | SAMTEC       | TSSH-130-01-L-DV-A |

### RCA Audio Connectors (J2-7)

Analog audio channels via single-ended RCA connectors (J2-7).

| Part Description                                   | Manufacturer | Part Number  |
|--|--------------|--------------|
| RCA 2 x 3  | KYOYAKU ENT  | WSP-256V1-09 |
| <b>Mating Cable (shipped with the EZ-Extender)</b> |              |              |
| 6' RCA audio cable                                 | CABLESTOGO   | 03171        |

### Differential In/Out Connectors (P1-5)

The differential in and out connectors (P1-5) are intended for an evaluation of the AD1939 codecs via XLR connectors. A standard, off the shelf DB25 connector to XLR cables is required.

## SHARC Audio EZ-Extender Hardware Reference

| Part Description        | Manufacturer | Part Number   |
|-------------------------|--------------|---------------|
| 25-position DB25 socket | FCI          | D25S24AGX00LF |
| <b>Mating Cable</b>     |              |               |
| Snake (8)XLR-F-25P 9.9' | HOSA         | DTF-803       |
| Snake (8)XLR-M-25P 9.9' | HOSA DTM     | DTM-803       |

## Connectors

# A SHARC AUDIO EZ-EXTENDER BILL OF MATERIALS

The bill of materials corresponds to “SHARC Audio EZ-Extender Schematic” on page B-1.

| Ref. | Qty. | Description             | Reference Designator | Manufacturer      | Part Number            |
|------|------|-------------------------|----------------------|-------------------|------------------------|
| 1    | 1    | 12.288MHZ<br>OSC003     | U1                   | EPSON             | SG-8002CA MP           |
| 2    | 3    | SN74LVC1G08<br>SOT23-5  | U57-59               | TI                | SN74LVC1G08DBVR        |
| 3    | 3    | SN74AVC8T245<br>TSSOP24 | U54-56               | TI                | SN74AVC8T245PW         |
| 4    | 1    | IDT5T30553<br>SOIC8     | U2                   | IDT               | 5T30553DCG             |
| 5    | 2    | PCK3807A<br>TSSOP20     | U60-61               | NXP               | PCK3807APW             |
| 6    | 3    | AD1939 LQFP64           | U3-5                 | ANALOG<br>DEVICES | AD1939YSTZ             |
| 7    | 48   | AD8652ARZ<br>SOIC_N8    | U6-53                | ANALOG<br>DEVICES | AD8652ARZ              |
| 8    | 1    | ADP1715 MSOP8           | VR1                  | ANALOG<br>DEVICES | ADP1715ARMZ-<br>3.3-R7 |
| 9    | 12   | DIP6 SWT017             | SW7-18               | CTS               | 218-6LPST              |
| 10   | 8    | DIP4 SWT018             | SW1-6,SW19-20        | ITT               | TDA04HOSB1             |
| 11   | 6    | RCA 2x3<br>CON_RCA_6B   | J2-7                 | KYOYAKU<br>ENT.   | WSP-256V1-09H          |
| 12   | 5    | DB25 25PIN<br>DB25FV    | P1-5                 | FCI               | D25S24AGX00LF          |

| Ref. | Qty. | Description               | Reference Designator  | Manufacturer | Part Number       |
|------|------|---------------------------|---|--------------|-------------------|
| 13   | 1    | IDC 30x2<br>IDC30X2_SMT_F | J1  | SAMTEC       | SSW-130-22-F-D-VS |
| 14   | 6    | 10UF 6.3V 10%<br>0805     | C17,C20,C113,C116,<br>C211,C214   | AVX          | 08056D106KAT2A    |
| 15   | 74   | 0.1UF 10V 10%<br>0402     | C24,C32,C34-35,C40,<br>C42,C46-47,C52,C64-<br>67,C73-75,C78,C87-8<br>9,C92,C101-103,C107,<br>C130,C132-133,C138,<br>C140,C144-145,C150,<br>C162-165,C171-173,<br>C176,C185-187,C190,<br>C199-201,C205,C228,<br>C230-231,C236,C238,<br>C242-243,C248,C260-<br>263,C269-271,C274,<br>C283-285,C288,C297-<br>299,C303, | AVX          | 0402ZD104KAT2A    |
| 16   | 34   | 0.01UF 16V 10%<br>0402    | C1-16,C23,C112,<br>C119-124,C210,C217-<br>222,C308,C311,C313  | AVX          | 0402YC103KAT2A    |
| 17   | 14   | 10K 1/16W 5%<br>0402      | R1-2,R22,R24-29,R43-<br>44,R617-619   | VISHAY       | CRCW040210K0FKED  |
| 18   | 44   | 33 1/16W 5%<br>0402       | R3-21,R23,R30-42,<br>R46-49,R237,R425,R6<br>12-616  | VISHAY       | CRCW040233R0JNEA  |
| 19   | 3    | 100UF 10V 10%<br>C        | CT2,CT43,CT84   | AVX          | TPSC107K010R0075  |
| 20   | 2    | 2.2UF 10V 10%<br>0805     | C25-26  | AVX          | 0805ZD225KAT2A    |
| 21   | 1    | 1A SK12<br>DO-214AA       | D2  | DIODES INC   | B120B-13-F        |
| 22   | 6    | 0.1UF 16V<br>10%0603      | C18-19,C114-115,<br>C212-213  | AVX          | 0603YC104KAT2A    |



## SHARC Audio EZ-Extender Bill Of Materials

| Ref. | Qty. | Description            | Reference Designator  | Manufacturer | Part Number      |
|------|------|------------------------|---|--------------|------------------|
| 23   | 1    | 330 1/10W 5%<br>0603   | R622  | VISHAY       | CRCW0603330RJNEA |
| 24   | 24   | 237.0 1/10W 1%<br>0603 | R53,R57,R65,R68,<br>R77,R80-81,R84,R241,<br>R245,R253,R256,<br>R265,R268-269,R272,<br>R429,R433,R441,<br>R444,R453,R456-457,<br>R460  | DIGI-KEY     | 311-237HRTR-ND   |
| 25   | 72   | 49.9K 1/10W 1%<br>0603 | R50,R56,R67,R71,<br>R79,R82,R90-92,<br>R118-119,R127-128,<br>R147-148,R155,R164,<br>R183-184,R191,R200,<br>R219-220,R227,R238,<br>R244,R255,R259,<br>R267,R270,R278-280,<br>R306-307,R315-316,<br>R335-336,R343,R352,<br>R371-372,R379,R388,<br>R407-408,R415,R426,<br>R432,R443,R447,<br>R455,R458,R466-468,<br>R494-4 | DIGI-KEY     | 311-49.9KHRTR-ND |
| 26   | 3    | 562.0 1/10W 1%<br>0603 | R45,R236,R424   | VISHAY       | CRCW0603562RFKEA |
| 27   | 3    | 390PF 25V 5%<br>0603   | C21,C117,C215   | AVX          | 06033A391FAT2A   |
| 28   | 3    | 5600PF 16V 5%<br>0805  | C22,C118,C216   | AVX          | 0805YA562JAT2A   |

| Ref. | Qty. | Description         | Reference Designator  | Manufacturer | Part Number      |
|------|------|---------------------|---|--------------|------------------|
| 29   | 120  | 4.99K 1/16W 1% 0603 | R51,R58,R63-64,R75-76,R85-86,R93,R95-96,R106,R108-110,R126,R133-134,R136-138,R141,R150,R157,R169-170,R172-174,R177,R186,R193,R205-206,R208-210,R213,R222,R229,R239,R246,R251-252,R263-264,R273-274,R281,R283-284,R294,R296-298,R314,R321-322,R324-326,R329,R338 | VISHAY       | CRCW06034K99FKEA |
| 30   | 6    | 10UF 10V 10% 0805   | C41,C139,C237,C309-310,C312   | PANASONIC    | ECJ-2FB1A106K    |
| 31   | 24   | 5.76K 1/16W 1% 0603 | R52,R55,R62,R66,R74,R78,R83,R87,R240,R243,R250,R254,R262,R266,R271,R275,R428,R431,R438,R442,R450,R454,R459,R463   | PANASONIC    | ERJ-3EKF5761V    |
| 32   | 1    | GREEN LED001        | LED1  | PANASONIC    | LN1361CTR        |
| 33   | 3    | 1.0K 1/16W 1% 0402  | R70,R258,R446   | PANASONIC    | ERJ-2RKF1001X    |
| 34   | 24   | 100K 1/16W 5% 0402  | R121-122,R151-152,R187-188,R223,R225,R309-310,R339-340,R375-376,R411,R413,R497-498,R527-528,R563-564,R599,R601  | DIGI-KEY     | 541-100KJTR-ND   |

## SHARC Audio EZ-Extender Bill Of Materials

| Ref. | Qty. | Description            | Reference Designator   | Manufacturer | Part Number     |
|------|------|------------------------|--|--------------|-----------------|
| 35   | 48   | 2.67K 1/16W 1%<br>0402 | R98,R100,R104,R120,<br>R153-154,R159,R163,<br>R189-190,R195,R199,<br>R224,R226,R231,<br>R235,R286,R288,<br>R292,R308,R341-342,<br>R347,R351,R377-378,<br>R383,R387,R412,<br>R414,R419,R423,<br>R474,R476,R480,<br>R496,R529-530,R535,<br>R539,R565-566,R571,<br>R575,R600,R602,<br>R607,R611 | PANASONIC    | ERJ-2RKF2671X   |
| 36   | 84   | 100.0 1/16W 1%<br>0402 | R59-60,R72,R89,<br>R113-117,R124,R135,<br>R142-146,R171,R178-<br>182,R207,R214-218,<br>R247-248,R260,R277,<br>R301-305,R312,R323,<br>R330-334,R359,R366-<br>370,R395,R402-406,<br>R435-436,R448,R465,<br>R489-493,R500,R511,<br>R518-522,R547,R554-<br>558,R583,R590-594                     | DIGI-KEY     | 541-100LCT-ND   |
| 37   | 12   | 37.4K 1/16W 1%<br>0402 | R54,R61,R73,R88,<br>R242,R249,R261,<br>R276,R430,R437,<br>R449,R464  | DIGI-KEY     | 541-37.4KLCT-ND |
| 38   | 24   | 1000PF 50V 5%<br>0402  | C27-28,C33,C39,C45,<br>C48,C54-55,C125-<br>126,C131,C137,C143,<br>C146,C152-153,C223-<br>224,C229,C235,C241,<br>C244,C250-251  | DIGI-KEY     | 490-3244-1-ND   |

| Ref. | Qty. | Description            | Reference Designator  | Manufacturer | Part Number            |
|------|------|------------------------|---|--------------|------------------------|
| 39   | 12   | 100pF 50V 5%<br>0402   | C31,C37,C44,C50,<br>C129,C135,C142,<br>C148,C227,C233,<br>C240,C246   | MURATA       | GCM1555C1H101JZ1<br>3D |
| 40   | 24   | 300PF 100V 5%<br>0603  | C29-30,C36,C38,C43,<br>C49,C51,C53,C127-<br>128,C134,C136,C141,<br>C147,C149,C151,<br>C225-226,C232,C234,<br>C239,C245,C247,<br>C249  | DIGI-KEY     | 490-1362-2-ND          |
| 41   | 48   | 2.43K 1/16W 1%<br>0402 | R97,R101,R105,R107,<br>R130-131,R160-161,<br>R166-167,R196-197,<br>R202-203,R232-233,<br>R285,R289,R293,<br>R295,R318-319,R348-<br>349,R354-355,R384-<br>385,R390-391,R420-<br>421,R473,R477,R481,<br>R483,R506-507,R536-<br>537,R542-543,R572-<br>573,R578-579,R608-<br>609                        | DIGI-KEY     | 541-2.43KLCT-ND        |
| 42   | 48   | 750.0 1/16W 1%<br>0402 | R99,R102-103,R125,<br>R129,R132,R158,<br>R162,R165,R168,<br>R194,R198,R201,<br>R204,R230,R234,<br>R287,R290-291,R313,<br>R317,R320,R346,<br>R350,R353,R356,<br>R382,R386,R389,<br>R392,R418,R422,<br>R475,R478-479,R501,<br>R505,R508,R534,<br>R538,R541,R544,<br>R570,R574,R577,<br>R580,R606,R610 | DIGI-KEY     | 541-750LCT-ND          |

## SHARC Audio EZ-Extender Bill Of Materials

| Ref. | Qty. | Description               | Reference Designator  | Manufacturer | Part Number     |
|------|------|---------------------------|---|--------------|-----------------|
| 43   | 48   | 620PF 50V 5%<br>0402      | C57,C62-63,C68,C70-71,C76,C80,C84-85,C90,C94,C98-99,C104,C108,C155,C160-161,C166,C168-169,C174,C178,C182-183,C188,C192,C196-197,C202,C206,C253,C258-259,C264,C266-267,C272,C276,C280-281,C286,C290,C294-295,C300,C304 | DIGI-KEY     | 490-3239-1-ND   |
| 44   | 48   | 680PF 50V 5%<br>0402      | C58-59,C61,C69,C77,C79,C82-83,C91,C93,C96-97,C105-106,C110-111,C156-157,C159,C167,C175,C177,C180-181,C189,C191,C194-195,C203-204,C208-209,C254-255,C257,C265,C273,C275,C278-279,C287,C289,C292-293,C301-302,C306-307  | DIGI-KEY     | 490-3240-1-ND   |
| 45   | 120  | 22UF 6.3V 20%<br>ELEC_4MM | CT1,CT3-42,CT44-83,CT85-123   | PANASONIC    | EEE-FC0J220R    |
| 46   | 24   | 22UF 6.3V 20%<br>ELEC_5MM | C56,C60,C72,C81,C86,C95,C100,C109,C154,C158,C170,C179,C184,C193,C198,C207,C252,C256,C268,C277,C282,C291,C296,C305   | MOUSER       | 647-UWP0J220MCL |

| Ref. | Qty. | Description            | Reference Designator   | Manufacturer | Part Number      |
|------|------|------------------------|--|--------------|------------------|
| 47   | 48   | 6.81K 1/10W 1%<br>0603 | R94,R111-112,R123,<br>R139-140,R149,R156,<br>R175-176,R185,R192,<br>R211-212,R221,R228,<br>R282,R299-300,R311,<br>R327-328,R337,R344,<br>R363-364,R373,R380,<br>R399-400,R409,R416,<br>R470,R487-488,R499,<br>R515-516,R525,R532,<br>R551-552,R561,R568,<br>R587-588,R597,R604 | DIGI-KEY     | 311-6.81KHRTR-ND |
| 48   | 3    | 806 1/10W 1%<br>0402   | R69,R257,R445  | VISHAY       | CRCW0402806RFKED |
| 49   | 1    | 30A GSOT03<br>SOT23-3  | D1   | VISHAY       | GSOT03-GS08      |

A

B

C

D

1

1

2

2

3

3

4

4

# SHARC AUDIO EZ-EXTENDER SCHEMATIC

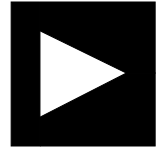

**ANALOG  
DEVICES**

20 Cotton Road  
Nashua, NH 03063  
PH: 1-800-ANALOGD

|                  |                  |                                  |                   |
|------------------|------------------|----------------------------------|-------------------|
| <b>Title</b>     |                  | SHARC AUDIO EZ-EXTENDER<br>TITLE |                   |
| <b>Size</b><br>C | <b>Board No.</b> | A0223-2008                       | <b>Rev</b><br>0.1 |
| <b>Date</b>      | 5-7-2009_9:31    | <b>Sheet</b>                     | 1 of 24           |

A

B

C

D

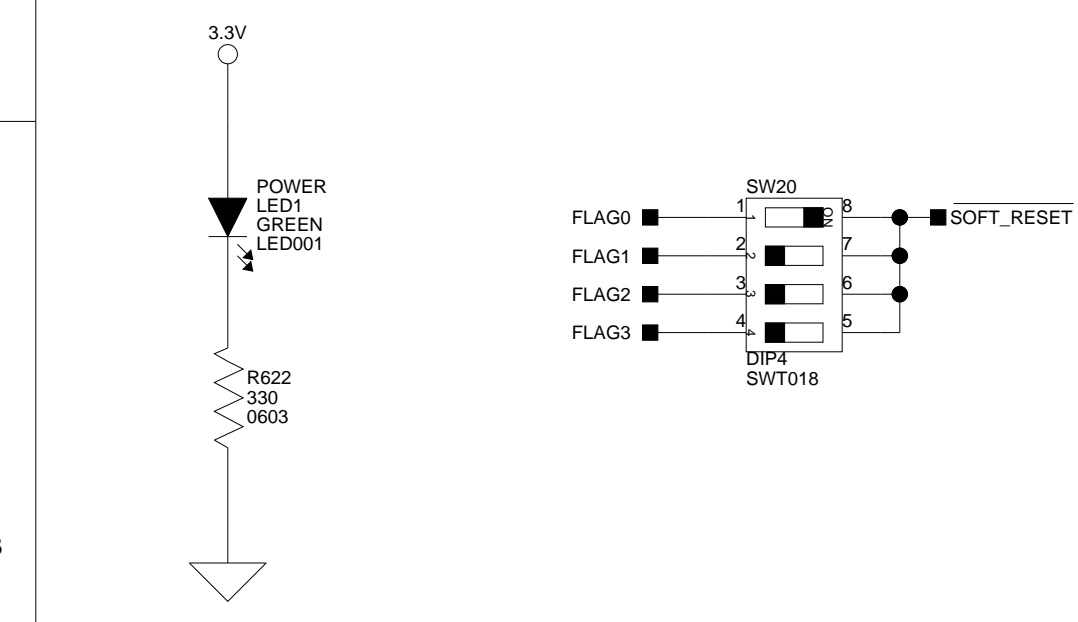
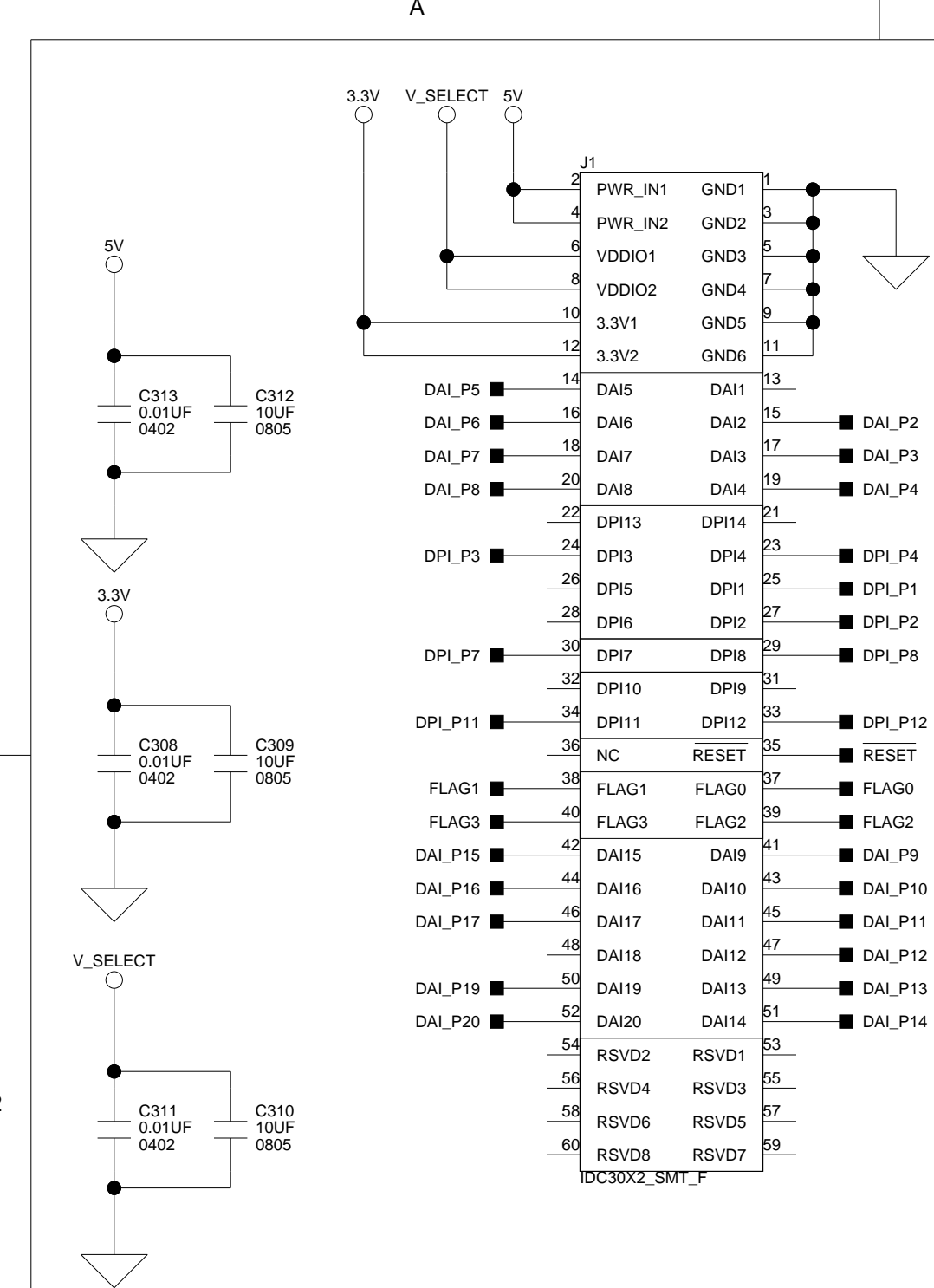

| DSP PIN NAME | PERIPHERAL NET CONNECTED TO | DSP PIN NAME | PERIPHERAL NET CONNECTED TO |
|--------------|-----------------------------|--------------|-----------------------------|
| DAI_P1       | NOT USED                    | DPI_P1       | SPI_MOSI                    |
| DAI_P2       | AD1939A_ABCLK               | DPI_P2       | SPI_MISO                    |
| DAI_P3       | AD1939C_DSDDATA3            | DPI_P3       | SPI_CLK                     |
| DAI_P4       | AD1939C_DSDDATA1            | DPI_P4       | AD1939A_CS                  |
| DAI_P5       | AD1939A_ASDDATA1            | DPI_P5       | NOT USED                    |
| DAI_P6       | AD1939A_ASDDATA2            | DPI_P6       | NOT USED                    |
| DAI_P7       | AD1939A_ABCLK               | DPI_P7       | I2C_SDA                     |
| DAI_P8       | AD1939A_ALRCLK              | DPI_P8       | I2C_SCK                     |
| DAI_P9       | AD1939A_DSDDATA4            | DPI_P9       | NOT USED                    |
| DAI_P10      | AD1939A_DSDDATA3            | DPI_P10      | NOT USED                    |
| DAI_P11      | AD1939A_DSDDATA2            | DPI_P11      | AD1939B_CS                  |
| DAI_P12      | AD1939A_DSDDATA1            | DPI_P12      | AD1939C_CS                  |
| DAI_P13      | AD1939B_DSDDATA3            | DPI_P13      | NOT USED                    |
| DAI_P14      | AD1939B_DSDDATA1            | DPI_P14      | NOT USED                    |
| DAI_P15      | AD1939B_ASDDATA1            |              |                             |
| DAI_P16      | AD1939C_ASDDATA1            |              |                             |
| DAI_P17      | AD1939A_ABCLK               |              |                             |
| DAI_P18      | NOT USED                    |              |                             |
| DAI_P19      | AD1939A_ALRCLK              |              |                             |
| DAI_P20      | AD1939A_ALRCLK              |              |                             |

NOTE: DIP SWITCHES ON THE EZ-BOARD MAY NEED TO BE TURNED OFF TO USE THEM ON THIS EZ-EXTENDER

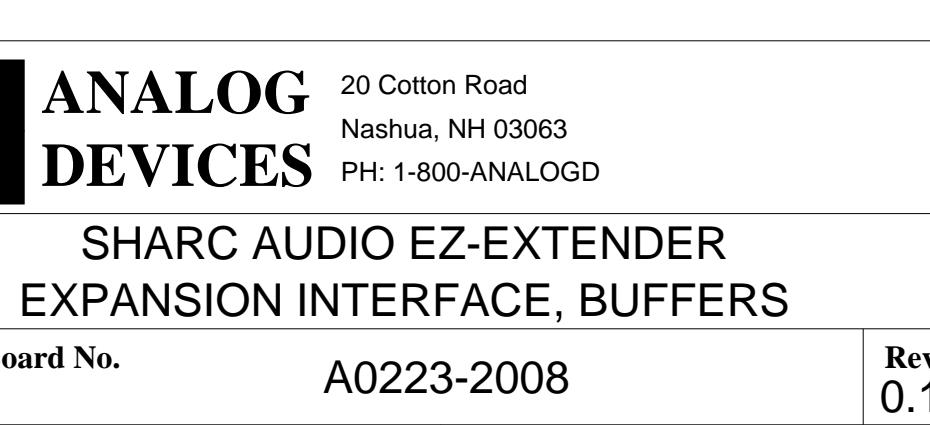
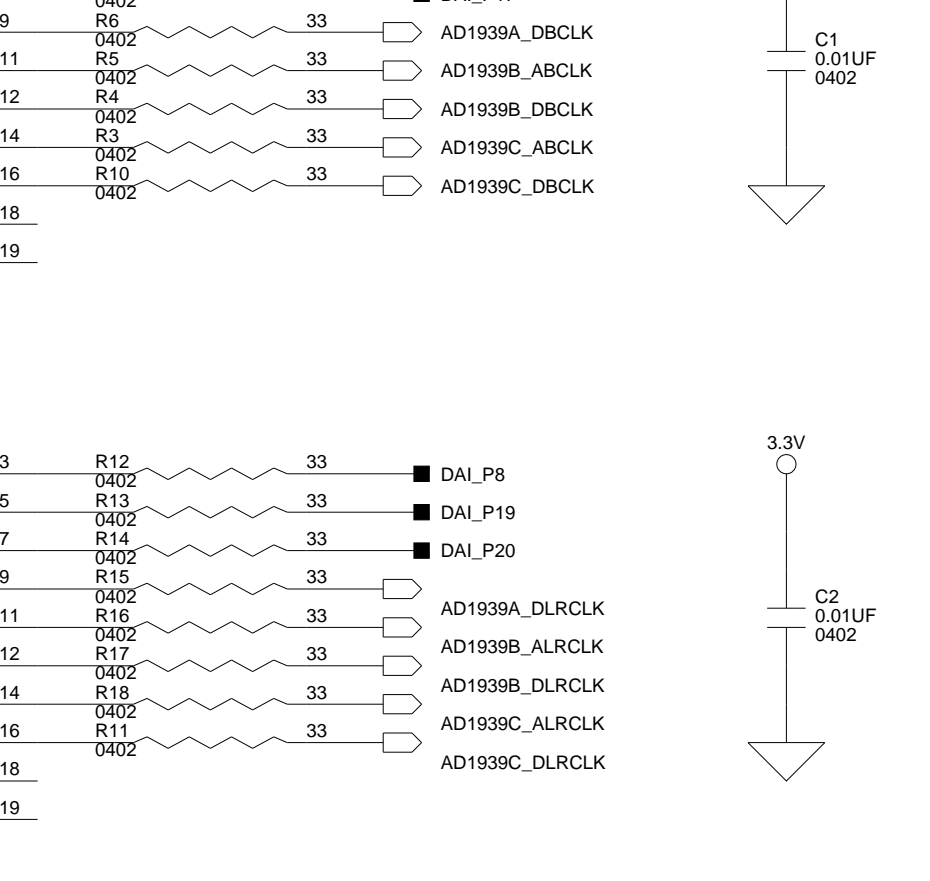
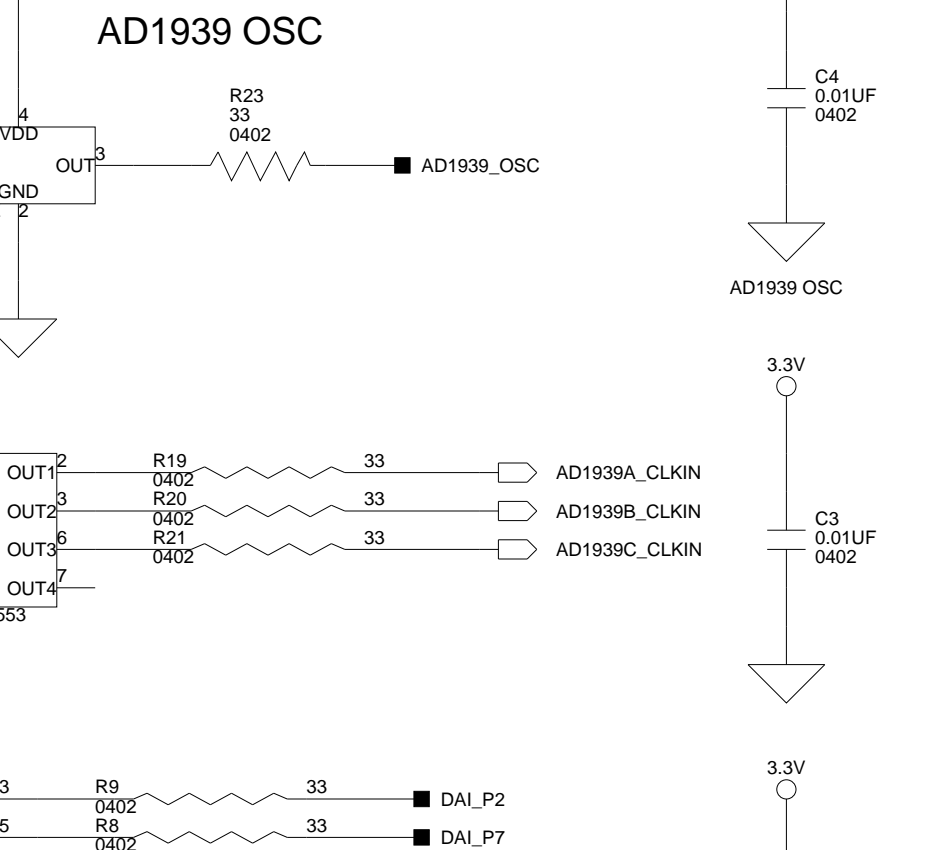
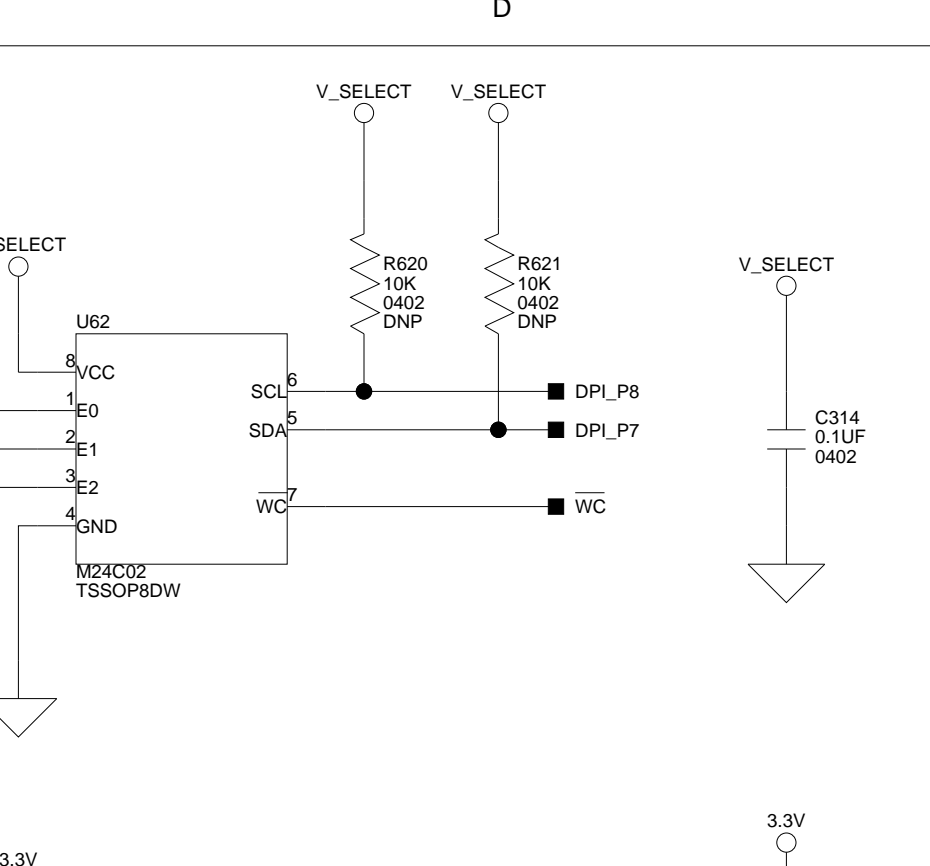
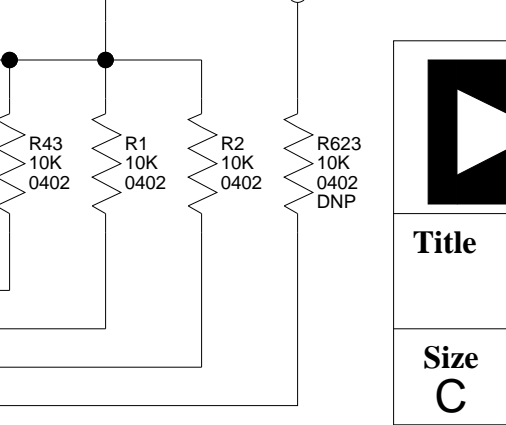
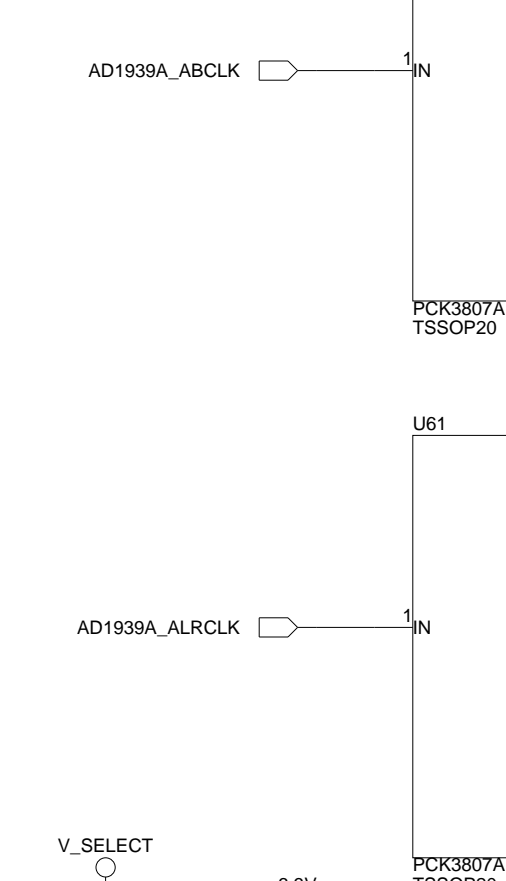
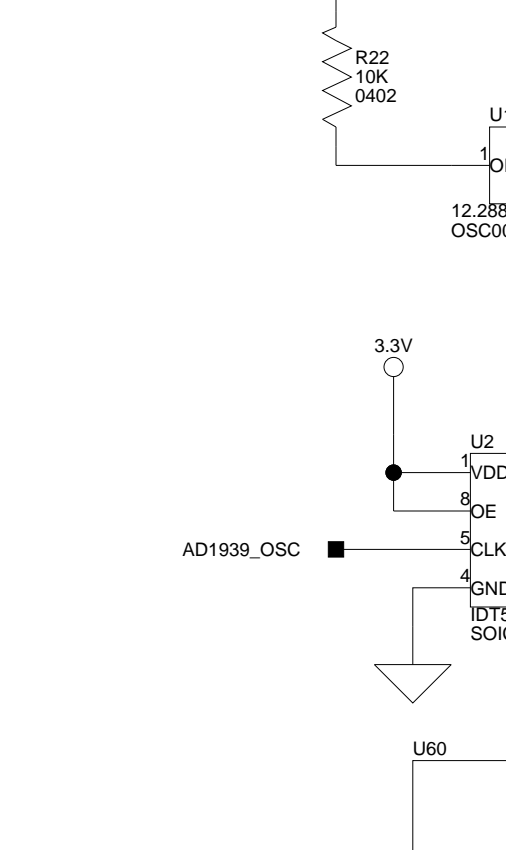
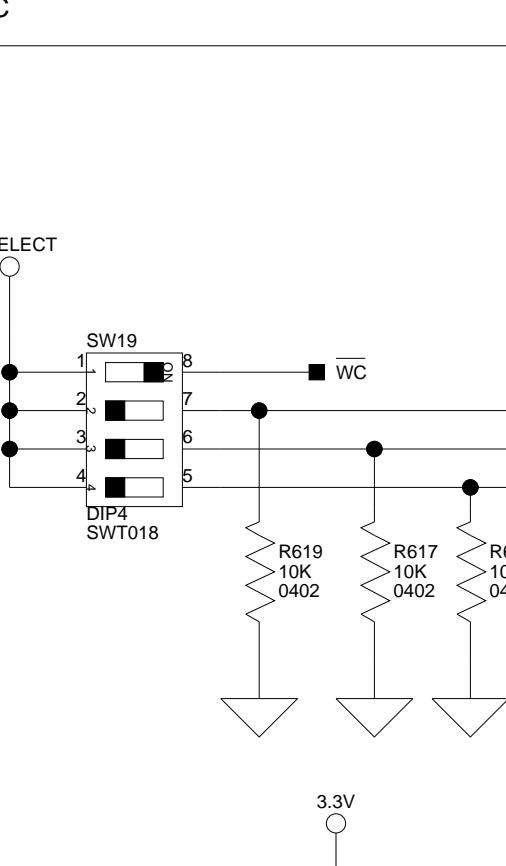
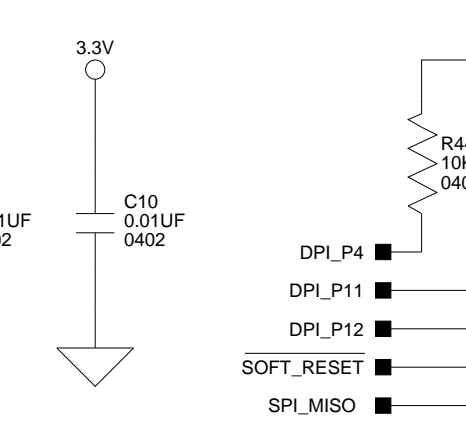
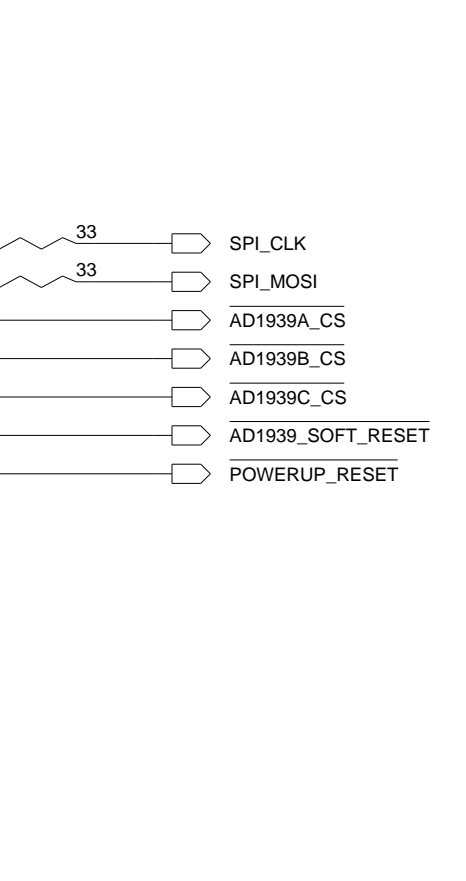
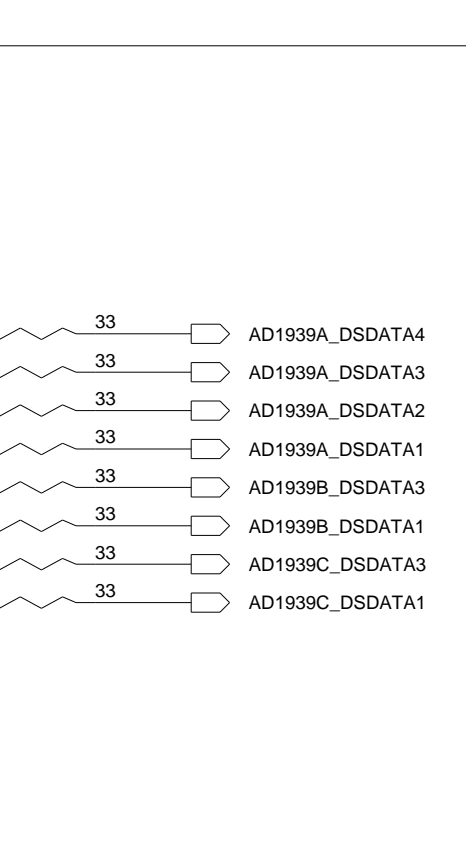
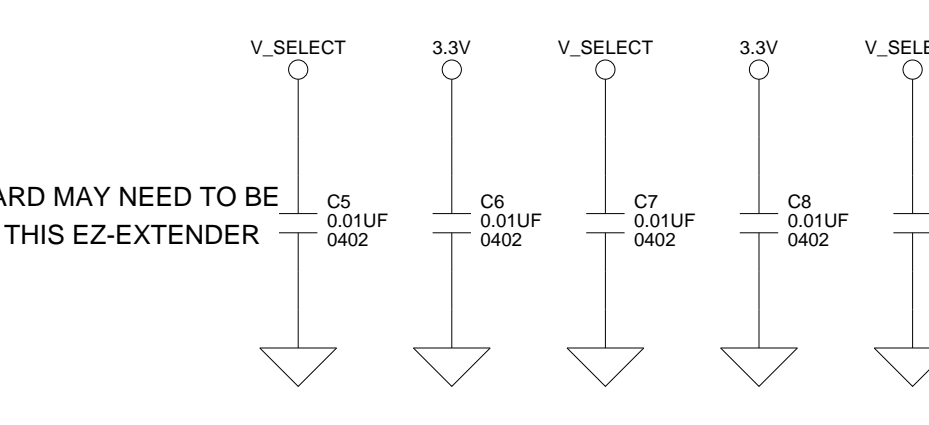
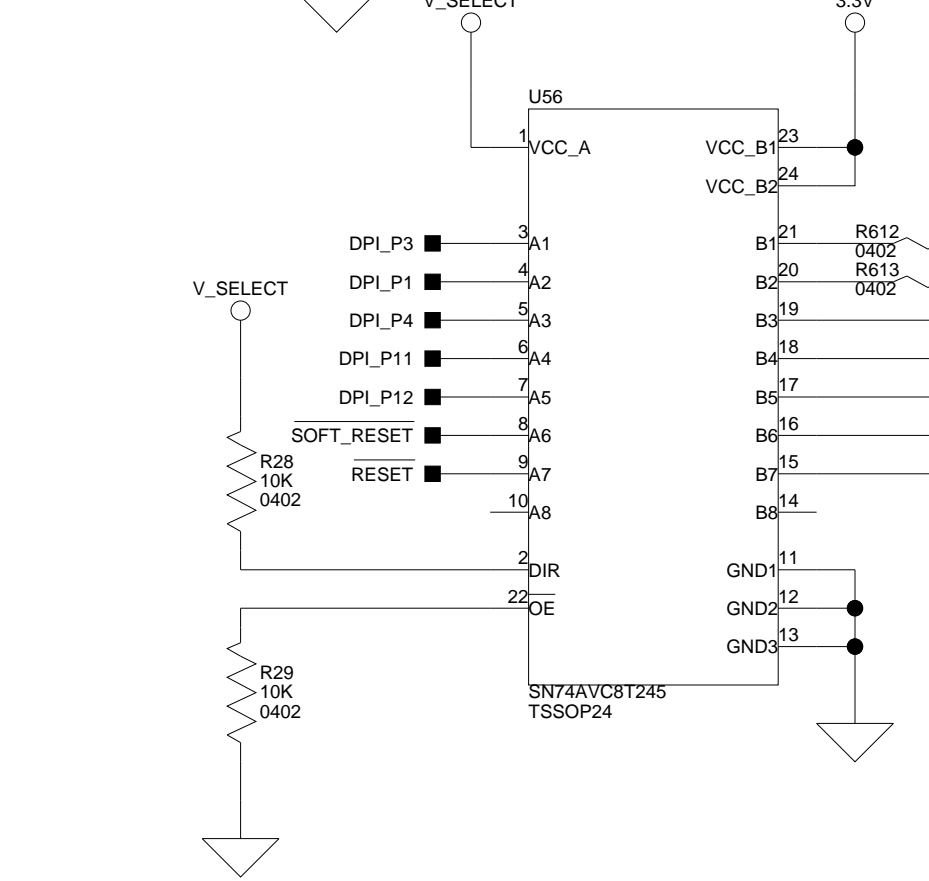
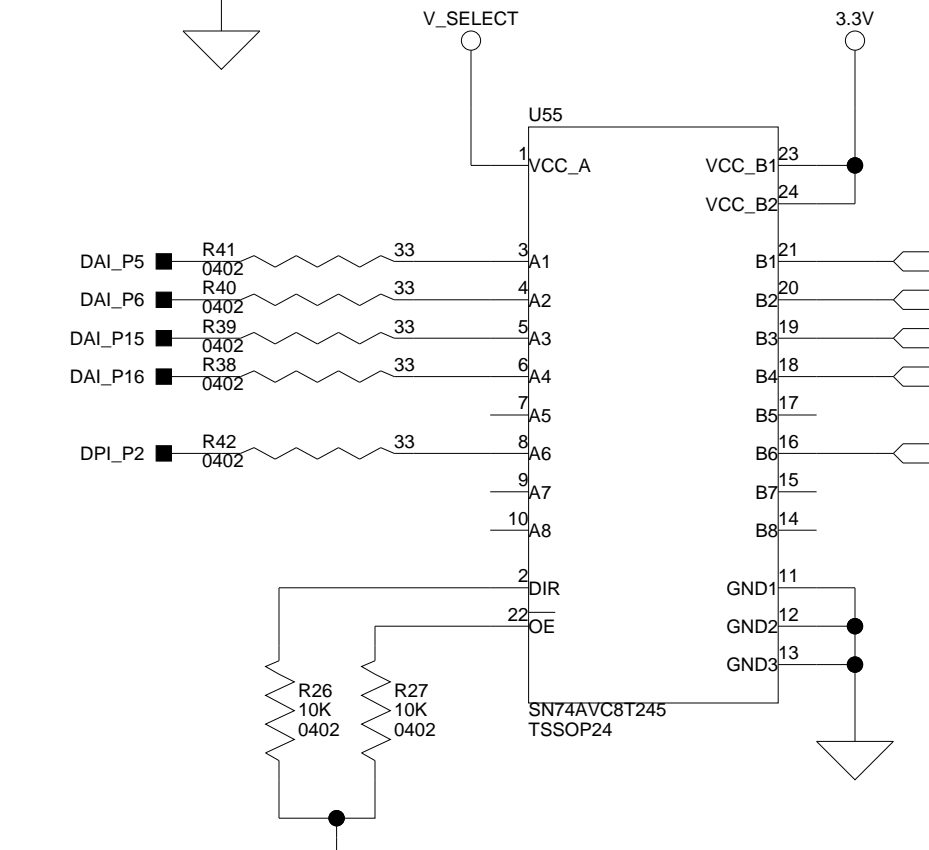
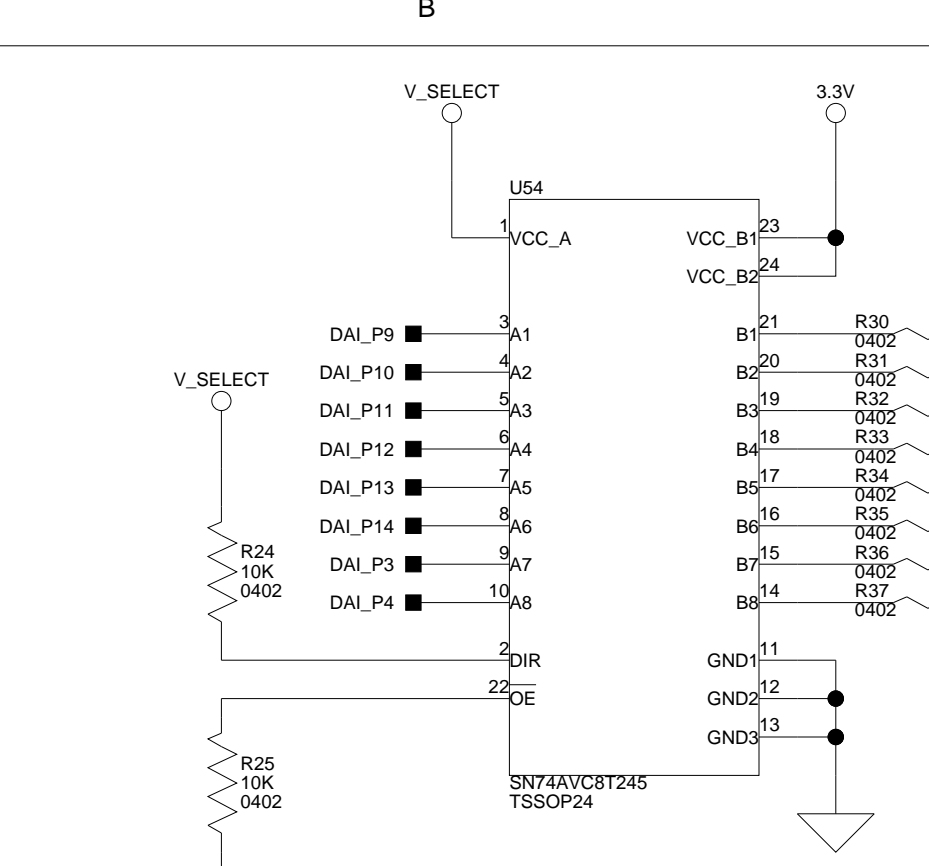

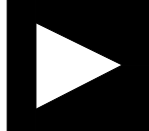

**ANALOG DEVICES**

20 Cotton Road  
Nashua, NH 03063  
PH: 1-800-ANALOGD

|  |                             |                |  |
|--|-----------------------------|----------------|--|
| <b>Title</b> SHARC AUDIO EZ-EXTENDER<br>EXPANSION INTERFACE, BUFFERS |                             |                |  |
| <b>Size C</b>  | <b>Board No.</b> A0223-2008 | <b>Rev</b> 0.1 |  |
| <b>Date</b> 6-9-2009_15:31   | <b>Sheet</b> 2 of 24        |                |  |



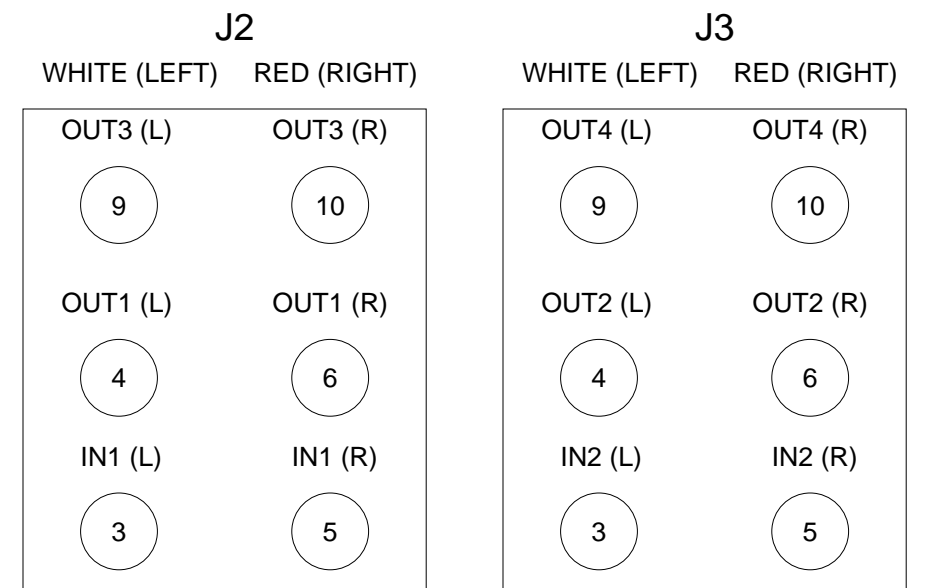
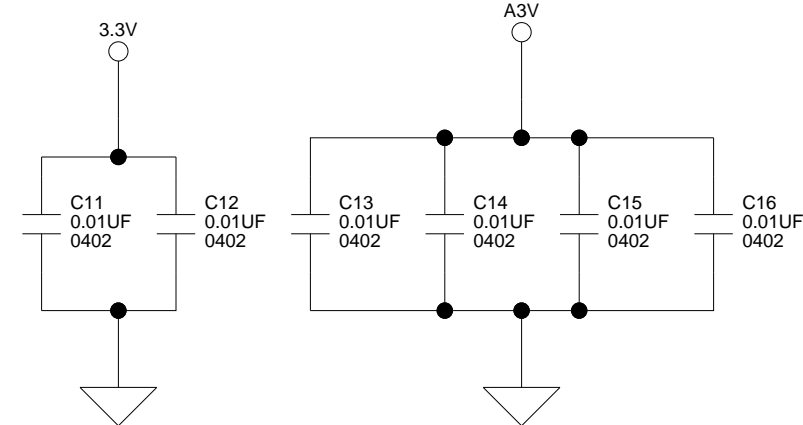
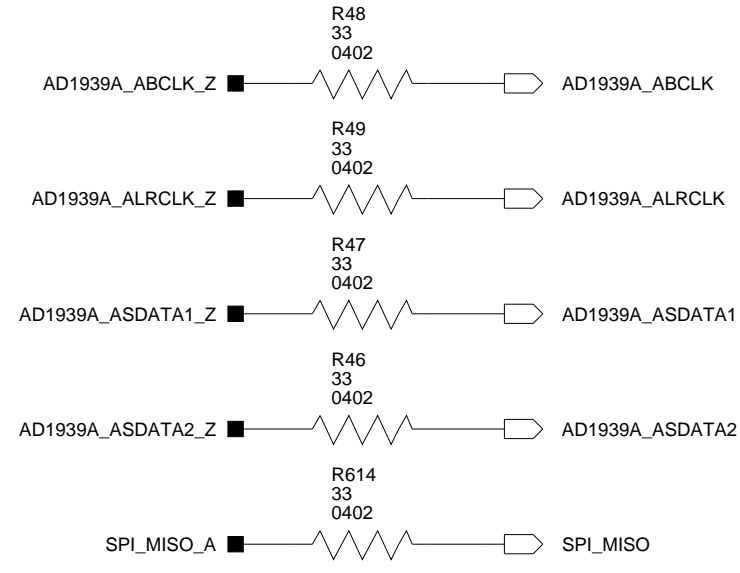
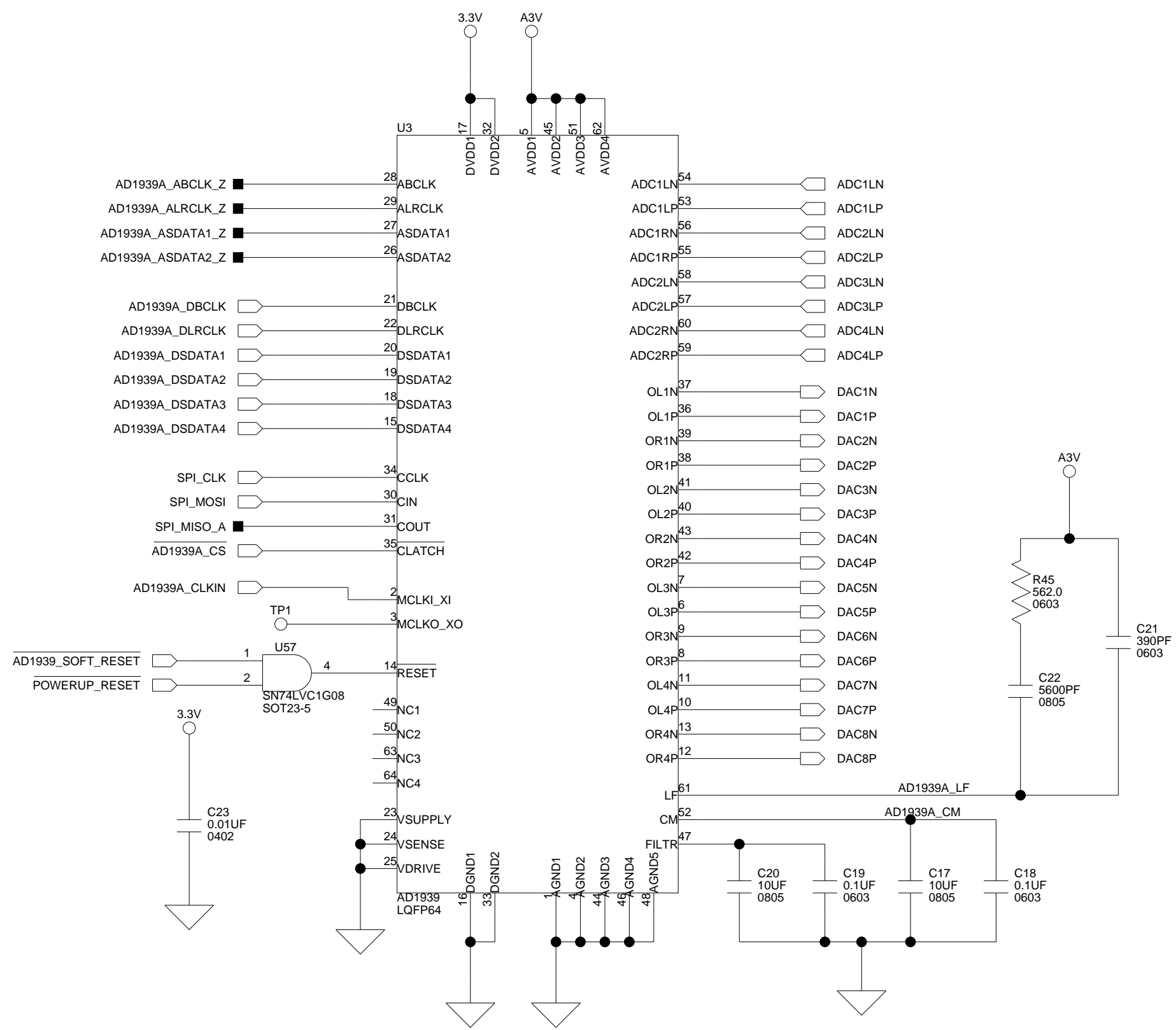

NOTE: THE NUMBER INSIDE EACH OF THE CIRCLES IS THE ACTUAL PIN NUMBER FOR THE RESPECTIVE CONNECTOR.

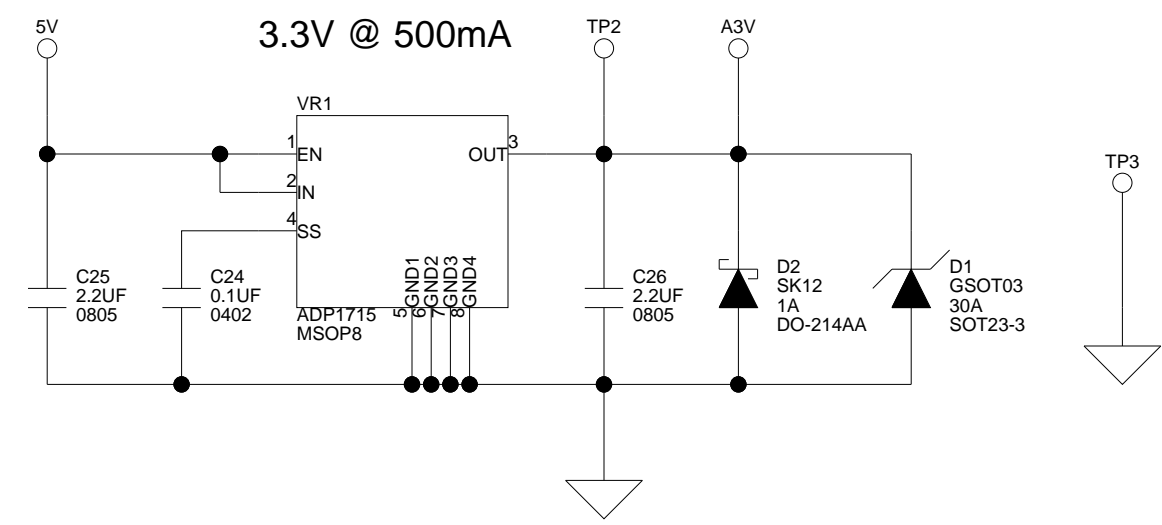
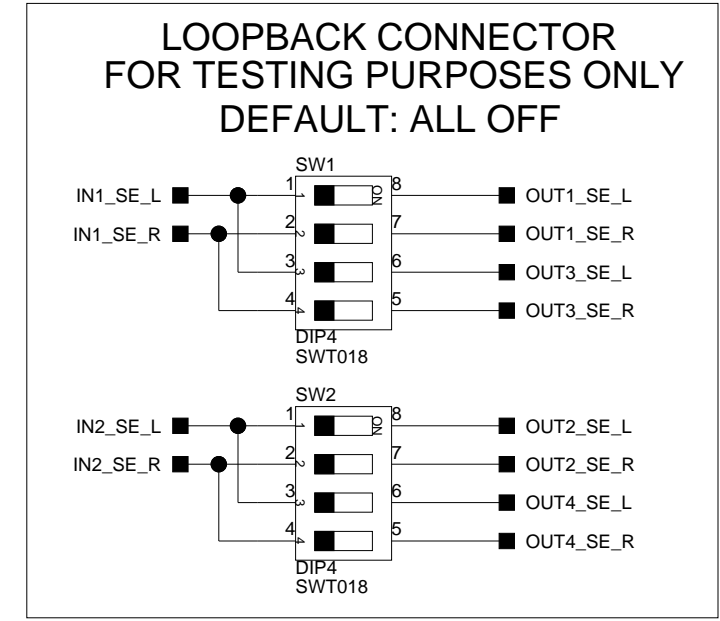

|                               |                                |  |  |
|-------------------------------|--------------------------------|--|--|
|                               |                                | 20 Cotton Road<br>Nashua, NH 03063<br>PH: 1-800-ANALOGD                        |  |
|                               |                                | <b>Title</b> SHARC AUDIO EZ-EXTENDER<br>AD1939 CODEC A (MASTER) - AUDIO PAGE 1 |  |
| <b>Size</b><br>C              | <b>Board No.</b><br>A0223-2008 | <b>Rev</b><br>0.1  |  |
| <b>Date</b><br>6-9-2009_15:31 | <b>Sheet</b> 3 of 24           |  |  |

# IN1

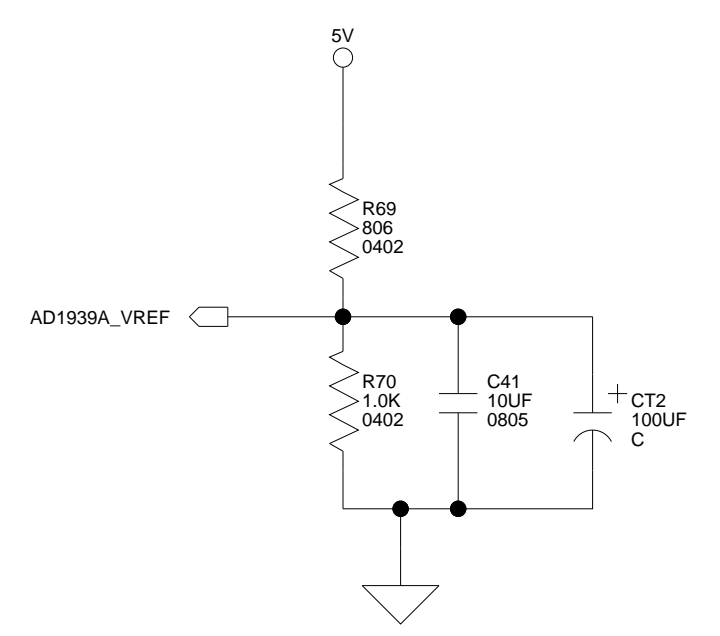
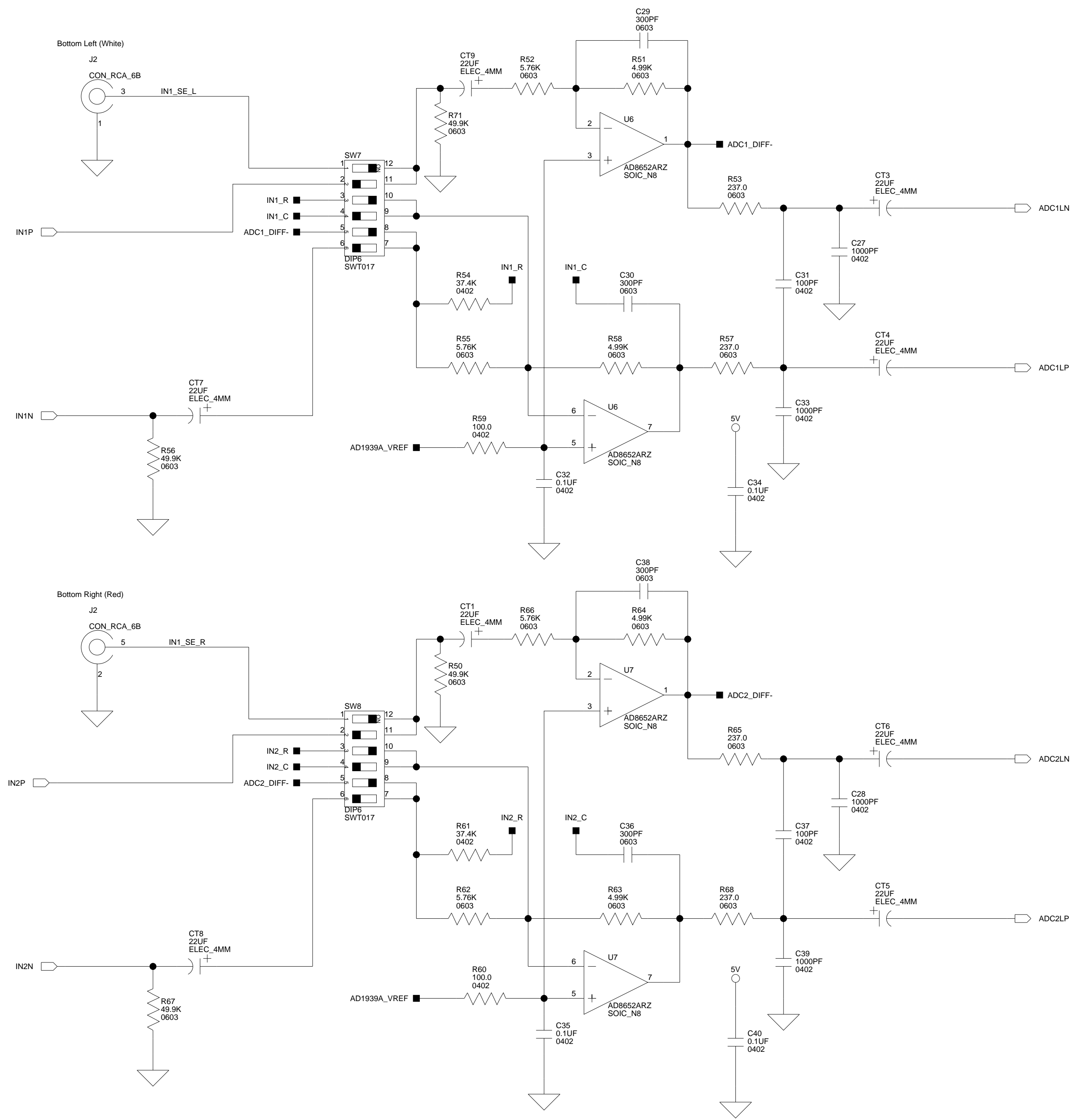

### IN1 (LEFT) SETTINGS

| SWITCH | SINGLE ENDED USE | DIFFERENTIAL USE |
|--------|------------------|------------------|
|        | RCA IN (DEFAULT) | DB25 IN (P1)     |
| SW7.1  | ON               | OFF              |
| SW7.2  | OFF              | ON               |
| SW7.3  | ON               | OFF              |
| SW7.4  | OFF              | ON               |
| SW7.5  | ON               | OFF              |
| SW7.6  | OFF              | ON               |

NOTE: DIFFERENTIAL USE REQUIRES A DB25 TO XLR CABLE.

### IN1 (RIGHT) SETTINGS

| SWITCH | SINGLE ENDED USE | DIFFERENTIAL USE |
|--------|------------------|------------------|
|        | RCA IN (DEFAULT) | DB25 IN (P1)     |
| SW8.1  | ON               | OFF              |
| SW8.2  | OFF              | ON               |
| SW8.3  | ON               | OFF              |
| SW8.4  | OFF              | ON               |
| SW8.5  | ON               | OFF              |
| SW8.6  | OFF              | ON               |

NOTE: DIFFERENTIAL USE REQUIRES A DB25 TO XLR CABLE.

**ANALOG DEVICES**

20 Cotton Road  
Nashua, NH 03063  
PH: 1-800-ANALOGD

|       |                |       |  |     |  |
|-------|----------------|-------|--|-----|--|
| Title |                |       | <b>SHARC AUDIO EZ-EXTENDER<br/>IN1 VIA AD1939A</b> |     |  |
| Size  | Board No.      |       |  | Rev |  |
| C     | A0223-2008     |       |  | 0.1 |  |
| Date  | 6-9-2009_15:31 | Sheet | 4 of   | 24  |  |

# IN2

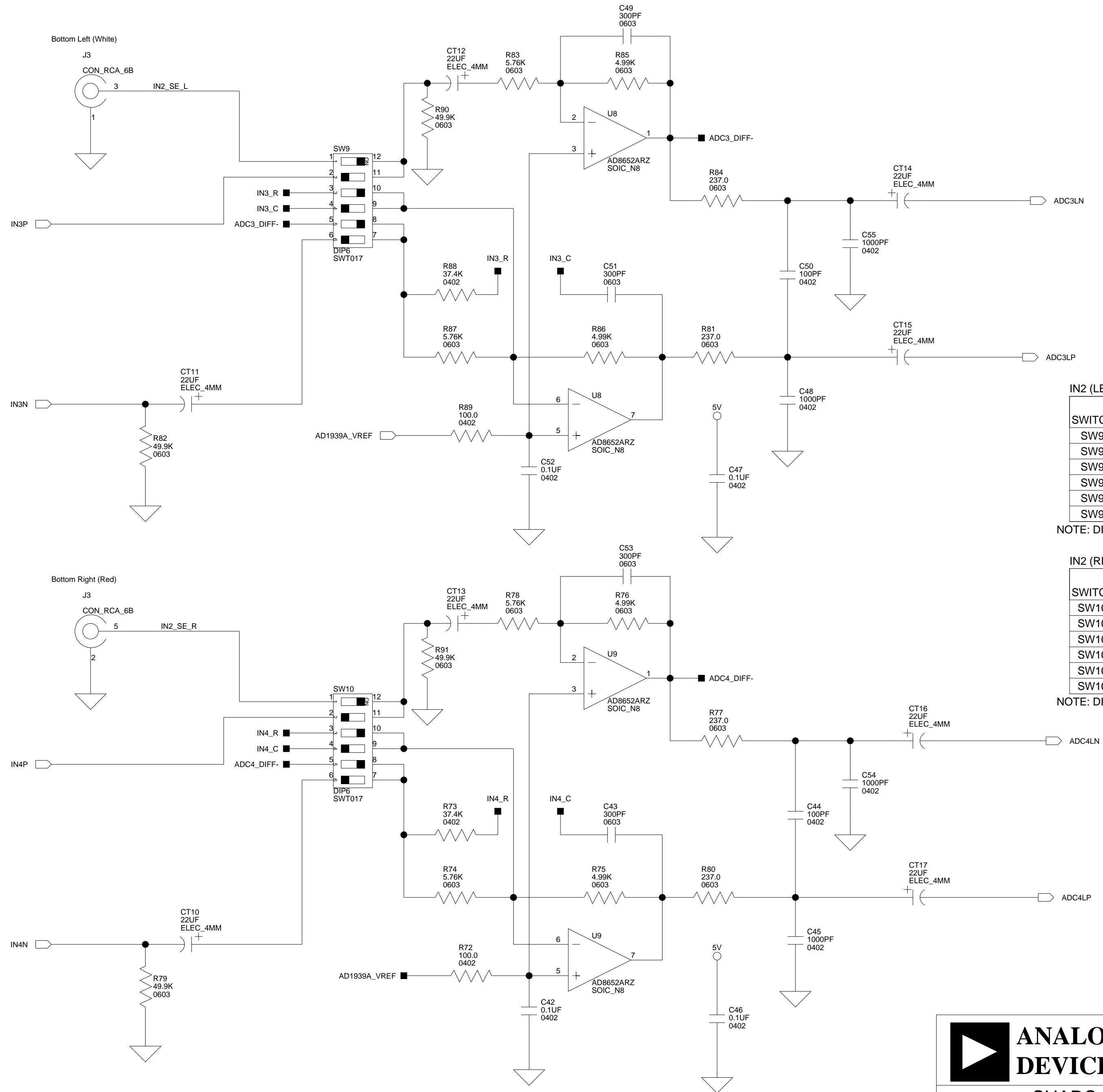

### IN2 (LEFT) SETTINGS

| SWITCH | SINGLE ENDED USE<br>RCA IN (DEFAULT) | DIFFERENTIAL USE<br>DB25 IN (P1) |
|--------|--------------------------------------|----------------------------------|
| SW9.1  | ON                                   | OFF                              |
| SW9.2  | OFF                                  | ON                               |
| SW9.3  | ON                                   | OFF                              |
| SW9.4  | OFF                                  | ON                               |
| SW9.5  | ON                                   | OFF                              |
| SW9.6  | OFF                                  | ON                               |

NOTE: DIFFERENTIAL USE REQUIRES A DB25 TO XLR CABLE.

### IN2 (RIGHT) SETTINGS

| SWITCH | SINGLE ENDED USE<br>RCA IN (DEFAULT) | DIFFERENTIAL USE<br>DB25 IN (P1) |
|--------|--------------------------------------|----------------------------------|
| SW10.1 | ON                                   | OFF                              |
| SW10.2 | OFF                                  | ON                               |
| SW10.3 | ON                                   | OFF                              |
| SW10.4 | OFF                                  | ON                               |
| SW10.5 | ON                                   | OFF                              |
| SW10.6 | OFF                                  | ON                               |

NOTE: DIFFERENTIAL USE REQUIRES A DB25 TO XLR CABLE.

**ANALOG DEVICES**

20 Cotton Road  
Nashua, NH 03063  
PH: 1-800-ANALOGD

|   |                             |                |
|---|-----------------------------|----------------|
| <b>Title</b> SHARC AUDIO EZ-EXTENDER<br>IN2 VIA AD1939A |                             |                |
| <b>Size C</b>   | <b>Board No.</b> A0223-2008 | <b>Rev</b> 0.1 |
| <b>Date</b> 6-9-2009_15:31                              | <b>Sheet</b> 5 <b>of</b> 24 |                |

# OUT1

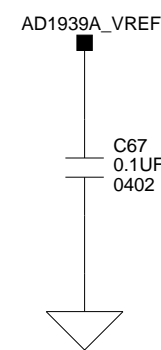
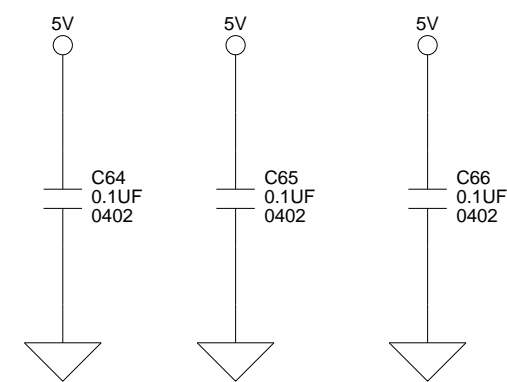
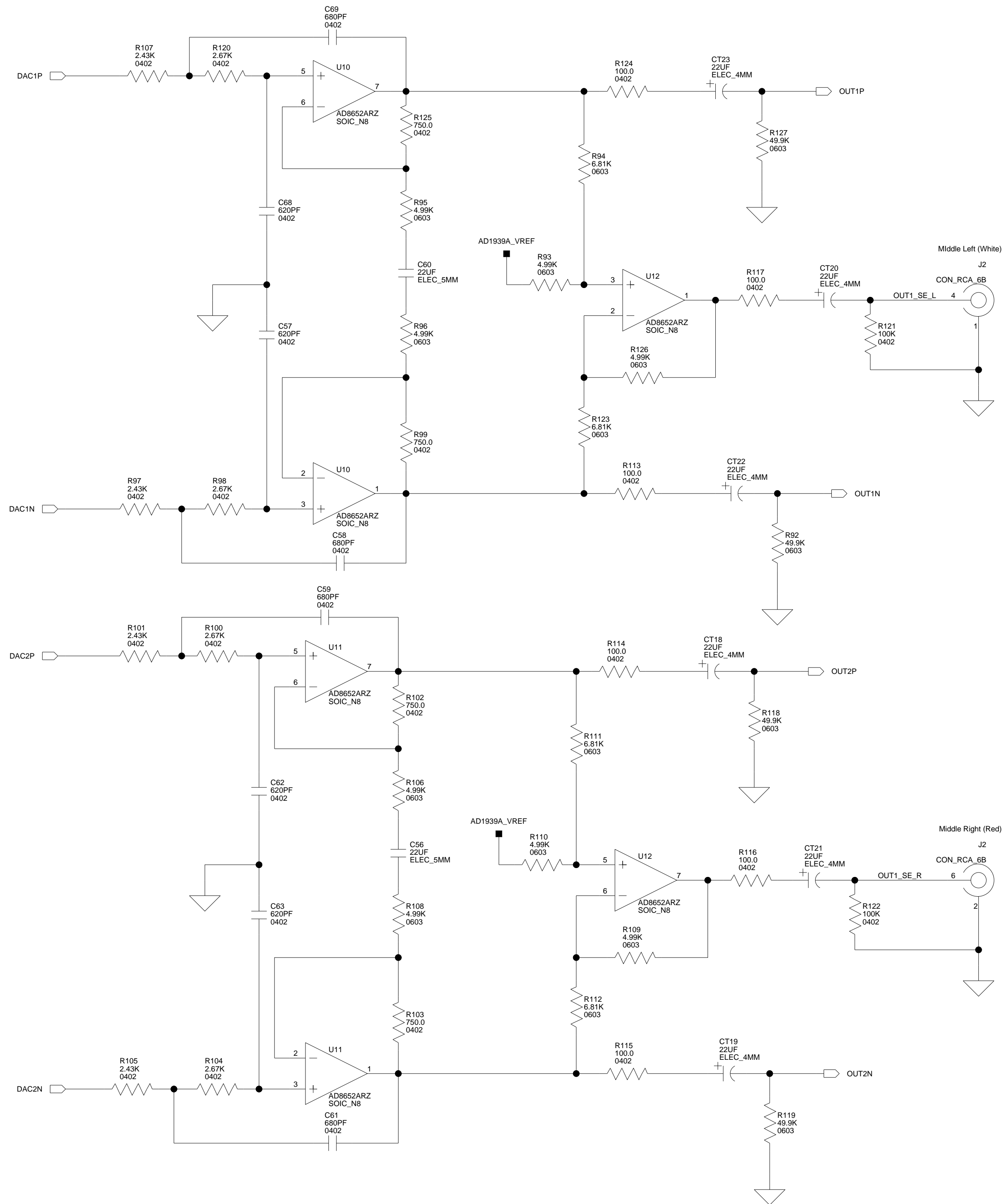

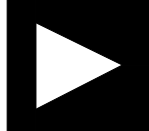
|   |                             |  |  |
|---|-----------------------------|--|--|
|  <b>ANALOG DEVICES</b> |                             | 20 Cotton Road<br>Nashua, NH 03063<br>PH: 1-800-ANALOGD  |  |
|   |                             | <b>Title</b> SHARC AUDIO EZ-EXTENDER<br>OUT1 VIA AD1939A |  |
| <b>Size C</b>   | <b>Board No.</b> A0223-2008 | <b>Rev</b> 0.1   |  |
| <b>Date</b> 6-9-2009_15:31  | <b>Sheet</b> 6 of 24        |  |  |

# OUT2

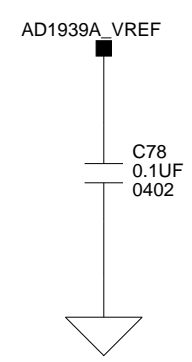
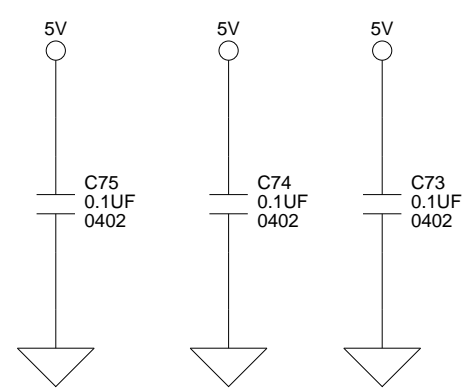
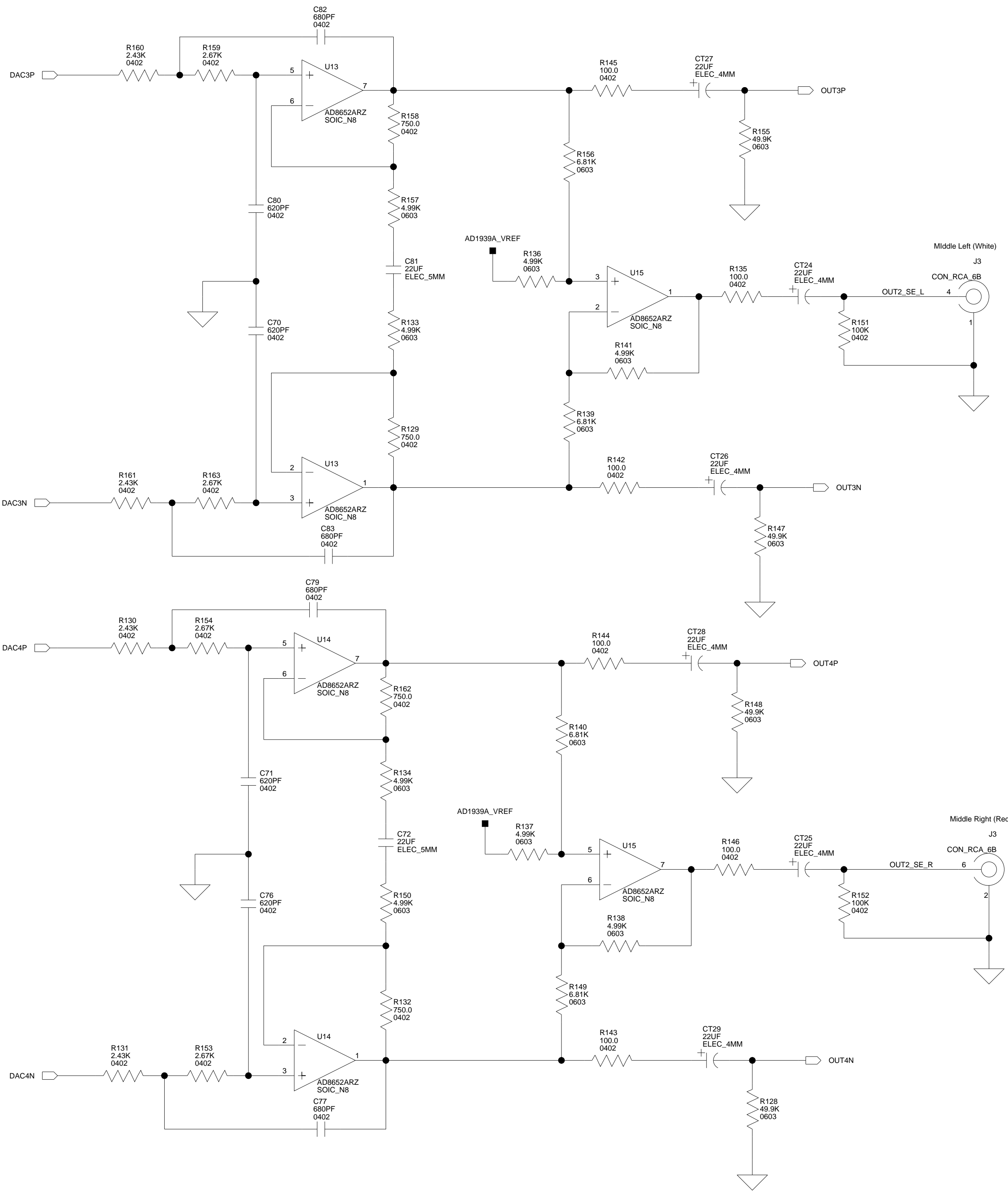

|                            |                             |  |  |
|----------------------------|-----------------------------|--|--|
|                            |                             | 20 Cotton Road<br>Nashua, NH 03063<br>PH: 1-800-ANALOGD  |  |
|                            |                             | <b>Title</b> SHARC AUDIO EZ-EXTENDER<br>OUT2 VIA AD1939A |  |
| <b>Size C</b>              | <b>Board No.</b> A0223-2008 | <b>Rev</b> 0.1   |  |
| <b>Date</b> 6-9-2009_15:31 | <b>Sheet</b> 7 of 24        |  |  |

# OUT3

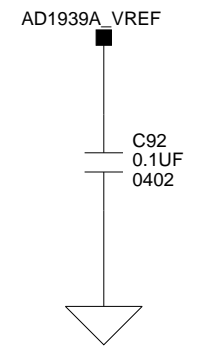
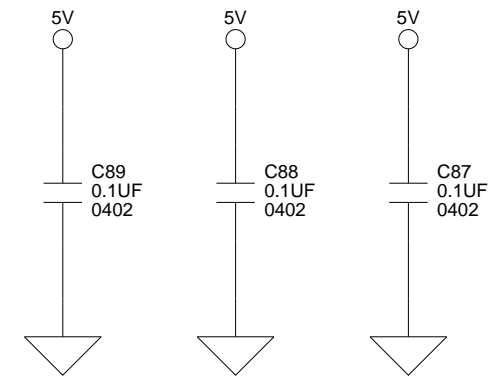
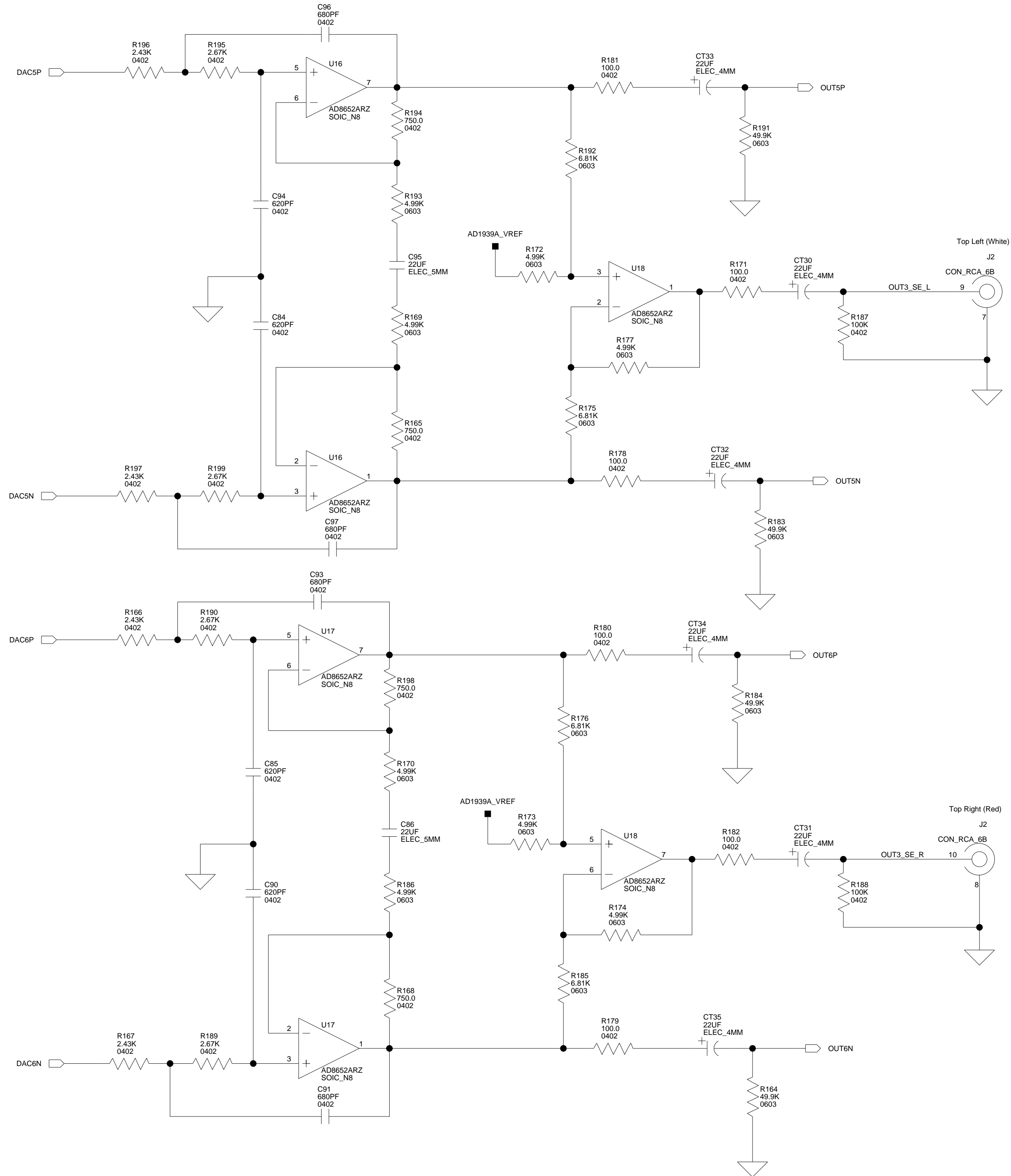

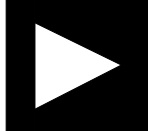
|   |                             |  |  |
|---|-----------------------------|--|--|
|  <b>ANALOG DEVICES</b> |                             | 20 Cotton Road<br>Nashua, NH 03063<br>PH: 1-800-ANALOGD  |  |
|   |                             | <b>Title</b> SHARC AUDIO EZ-EXTENDER<br>OUT3 VIA AD1939A |  |
| <b>Size C</b>   | <b>Board No.</b> A0223-2008 | <b>Rev</b> 0.1   |  |
| <b>Date</b> 6-9-2009_15:31  | <b>Sheet</b> 8 of 24        |  |  |

# OUT4

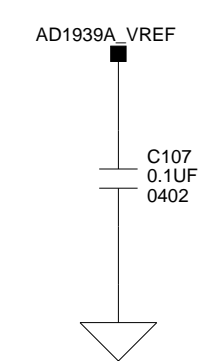
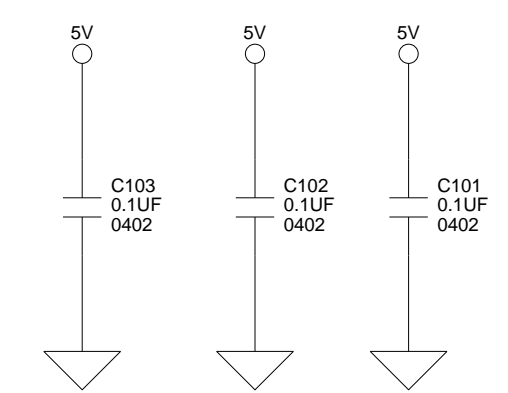
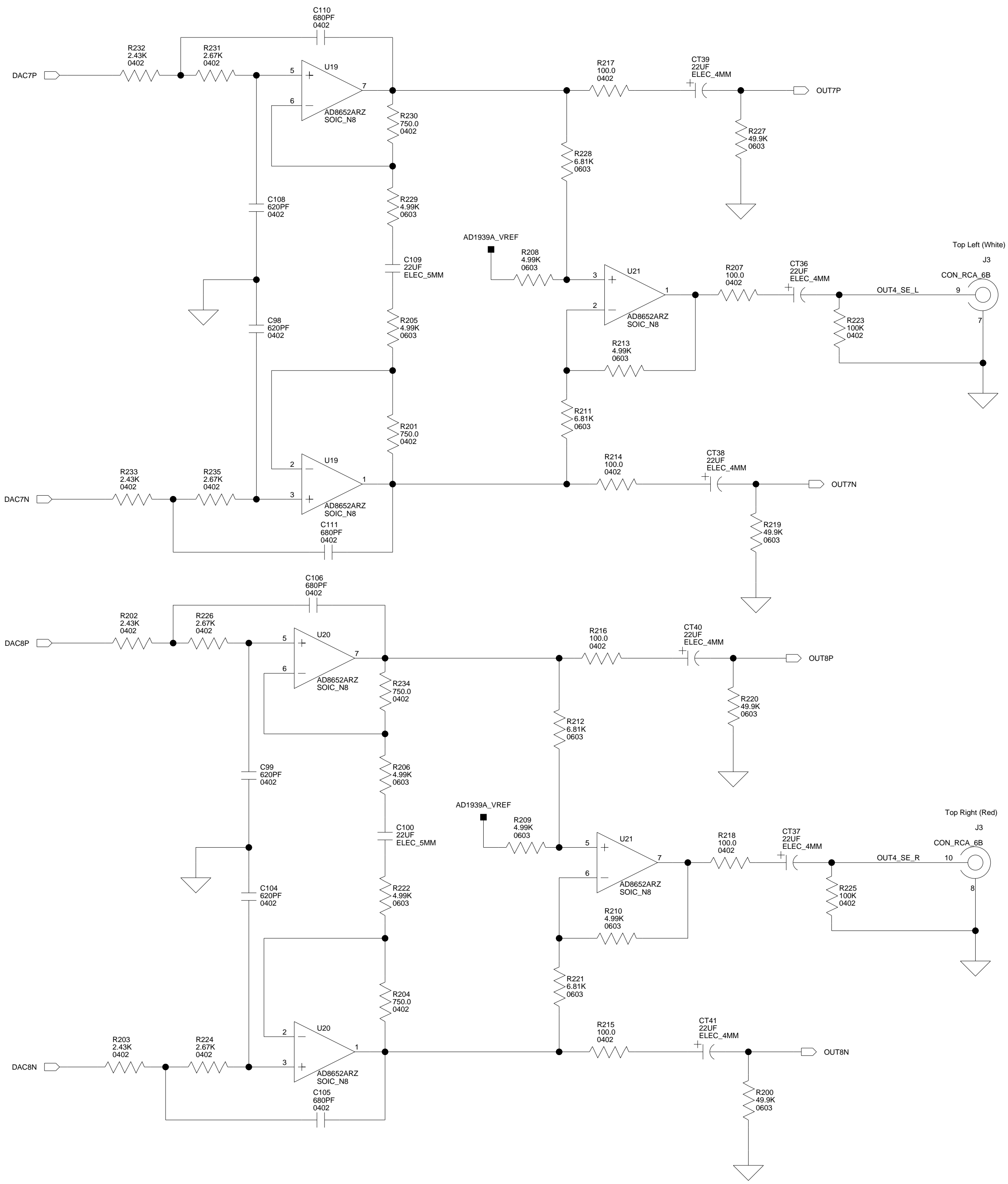

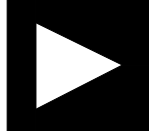
|   |                  |  |            |
|---|------------------|--|------------|
|  <b>ANALOG DEVICES</b> |                  | 20 Cotton Road<br>Nashua, NH 03063<br>PH: 1-800-ANALOGD  |            |
|   |                  | <b>Title</b> SHARC AUDIO EZ-EXTENDER<br>OUT4 VIA AD1939A |            |
| <b>Size C</b>   | <b>Board No.</b> | A0223-2008   | <b>Rev</b> |
| <b>Date</b>   | 6-9-2009_15:31   | <b>Sheet</b>   | 9 of 24    |

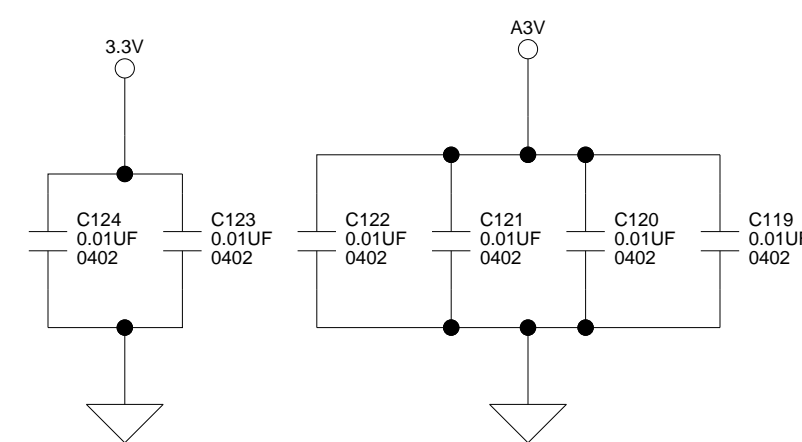
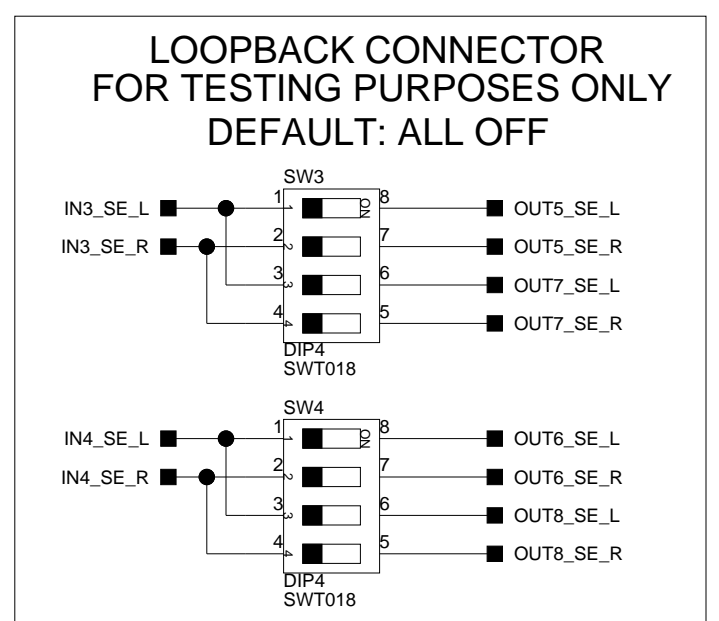
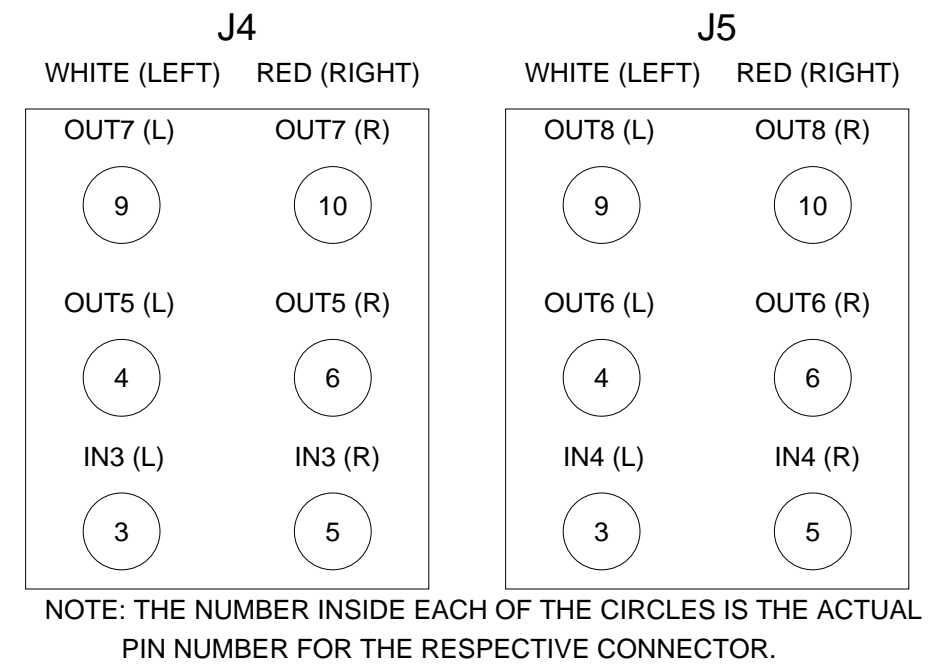
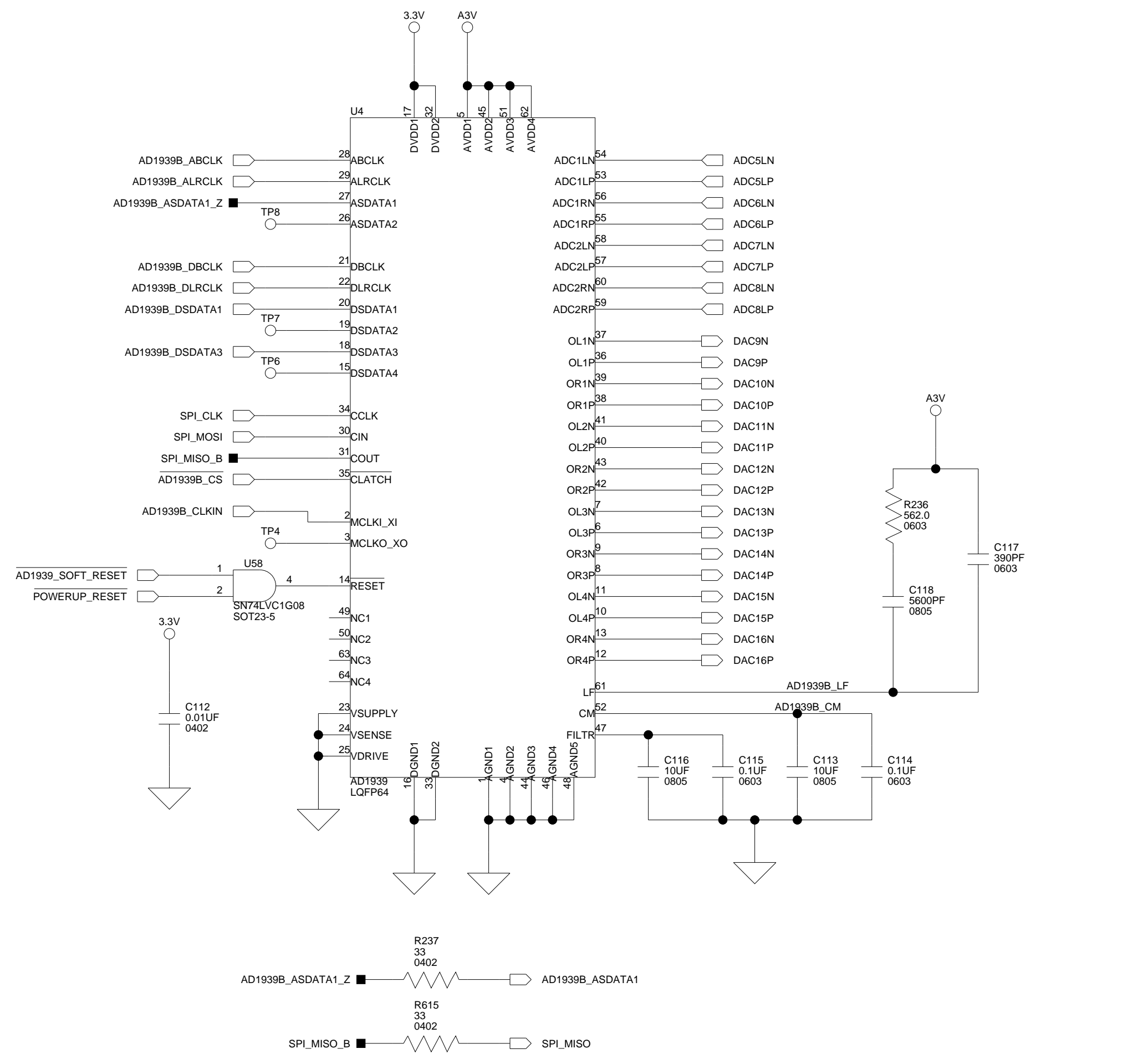

|                            |                             |   |           |
|----------------------------|-----------------------------|---|-----------|
|                            |                             | 20 Cotton Road<br>Nashua, NH 03063<br>PH: 1-800-ANALOGD |           |
|                            |                             | <b>Title</b> SHARC AUDIO EZ-EXTENDER<br>AD1939 CODEC B  |           |
| <b>Size C</b>              | <b>Board No.</b> A0223-2008 | <b>Rev</b> 0.1  |           |
| <b>Date</b> 6-9-2009_15:31 | <b>Sheet</b> 10 of          |   | <b>24</b> |



# IN3

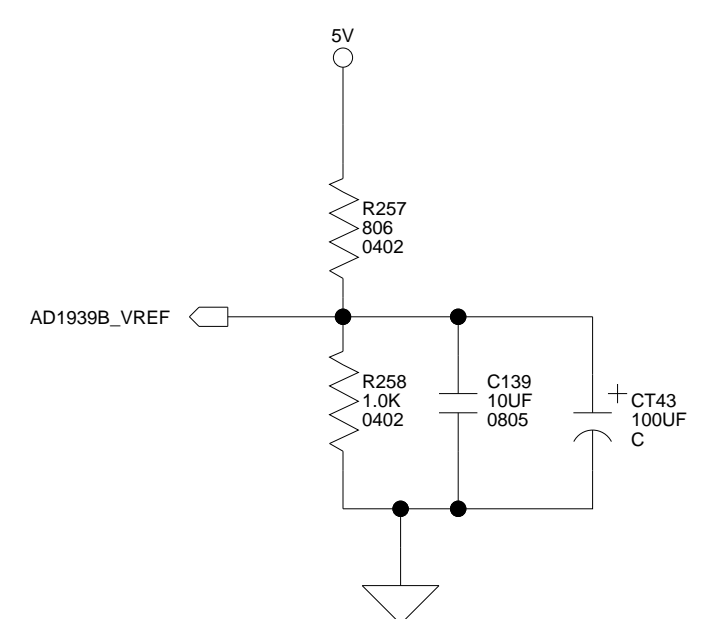
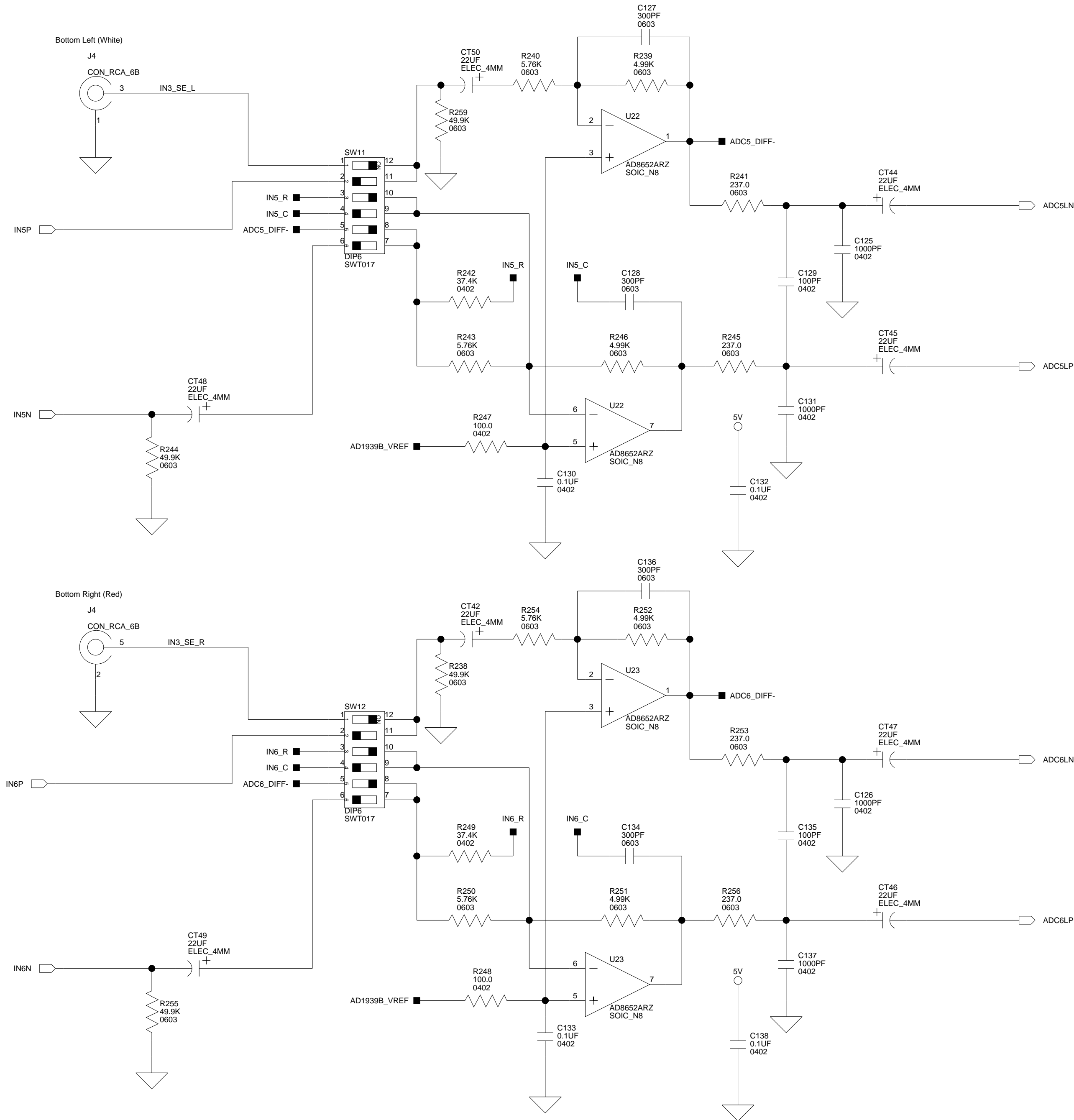

### IN3 (LEFT) SETTINGS

| SWITCH | SINGLE ENDED USE | DIFFERENTIAL USE |
|--------|------------------|------------------|
|        | RCA IN (DEFAULT) | DB25 IN (P1)     |
| SW11.1 | ON               | OFF              |
| SW11.2 | OFF              | ON               |
| SW11.3 | ON               | OFF              |
| SW11.4 | OFF              | ON               |
| SW11.5 | ON               | OFF              |
| SW11.6 | OFF              | ON               |

NOTE: DIFFERENTIAL USE REQUIRES A DB25 TO XLR CABLE.

### IN3 (RIGHT) SETTINGS

| SWITCH | SINGLE ENDED USE | DIFFERENTIAL USE |
|--------|------------------|------------------|
|        | RCA IN (DEFAULT) | DB25 IN (P1)     |
| SW12.1 | ON               | OFF              |
| SW12.2 | OFF              | ON               |
| SW12.3 | ON               | OFF              |
| SW12.4 | OFF              | ON               |
| SW12.5 | ON               | OFF              |
| SW12.6 | OFF              | ON               |

NOTE: DIFFERENTIAL USE REQUIRES A DB25 TO XLR CABLE.

**ANALOG DEVICES**

20 Cotton Road  
Nashua, NH 03063  
PH: 1-800-ANALOGD

|   |                              |                |
|---|------------------------------|----------------|
| <b>Title</b> SHARC AUDIO EZ-EXTENDER<br>IN3 VIA AD1939B |                              |                |
| <b>Size C</b>   | <b>Board No.</b> A0223-2008  | <b>Rev</b> 0.1 |
| <b>Date</b> 6-9-2009_15:31                              | <b>Sheet</b> 11 <b>of</b> 24 |                |

# IN4

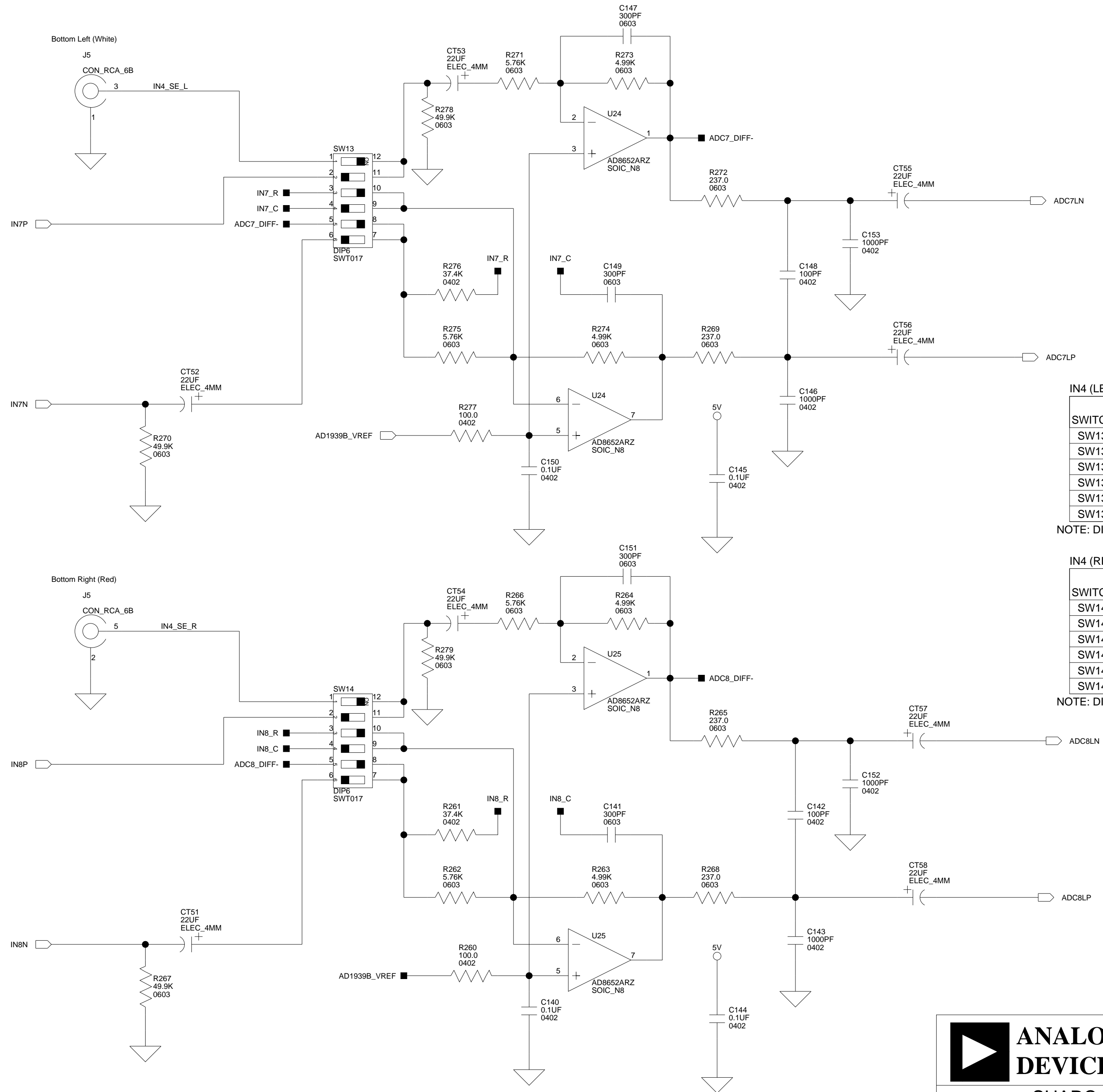

### IN4 (LEFT) SETTINGS

| SWITCH | SINGLE ENDED USE<br>RCA IN (DEFAULT) | DIFFERENTIAL USE<br>DB25 IN (P1) |
|--------|--------------------------------------|----------------------------------|
| SW13.1 | ON                                   | OFF                              |
| SW13.2 | OFF                                  | ON                               |
| SW13.3 | ON                                   | OFF                              |
| SW13.4 | OFF                                  | ON                               |
| SW13.5 | ON                                   | OFF                              |
| SW13.6 | OFF                                  | ON                               |

NOTE: DIFFERENTIAL USE REQUIRES A DB25 TO XLR CABLE.

### IN4 (RIGHT) SETTINGS

| SWITCH | SINGLE ENDED USE<br>RCA IN (DEFAULT) | DIFFERENTIAL USE<br>DB25 IN (P1) |
|--------|--------------------------------------|----------------------------------|
| SW14.1 | ON                                   | OFF                              |
| SW14.2 | OFF                                  | ON                               |
| SW14.3 | ON                                   | OFF                              |
| SW14.4 | OFF                                  | ON                               |
| SW14.5 | ON                                   | OFF                              |
| SW14.6 | OFF                                  | ON                               |

NOTE: DIFFERENTIAL USE REQUIRES A DB25 TO XLR CABLE.

**ANALOG DEVICES**

20 Cotton Road  
Nashua, NH 03063  
PH: 1-800-ANALOGD

|        |                |            |  |    |     |
|--------|----------------|------------|--|----|-----|
| Title  |                |            | <b>SHARC AUDIO EZ-EXTENDER<br/>IN4 VIA AD1939B</b> |    |     |
| Size C | Board No.      | A0223-2008 |  |    | Rev |
| Date   | 6-9-2009_15:31 | Sheet      | 12 of  | 24 |     |

# OUT5

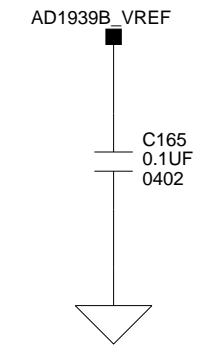
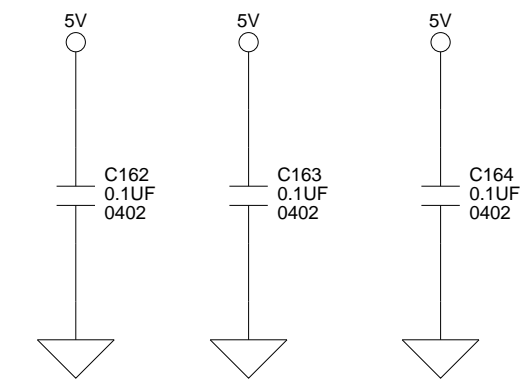
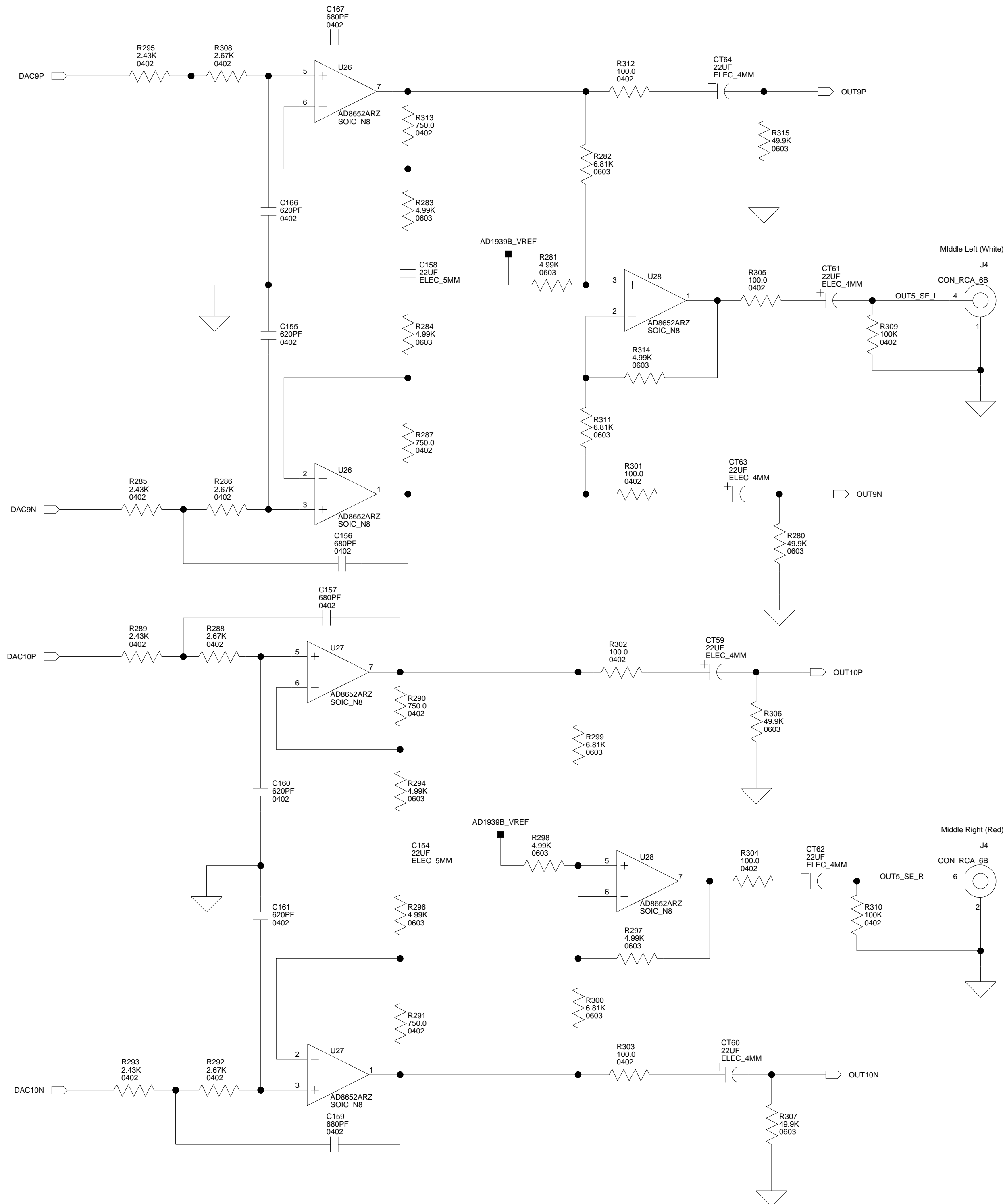

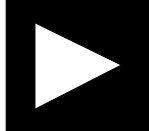
|   |                  |  |            |
|---|------------------|--|------------|
|  <b>ANALOG DEVICES</b> |                  | 20 Cotton Road<br>Nashua, NH 03063<br>PH: 1-800-ANALOGD  |            |
|   |                  | <b>Title</b> SHARC AUDIO EZ-EXTENDER<br>OUT5 VIA AD1939B |            |
| <b>Size C</b>   | <b>Board No.</b> | A0223-2008   | <b>Rev</b> |
| <b>Date</b>   | 6-9-2009_15:31   | <b>Sheet</b>   | 13 of 24   |

# OUT6

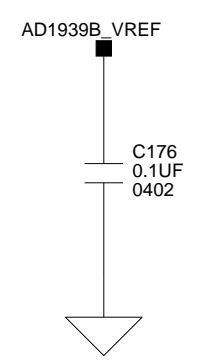
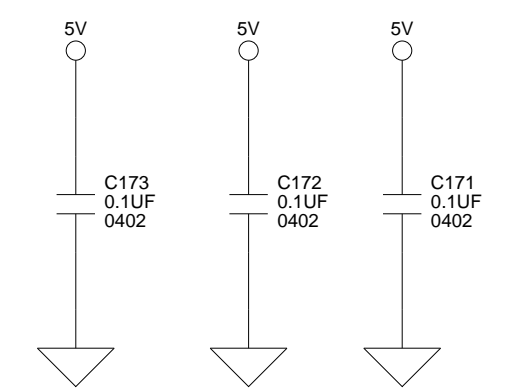
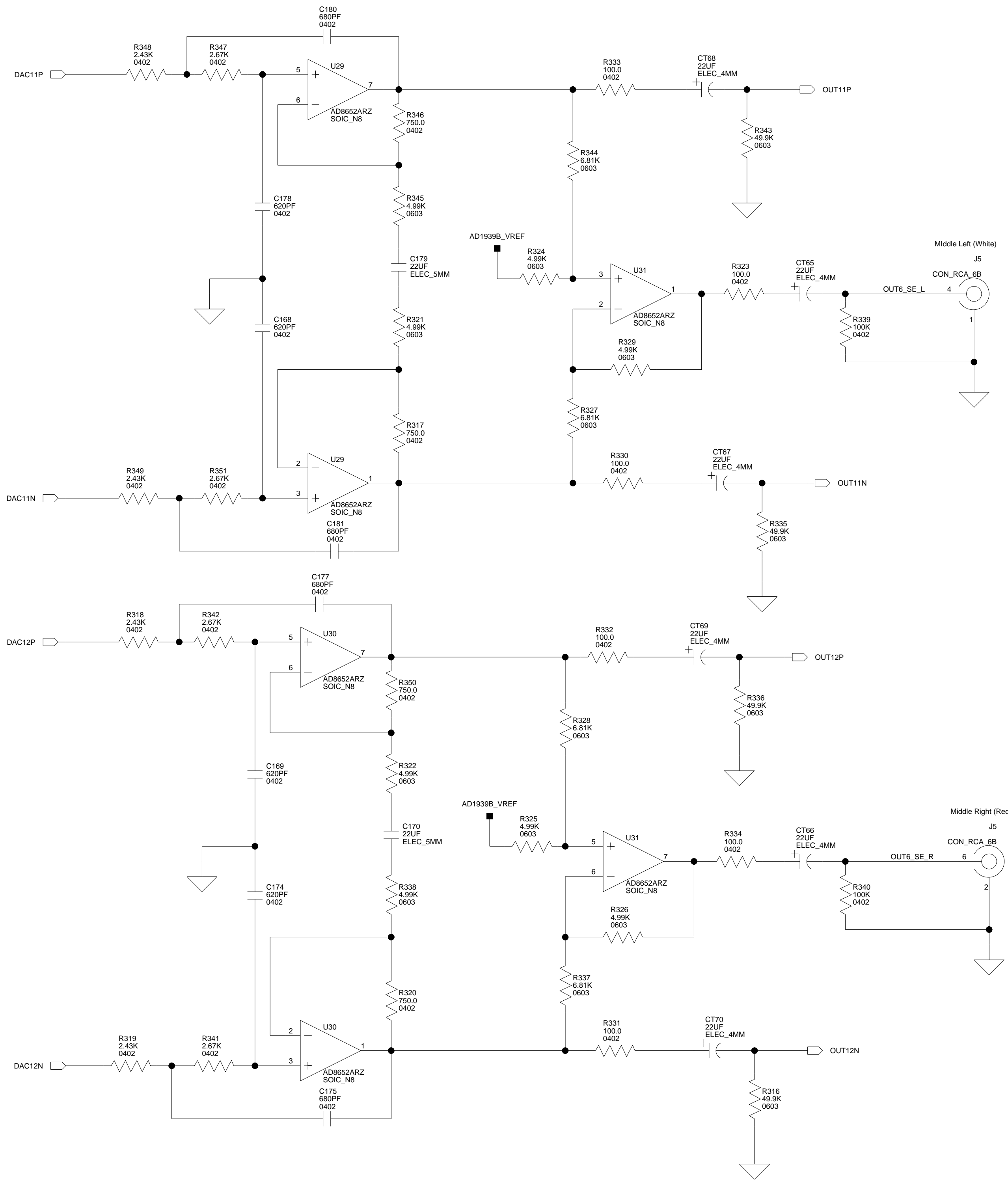

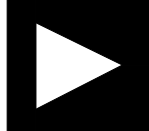
|   |                             |  |  |
|---|-----------------------------|--|--|
|  <b>ANALOG DEVICES</b> |                             | 20 Cotton Road<br>Nashua, NH 03063<br>PH: 1-800-ANALOGD  |  |
|   |                             | <b>Title</b> SHARC AUDIO EZ-EXTENDER<br>OUT6 VIA AD1939B |  |
| <b>Size C</b>   | <b>Board No.</b> A0223-2008 | <b>Rev</b> 0.1   |  |
| <b>Date</b> 6-9-2009_15:31  | <b>Sheet</b> 14 of 24       |  |  |

# OUT7

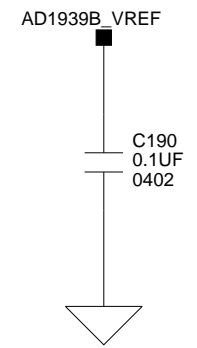
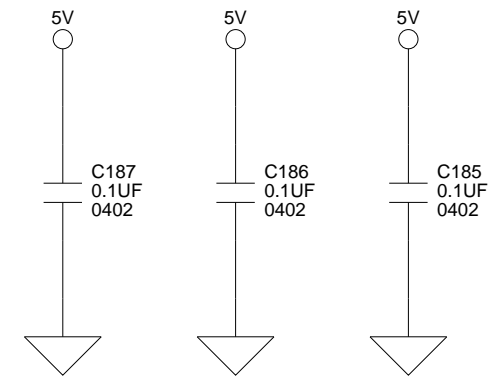
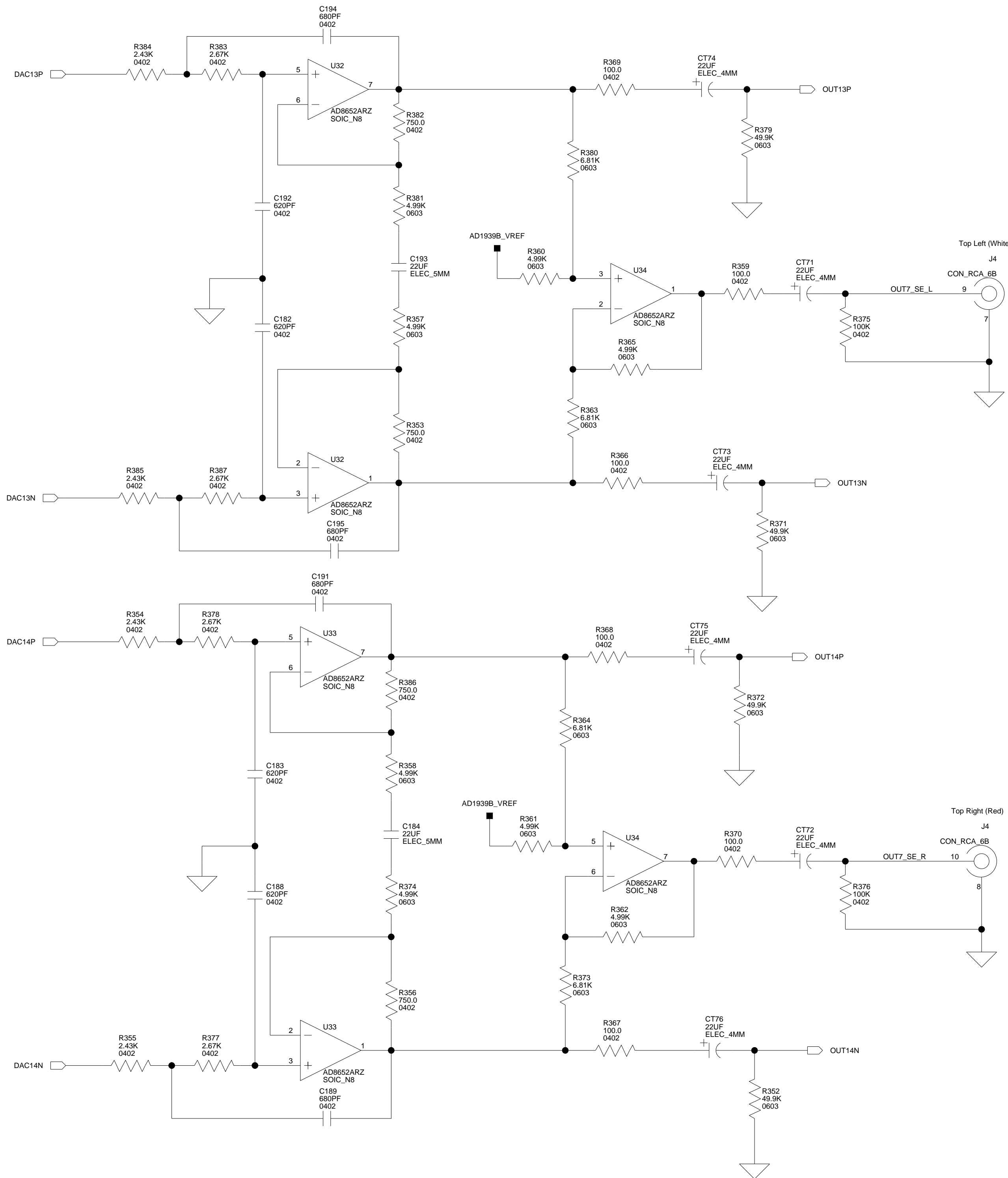

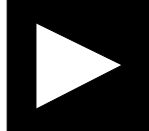
|   |                  |  |            |
|---|------------------|--|------------|
|  <b>ANALOG DEVICES</b> |                  | 20 Cotton Road<br>Nashua, NH 03063<br>PH: 1-800-ANALOGD  |            |
|   |                  | <b>Title</b> SHARC AUDIO EZ-EXTENDER<br>OUT7 VIA AD1939B |            |
| <b>Size C</b>   | <b>Board No.</b> | A0223-2008   | <b>Rev</b> |
| <b>Date</b>   | 6-9-2009_15:31   | <b>Sheet</b>   | 15 of 24   |

# OUT8

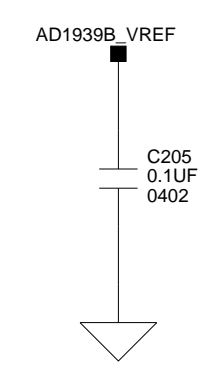
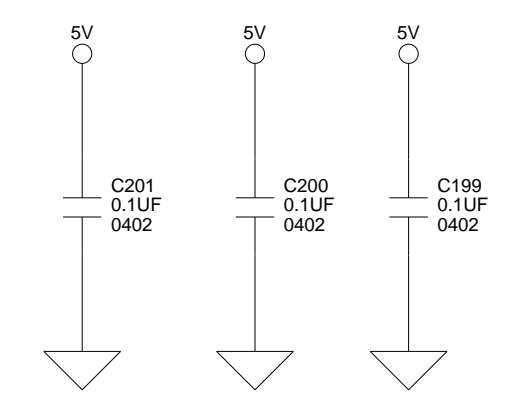
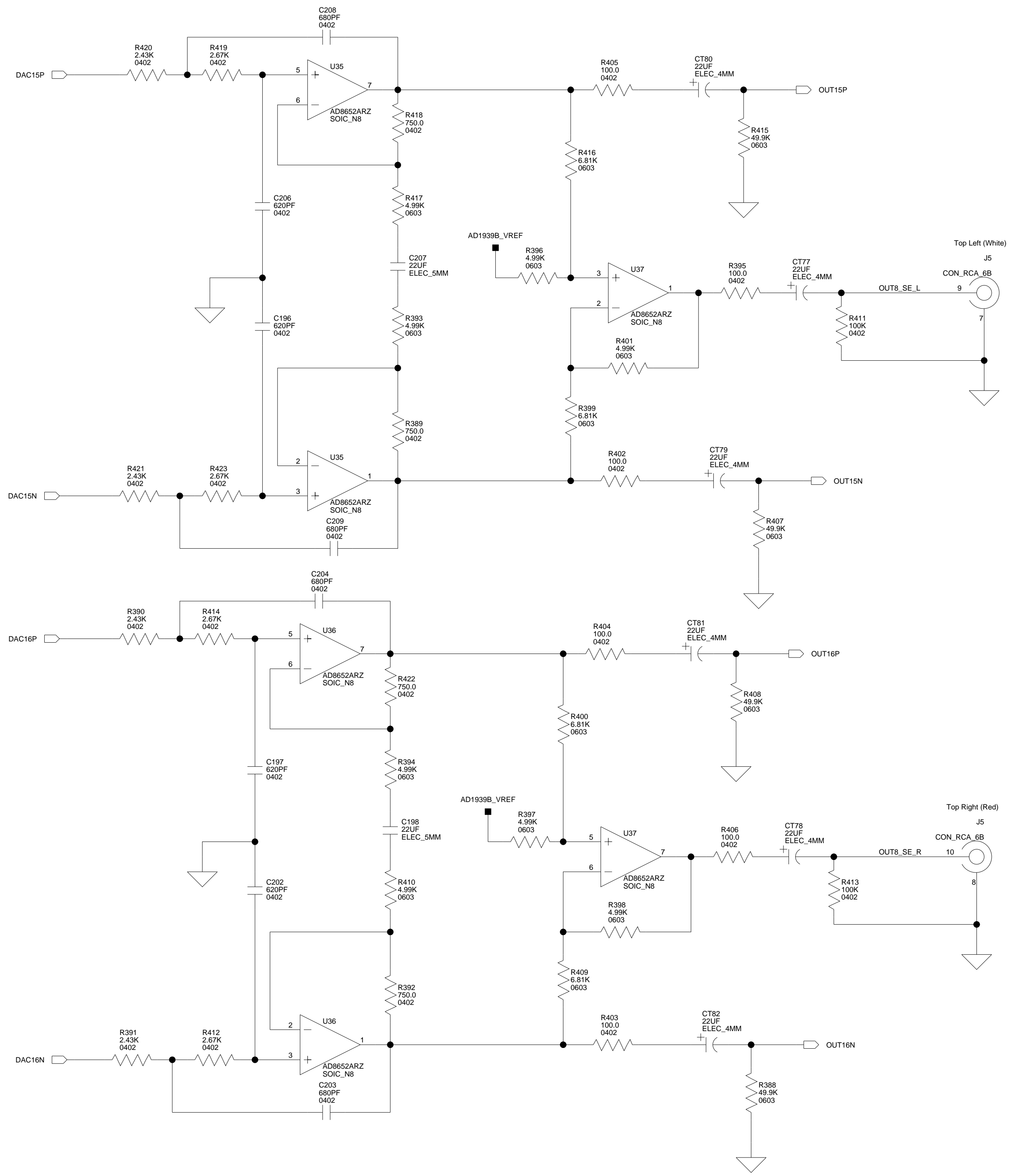

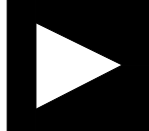
|   |                             |   |
|---|-----------------------------|---|
|  <b>ANALOG DEVICES</b> |                             | 20 Cotton Road<br>Nashua, NH 03063<br>PH: 1-800-ANALOGD |
| <b>Title</b> SHARC AUDIO EZ-EXTENDER<br>OUT8 VIA AD1939B  |                             |   |
| <b>Size C</b>   | <b>Board No.</b> A0223-2008 | <b>Rev</b> 0.1  |
| <b>Date</b> 6-9-2009_15:31  | <b>Sheet</b> 16 of          | <b>24</b>   |

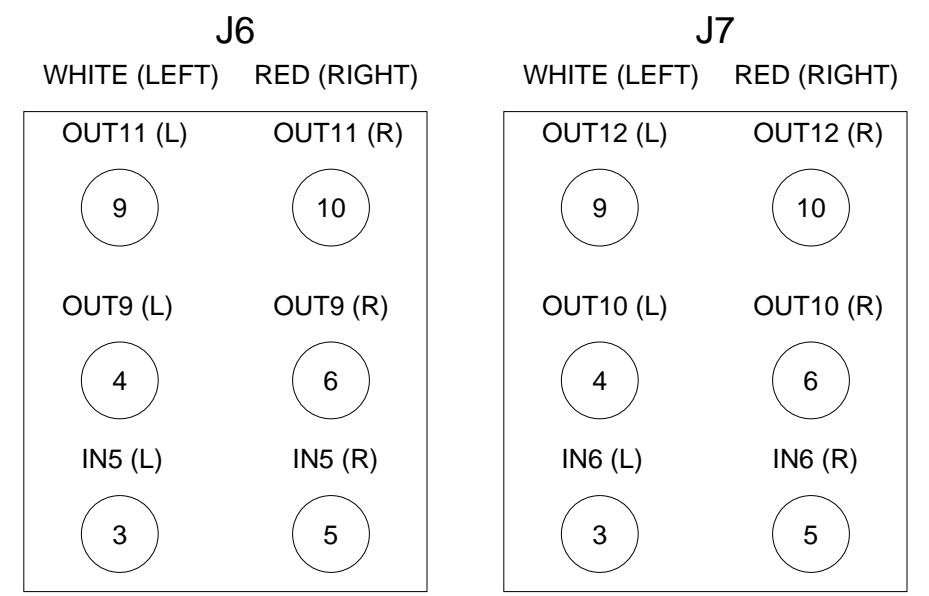
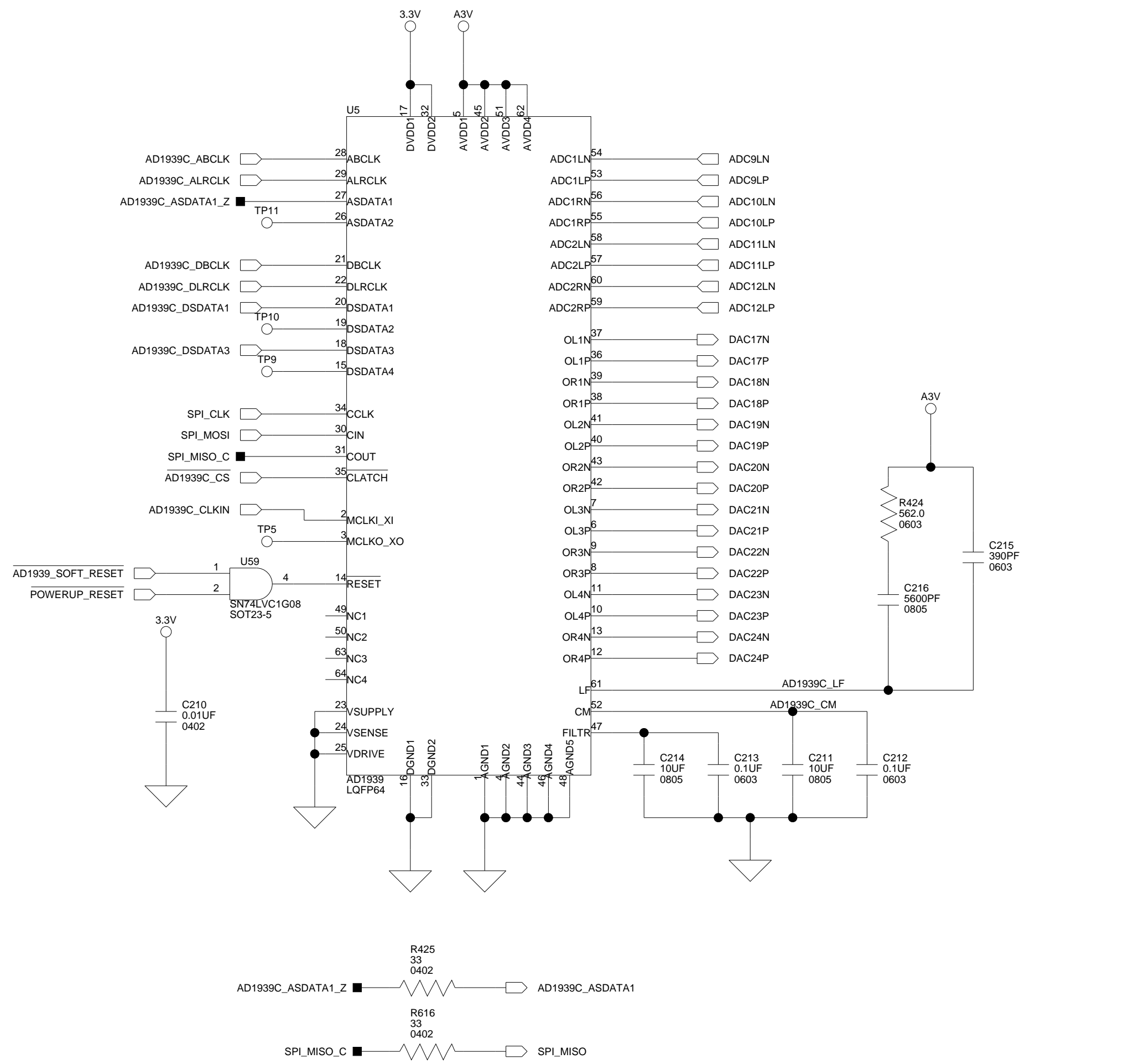

NOTE: THE NUMBER INSIDE EACH OF THE CIRCLES IS THE ACTUAL PIN NUMBER FOR THE RESPECTIVE CONNECTOR.

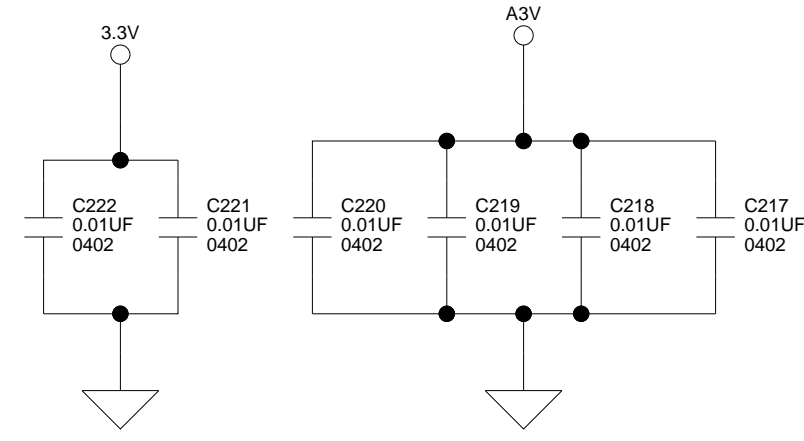
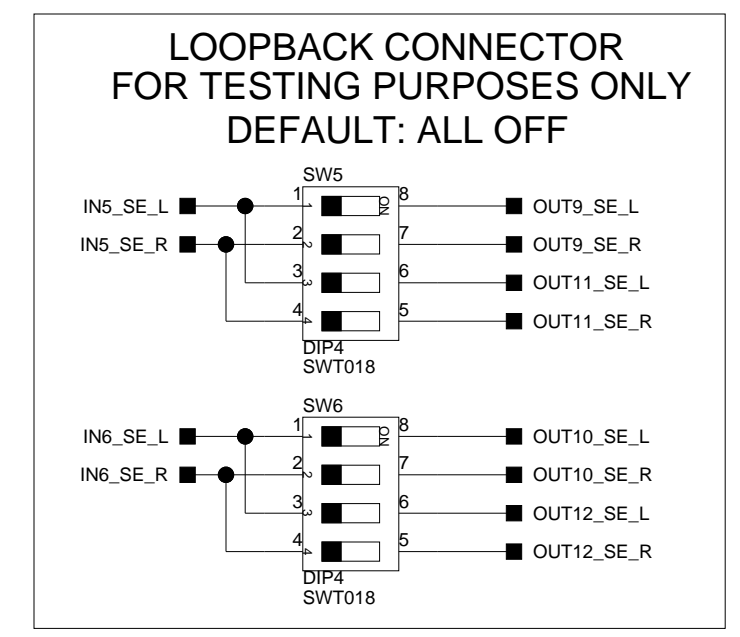

|                            |                             |   |           |
|----------------------------|-----------------------------|---|-----------|
|                            |                             | 20 Cotton Road<br>Nashua, NH 03063<br>PH: 1-800-ANALOGD |           |
|                            |                             | <b>Title</b> SHARC AUDIO EZ-EXTENDER<br>AD1939 CODEC C  |           |
| <b>Size C</b>              | <b>Board No.</b> A0223-2008 | <b>Rev</b> 0.1  |           |
| <b>Date</b> 6-9-2009_15:31 | <b>Sheet</b> 17 of          |   | <b>24</b> |

# IN5

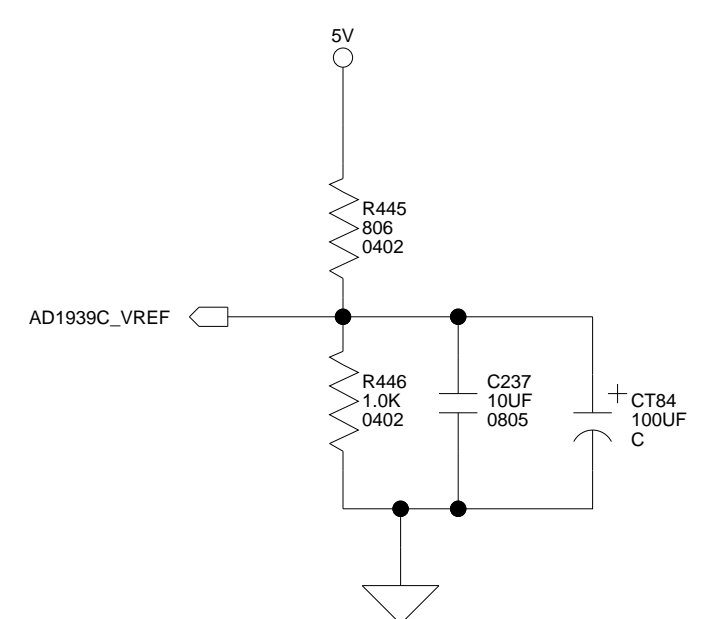
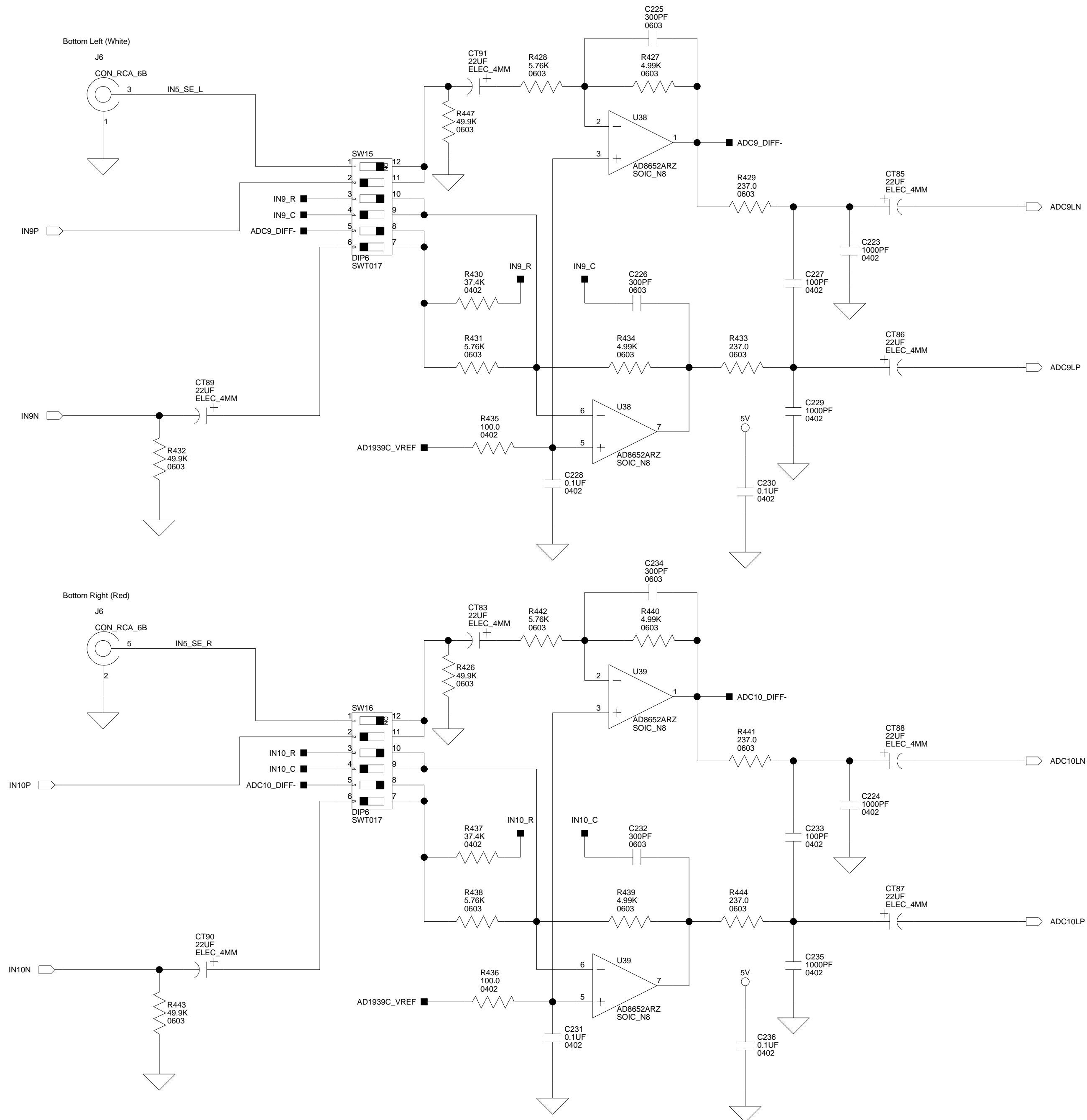

### IN5 (LEFT) SETTINGS

| SWITCH | SINGLE ENDED USE | DIFFERENTIAL USE |
|--------|------------------|------------------|
|        | RCA IN (DEFAULT) | DB25 IN (P2)     |
| SW15.1 | ON               | OFF              |
| SW15.2 | OFF              | ON               |
| SW15.3 | ON               | OFF              |
| SW15.4 | OFF              | ON               |
| SW15.5 | ON               | OFF              |
| SW15.6 | OFF              | ON               |

NOTE: DIFFERENTIAL USE REQUIRES A DB25 TO XLR CABLE.

### IN5 (RIGHT) SETTINGS

| SWITCH | SINGLE ENDED USE | DIFFERENTIAL USE |
|--------|------------------|------------------|
|        | RCA IN (DEFAULT) | DB25 IN (P2)     |
| SW16.1 | ON               | OFF              |
| SW16.2 | OFF              | ON               |
| SW16.3 | ON               | OFF              |
| SW16.4 | OFF              | ON               |
| SW16.5 | ON               | OFF              |
| SW16.6 | OFF              | ON               |

NOTE: DIFFERENTIAL USE REQUIRES A DB25 TO XLR CABLE.

**ANALOG DEVICES**

20 Cotton Road  
Nashua, NH 03063  
PH: 1-800-ANALOGD

|                  |                |            |  |    |                   |
|------------------|----------------|------------|--|----|-------------------|
| Title            |                |            | <b>SHARC AUDIO EZ-EXTENDER<br/>IN5 VIA AD1939C</b> |    |                   |
| Size<br><b>C</b> | Board No.      | A0223-2008 |  |    | Rev<br><b>0.1</b> |
| Date             | 6-9-2009_15:31 | Sheet      | 18 of  | 24 |                   |



# IN6

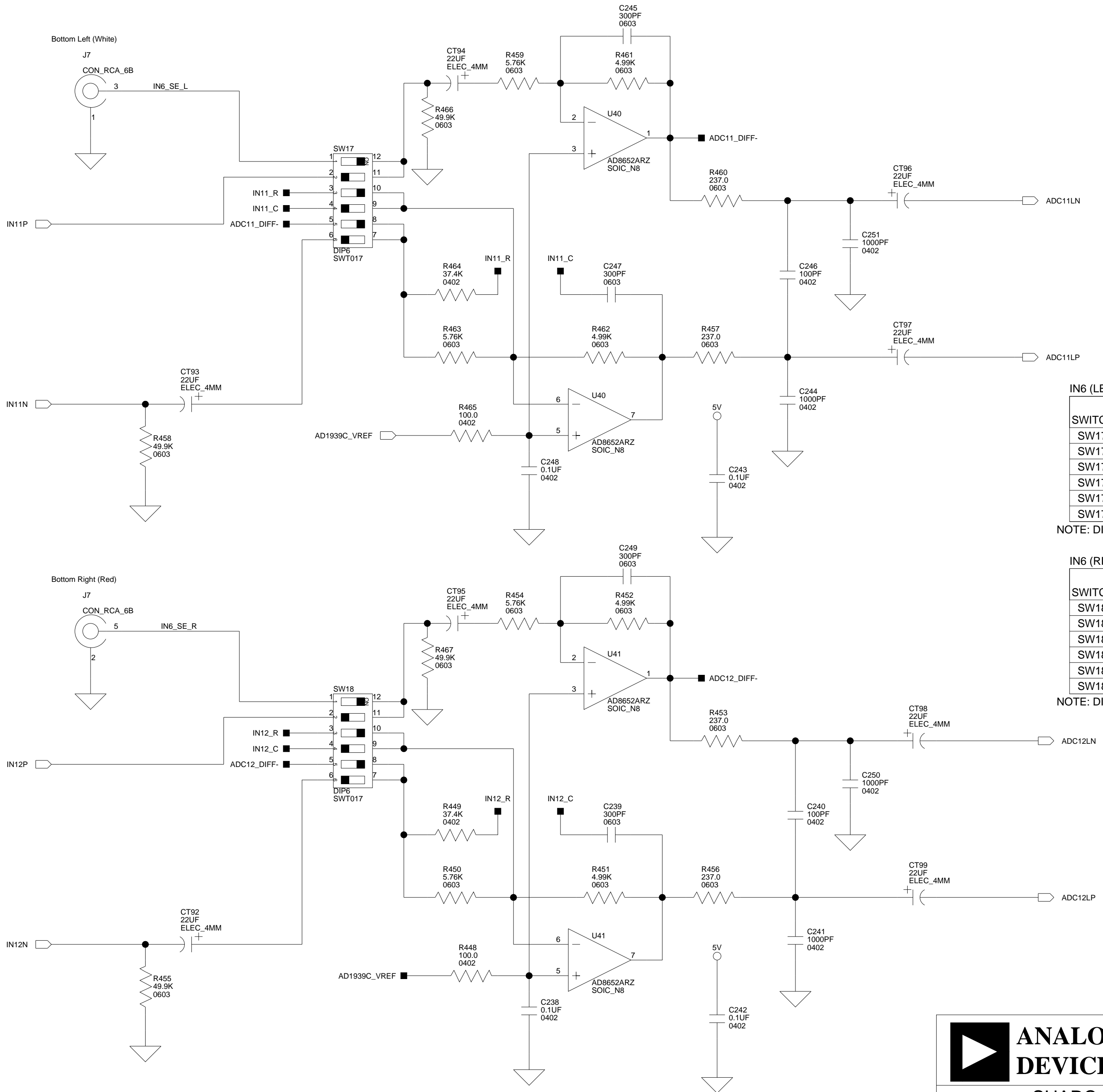

### IN6 (LEFT) SETTINGS

| SWITCH | SINGLE ENDED USE<br>RCA IN (DEFAULT) | DIFFERENTIAL USE<br>DB25 IN (P2) |
|--------|--------------------------------------|----------------------------------|
| SW17.1 | ON                                   | OFF                              |
| SW17.2 | OFF                                  | ON                               |
| SW17.3 | ON                                   | OFF                              |
| SW17.4 | OFF                                  | ON                               |
| SW17.5 | ON                                   | OFF                              |
| SW17.6 | OFF                                  | ON                               |

NOTE: DIFFERENTIAL USE REQUIRES A DB25 TO XLR CABLE.

### IN6 (RIGHT) SETTINGS

| SWITCH | SINGLE ENDED USE<br>RCA IN (DEFAULT) | DIFFERENTIAL USE<br>DB25 IN (P2) |
|--------|--------------------------------------|----------------------------------|
| SW18.1 | ON                                   | OFF                              |
| SW18.2 | OFF                                  | ON                               |
| SW18.3 | ON                                   | OFF                              |
| SW18.4 | OFF                                  | ON                               |
| SW18.5 | ON                                   | OFF                              |
| SW18.6 | OFF                                  | ON                               |

NOTE: DIFFERENTIAL USE REQUIRES A DB25 TO XLR CABLE.

**ANALOG DEVICES**

20 Cotton Road  
Nashua, NH 03063  
PH: 1-800-ANALOGD

---

**Title** SHARC AUDIO EZ-EXTENDER  
IN6 VIA AD1939C

|                            |                             |                |
|----------------------------|-----------------------------|----------------|
| <b>Size C</b>              | <b>Board No.</b> A0223-2008 | <b>Rev</b> 0.1 |
| <b>Date</b> 6-9-2009_15:31 | <b>Sheet</b> 19 of 24       |                |

# OUT9

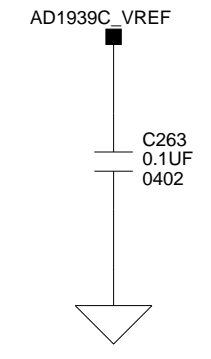
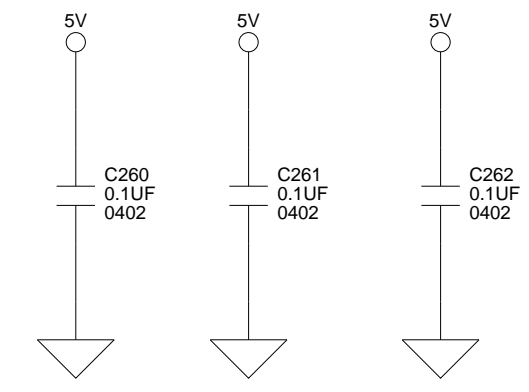
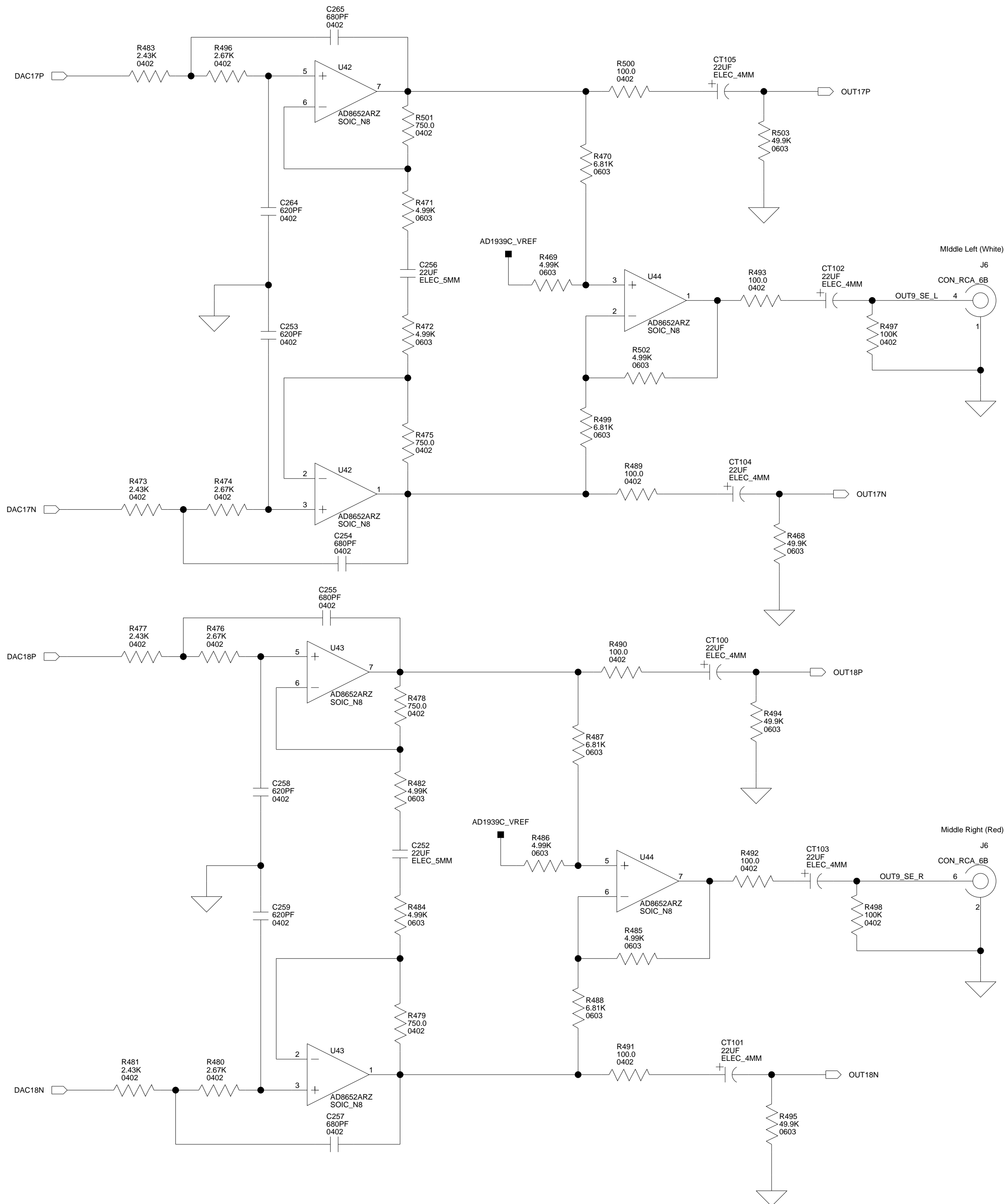

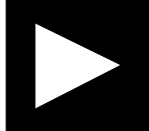
|   |                  |  |            |
|---|------------------|--|------------|
|  <b>ANALOG DEVICES</b> |                  | 20 Cotton Road<br>Nashua, NH 03063<br>PH: 1-800-ANALOGD  |            |
|   |                  | <b>Title</b> SHARC AUDIO EZ-EXTENDER<br>OUT9 VIA AD1939C |            |
| <b>Size C</b>   | <b>Board No.</b> | A0223-2008   | <b>Rev</b> |
| <b>Date</b>   | 6-9-2009_15:31   | <b>Sheet</b>   | 20 of 24   |

# OUT10

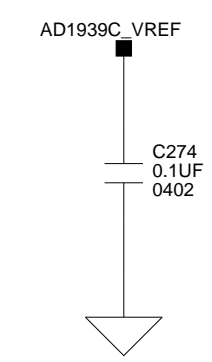
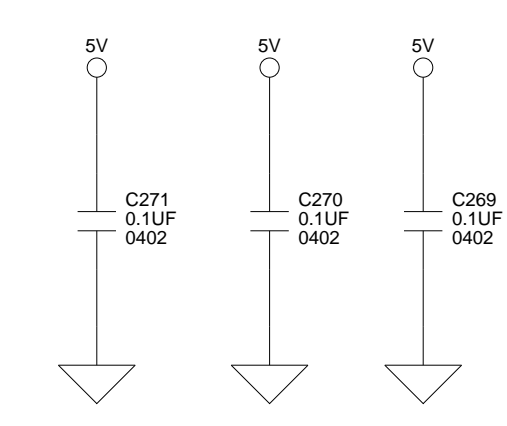
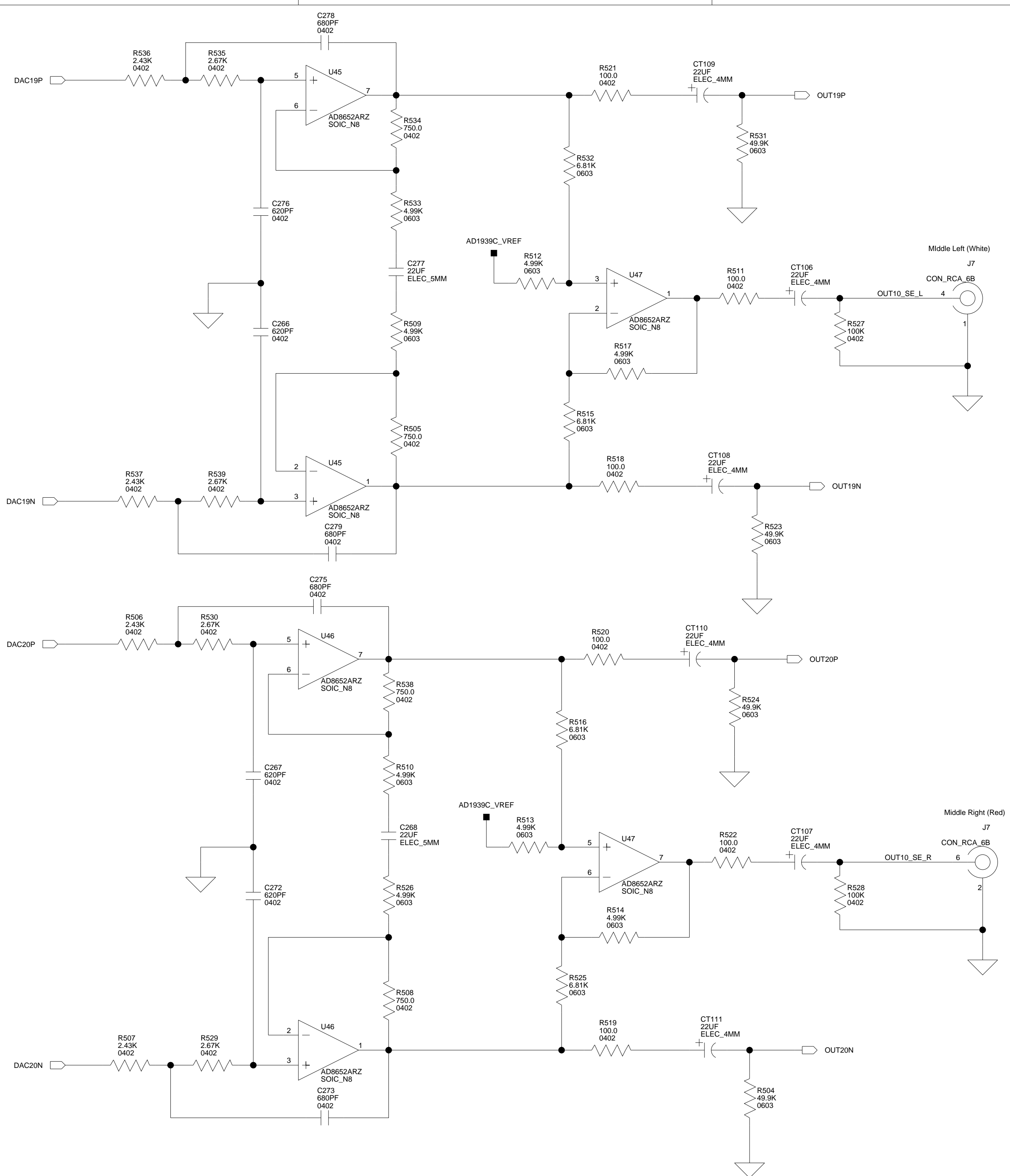

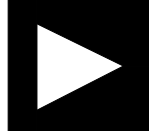
|   |                             |   |  |
|---|-----------------------------|---|--|
|  <b>ANALOG DEVICES</b> |                             | 20 Cotton Road<br>Nashua, NH 03063<br>PH: 1-800-ANALOGD   |  |
|   |                             | <b>Title</b> SHARC AUDIO EZ-EXTENDER<br>OUT10 VIA AD1939C |  |
| <b>Size C</b>   | <b>Board No.</b> A0223-2008 | <b>Rev</b> 0.1  |  |
| <b>Date</b> 6-9-2009_15:31  | <b>Sheet</b> 21 of 24       |   |  |

# OUT11

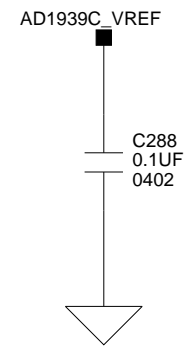
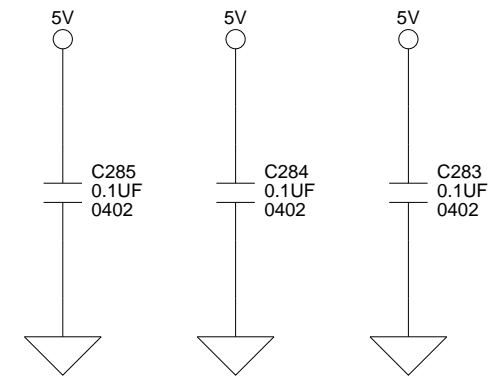
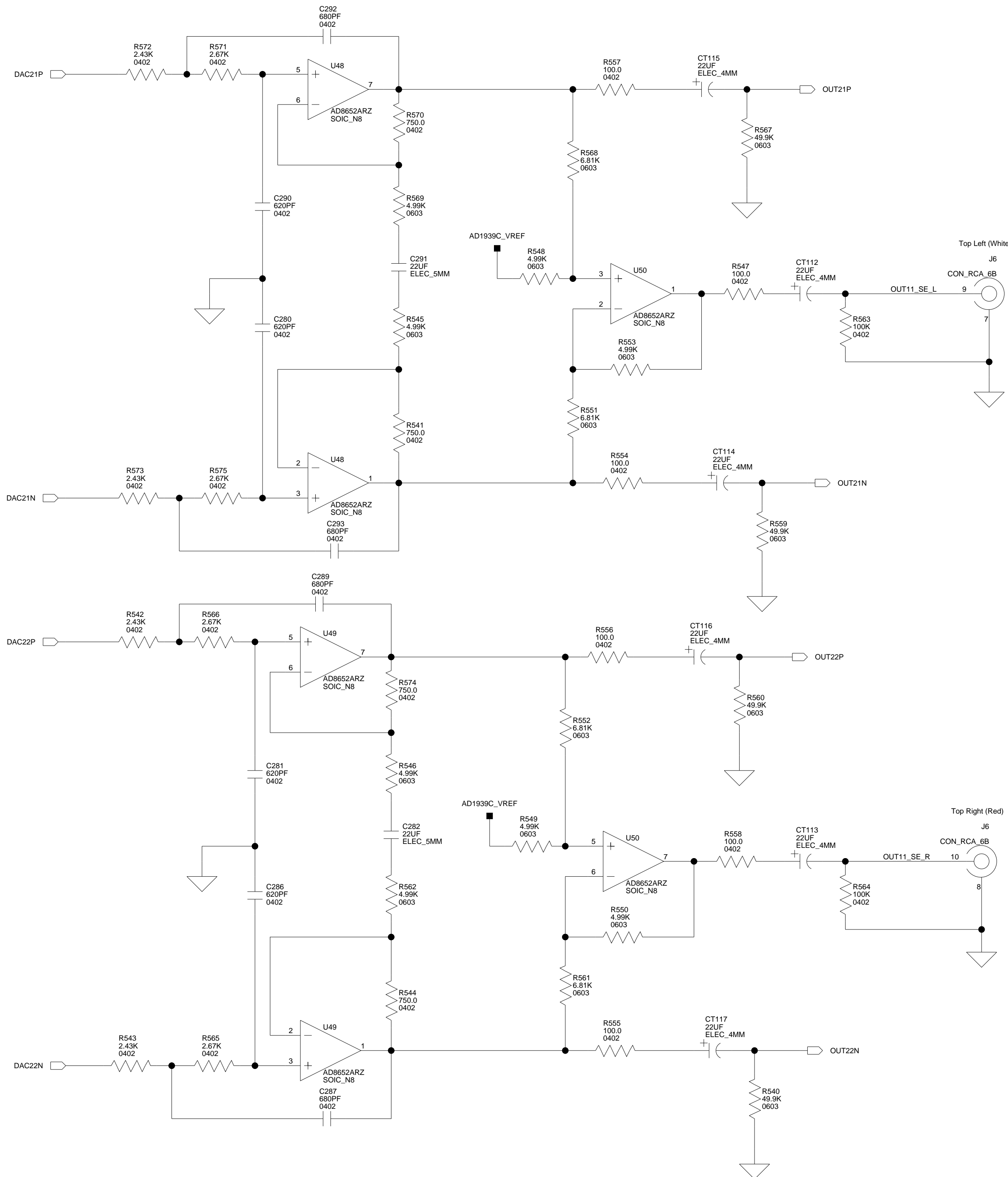

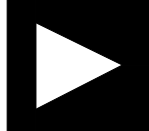
|   |                             |   |  |
|---|-----------------------------|---|--|
|  <b>ANALOG DEVICES</b> |                             | 20 Cotton Road<br>Nashua, NH 03063<br>PH: 1-800-ANALOGD   |  |
|   |                             | <b>Title</b> SHARC AUDIO EZ-EXTENDER<br>OUT11 VIA AD1939C |  |
| <b>Size C</b>   | <b>Board No.</b> A0223-2008 | <b>Rev</b> 0.1  |  |
| <b>Date</b> 6-9-2009_15:31  | <b>Sheet</b> 22 of 24       |   |  |

# OUT12

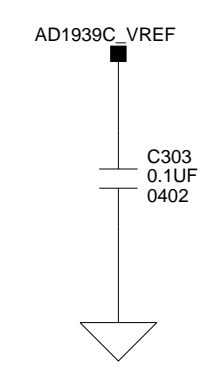
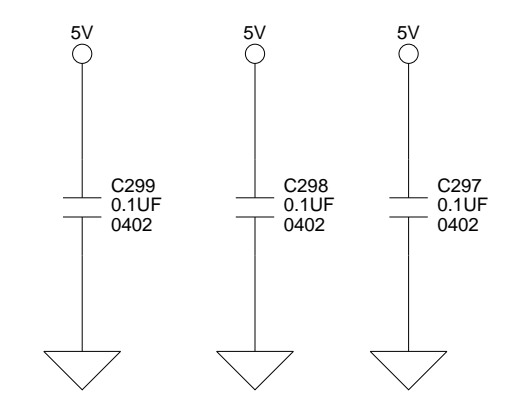
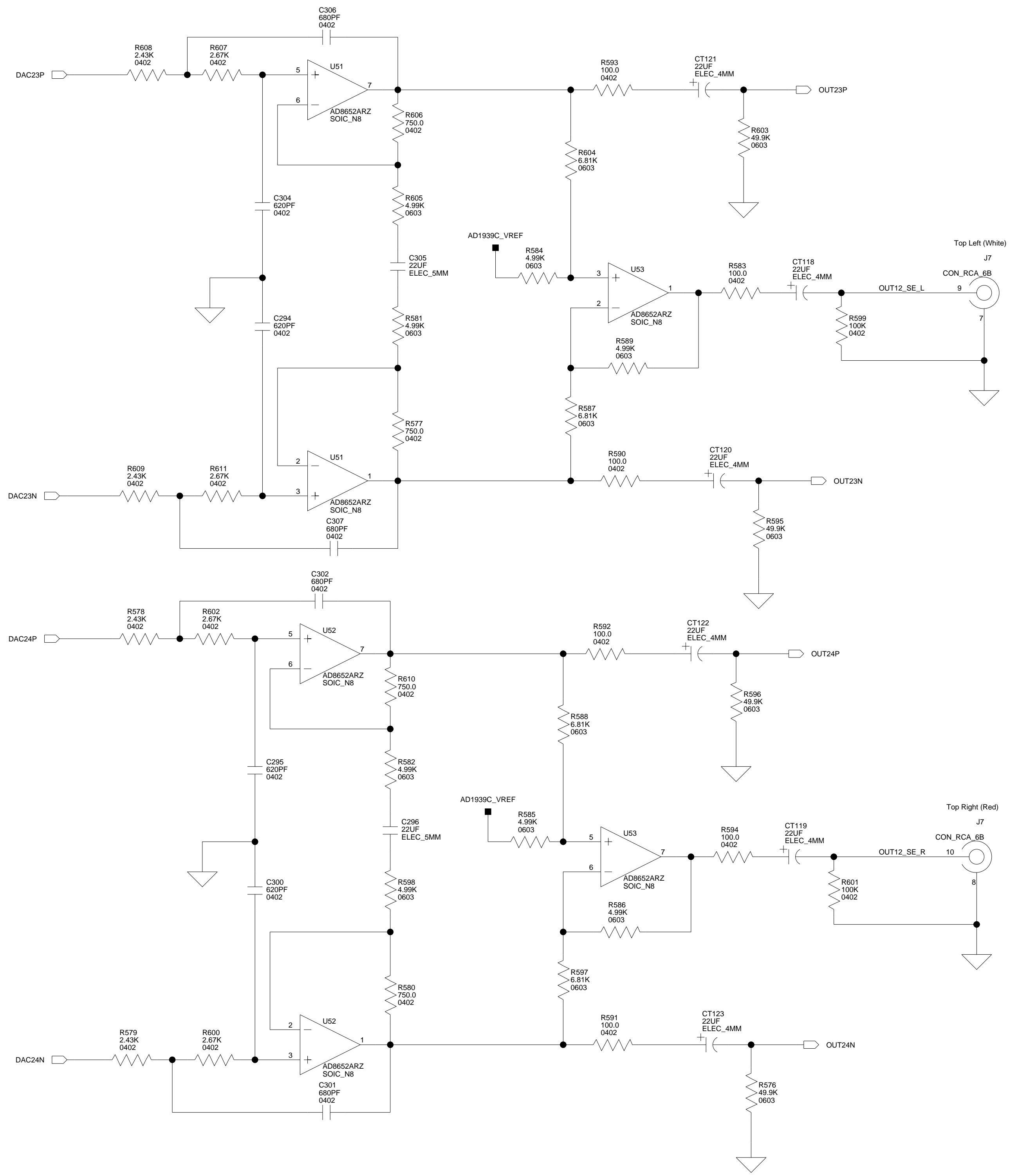

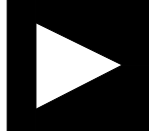
|   |                             |   |  |
|---|-----------------------------|---|--|
|  <b>ANALOG DEVICES</b> |                             | 20 Cotton Road<br>Nashua, NH 03063<br>PH: 1-800-ANALOGD   |  |
|   |                             | <b>Title</b> SHARC AUDIO EZ-EXTENDER<br>OUT12 VIA AD1939C |  |
| <b>Size C</b>   | <b>Board No.</b> A0223-2008 | <b>Rev</b> 0.1  |  |
| <b>Date</b> 6-9-2009_15:31  | <b>Sheet</b> 23 of 24       |   |  |

DB25 Female Connectors for Conversion to XLR Connectors

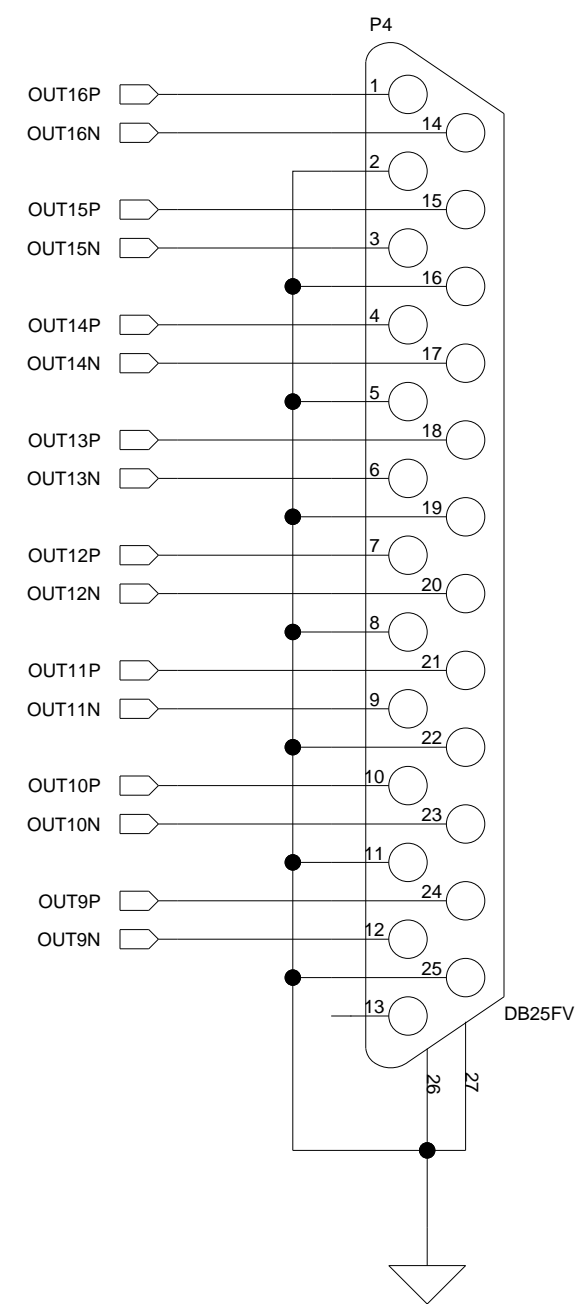
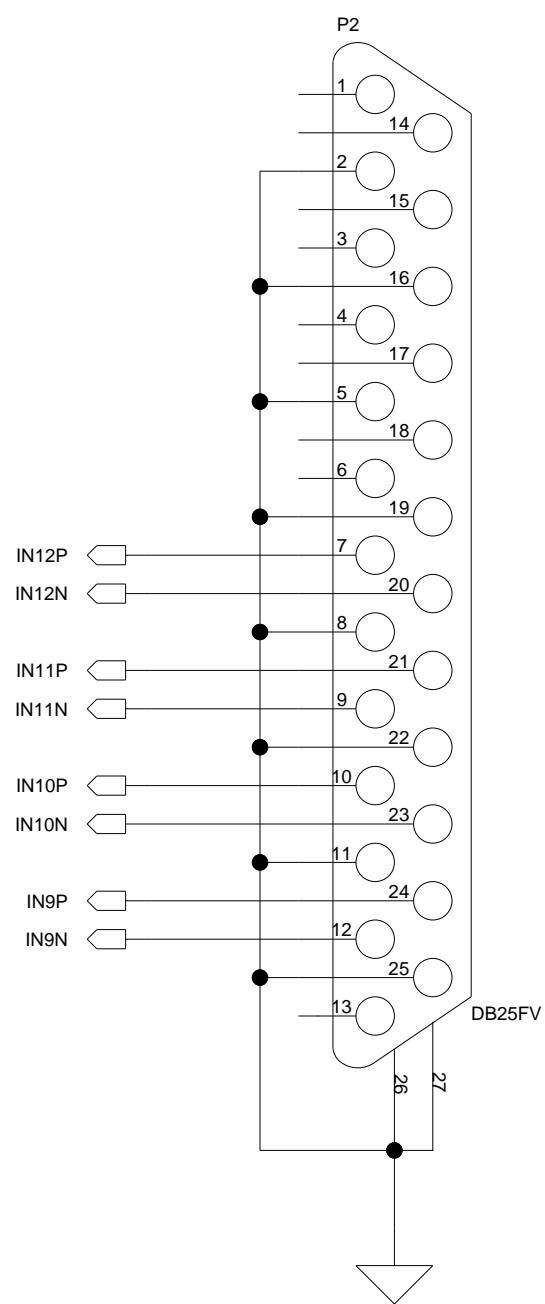
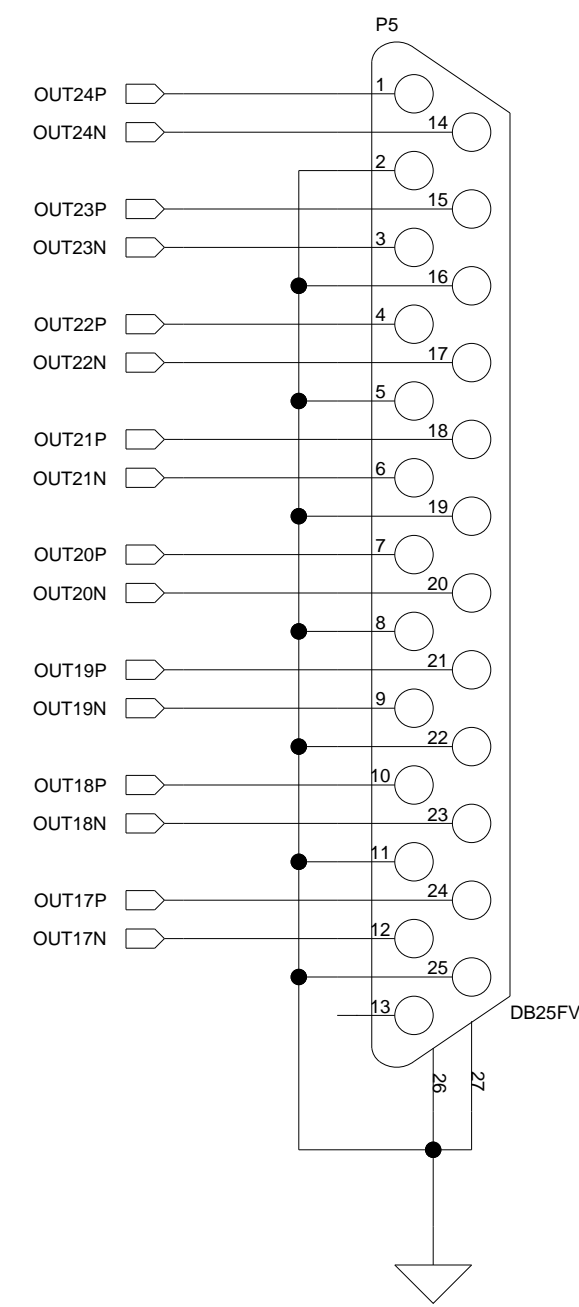
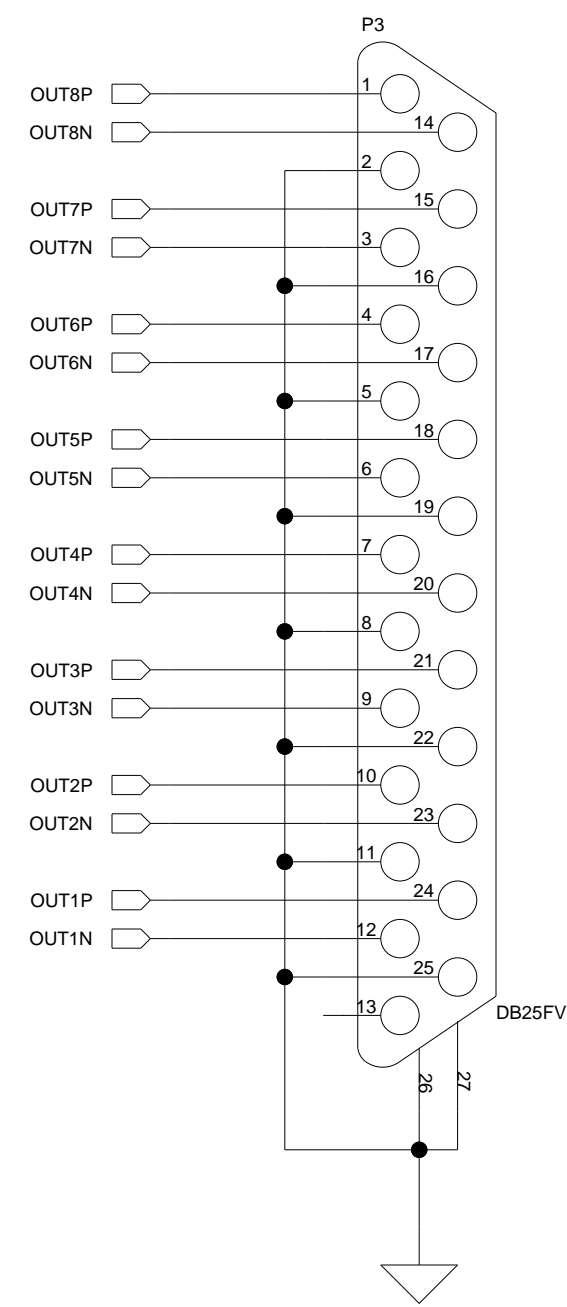
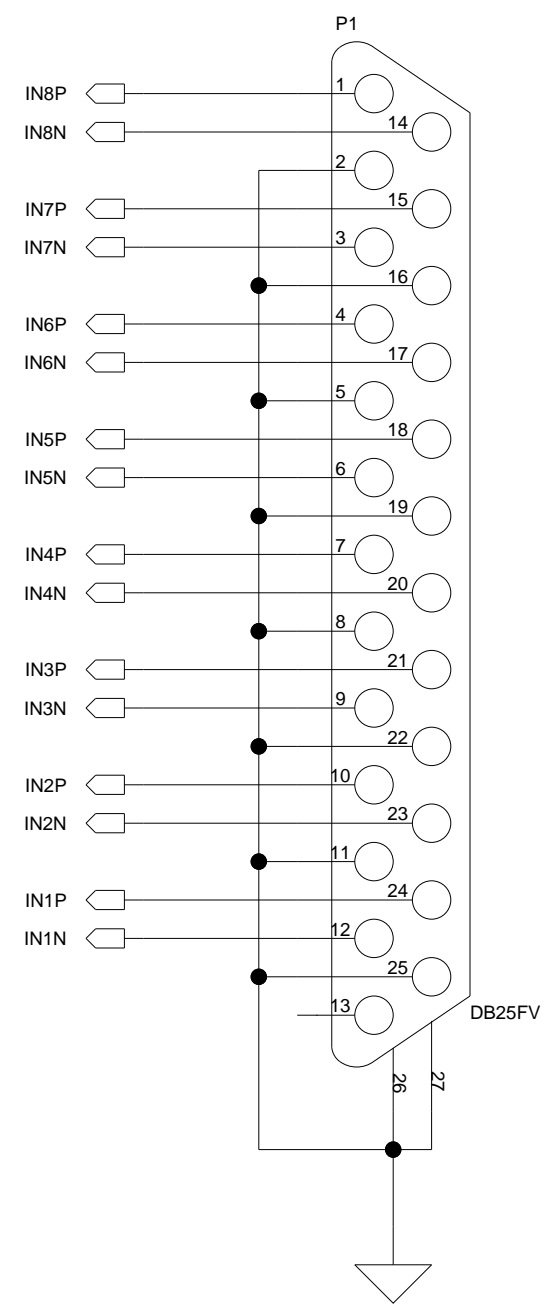

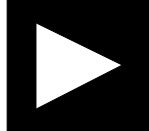
|   |  |                |
|---|--|----------------|
|  <b>ANALOG DEVICES</b> | 20 Cotton Road<br>Nashua, NH 03063<br>PH: 1-800-ANALOGD                  |                |
|   | <b>Title</b> SHARC AUDIO EZ-EXTENDER<br>DIFFERENTIAL AUDIO - DB25 IN/OUT |                |
| <b>Size C</b>   | <b>Board No.</b> A0223-2008  | <b>Rev</b> 0.1 |
| <b>Date</b> 6-9-2009_15:31  | <b>Sheet</b> 24 of 24  |                |

# I INDEX

## A

AD1939 codec

ADC10 circuit, [2-12](#)

ADC11 circuit, [2-13](#)

ADC12 circuit, [2-14](#)

ADC1 circuit, [2-6](#)

ADC2 circuit, [2-7](#)

ADC3 circuit, [2-8](#)

ADC4 circuit, [2-8](#)

ADC5 circuit, [2-9](#)

ADC6 circuit, [2-10](#)

ADC7 circuit, [2-10](#)

ADC8 circuit, [2-11](#)

ADC9 circuit, [2-12](#)

architecture, of this EZ-Extender, [2-2](#)

audio

interface, [1-5](#)

left select switch (SW11), [2-9](#)

left select switch (SW13), [2-10](#)

left select switch (SW15), [2-12](#)

left select switch (SW17), [2-13](#)

left select switch (SW7), [2-6](#)

left select switch (SW9), [2-8](#)

loopback switches (SW1-6), [2-6](#)

RCA connectors (J2-7), [2-18](#)

right select switch (SW10), [2-8](#)

right select switch (SW12), [2-10](#)

right select switch (SW14), [2-11](#)

right select switch (SW16), [2-12](#)

right select switch (SW18), [2-14](#)

right select switch (SW8), [2-7](#)

## B

bill of materials, [A-1](#)

board schematic (SHARC Audio EZ-Extender),  
[B-1](#)

## C

configuration, of SHARC Audio EZ-Extender,  
[1-5](#)

connectors

diagram of locations, [2-17](#)

J1 (expansion interface II), [2-18](#)

J2-7 (RCA audio), [2-18](#)

P1-5 (differential in/out), [2-18](#)

contents, of this EZ-KIT Lite package, [1-2](#)

customer support, [xii](#)

## D

DB25 connectors (P1-5), [2-6](#), [2-7](#), [2-8](#), [2-9](#),  
[2-10](#), [2-11](#), [2-12](#), [2-13](#), [2-14](#), [2-18](#)

default configuration, of this SHARC Audio  
EZ-Extender, [1-3](#)

## E

example programs, [1-7](#)

expansion interface II connector (J1), [2-18](#)

## L

LED1 (power), [2-16](#)

# INDEX

## M

memory config switch (SW19), [2-14](#)

## N

notation conventions, [xvii](#)

## P

package contents, [1-2](#)

power LED (LED1), [2-16](#)

## R

### RCA

audio connectors (J2-7), [2-18](#)

cables, [1-2](#)

## S

schematic, of SHARC Audio EZ-Extender, [B-1](#)

serial port block diagram, [2-3](#)

setup, of SHARC Audio EZ-Extender, [1-3](#), [1-5](#)

soft reset enable switch (SW20), [2-15](#)

SW10 (audio right select) switch, [2-8](#)

SW11 (audio left select) switch, [2-9](#)

SW12 (audio right select) switch, [2-10](#)

SW13 (audio left select) switch, [2-10](#)

SW14 (audio right select) switch, [2-11](#)

SW15 (audio left select) switch, [2-12](#)

SW1-6 (audio loopback) switches, [2-6](#)

SW16 (audio right select) switch, [2-12](#)

SW17 (audio left select) switch, [2-13](#)

SW18 (audio right select) switch, [2-14](#)

SW19 (memory config) switch, [2-14](#)

SW20 (soft reset enable) switch, [2-15](#)

SW7 (audio left select) switch, [2-6](#)

SW8 (audio right select) switch, [2-7](#)

SW9 (audio left select) switch, [2-8](#)

switches, diagram of locations, [2-5](#)

system architecture, of this EZ-Extender, [2-2](#)