

THIS DOCUMENT IS THE PROPERTY OF  
KEYSTONE ELECTRONICS CORP. AND  
SHALL NOT BE REPRODUCED, DISTRIBUTED  
OR USED AS A BASIS FOR MANUFACTURE  
WITHOUT PRIOR WRITTEN PERMISSION  
FROM KEYSTONE ELECTRONICS CORP.

TOP TOOL

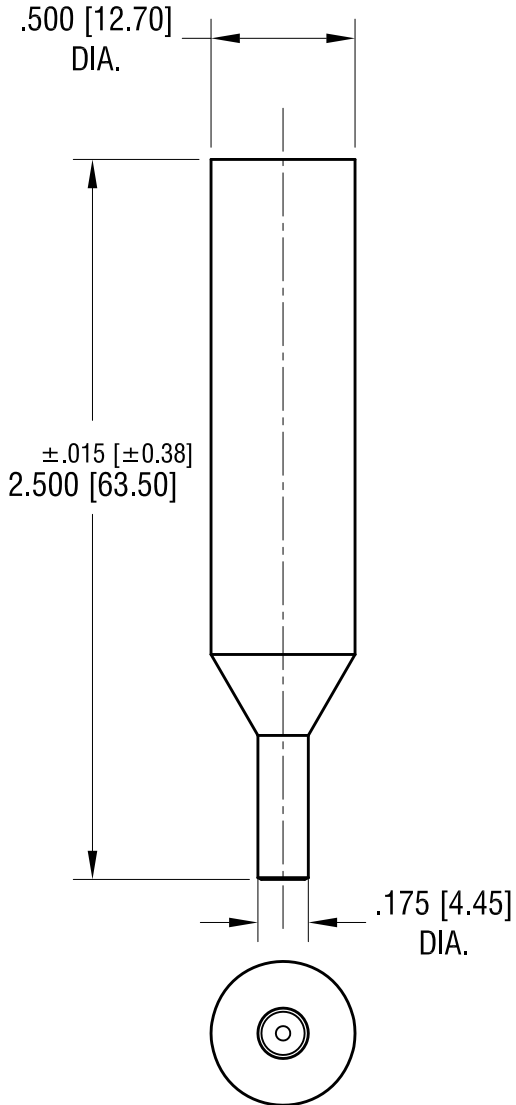

BOTTOM TOOL

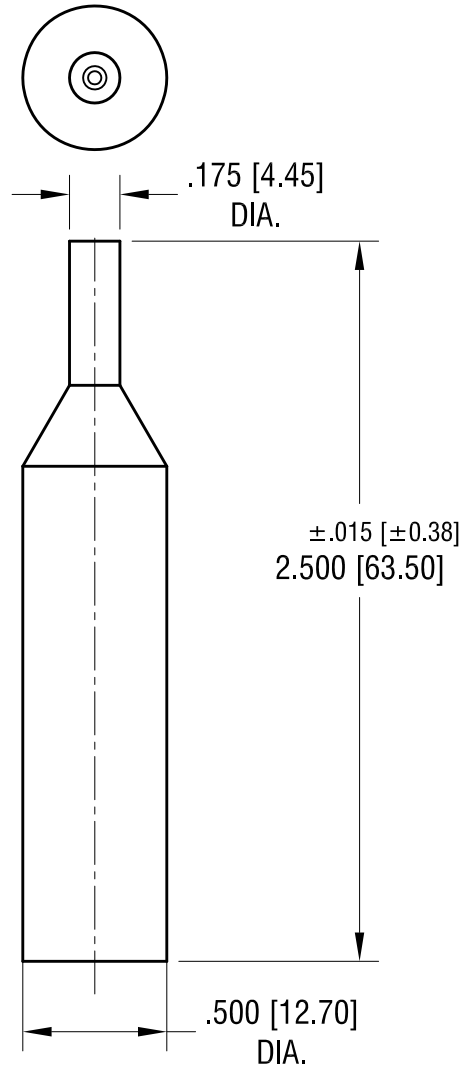

**KEYSTONE ELECTRONICS CORP.**

www.keyelco.com • ASTORIA, N.Y. 11105-2017 • Tel (718) 956-8900

PART NAME

TOP & BOTTOM TOOL

MATERIAL

DRILL ROD

FINISH

DRN BY

NT

DATE

7.22.11

APP'D

LN

SCALE

1.5X

TOLERANCES

INCH

[MM]

CODE

DWG NO.

DECIMAL ±.010 [±0.25]

C

ANGULAR ± 1°  
UNLESS OTHERWISE SPECIFIED

**1633-TL**

DATE

DESCRIPTION

REV.