



MICRF507

470MHz to 510MHz Low-Power FSK Transceiver with +10dBm Power Amplifier

General Description

The MICRF507 is a fully-integrated FSK transceiver with +10dBm power amplifier and transmit/receive switch. The device is targeted at automated meter reading (AMR) applications in the China Short Range Device (SRD) frequency band of 470MHz to 510MHz. The device supports data rates up to 20kbps with PLL divider modulation and up to 200kbps with VCO modulation. The receiver achieves a sensitivity of -113dBm at a data rate of 2.4kbps while only consuming 12mA of supply current. The integrated power amplifier (PA) delivers +10dBm of output power while only consuming 21.5mA of supply current. Power down supply current is a low 0.2 μ A while retaining register information and a low 280 μ A in standby mode where only the crystal oscillator is enabled.

The receiver of the MICRF507 utilizes a Zero IF (ZIF) I/Q architecture, integrating a low-noise amplifier (LNA) with bypass mode, I/Q quadrature mixers, three-pole Sallen-Key IF channel pre-filters, and six-pole elliptic switched capacitor IF filters, providing excellent selectivity, adjacent channel rejection and blocking performance. FSK demodulation is implemented digitally and a synchronizer, when enabled, recovers the received bit clock. A receive signal strength indicator (RSSI) circuit indicates the received signal level over a 50dB range. An integrated Frequency Error Estimator (FEE) and crystal tuning capability allow fine tuning of the RF frequency.

The transmitter of the MICRF507 consists of an FSK modulator and power amplifier with output power adjustable from +10dBm to -3.5dBm in seven steps. Modulation can be achieved by applying two sets of PLL divider ratios or through direct VCO modulation by varying VCO tank capacitance.

The MICRF507 requires a 2.0V to 2.5V supply voltage, operates over the -40°C to +85°C temperature range, and is available in a 32-pin QFN package.



RadioWire®

Features

- -113dBm sensitivity at 2.4kbps encoded bit rate
- +10dBm power amplifier with seven gain steps
- 12mA receive supply current
- 21.5mA transmit supply current at +10dBm
- 0.2 μ A power down current (registers retain settings)
- 280 μ A standby current (crystal oscillator enabled)
- Data rates up to 20kbps with PLL divider modulation
- Data rates up to 200kbps with VCO modulation
- Integrated transmit and receive (T/R) switch
- LNA with bypass mode
- Zero IF I/Q receiver architecture
- IF pre-amplifiers with DC-offset removal
- Three-pole Sallen-Key IF channel low-pass pre-filter
- Six-pole elliptic switched capacitor IF low-pass filter
- 50kHz to 350kHz programmable baseband bandwidth
- 59dB blocking at \pm 1MHz offset
- 53dB adjacent channel rejection at \pm 500kHz offset
- FSK digital demodulator with clock recovery
- 50dB Received Signal Strength Indicator (RSSI)
- Frequency Error Estimator (FEE)
- Reference crystal tuning capability
- 2.0 to 2.5V supply voltage range
- -40°C to +85°C operating temperature range
- Available in 32-pin QFN package (5.0mm x 5.0mm x 0.85mm)

Applications

- China Short Range Device (SRD) Communications
- Automated Meter Reading (AMR)
- Advanced Metering Infrastructure (AMI)
- Wireless Remote Meter Reading

RadioWire is a registered trademark of Micrel, Inc.

Micrel Inc. • 2180 Fortune Drive • San Jose, CA 95131 • USA • tel +1 (408) 944-0800 • fax +1 (408) 474-1000 • <http://www.micrel.com>

October 2, 2013

Revision 2.2

| | |
|--|-----------|
| RadioWire® FSK Transceiver Selection Guide | 4 |
| Ordering Information | 4 |
| Pin Configuration | 4 |
| Pin Description | 4 |
| Block Diagram | 6 |
| Absolute Maximum Ratings | 7 |
| Operating Ratings | 7 |
| Electrical Characteristics | 7 |
| Functional Description | 10 |
| Control (3-wire) Interface | 10 |
| Reading | 13 |
| Control Interface Timing..... | 14 |
| Power-on Reset | 14 |
| Clock Generation | 15 |
| Crystal Oscillator (XCO) | 16 |
| BITSYNC_CLK (Receiver Bit Synchronization Clock)..... | 17 |
| BITRATE_CLK (Transmitter Bit Rate Clock) | 17 |
| MODULATOR_CLK (VCO Modulator Clock)..... | 17 |
| Data Interface and Bit Synchronization | 17 |
| Sync_en = 0 | 19 |
| Sync_en = 1 | 19 |
| Additional Considerations in the Use of Synchronizer (Sync_en = 1) | 19 |
| Frequency Synthesizer | 20 |
| VCO..... | 22 |
| Charge Pump | 22 |
| PLL Filter | 22 |
| Lock Detect | 23 |
| Receiver | 24 |
| Front End..... | 24 |
| Sallen-Key Filters | 25 |
| Switched Capacitor Filter | 25 |
| RSSI | 25 |
| FEE | 26 |
| XCOtune Procedure Example | 27 |
| Transmitter | 28 |
| Power Amplifier | 28 |
| Frequency Modulation..... | 29 |
| Divider Modulation | 30 |
| VCO Modulation and the Modulator..... | 30 |
| Modulator Filter | 32 |
| System Modes and Initialization | 33 |
| Start-up and Initialization..... | 33 |
| Modes of Operation..... | 33 |
| Mode Transitions..... | 33 |
| Message Coding and Formatting | 34 |
| DC Balanced Line Coding..... | 34 |
| Message Formatting: Preamble | 34 |
| Typical Application | 35 |

| | |
|--|-----------|
| Bill of Materials | 36 |
| Layout Considerations | 37 |
| Layer Definition | 37 |
| Grounding..... | 37 |
| RF Traces..... | 37 |
| Supply Routing..... | 37 |
| PLL Loop Filter..... | 37 |
| Overview of Programming Bits | 38 |
| Detailed Description of Programming Bits | 39 |
| Package Information and Recommended Landing Pattern | 46 |

RadioWire® FSK Transceiver Selection Guide

| Part Number | Frequency Range | Maximum Data Rate | Receive Current | Supply Voltage | Transmit Current | Package |
|-------------|------------------|-------------------|-----------------|----------------|------------------|---------|
| MICRF505 | 850MHz to 950MHz | 200kbps | 13.5mA | 2.0 to 2.5V | 28mA | QFN-32 |
| MICRF505L | 850MHz to 950MHz | 200kbps | 13.5mA | 2.25 to 5.5V | 28mA | QFN-32 |
| MICRF506 | 410MHz to 450MHz | 200kbps | 12mA | 2.0 to 2.5V | 21.5mA | QFN-32 |
| MICRF507 | 470MHz to 510MHz | 200kbps | 12mA | 2.0 to 2.5V | 21.5mA | QFN-32 |

Ordering Information

| Part Number | Junction Temperature Range | Package |
|----------------|----------------------------|--------------------|
| MICRF507YML TR | -40° to +85°C | Pb-Free 32-Pin QFN |

Pin Configuration

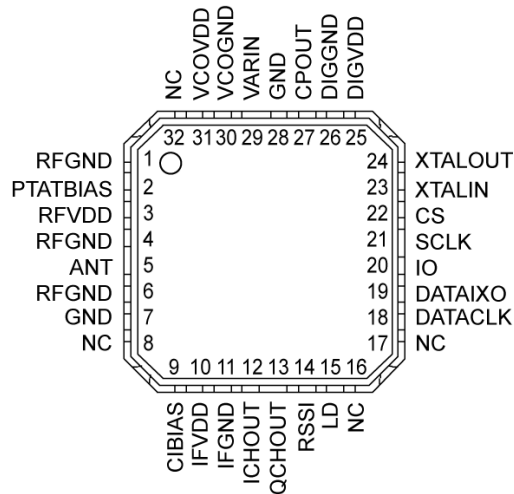

32-Pin QFN

Pin Description

| Pin Number | Pin Name | Type | Pin Function |
|------------|----------|------|-------------------------------|
| 1 | RFGND | | LNA and PA ground. |
| 2 | PTATBIAS | O | Connection for bias resistor. |
| 3 | RFVDD | | LNA and PA power supply. |
| 4 | RFGND | | LNA and PA ground. |
| 5 | ANT | I/O | Antenna Input/Output. |
| 6 | RFGND | | LNA and PA ground. |
| 7 | RFGND | | LNA and PA ground. |

Pin Description (Continued)

| Pin Number | Pin Name | Type | Pin Function |
|---------------|----------------|------|--|
| 8, 16, 17, 32 | NC | | No connect. Leave these pins floating. |
| 9 | CIBIAS | O | Connection for bias resistor. |
| 10 | IFVDD | | IF/mixer power supply. |
| 11 | IFGND | | IF/mixer ground. |
| 12 | ICHOUT | O | Test pin. |
| 13 | QCHOUT | O | Test pin. |
| 14 | RSSI | O | Received signal strength indicator. |
| 15 | LD | O | PLL lock indicator. |
| 18 | DATACLK | O | RX/TX data clock output. |
| 19 | DATAIXO | I/O | RX/TX data input/output. |
| 20 | IO | I/O | 3-wire interface data in/output |
| 21 | SCLK | I | 3-wire interface serial clock. |
| 22 | CS | I | 3-wire interface chip select. |
| 23 | XTALIN | I | Crystal oscillator input. |
| 24 | XTALOUT | I/O | Crystal oscillator output or external reference input. |
| 25 | DIGVDD | | Digital power supply. |
| 26 | DIGGND | | Digital ground. |
| 27 | CPOUT | O | PLL charge pump output. |
| 28 | GND | | Substrate ground. |
| 29 | VARIN | I | VCO varactor tune voltage input. |
| 30 | VCOGND | | VCO ground. |
| 31 | VCOVDD | | VCO power supply. |
| | Exposed Paddle | | Ground. |

Block Diagram

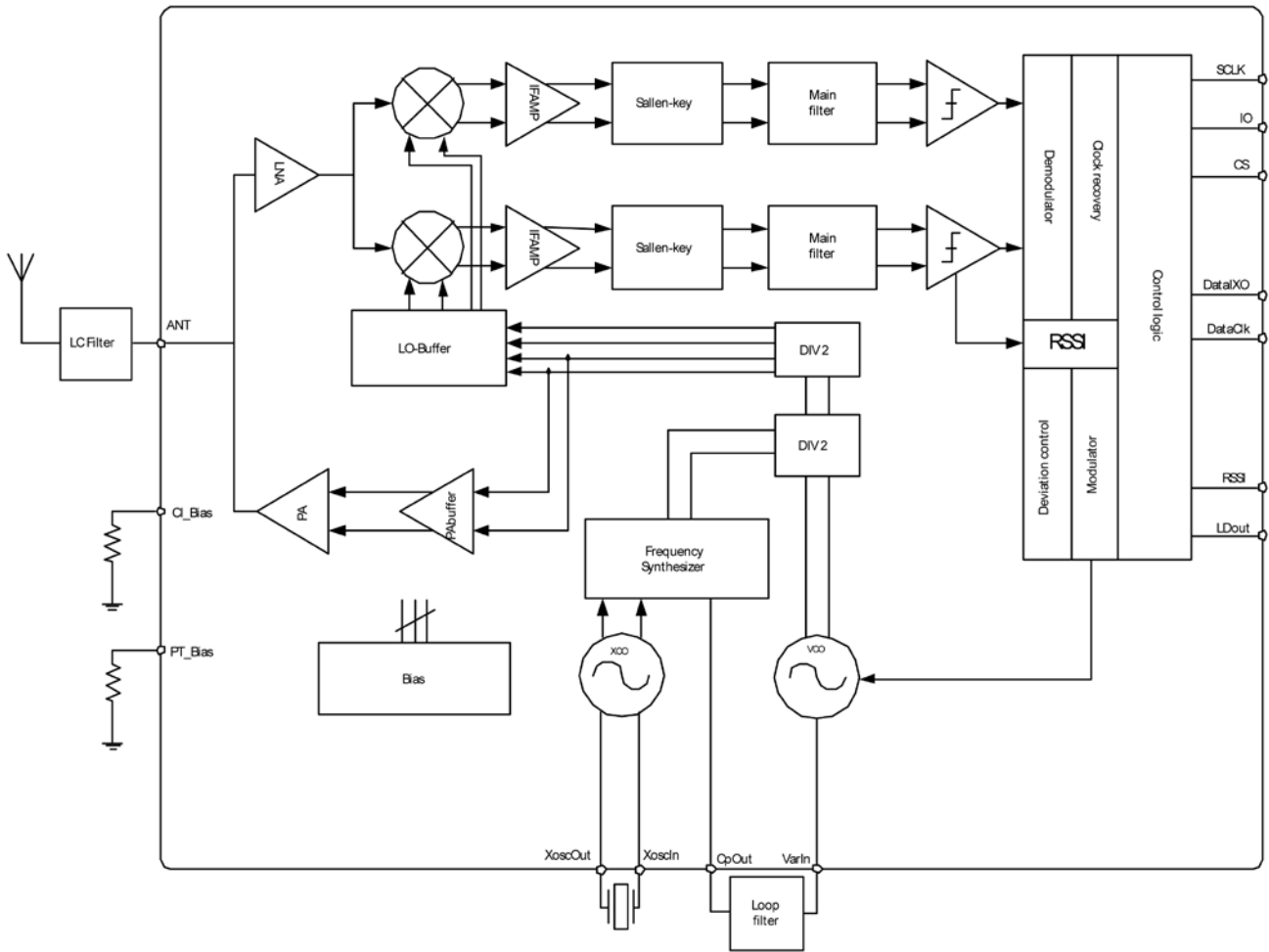

Absolute Maximum Ratings⁽¹⁾

| | |
|-------------------------------------|-----------------|
| Supply Voltage (V_{DD}) | +2.7V |
| Voltage on any pin (GND = 0V) | -0.3V to +2.7V |
| Lead Temperature (soldering, 4sec.) | 300°C |
| Storage Temperature (T_s) | -55°C to +150°C |
| ESD Rating ⁽³⁾ | 2kV |

Operating Ratings⁽²⁾

| | |
|-------------------------------|------------------|
| Supply Voltage (V_{IN}) | +2.0V to +2.5V |
| RF Frequencies | 470MHz to 510MHz |
| Encoded Bit Rate | 200kbps |
| Ambient Temperature (T_A) | -40°C to +85°C |
| Package Thermal Resistance | |
| 32-Pin QFN (θ_{JA}) | 41.7°C/W |

Electrical Characteristics⁽⁴⁾

$f_{RF} = 490\text{MHz}$, $f_{XTAL} = 16\text{MHz}$, MICRF507 Development Board, Modulation type = closed-loop VCO modulation, Sync_en bit = 1, $V_{DD} = 2.5\text{V}$; $T_A = 25^\circ\text{C}$, the term "bit rate" refers to encoded bit rate throughout the EC table (see Figure 24), **bold** values indicate $-40^\circ\text{C} < T_A < +85^\circ\text{C}$, unless noted.

| Symbol | Parameter | Condition | Min | Typ | Max | Units |
|----------------------------|--|---------------------------------------|------------|---------|------------|---------------|
| f_{RF} | RF Frequency Operating Range | | 470 | | 510 | MHz |
| V_{DD} | Power Supply | | | 2.5 | | V |
| | Power Down Current | | | 0.2 | 3 | μA |
| | Standby Current | | | 280 | | μA |
| VCO and PLL Section | | | | | | |
| | Reference Frequency | | 4 | | 40 | MHz |
| | PLL Lock Time, 3kHz Bandwidth | 490MHz to 490.5MHz | | 0.7 | | ms |
| | | 485MHz to 495MHz | | 1.3 | | ms |
| | PLL Lock Time, 20kHz Bandwidth | 490MHz to 490.5MHz | | 0.3 | | ms |
| | Switch Time, 3kHz Loop Bandwidth | Rx – Tx | | 1.0 | | ms |
| | | Tx – Rx | | 1.0 | | |
| | | Standby to Rx | | 1.0 | | |
| | | Standby to Tx | | 1.0 | | |
| | Crystal Oscillator Start-Up Time | With MICRF507 development board BOM | | 1.0 | | ms |
| | Charge Pump Current | $V_{CPOUT} = 1.1\text{V}$, CP_HI = 0 | 100 | 125 | 170 | μA |
| | | $V_{CPOUT} = 1.1\text{V}$, CP_HI = 1 | 420 | 500 | 680 | μA |
| Transmit Section | | | | | | |
| P_{OUT} | Output Power | $R_{LOAD} = 50\Omega$, PA[2:0] = 111 | | 10 | | dBm |
| | | $R_{LOAD} = 50\Omega$, PA[2:0] = 001 | | -3.5 | | dBm |
| | Output Power Variation Relative to $V_{DD} = 2.5\text{V}$, $T_A = 25^\circ\text{C}$ | Over temperature range | | ± 1 | | dB |
| | | $V_{DD} = 2.0\text{V}$ | | -2 | | dB |
| | Transmit Mode Current Consumption | $R_{LOAD} = 50\Omega$, PA[2:0] = 111 | | 21.5 | | mA |
| | | $R_{LOAD} = 50\Omega$, PA[2:0] = 001 | | 10.5 | | mA |
| | | $R_{LOAD} = 50\Omega$, PA[2:0] = 000 | | 8.0 | | mA |

Notes:

- Exceeding the absolute maximum rating may damage the device.
- The device is not guaranteed to function outside its operating rating.
- Devices are ESD sensitive. Handling precautions recommended. Human body model; 1.5k in series with 100pF.
- Specification for packaged product only.

Electrical Characteristics⁽⁴⁾ (Continued)

$f_{RF} = 490\text{MHz}$, $f_{XTAL} = 16\text{MHz}$, MICRF507 Development Board, Modulation type = closed-loop VCO modulation, Sync_en bit = 1, $V_{DD} = 2.5\text{V}$; $T_A = 25^\circ\text{C}$, the term "bit rate" refers to encoded bit rate throughout the EC table (see Figure 24), **bold** values indicate $-40^\circ\text{C} < T_A < +85^\circ\text{C}$, unless noted.

| Symbol | Parameter | Condition | Min | Typ | Max | Units |
|------------------------|---|--|-----|------|-----|-------|
| | Single-Sided Frequency Deviation ⁽⁵⁾ | | 10 | | 250 | kHz |
| | Maximum Bit Rate | VCO modulation | | 200 | | kbps |
| | | Divider modulation | | 20 | | kbps |
| | Occupied Bandwidth ⁽⁵⁾ | 38.4kbps, $\beta = 2$, 20dBc | | 140 | | kHz |
| | | 125kbps, $\beta = 2$, 20dBc | | 550 | | kHz |
| | | 200kbps, $\beta = 2$, 20dBc | | 800 | | kHz |
| | 2 nd Harmonic ⁽⁵⁾ | | | -43 | -36 | dBm |
| | 3 rd Harmonic ⁽⁵⁾ | | | -59 | -36 | dBm |
| | Spurious Emission in Restricted Bands < 1GHz ⁽⁵⁾ | | | | -54 | dBm |
| | Spurious Emission < 1GHz ⁽⁵⁾ | | | | -36 | dBm |
| | Spurious Emission > 1GHz ⁽⁵⁾ | | | | -30 | dBm |
| Receive Section | | | | | | |
| | Rx Current Consumption | All Functions on | | 12 | | mA |
| | | LNA bypassed | | 10.3 | | |
| | | Switch cap filter bypassed, LNA on | | 9.8 | | |
| | | Both switch cap filter and LNA bypassed | | 8 | | |
| | Rx Current Consumption Variation | Over temperature | | 2 | | mA |
| | Receiver Sensitivity (BER 10^{-3}) | 2.4kbps, $\beta = 16$ | | -113 | | dBm |
| | | 4.8kbps, $\beta = 16$ | | -111 | | |
| | | 19.2kbps, $\beta = 4$ | | -107 | | |
| | | 38.4kbps, $\beta = 4$ | | -104 | | |
| | | 76.8kbps, $\beta = 2$ | | -101 | | |
| | | 125kbps, $\beta = 2$ | | -100 | | |
| | Receiver Maximum Input Power | 125kbps, 125kHz deviation, LNA on | | +7 | | dBm |
| | | 125kbps, 125kHz deviation, LNA bypassed | | +12 | | |
| | | 20kbps, 40kHz deviation | | +2 | | |
| | Receiver Sensitivity Tolerance | Over temperature | | 2 | | dB |
| | | Over power supply range | | 1 | | dB |
| | Receiver Baseband Bandwidth | | 50 | | 350 | kHz |
| | Co-Channel Rejection, BER = 10^{-3} | 19.2kbps, $\beta = 6$, PF_FC[1:0] = 01, $f_{CUT} = 133\text{kHz}$ | | -8 | | dB |

Note:

5. Guaranteed by design.

Electrical Characteristics⁽⁴⁾ (Continued)

$f_{RF} = 490\text{MHz}$, $f_{XTAL} = 16\text{MHz}$, MICRF507 Development Board, Modulation type = closed-loop VCO modulation, Sync_en bit = 1, $V_{DD} = 2.5\text{V}$; $T_A = 25^\circ\text{C}$, the term "bit rate" refers to encoded bit rate throughout the EC table (see Figure 24), **bold** values indicate $-40^\circ\text{C} < T_A < +85^\circ\text{C}$, unless noted.

| Symbol | Parameter | Condition | Min. | Typ. | Max. | Units |
|-------------------------------|--|------------------------------|--------------------------------|-------|--------------------------------|----------|
| | Adjacent Channel Rejection, both interferer and desired signal are modulated at 19.2 kbps encoded bit rate, $\beta = 6$, PF_FC[1:0] = 01, $f_{CUT} = 133\text{kHz}$, BER = 10^{-3} | $\pm 500\text{kHz}$ spacing | | 53 | | dB |
| | | $\pm 1\text{MHz}$ spacing | | 58 | | dB |
| | CW Blocking above desired signal, desired signal is modulated at 19.2kbps, $\beta = 6$, 3dB above sensitivity, PF_FC[1:0] = 01, $f_{CUT} = 133\text{kHz}$, BER = 10^{-3} | $\pm 1\text{MHz}$ | | 59 | | dB |
| | | $\pm 2\text{MHz}$ | | 60 | | dB |
| | | $\pm 5\text{MHz}$ | | 47 | | dB |
| | | $\pm 10\text{MHz}$ | | 60 | | dB |
| P_{1dB} | 1dB Compression | | | -34 | | dBm |
| | Input IP3 | 2 tones with 1MHz separation | | -25 | | dBm |
| | LO Leakage | | | -90 | | dBm |
| | Spurious Emission ⁽⁵⁾ | <1GHz | | | -57 | dBm |
| | | >1GHz | | | -47 | dBm |
| | Input Impedance with no matching components | | | 33+7j | | Ω |
| | RSSI Dynamic Range | | | 50 | | dB |
| | RSSI Output Range | $P_{IN} = -110\text{dBm}$ | | 0.9 | | V |
| | | $P_{IN} = -60\text{dBm}$ | | 2 | | V |
| Digital Inputs/Outputs | | | | | | |
| V_{IH} | Logic Input High | | 0.7*V_{DD} | | V_{DD} | V |
| V_{IL} | Logic Input Low | | 0 | | 0.3*V_{DD} | V |
| | Clock/Data Frequency ⁽⁵⁾ | | | | 10 | MHz |
| | Clock/Data Duty Cycle ⁽⁵⁾ | | 45 | | 55 | % |

Functional Description

Control (3-wire) Interface

General

The MICRF507 operation is controlled through a set of 8-bit registers. The chip has a total of 23 readable registers (addresses 0-22) of which 22 (addresses 0-21) are writeable. Through this register set, the user can set the MICRF507 in transmit or receive mode, program the carrier frequency, and select a bit rate, among other options.

Table 1 identifies all register bits. Table 26 gives more detail and Table 27 shows the register fields grouped by category, with don't-care and mandatory bits omitted. Some bits shown as '0' or '1' are mandatory bits and must always be written with the values given. Other bits marked as "-" are "don't care" bits.

Registers are accessed serially through the control interface consisting of the CS, IO, and SCLK pins.

Positive-going pulses at SCLK serve to clock bits in and out of IO at a rate determined by the user. When IO is an input, falling edges of SCLK strobe each bit in; when IO is an output, each bit appears at IO after the rising edge of SCLK.

The IO is an input for entry of starting addresses, the R/W bit, and bytes being written to registers, and an output for bytes read from registers.

CS enables transactions at the control interface, active high. Transitions at the other two pins are ignored when CS is low. This allows the MICRF507 to share SCLK and IO with other devices as long as they have separate CS lines.

To start a transaction (with SCLK and CS initially low), bring CS high. To end a transaction (with SCLK low), bring CS low.

To write a bit into IO (when IO is an input); first bring SCLK high and drive IO with the bit level to be input (in either order, or simultaneously). Then bring SCLK low.

To read a bit out of IO (when IO is an output); first bring SCLK high and read the level on IO. Then bring SCLK low (in either order, or simultaneously).

The first byte to be clocked in during a transaction is made of seven bits (MSB first) of register address followed by the R/W bit, 0 for write, 1 for read. Then, one or more bytes to be written to or read from registers are clocked in or out respectively, always MSB first.

| Adr | Data Field | | | | | | | |
|---------|---------------|---------------|-----------|-----------|---------------|---------------|---------------|---------------|
| | D7 | D6 | D5 | D4 | D3 | D2 | D1 | D0 |
| 0000000 | LNA_by | PA2 | PA1 | PA0 | Sync_en | Mode1 | Mode0 | '1' |
| 0000001 | Modulation1 | Modulation0 | '0' | '0' | RSSI_en | LD_en | PF_FC1 | PF_FC0 |
| 0000010 | CP_HI | SC_by | '0' | PA_By | OUTS3 | OUTS2 | OUTS1 | OUTS0 |
| 0000011 | '1' | '1' | '0' | VCO_IB2 | VCO_IB1 | VCO_IB0 | VCO_freq1 | VCO_freq0 |
| 0000100 | Mod_F2 | Mod_F1 | Mod_F0 | Mod_I4 | Mod_I3 | Mod_I2 | Mod_I1 | Mod_I0 |
| 0000101 | - | - | '0' | '1' | Mod_A3 | Mod_A2 | Mod_A1 | Mod_A0 |
| 0000110 | - | Mod_clkS2 | Mod_clkS1 | Mod_clkS0 | BitSync_clkS2 | BitSync_clkS1 | BitSync_clkS0 | BitRate_clkS2 |
| 0000111 | BitRate_clkS1 | BitRate_clkS0 | RefClk_K5 | RefClk_K4 | RefClk_K3 | RefClk_K2 | RefClk_K1 | RefClk_K0 |
| 0001000 | '1' | '1' | '0' | ScClk4 | ScClk3 | ScClk2 | ScClk1 | ScClk0 |
| 0001001 | '0' | '0' | '1' | XCOtune4 | XCOtune3 | XCOtune2 | XCOtune1 | XCOtune0 |
| 0001010 | - | - | A0_5 | A0_4 | A0_3 | A0_2 | A0_1 | A0_0 |
| 0001011 | - | - | - | - | N0_11 | N0_10 | N0_9 | N0_8 |
| 0001100 | N0_7 | N0_6 | N0_5 | N0_4 | N0_3 | N0_2 | N0_1 | N0_0 |
| 0001101 | - | - | - | - | M0_11 | M0_10 | M0_9 | M0_8 |
| 0001110 | M0_7 | M0_6 | M0_5 | M0_4 | M0_3 | M0_2 | M0_1 | M0_0 |
| 0001111 | - | - | A1_5 | A1_4 | A1_3 | A1_2 | A1_1 | A1_0 |
| 0010000 | - | - | - | - | N1_11 | N1_10 | N1_9 | N1_8 |
| 0010001 | N1_7 | N1_6 | N1_5 | N1_4 | N1_3 | N1_2 | N1_1 | N1_0 |
| 0010010 | - | - | - | - | M1_11 | M1_10 | M1_9 | M1_8 |
| 0010011 | M1_7 | M1_6 | M1_5 | M1_4 | M1_3 | M1_2 | M1_1 | M1_0 |
| 0010100 | '1' | '0' | '1' | '0' | '0' | '0' | '1' | '1' |
| 0010101 | - | - | - | - | FEEC_3 | FEEC_2 | FEEC_1 | FEEC_0 |
| 0010110 | FEE_7 | FEE_6 | FEE_5 | FEE_4 | FEE_3 | FEE_2 | FEE_1 | FEE_0 |

Names of programming bits. Unused bits ("-") and mandatory bits ("1" or "0") are shown. Changes to mandatory bits may cause malfunction.

Table 1. Control Registers

Writing

This method is used to write either to one register (see Figure 1), or any number of registers with consecutive addresses up to all 22 writeable registers (see Figure 2) in a single transaction.

Procedure:

- Bring CS active (high). IO is initially an input (and remains so for the duration of the transaction).
- Clock in a byte consisting of the address bits and the R/W bit. The first seven bits are the address (starting with MSB) of the register, or the first register if more than one, to be written. The eighth bit is the R/W bit, which is 0 as this is a write operation.

- Clock in one or more bytes, MSB of each byte first.
- Bring CS low to end the transaction.

Bits passing through IO are clocked serially into pre-buffers, then transferred in parallel to the actual registers upon de-assertion of CS.

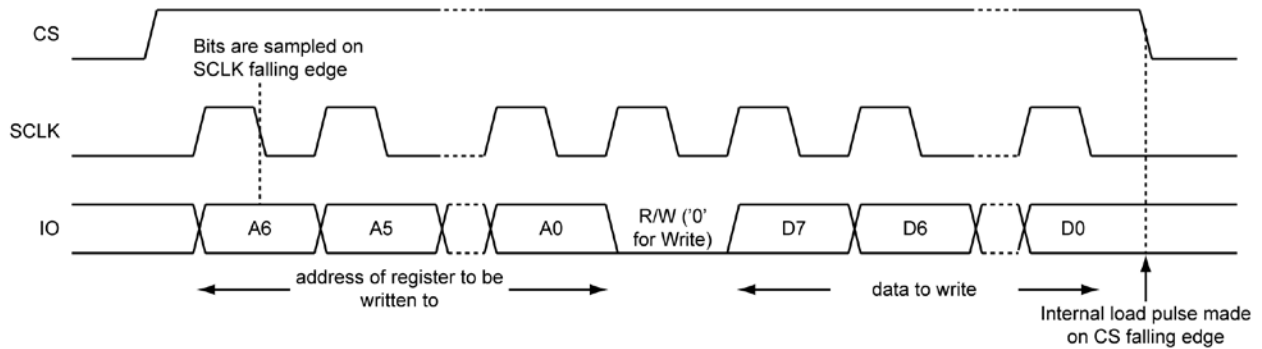

Figure 1. Writing a Byte into a Register

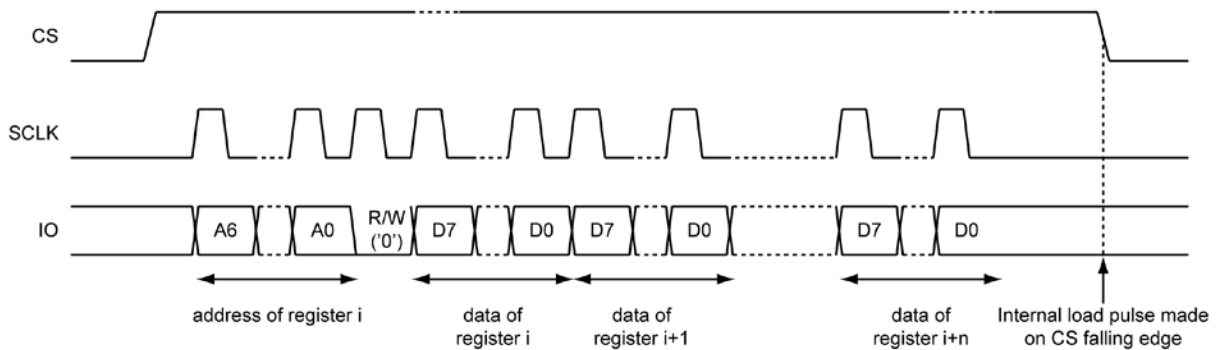

Figure 2. Writing Bytes into n+1 Registers at Consecutive Addresses Starting with Address i

Reading

Any number of registers with consecutive addresses, from one up to all 23, can be read.

Procedure:

- Bring CS active (high). IO is initially an input.
- Clock in a byte consisting of the address bits and the R/W bit. The first seven bits are the address (starting with MSB) of the register, or the first register if more than one, to be read. The eighth bit is the R/W bit, which is 1 as this is a read operation. After the R/W bit is clocked in (falling edge of SCLK), the next rising edge on SCLK will enable IO as an output for the duration of the transaction.

- Clock out 8 bits per register (one or more) to be read through IO, MSB first. Rising edges of SCLK bring each bit to IO. The user can then conveniently sample the bit at the next falling edge of SCLK.
- Bring CS low to end the transaction. IO reverts to being an input.

Figure 3 shows how to read one register. To read more registers at consecutive addresses, continue pulsing SCLK eight times for each register to be read before de-asserting CS.

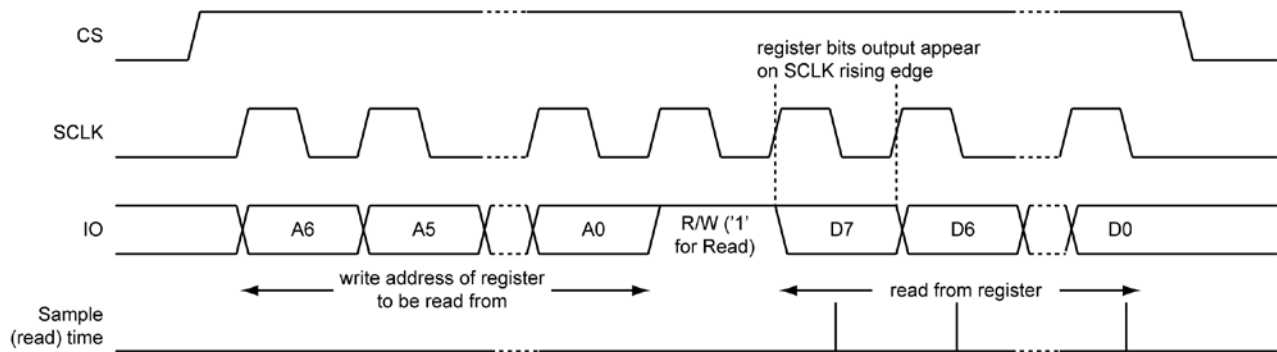

Figure 3. Reading a Byte from a Register

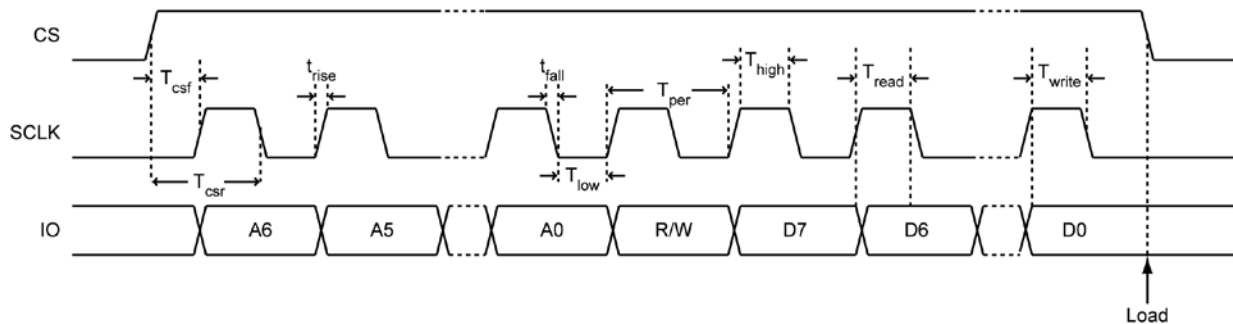

Figure 4. Definitions of Control Interface Timing Parameters

Control Interface Timing

Figure 4 and Table 2 give the timing specifications for the control interface.

When in Receive or Transmit mode (but not Power-down or Standby mode), an additional timing constraint applies: elapsed time between falling edges of CS must be a minimum of $2/f_c$, where f_c is the synthesizer’s comparison frequency (also called phase detector frequency). $f_c = f_{XCO}/M$,

$$f_c = \frac{f_{XCO}}{M}$$

$$\text{min time} = \frac{2M}{f_{XCO}}$$

where $M = M0$ when receiving or transmitting with VCO modulation, and $M = \max\{M0, M1\}$ when transmitting with divider modulation.

| Symbol | Parameter | Values | | | Units |
|-------------|---|--------|------|------|---------|
| | | Min. | Typ. | Max. | |
| T_{high} | Min. high time of SCLK | 20 | | | ns |
| T_{low} | Min. low time of SCLK | 20 | | | ns |
| t_{fall} | Fall time of SCLK | | | 1 | μ s |
| t_{rise} | Rise time of SCLK | | | 1 | μ s |
| T_{csr} | Time from rising edge of CS to falling edge of SCLK | 50 | | | ns |
| T_{cst} | Min. delay from rising edge of CS to rising edge of SCLK | 25 | | | ns |
| T_{write} | Min. delay from valid IO to falling edge of SCLK during a write operation | 20 | | | ns |
| T_{read} | Min. delay from rising edge of SCLK to valid IO during a read operation (assuming load capacitance of IO is 25pF) | 75 | | | ns |
| t_{POR} | Power on Reset time | | 4.6 | 9 | ms |

Table 1. Control Interface Timing

Power-on Reset

The power-on reset time (t_{POR}), given in Table 2, is defined as the time from application of supply voltage to completion of power on reset.

To determine when the chip has completed its power-on without waiting for the worst-case time (maximum t_{POR}), do the following:

- Write hex 03 (binary 00000011) to Register 0. This puts the chip in Standby mode.
- Read Register 0. If the value read is binary 00000011, then exit; power-on is complete. If not, go to previous step and repeat.

Because registers are initially in an unknown state after power-on (exception: Mode[1:0] initializes to 00), always enter a complete set of register values as the first transaction, and always enter only nonzero values for N and M.

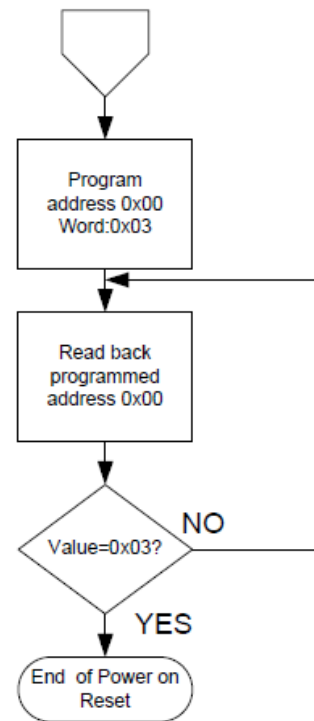

Figure 5. Power-On Programming Flowchart

Clock Generation

The MICRF507's crystal oscillator:

- Serves as the reference for the synthesizer that is the carrier and local oscillator source.
- Is divided down to clock the switched-capacitor IF filter.
- Is divided down to generate three other clocks: bit rate clock, bit synchronization clock, and modulator clock

Figure 6 shows the oscillator with its frequency-shifting capacitor bank (controlled by the register field XCOtune) and the frequency dividers that derive the latter three clocks from its output. This division occurs in two stages. First, the XCO output is divided by the 6-bit field Refclk_K, which has allowable values between 1 and 63. Then, for each of the three clocks, another field (BitSync_clkS, BitRate_ClkS, and ModClkS, respectively) selects the number of further divisions by 2. Complete relationships of field values and resultant frequencies are given below for each clock.

| Field Name | Number of bits | Location of bits | Description |
|--------------|----------------|--------------------|---|
| XCOtune | 5 | Reg9[4:0] | Crystal oscillator trimming. |
| RefClk_K | 6 | Reg7[5:0] | Reference clock divider. |
| BitRate_clkS | 3 | Reg6[0], Reg7[7:6] | Transmitter Bit rate clock setting. See Figure 9 and "Data Interface and Bit Synchronization" section for more details. |
| Mod_clkS | 3 | Reg6[6:4] | VCO Modulator clock setting, set the modulator clock to either 8x or 16x the bit rate clock. |
| BitSync_clkS | 3 | Reg6[3:1] | Receiver Bit Synchronization clock setting, always set bit synchronization clock to 16x the bit rate clock. See Figure 9 and "Data Interface and Bit Synchronization" section for more details. |

Table 3. Register Bit Fields for Clock Generation

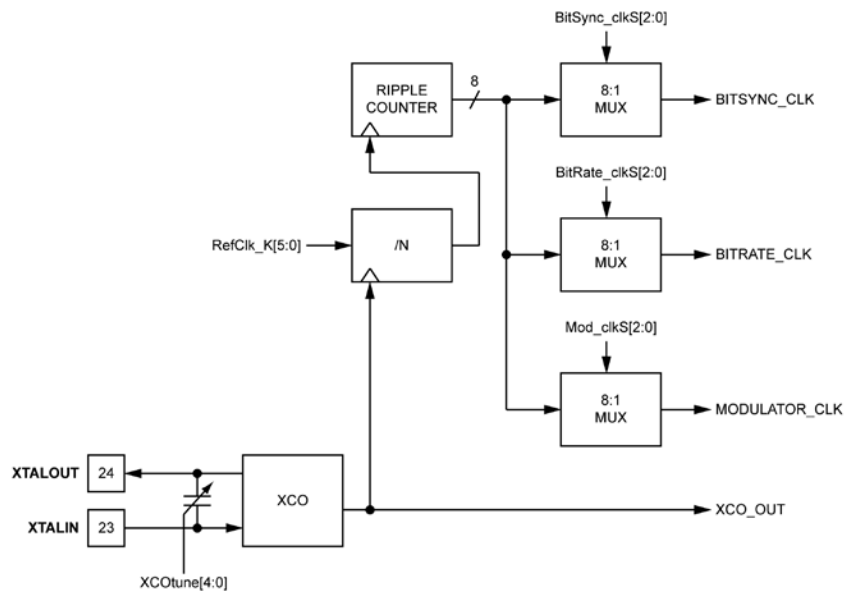

Figure 6. MICRF507 Clock Sources

Crystal Oscillator (XCO)

The crystal oscillator’s role as the synthesizer reference demands very good phase and frequency stability. As shown in Figure 7, the external components required for the oscillator are a crystal, connected between pins 23 and 24, and loading capacitors.

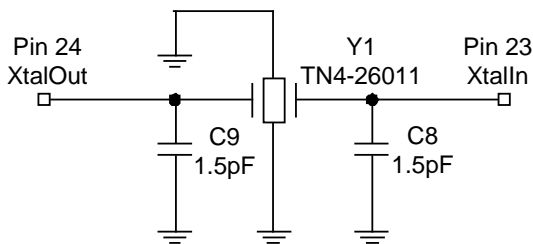

Figure 7. Crystal Oscillator Circuit

The load capacitance C_L seen between the crystal terminals is:

$$C_L = \frac{1}{\frac{1}{\frac{1}{C_8} + \frac{1}{C_9}} + C_{XCOTune} + C_{pin}}$$

Where $C_{XCOTune}$ is the capacitance of the internal adjustable capacitor bank, and C_{pin} is defined as the internal chip capacitance when XCOtune bits are all zeros, plus PCB stray capacitance across pins 23 and 24. The value of C_{pin} is about 6pF. The loading capacitor values required depend on the total C_L specified for the crystal for oscillation at the desired frequency.

It is possible to tune the crystal oscillator internally by giving the 5-bit register field XCOtune a non-zero value, which causes internal capacitors to be switched across the crystal. As this capacitance increases, frequency decreases. When XCOtune is set to its maximum value of 31, approximately 4.5pF additional capacitance is connected across the crystal pins.

The XCO tuning can be used to cancel crystal resonant frequency error, both initial and with temperature. It can be used in combination with the Frequency Error Estimator (FEE). See “FEE” section.

The crystal used is a TN4-26011 from Toyocom. Specification:

- Package TSX-10A,
- Nominal frequency 16.000000MHz
- Frequency tolerance ± 10 ppm
- Frequency stability ± 9 ppm, load capacitance 9pF
- Pulling sensitivity 15ppm/pF

To achieve 9pF load capacitance required to center TN4-26011 at 16MHz, set the external capacitors to 1.5pF and XCOtune=16_{dec}. Figure 8 shows the tuning range for two different capacitor values, 1.5pF and zero (external capacitors omitted). External capacitor values will strongly affect the tuning range. Using 1.5pF with the above crystal gives a tuning range that is approximately symmetrical about the center frequency.

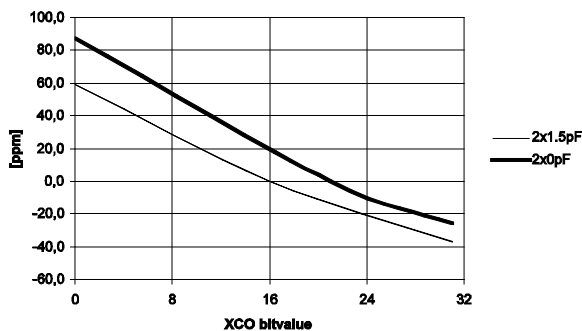

Figure 8. XCO Tuning with the XCOtune Field

The start-up time of the crystal oscillator, given in Table 4, is about a millisecond and increases with capacitance. When the MICRF507’s main mode is switched from Power down mode to Transmit mode via Standby mode, or to Receive mode via Standby mode, only the XCO is energized at first. Current consumption during this prestart period is approximately 280 μ A (the same as for Standby mode). After the XCO amplitude is sufficient to trigger the M-counter and produce two pulses at its output, the remaining circuits on the chip are powered on.

| XCOtune | Start-up Time (μ s) |
|---------|--------------------------|
| 0 | 590 |
| 1 | 590 |
| 2 | 700 |
| 4 | 700 |
| 8 | 810 |
| 16 | 1140 |
| 31 | 2050 |

Table 4. Typical Crystal Oscillator Start-up Time with C8 = C9 = 1.5pF

An external reference clock, when used instead of a crystal, should be applied to pin 24 (XTALOUT) with pin 23 (XTALIN) not connected. To maintain proper DC biasing within the chip, use AC-coupling between the external reference and the XTALOUT-pin.

BITSYNC_CLK (Receiver Bit Synchronization Clock)

The frequency of the bit synchronization clock $f_{\text{BITSYNC_CLK}}$, is a function of the crystal oscillator frequency f_{XCO} and the values of the register fields Refclk_K and BitSync_clkS:

$$f_{\text{BITSYNC_CLK}} = \frac{f_{\text{XCO}}}{\text{Refclk_K} \times 2^{(7-\text{BitSync_clkS})}}$$

The bit synchronizer uses a clock that needs to be programmed to 16 times the actual bit rate. As an example, a bit rate of 20kbps needs a bit synchronizer clock with frequency of 320kHz. Refer to Figure 9 and “Data Interface and Bit Synchronization” section for more details.

BITRATE_CLK (Transmitter Bit Rate Clock)

The frequency $f_{\text{BITRATE_CLK}}$ of BITRATE_CLK is a function of the crystal oscillator frequency f_{XCO} and the values of the register fields Refclk_K and BitRate_clkS:

$$f_{\text{BITRATE_CLK}} = \frac{f_{\text{XCO}}}{\text{Refclk_K} \times 2^{(7-\text{BitRate_clkS})}}$$

In transmit mode, when Sync_en = 1, BITRATE_CLK appears on the DATACLK pin. Its frequency is equal to the bit rate. Example; a bit rate of 20 kbit/sec requires an $f_{\text{BITRATE_CLK}}$ of 20kHz. Refer to Figure 9 and the “Data Interface and Bit Synchronization” subsection for more details.

MODULATOR_CLK (VCO Modulator Clock)

The frequency $f_{\text{MOD_CLK}}$ of MODULATOR_CLK is a function of the crystal oscillator frequency f_{XCO} and the values of the register fields Refclk_K and Mod_clkS:

$$f_{\text{MOD_CLK}} = \frac{f_{\text{XCO}}}{\text{Refclk_K} \times 2^{(7-\text{Mod_clkS})}}$$

The modulator clock is used if VCO modulation method is selected. Set the modulator clock frequency to either 8x or 16x the bit rate. See “VCO Modulation and the Modulator” subsection for more information.

| BitRate_clkS[2:0] BitSync_clkS[2:0] Mod_clkS[2:0] | Corresponding Clock Frequency (f_{XCO} is crystal frequency) |
|---|---|
| 000 | $f_{\text{XCO}}/(128 \times \text{RefClk_K})$ |
| 001 | $f_{\text{XCO}}/(64 \times \text{RefClk_K})$ |
| 010 | $f_{\text{XCO}}/(32 \times \text{RefClk_K})$ |
| 011 | $f_{\text{XCO}}/(16 \times \text{RefClk_K})$ |
| 100 | $f_{\text{XCO}}/(8 \times \text{RefClk_K})$ |
| 101 | $f_{\text{XCO}}/(4 \times \text{RefClk_K})$ |
| 110 | $f_{\text{XCO}}/(2 \times \text{RefClk_K})$ (*) |
| 111 | $f_{\text{XCO}}/\text{RefClk_K}$ (*) |

(*) Can not be used as *BitRate_clk*.

Table 5. Generation of Bitrate_clk, BitSync_clk and Mod_clk

Data Interface and Bit Synchronization

Transmitted and received data bits are coupled to the MICRF507 serially through the Data Interface. This Data Interface consists of the DATAIXO and DATACLK pins. This is a separate interface from the Control Interface (CS, IO, and SCLK), for which see Control (3-wire) Interface.

Figure 9 shows the data interface circuitry aboard the MICRF507. DATAIXO is an input during transmission, whereas during reception a driver is enabled and it becomes an output. DATACLK is always an output.

A rule that applies when using VCO modulation is: after commanding the MICRF507 to enter transmit mode, the microcontroller shall tri-state the driver connected to DATAIXO to leave that pin floating until the microcontroller begins sending data. See “Mode Transitions” section for more details.

The data interface can be programmed for synchronous and non-synchronous operation according to the setting of the Sync_en bit; see Table 7.

| Field Name | Number of bits | Location of bits | Description | Reference |
|------------|----------------|------------------|-----------------------|-----------|
| Sync_en | 1 | Reg0[3] | Synchronizer Mode bit | Table 7 |

Table 6. Register Bit Fields for Data Interface and Bit Synchronization

| Sync_en | State | Comments |
|---------|-----------------------------|---------------------------------------|
| 0 | RX: Bit synchronization off | Transparent reception of data |
| 0 | TX: DataClk pin off | Transparent transmission of data |
| 1 | RX: Bit synchronization on | Bit clock is generated by transceiver |
| 1 | TX: DataClk pin on | Bit clock is generated by transceiver |

Table 7. Synchronizer Mode Bit

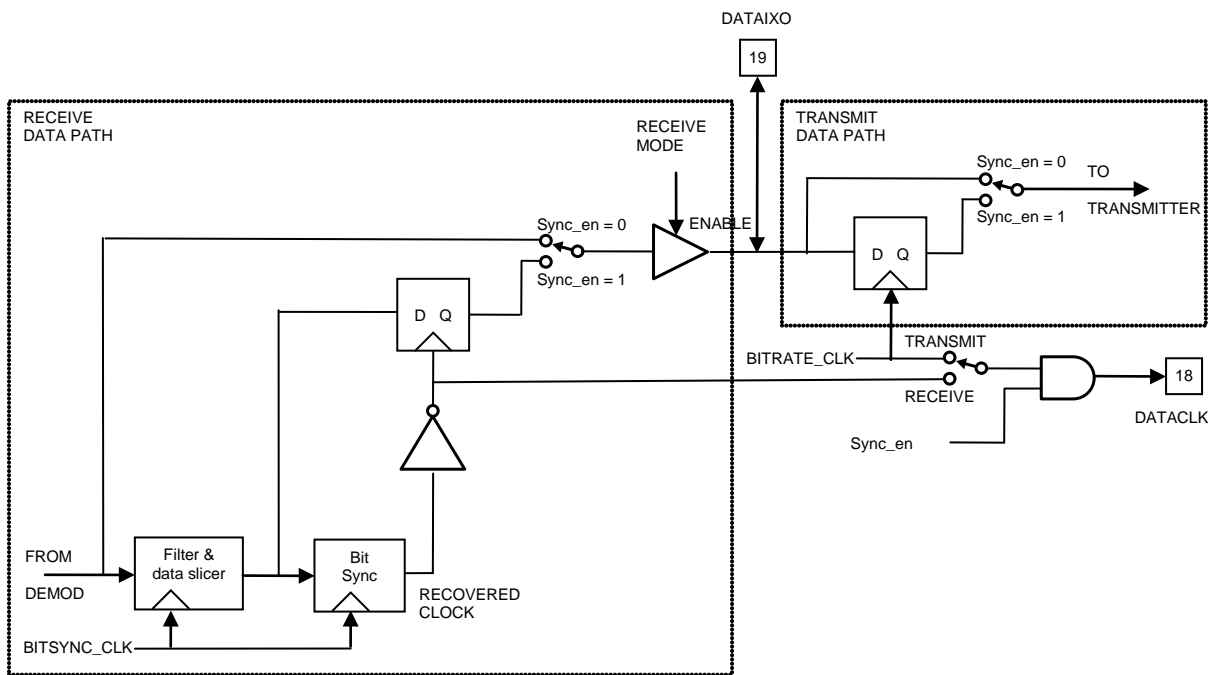

Figure 9. Data Interface and Synchronization

| Mode | Sync_en | DATACLK | | DATAIXO | |
|----------|---------|-----------|-------------------------------------|-----------|--|
| | | Direction | Signal | Direction | Signal/Function |
| Transmit | 0 | Output | 0 | Input | Modulates carrier directly (asynchronously) |
| | 1 | Output | BitRate clock | Input | Sampled at rising edge of BitRate clock; latched output modulates carrier |
| Receive | 0 | Output | 0 | Output | Raw output from demodulator |
| | 1 | Output | Clock recovered by bit synchronizer | Output | Filtered and latched demodulator output; transitions occur at rising edge of DATACLK |

Table 8. Synchronizer Mode and Data Interface

In sync mode (Sync_en bit set to 1), the transmitted bit stream is clocked with the precision of the MICRF507’s crystal oscillator, which relaxes timing accuracy requirements on the data source. During reception, the synchronizer ensures that transitions of DATAIXO occur only at rising edges of DATACLK, without edge jitter or internal glitches. Receiver sensitivity values given in the Electrical Characteristics table are measured with Sync_en = 1; with Sync_en = 0, as much as 3-6 dB of sensitivity could be lost.

Sync_en = 0

When Sync_en = 0, the input signal at DATAIXO modulates the transmitter directly during transmission and the output signal from DATAIXO is the raw demodulator output. DATACLK remains fixed at a logic low level during both transmission and reception.

Sync_en = 1

During transmission when Sync_en = 1 the data bit stream entering DATAIXO is buffered with a flip-flop strobed at the rising edge of BITRATE_CLK, and the output of the flip-flop modulates the transmitter. BITRATE_CLK is brought out at the DATACLK output. Figure 10 shows the relationship of DATACLK and DATAIXO transitions.

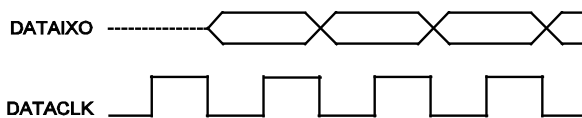

Figure 10. Data Interface in Transmit Mode

During reception, the bit synchronizer recovers the received signal’s clock. This recovered clock strobes a flip-flop that samples in mid-bit-period the demodulated and filtered bit stream. The DATACLK output brings out the

recovered clock. DATAIXO (an output during reception) brings out the synchronized data stream, which has its transitions at rising edges of DATACLK. See Figure 11.

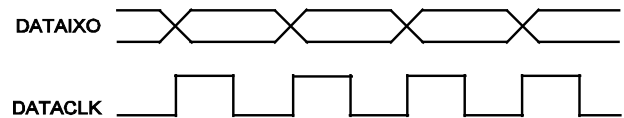

Figure 11. Data Interface in Receive Mode

By being in control of bit timing, the MICRF507 is effectively the “master.” For maximum timing margin, the microcontroller, as the “slave,” can present or sample (during transmit and receive, respectively) each new bit at the DATAIXO pin at falling edges of DATACLK.

Additional Considerations in the Use of Synchronizer (Sync_en = 1)

Two clock signals, BITRATE_CLK and BITSYNC_CLK, must be properly programmed when using the synchronizer. BITRATE_CLK, used in transmission, must be set to a frequency equal to the bit rate. BITSYNC_CLK, used in reception, must have a frequency 16 times the bit rate. These frequencies are controlled by the crystal oscillator frequency and the settings of register fields, as described in the “Clock Generation” section. Bit clocking of the incoming signal must agree with the receiver’s local clocking within ±2.5% (easily met with 100 PPM or better crystals). For example, if f_{BITSYNC_CLK} is 16x19.231kbps, the incoming bit rate can be between 0.975x19.231kbps to 1.025x19.231kbps.

All incoming messages must start with a 0101... preamble so that the synchronizer can acquire the incoming clock. A 24-bit preamble is typically used; a minimum of 22 bits is required.

Frequency Synthesizer

The MICRF507 frequency synthesizer is an integer-N phase-locked loop consisting of:

- a reference source, made of an M-divider clocked by the crystal oscillator
- a voltage controlled oscillator (VCO)
- a programmable frequency divider made of an N-divider, an A-divider, and a dual modulus prescaler
- a phase/frequency detector

The loop filter is external for flexibility and can be a simple passive circuit.

The phase/frequency detector compares the reference frequency (from the M-divider) with the VCO output fed through the programmable frequency divider. The charge pump output of the phase/frequency detector,

after filtering, controls the VCO, closing the loop and forcing the error between the reference frequency and the divided VCO frequency to zero.

The block diagram, Figure 12, shows the basic elements and arrangement of a PLL-based frequency synthesizer. The MICRF507 has a dual modulus prescaler for increased frequency resolution. In a dual modulus prescaler the main divider is split into two parts, the main part N and an additional divider A, where $A < N$. Both dividers are clocked from the output of the dual-modulus prescaler, but only the output of the N divider is fed into the phase detector. The prescaler will first divide by 16. Both N and A count down until A reaches zero, at which point the prescaler is switched to a division ratio 16+1. At this point, the divider N has completed A counts. Counting continues until N reaches zero, which is an additional N-A counts. At this point, the cycle repeats.

| Field Name | Number of bits | Location of bits | Description |
|------------|----------------|---------------------------|--|
| M0 | 12 | Reg13[3:0], Reg14[7:0] | M0 counter |
| A0 | 6 | Reg10[5:0] | A0 counter |
| N0 | 12 | Reg11[3:0], Reg12[7:0] | N0 counter |
| M1 | 12 | Reg18[3:0], Reg19[7:0] | M1 counter |
| A1 | 6 | Reg15[5:0] | A1 counter |
| N1 | 12 | Reg16[3:0], Reg17[7:0] | N1 counter |
| CP_HI | 1 | Reg2[7] | High charge pump current (1= 500 μ A, 0 = 125 μ A) |
| VCO_Freq | 2 | Reg3[1:0] | Frequency setting of VCO (see Table 11) |
| VCO_IB | 3 | Reg3[4:2] | VCO bias current setting (see Table 11) |
| LD_en | 1 | Reg1[2] | Lock detect function on/off |

Table 9. Register Bit Fields for Frequency Synthesizer

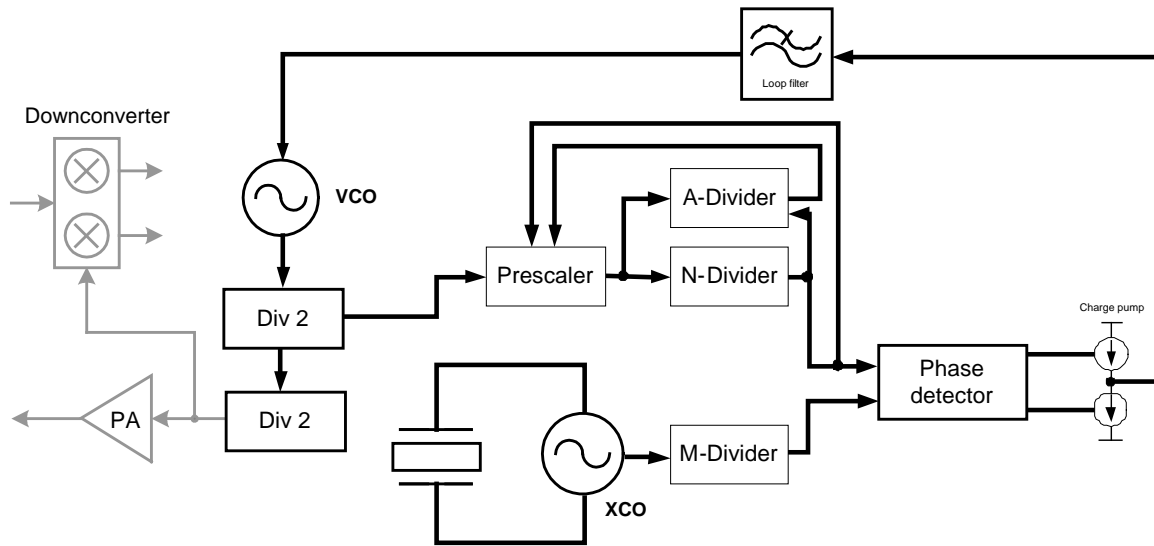

Figure 12. PLL Block Diagram

| A6...A0 | D7 | D6 | D5 | D4 | D3 | D2 | D1 | D0 |
|---------|------|------|------|------|-------|-------|------|------|
| 0001010 | - | - | A0_5 | A0_4 | A0_3 | A0_2 | A0_1 | A0_0 |
| 0001011 | - | - | - | - | N0_11 | N0_10 | N0_9 | N0_8 |
| 0001100 | N0_7 | N0_6 | N0_5 | N0_4 | N0_3 | N0_2 | N0_1 | N0_0 |
| 0001101 | - | - | - | - | M0_11 | M0_10 | M0_9 | M0_8 |
| 0001110 | M0_7 | M0_6 | M0_5 | M0_4 | M0_3 | M0_2 | M0_1 | M0_0 |
| 0001111 | - | - | A1_5 | A1_4 | A1_3 | A1_2 | A1_1 | A1_0 |
| 0010000 | - | - | - | - | N1_11 | N1_10 | N1_9 | N1_8 |
| 0010001 | N1_7 | N1_6 | N1_5 | N1_4 | N1_3 | N1_2 | N1_1 | N1_0 |
| 0010010 | - | - | - | - | M1_11 | M1_10 | M1_9 | M1_8 |
| 0010011 | M1_7 | M1_6 | M1_5 | M1_4 | M1_3 | M1_2 | M1_1 | M1_0 |

Table 10. Register Bit Fields for PLL

N, M, and A are numbers of length 12, 12 and 6 bits, respectively. The synthesizer's output frequency can be calculated from the following equation:

$$f_{PD} = \frac{f_{XCO}}{M} = \frac{f_{VCO}}{(16 \times N + A) \times 2} = \frac{f_{RF} \times 2}{(16 \times N + A)}$$

M ≠ 0

$$1 \leq A \leq 16$$

$$f_{RF} = f_{XCO} \frac{16 \times N + A}{2M}$$

where

f_{PD} : Phase detector comparison frequency

f_{XCO} : Crystal oscillator frequency

f_{VCO} : Voltage controlled oscillator frequency

f_{RF} : RF carrier frequency

The MICRF507 has two sets of register fields controlling the synthesizer's frequency multiplication ratio; A0/N0/M0 and A1/N1/M1. During transmission using divider modulation (see "Divider Modulation" section), bit values of '0' and '1' respectively select the 0 and 1 register field set. During reception and during transmission using VCO modulation, only the 0 set is used.

VCO

The VCO has no external components.

The three-bit field VCO_IB controls VCO bias current to optimize phase noise. The two bit field VCO_freq controls a capacitor bank which determines the VCO frequency range. These five bits are set according to the RF frequency as follows:

| RF Freq | VCO_IB2 | VCO_IB1 | VCO_IB0 | VCO_freq1 | VCO_freq0 |
|------------|---------|---------|---------|-----------|-----------|
| 470-482MHz | 1 | 0 | 1 | 0 | 1 |
| 482-497MHz | 1 | 0 | 0 | 1 | 0 |
| 497-510MHz | 0 | 1 | 1 | 1 | 1 |

Table 11. VCO Bit Setting

The tuning range, the RF frequency versus VCO tune voltage (varactor input, pin 29), depends on the VCO frequency setting as shown in as shown in Figure 13. When the tuning voltage is in the range from 0.9V to 1.4V, the VCO gain (as seen by the PLL) is at its maximum, approximately 64 to 70MHz/V. Note that the RF frequency is half of the PLL frequency. It is recommended that the VCO tune voltage stays in this range.

The input capacitance at the varactor pin must be taken into consideration when designing the PLL loop filter. This is most critical when designing a loop filter with high bandwidth, which gives relatively small component values. The input capacitance is approximately 6pF.

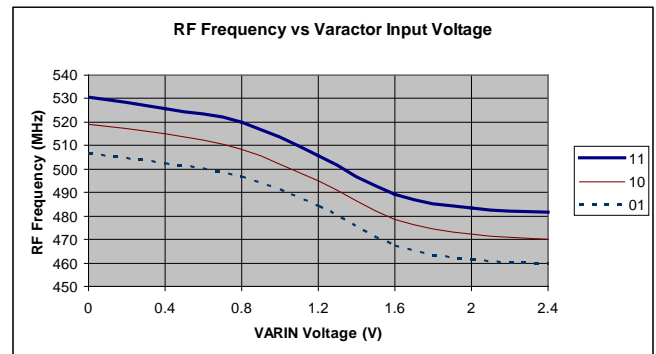

Figure 13. RF Frequency vs. Varactor Voltage and VCO_Freq bits (V_{DD} = 2.5V)

Charge Pump

The charge pump current can be set to either 125µA or 500µA by CP_HI ('1' → 500µA). This will affect the loop gain and, consequently, filter component values. For applications using high phase detector frequency and high PLL bandwidth, use 500µA charge pump current.

PLL Filter

The design of the PLL filter strongly affects the performance of the frequency synthesizer. Key parameters in PLL filter design are loop bandwidth, the modulation method (VCO modulation or divider modulation) and the bit rate. Filter design also affect the switching time (important when frequency hopping) and phase noise.

Divider modulation requires the PLL to lock on a new carrier frequency for every new data bit. As a rule of thumb, the PLL loop bandwidth should be at least twice as high as the bit rate. In such cases it is recommended to use a third order filter to suppress the phase detector frequency.

For VCO modulation, the PLL loop bandwidth should be less than 1/10 of the bit rate. If the loop bandwidth is high relative to the bit rate, the PLL will keep the VCO at a fixed frequency, preventing it from being modulated.

The recommended third-order loop filter (made with external components) is shown in Figure 14. When R2=0 and C3 is omitted, this reduces to a second-order loop filter.

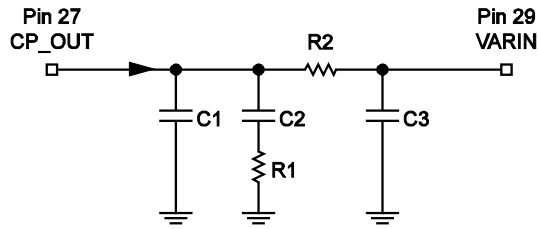

Figure 14. Second and Third Order Loop Filter

Table 12 shows three different loop filter designs, the first two for VCO modulation and the last one for modulation using the internal dividers. The component values are calculated with RF frequency = 490MHz, VCO gain = 67MHz/V as seen by the PLL, and desired phase margin = 56°. Other settings are shown in the table. The VARIN pin capacitance (pin 29) of 6pF can be neglected for the two filters with lowest bandwidth (which have R2=0 and relatively large values of C1). For other loop bandwidth and phase detector values, use the loop filter calculation tool in RF Testbench software available on Micrel’s website.

Lock Detect

A lock detector can be enabled by setting LD_en = 1. When pin LD is high, it indicates that the PLL is in lock.

After a control word is loaded LD will (typically) go low, then high again when the synthesizer has locked. LD also goes low initially when the PA (power amplifier) is turning on.

After the transceiver has been put into Receive or Transmit mode, or after the power amplifier has been turned on, a low-to-high transition at LD can serve as an indicator that the synthesizer frequency has stabilized.

| | Encoded Bit Rate (kbps) | PLL BW (kHz) | Charge Pump (µA) | Phase Detector Freq. (kHz) | C1 | C2 | R1 | R2 | C3 |
|---------|-------------------------|--------------|------------------|----------------------------|-------|-------|-------|------|------|
| VCO | >8 | 0.8 | 125 | 100 | 10nF | 100nF | 6.2kΩ | 0 | NC |
| VCO | >32 | 3.2 | 125 | 100 | 680pF | 6.8nF | 22kΩ | 0 | NC |
| Divider | <6.5 | 13 | 500 | 500 | 390pF | 8.2nF | 5kΩ | 68kΩ | 18pF |

Table 12. Loop Filter Component Values

Receiver

| Field Name | Number of bits | Location of bits | Description | Reference |
|------------|----------------|------------------|--|-----------|
| By_LNA | 1 | Reg0[7] | LNA bypass on/off | |
| PF_FC | 2 | Reg1[1:0] | Pre-filter corner frequency | Table 14 |
| SC_by | 1 | Reg2[6] | Bypass of switched capacitor filter on/off | |
| ScClk | 5 | Reg8[4:0] | Switched Cap clock divider | |
| RSSI_en | 1 | Reg1[3] | RSSI function on/off | |
| FEEC | 4 | Reg21[3:0] | FEE control bits | Table 15 |
| FEE | 8 | Reg22[7:0] | FEE value (read only) | |

Table 13. Register Bit Fields for Receiver

The receiver is a zero intermediate frequency (ZIF) type employing low-power, fully integrated low-pass filters.

A low noise amplifier (LNA) drives a quadrature mixer pair. The mixer outputs feed two identical signal channels. Each channel's signal path has a pre-amplifier, a third order Sallen-Key RC low-pass pre-filter, a six-pole switched-capacitor filter (which determines actual selectivity), and finally a limiter.

The limiter outputs then enter a demodulator which detects the relative phase of the baseband I and Q signals. If the I channel signal lags the Q channel, the FSK tone frequency lies above the LO frequency (data '1'). If the I channel leads the Q channel, then the FSK tone lies below the LO frequency (data '0'). The output of the demodulator is available on the DATAIXO pin; in either raw form or latched with the recovered clock according to the setting of Sync_en bit. An RSSI (receive signal strength indicator) circuit indicates the received signal level.

Front End

The MICRF507's low-noise amplifier boosts the incoming signal prior to frequency conversion in order to prevent mixer noise from degrading overall front-end noise performance. The LNA is a two-stage amplifier and has a nominal gain of approximately 23dB at 490MHz. The front end has a gain of about 31dB to34dB. The gain varies by 1-1.5dB over a 2.0V to 2.5V variation in power supply.

The LNA can be bypassed by setting bit LNA_by to '1'. This can be useful for very strong input signal levels. The front-end gain with the LNA bypassed is about 12dB. The mixers have about 10dB of gain at 490MHz. With appropriate setting of the OUTS field (register 2, bits D3 to D0), the differential outputs of the mixers can be made

available at pins lchOut and QchOut. The output impedance of each mixer is about 8kΩ.

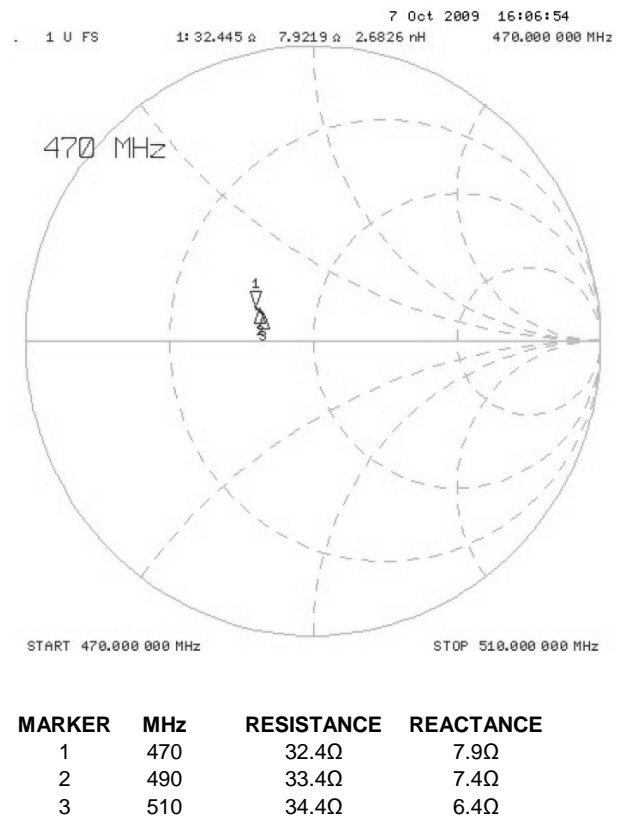

Figure 15. LNA Input Impedance

The front end's input impedance, with no matching network, is close to 50Ω as shown in Figure 15. This gives an input reflection coefficient of about -13dB. Although the receiver does not require a matching network to optimize the gain, a matching network is recommended for harmonic suppression during transmission and for improved selectivity in reception.

Sallen-Key Filters

Each IF channel includes a pre-amplifier and a pre-filter. The preamplifier has a gain of 22dB. The IF amplifier also removes DC offset. Gain varies by less than 0.5dB over a 2.0V to 2.5V variation in power supply. The pre-filter is implemented as a three-pole Sallen-Key low-pass filter. It protects the switched-capacitor filter that follows it from strong adjacent channel signals and also serves as an anti-aliasing filter. It is programmable to four different cut-off frequencies as shown in Table 14.

| PF_FC1 | PF_FC0 | Cutoff (3dB filter corner) |
|--------|--------|----------------------------|
| 0 | 0 | 100kHz |
| 0 | 1 | 150kHz |
| 1 | 0 | 230kHz |
| 1 | 1 | 340kHz |

Table 14. Pre-Filter Bit Field

Switched Capacitor Filter

The main IF channel filter is a switched-capacitor implementation of a six-pole elliptic low pass filter. This meets selectivity and dynamic range requirements with minimum total capacitance. The cut-off frequency of the switched-capacitor filter is adjustable by changing the clock frequency.

A 6-bit frequency divider, programmed by the ScClk[5:0] field, is clocked by the crystal oscillator. Its output, which is 20 times the filter's cutoff frequency, is then divided by 4 to generate the correct non-overlapping clock phases needed by the filter. The cut-off frequency of the filter is given by:

$$f_{CUT} = \frac{f_{XCO}}{40 \cdot ScClk}$$

- f_{CUT}: Filter cutoff frequency
- f_{XCO}: Crystal oscillator frequency
- ScClk: Switched capacitor filter clock, bits ScClk[4:0] (bit 0 has a mandatory value of '0').

For instance, for a crystal frequency of 16MHz and if the 6 bit divider divides the input frequency by 4, the cut-off frequency of the SC filter is 16MHz/(40 x 4) = 100kHz. A first-order RC low-pass filter removes clock frequency components from the signal at the switched-capacitor filter output.

The pre-filter and switched-capacitor filters in cascade must pass the full IF bandwidth of the received signal. In a zero-IF receiver such as the MICRF507 this bandwidth is as follows:

$$f_{BW} = f_{OFFSET} + f_{DEV} + \frac{r_b}{2}$$

where

- f_{BW}: Needed receiver bandwidth; f_{CUT} above should not be smaller than f_{BW} [Hz]
- f_{OFFSET}: Total frequency offset between receiver and transmitter [Hz]
- f_{DEV}: Single-sided frequency deviation [Hz]
- r_b: The bit rate in bits/sec

RSSI

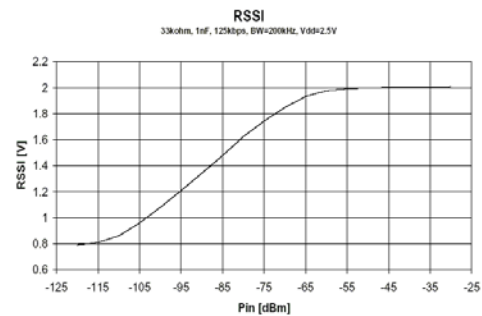

Figure 16. RSSI Voltage

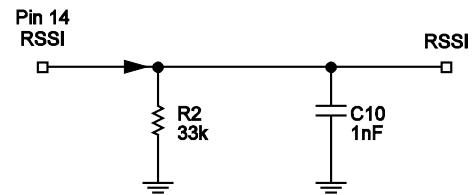

Figure 17. RSSI Network

Figure 16 shows a typical plot of the RSSI voltage as a function of input power. The RSSI termination network is shown in Figure 17. The RSSI has a dynamic range of about 50dB from about -110dBm to -60dBm input power.

When an RF signal is received, the RSSI output increases and can serve as a signal presence indicator. It could be used to wake up external circuitry that conserves battery life while in a sleep mode. Note that RSSI only functions in Receive mode.

Another use for RSSI is to determine that transmit power can be reduced in a system. If the RSSI detects a strong signal, the transmitter could be alerted to reduce its transmit power and so reduce current consumption.

FEE

The Frequency Error Estimator (FEE) counts pulses from inside the demodulator to measure the frequency offset between it's receive frequency and the transmitter's frequency. The maximum offset that FEE can correctly report a frequency difference is about ±20ppm. The output of the FEE can be used to tune the XCO frequency, both for production calibration and to compensate for crystal temperature drift and aging.

The FEE is enabled when FEEC[1:0] = 11, and is off when FEEC[1:0] = 00 (do not use other values). It has two counters. One counter determines the measurement period by generating a trigger every time it has counted up the number of bit periods selected by the setting of FEEC[3:2] as given in Table 15. A second counter accumulates the net tally of UP and DN pulses from the demodulator. For each incoming '1' bit, UP carries an average number of pulses that is twice the modulation index (β), and likewise for each incoming '0' bit and DN. The trigger transfers the contents of the second counter to the FEE register and clears it, after which it begins accumulating again.

| FEEC_1 | FEEC_0 | FEE Mode |
|--------|--------|---|
| 0 | 0 | Off |
| 0 | 1 | Do not use |
| 1 | 0 | Do not use |
| 1 | 1 | Counting UP and DN pulses. UP increments the counter, DN decrements it. |
| FEEC_3 | FEEC_2 | No. of bits used for the measurement |
| 0 | 0 | 8 |
| 0 | 1 | 16 |
| 1 | 0 | Do not use |
| 1 | 1 | Do not use |

Table 15. FEEC (Frequency Error Estimator Control) Bits

The result of the measurement, read from the FEE register at address 22 (16 hex, 0010110 binary), is actually an eight-bit two's complement signed number, which can have values from -128 to 127. Reading FEE gives the most recently transferred value. The raw FEE value, treated as an unsigned number ranging from 0 to 255, can be converted into a signed integer as follows:

If FEE < 128 then {FEE_{SIGNED} = FEE}
 Else {FEE_{SIGNED} = (FEE - 256)},

For a straightforward measurement of frequency offset, the incoming signal has to have an equal number of ones and zeros, such as a 1010... preamble. The frequency offset can then be calculated:

$$f_{\text{OFFSET}} = \frac{r_b}{4P} \text{FEE}_{\text{SIGNED}}$$

where FEE is the value read from the FEE register (treated as a signed number), P is the number of data bits over which the count is taken, and r_b is the bit rate. When f_{OFFSET} is zero, the transmitter and receiver are perfectly aligned. A positive f_{OFFSET} means that the received signal has a higher frequency than the carrier frequency to which the receiver is tuned. To compensate for this, the receiver's XCO frequency should be increased by reducing XCO_tune bits as detailed in the "Crystal Oscillator (XCO)" section.

Counting a larger number of symbols (higher P) improves the accuracy of the measurement. Beware, however, of overflow, which can cause the FEE value to jump from +127 to -128 after only one excessive count.

If the frequency offset is too large for the chosen P, then P must be reduced. P = 8 or P = 16 is safest.

XCOtune Procedure Example

A procedure such as the algorithm given below can be called during production (storing the calibrated XCO_tune value), at regular intervals, or implemented in the communication protocol when the frequency has changed. The MICRF507 measures the frequency offset between the demodulated signal and the LO, and a micro-controller programs the XCO_tune bits to tune the XCO so the LO frequency is equal to received carrier frequency.

Procedure description: A transmitter is assumed to be sending a 1010... pattern at the correct frequency and bit rate. The FEE is enabled (FEEC[1:0] = 11) and the number P of bit periods used in the measurement is 8 or 16. Only the sign of FEE is used.

Objective: The best XCO_tune value (giving the lowest IFEEI). The desired frequency of the receiver's PLL is midway between the "0" and "1" frequencies.

Local variables:

XCO_Present: (5-bit) holds current value in XCO_tune field

XCO_Step: (4-bit) holds amount by which XCO_tune will be incremented or decremented

XCO_Sign: (1 bit) has a value of either POS or NEG, determining respectively whether XCOtune is to be incremented or decremented (reducing XCOtune increases LO frequency)

XCO_tune_bits is a buffer, which is written to the XCOtune field when ProgramRFChip is called.

XCO TUNE PROCEDURE

Initialization:

```
XCO_Present = 16;
XCO_Step = 16;
XCO_Sign = NEG;
```

Registers properly set for reception;

LOOP:

```
XCO_Step = XCO_Step/2;
If (XCO_Sign == POS) then
  // If POS then increase LO frequency:
  {XCO_present = XCO_present - XCO_Step}
Else
  // If NEG then decrease LO frequency:
  {XCO_present = XCO_present + XCO_Step}
;
```

```
XCO_tune_bits = XCO_Present;
ProgramRFChip;
Wait for > P bit periods;
```

```
Read FEE;
If (FEE > 0?) then
  {XCO_Sign = POS}
else
  {XCO_Sign = NEG} // negative or 0
;
If (XCO_Step > 1) then
  {Branch to LOOP}
Else
  {If(XCO_Sign == POS) then
    {XCO_Present = XCO_Present - 1;
    Return (XCO_Present)}; \\ done
  }
;
```

Transmitter

Power Amplifier

The maximum output power of the power amplifier (PA) is approximately 10dBm with a 50Ω load. For maximum output power, the load seen by the PA must be resistive. Higher output power can be obtained by decreasing the load impedance, but this will conflict with impedance matching to the LNA.

The output power is programmable in seven levels by means of the PA[2:0] field, with approximately 2.5dB between steps; see Table 17. The power amplifier is turned off when PA[2:0] = 000. Otherwise the PA is on and output power increases with the value of the PA[2:0] field and is maximum when PA[2:0] = 111.

Setting PA_by=1 causes the PA to be bypassed and output power to drop by ~22dB. It is still possible to control the power with PA[2:0] bits.

The LC filter shown in Figure 18 reduces harmonic emission when placed between the ANT pin and antenna.

| Field Name | Number of bits | Location of bits | Description | Reference |
|------------|----------------|------------------|------------------------------|-----------|
| Modulation | 2 | Reg1[7:6] | Modulation selection | Table 18 |
| Mod_I | 5 | Reg4[4:0] | Modulator current setting | |
| Mod_A | 4 | Reg5[3:0] | Modulator attenuator setting | |
| Mod_F | 3 | Reg4[7:5] | Modulator filter setting | |
| PA | 3 | Reg0[6:4] | Power amplifier level | Table 17 |
| PA_by | 1 | Reg2[4] | Bypass of PA stage on/off | Table 17 |

Table 16. Register Bit Fields for Transmitter and VCO Modulation

| PA2 | PA1 | PA0 | State (approximate attenuation) |
|-------|---|-----|---------------------------------|
| 0 | 0 | 0 | PA off |
| 0 | 0 | 1 | 15dB attenuation |
| 0 | 1 | 0 | 12.5dB attenuation |
| 0 | 1 | 1 | 10dB attenuation |
| 1 | 0 | 0 | 7.5dB attenuation |
| 1 | 0 | 1 | 5dB attenuation |
| 1 | 1 | 0 | 2.5dB attenuation |
| 1 | 1 | 1 | Max output |
| PA_By | | | |
| 0 | Power Amplifier Enabled | | |
| 1 | Power Amplifier bypassed, approx 20dB reduced output power. | | |

Table 17. Register Bit Fields for Power Amplifier

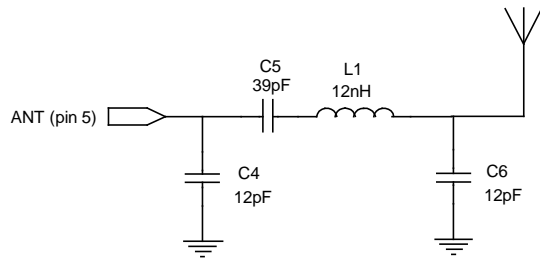

Figure 18. LC Filter

This filter is designed for the 490MHz band with 50Ω terminations. Component values may have to be tuned to compensate for layout parasitics.

Frequency Modulation

The MICRF507 supports two methods of FSK modulation, selected with the Modulation field as shown in Table 18: VCO modulation (enabled when Modulation1 is bit set to 0) and divider modulation (Modulation1 bit set to 1). The Modulation0 bit must always remain 0.

| Modulation1 | Modulation0 | State |
|-------------|-------------|----------------------------|
| 0 | 0 | Closed loop VCO-modulation |
| 0 | 1 | Not in use |
| 1 | 0 | Modulation by A,M and N |
| 1 | 1 | Not in use |

Table 18. Modulation Field

Bits from the microcontroller to be transmitted enter at the DATAIXO pin. See Table 19.

The modulation index β must be a minimum of 2. It is given by

$$\beta = 2 \frac{f_{DEV}}{r_b}$$

in which f_{DEV} is the single-sided deviation and r_b is the bit rate. Another constraint on f_{DEV} is

$$f_{DEV} \geq r_b + f_{OFFSET}$$

where f_{OFFSET} is the total frequency offset between the receiver and the transmitter:

The calculated f_{DEV} should be used to calculate the needed receiver bandwidth, see “Switched Capacitor Filter” section.

| | VCO Modulation | Frequency Divider Modulation |
|---|---|---|
| Set Modulation[1:0] to | 00 | 10 |
| Means of modulation | VCO modulation using modulator | Divider modulation by switching between A0/M0/NO and A1/M1/N1 |
| Register fields to set | Refclk_K, Mod_clkS, Mod_I, Mod_A, Mod_F | A0, M0, N0, A1, M1, N1 |
| PLL bandwidth required | Lower than 1/10 of bit rate | Higher than 2x bit rate |
| Bitstream constraints | DC balance required | None |
| Instantaneous frequency waveform (spectrum) determined by | Register fields affecting modulator | PLL transient response |

Table 19. Modulation Modes

Divider Modulation

When Modulation[1:0] = 10, two sets of divider values need to be programmed. The divider values stored in the M0, N0, and A0 registers are selected to transmit a '0' and the M1, N1, and A1 registers are selected to transmit a '1'.

$$f_{RF0} = f_{XCO} \frac{16 \times N0 + A0}{2M0}$$

$$f_{RF1} = f_{XCO} \frac{16 \times N1 + A1}{2M1}$$

The carrier frequency that a receiver must be set to in order to receive the above transmitted signal is:

$$f_{RF} = \frac{f_{RF0} + f_{RF1}}{2}$$

and the single-sided deviation is:

$$f_{DEV} = \frac{f_{RF1} - f_{RF0}}{2}$$

The PLL must lock to a new frequency upon every transition in the transmitted bitstream and therefore, needs a high bandwidth, at least twice the bit rate.

VCO Modulation and the Modulator

VCO Modulation is selected when Modulation[1:0] = 00. The modulator generates a waveform with programmable amplitude and shape. This waveform is fed into a modulation varactor in the VCO, which performs the desired frequency modulation. The synthesizer operates with A=A0, M=M0, and N=N0.

To create the modulating waveform the modulator charges and discharges a capacitor, controlled by a modulator clock. As shown in Figure 19, each transition of the waveform takes four periods of the modulator clock. Charge/discharge current, and therefore slope, varies so

as to "round" the waveform and reduce the transmission spectral width.

The amplitude of the modulating waveform, and therefore frequency deviation, is determined by the modulation clock frequency (controlled by the crystal oscillator frequency and the register fields Refclk_K, and Mod_ClkS), the charge/discharge current (controlled by the register field Mod_I), and the setting of an attenuator (controlled by the register field Mod_A). The effects of these factors are explained and quantified below. A filter is provided to optimize transmit bandwidth, the proper setting of which is also explained below.

The synthesizer is a negative feedback loop that suppresses perturbations inside the loop (including the modulating varactor control voltage) below its bandwidth. The PLL will not allow modulation unless its transient response is slower than the bitstream pulses. Frequency deviation is a high-pass response to modulation. This means that when VCO modulation is used, the loop bandwidth must be less than the lowest baseband spectral component of the bitstream. It also means that the bitstream must be DC-free (have an equal number of ones and zeros). See "DC Balanced Line Coding" section.

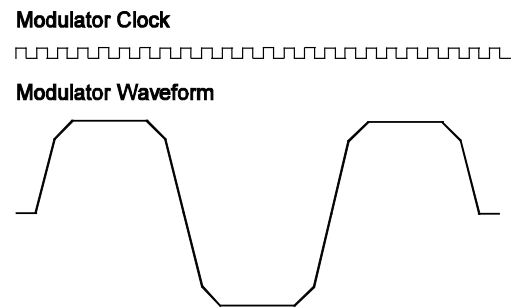

Figure 19. Modulator Waveform and Clock

Frequency Deviation under VCO Modulation

Three factors determine the deviation at which the data stream is modulated: modulator clock frequency, capacitor charge/discharge current, and modulator attenuator setting. After each is presented in turn, the complete formula for deviation is given.

The *modulator clock frequency* is determined by the crystal oscillator frequency and the settings of the Refclk_K and Mod_clkS fields:

$$f_{\text{MOD_CLK}} = \frac{f_{\text{XCO}}}{\text{Refclk_K} \times 2^{(7-\text{Mod_clkS})}}$$

Set the modulator clock frequency to either 8x or 16x the frequency deviation rate.

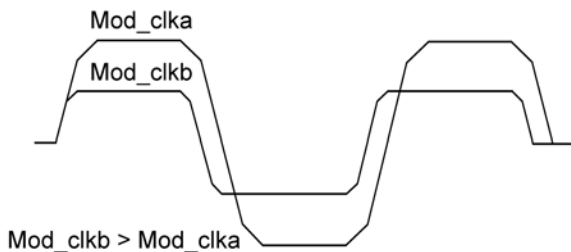

Figure 20. Two Different Modulator Clock Settings

Having $f_{\text{MOD_CLK}}$ set at 8 times the bit rate corresponds to a baseband data signal filtered in a Gaussian filter with a bandwidth-period product (BT) of 1. When BT is increased, the waveform will be less filtered. Figure 20 shows two waveforms with BT=1 (the minimum, with $f_{\text{MOD_CLK}}$ at 8 times the bitrate) and BT=2 (with $f_{\text{MOD_CLK}}$ at 16 times the bit rate). Changing BT changes the charge-and discharge times and therefore the frequency deviation, as seen in Figure 20.

The *capacitor charge/discharge current*, set with the Mod_I field, affects deviation, as shown in Figure 21, where $\text{Mod_Ia} > \text{Mod_Ib}$. Higher current will give a higher frequency deviation and vice versa. The effect of modulator clock and Mod_I is as follows:

$$f_{\text{DEV}} \propto \frac{\text{Mod_I}}{f_{\text{MOD_CLK}}}$$

To avoid saturation in the modulator, it is important not to exceed maximum Mod_I. Maximum Mod_I for a given $f_{\text{MOD_CLK}}$ is given by:

$$\text{Mod_I}_{\text{MAX}} = \text{INT}(f_{\text{MOD_CLK}} \cdot 28 \times 10^{-6}) - 1$$

where INT() returns the integer part of the argument.

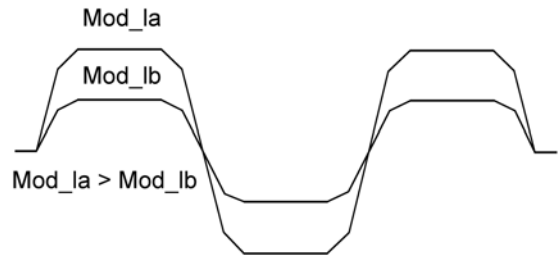

Figure 21. Two Different Modulator Current Settings

A third factor determining deviation is the *modulator attenuator*, controlled by the Mod_A field. The attenuator is used when the bit rate is small and/or the BT is small, which gives a relatively slow modulator clock and therefore long rise- and fall times, leading in turn to large frequency deviations unless the signal is attenuated. Additionally, the attenuator will improve the resolution in the modulator.

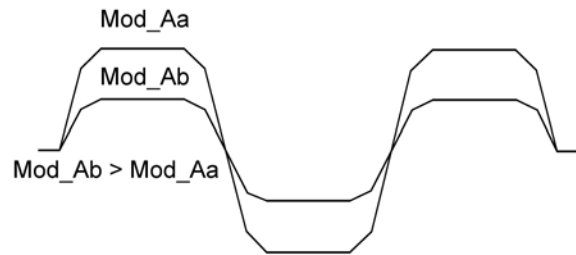

Figure 22. Two Different Modulator Attenuator Settings

The effect of the attenuator is given by:

$$f_{\text{DEV}} \propto \frac{1}{1 + \text{Mod_A}}$$

Figure 22 shows two waveforms with different attenuator setting: $Mod_Aa < Mod_Ab$. If Mod_A is increased, the frequency deviation is lowered and vice versa.

The resulting frequency deviation in terms of the parameters discussed above is given in the following equations:

$$f_{MOD_CLK} = \frac{f_{XCO}}{Refclk_K \times 2^{(7-Mod_clkS)}}$$

$$f_{DEV} = \frac{Mod_I}{f_{MOD_CLK}} \times \frac{1}{1+Mod_A} \times (C_1 + C_2 \times f_{RF})$$

where:

- f_{DEV} : Single sided frequency deviation [Hz]
- f_{XCO} : Crystal oscillator frequency [Hz]
- f_{RF} : Center frequency [Hz]
- Refclk_K: 6 bit divider, values between 1 and 63
- Mod_clkS: Modulator clock setting, values between 0 and 7
- f_{MOD_CLK} : Modulator clock frequency, derived from the crystal frequency, Refclk_K and Mod_clkS
- Mod_I: Modulator current setting, values between 0 and 31
- Mod_A: Modulator attenuator setting, values between 0 and 15
- C_1 : -2.72×10^{10}
- C_2 : 85.2

Note that the constants C_1 and C_2 are empirically derived. Actual frequency deviation may differ by a few percent.

Modulator Filter

To reduce the high-frequency components in the generated waveform, a filter with programmable cut-off frequency can be enabled. This is done using $Mod_F[2:0]$, bit 0 being LSB. The Mod_F field should be set according to the formula:

$$Mod_F = \frac{150 \times 10^3 \text{ bps}}{r_b}$$

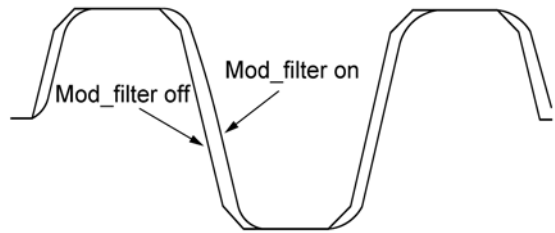

Figure 23. Modulator Waveform with and without Filtering

in which r_b is the bit rate in bits/sec. $Mod_F=0$ disables the modulator filter and $Mod_F=7$ provides the most filtering. Figure 23 shows a waveform with and without the filter.

The modulator filter will not influence the frequency deviation as long as the programmed cut-off frequency is above the actual bit rate.

System Modes and Initialization

Start-up and Initialization

After supply voltage is applied to the MICRF507, a power on reset period elapses during which it should be considered to be in an unknown state. The microcontroller should wait until power on reset is completed. See “Power-On Reset” subsection within the “Control (3-wire) Interface” section. After power-on is completed, all 22 writeable registers must be correctly initialized before operation of the MICRF507. Write only non-zero values to the M0, N0, M1, and N1 fields.

Modes of Operation

| Mode1 | Mode0 | State | Comments |
|-------|-------|------------|---------------------------------|
| 0 | 0 | Power down | Keeps register configuration |
| 0 | 1 | Standby | Only crystal oscillator running |
| 1 | 0 | Receive | Full receive |
| 1 | 1 | Transmit | Full transmit except PA state |

Table 20. Main Mode Bits

Mode Transitions

To go from power down mode to either receive or transmit mode, the MICRF507 needs to go through the standby mode first. This is to ensure that the crystal oscillator starts up correctly. Once the crystal oscillator settles, the MICRF507 can go to receive or transmit mode.

When the mode has been changed to Transmit or Receive, or when the power amplifier has been enabled, the synthesizer must be allowed to stabilize. See “Lock Detect” section.

When using VCO modulation; after MICRF507 has been put in transmit mode, the microcontroller will tri-state the driver connected to DATAIXO pin to leave that pin floating until the microcontroller begins sending data. This is because in transmit mode, the modulator is disabled while the DATAIXO pin is floating (a weak voltage divider sets its level at $V_{dd}/2$) in order to prevent a performance-degrading transient when message transmission begins.

Below, “write to registers” means writing a complete control word, or writing just to registers that need to change.

Transition to transmit mode:

- Write to registers, setting transmit mode, and other changes as needed; set/keep PA off (to reduce spurious emissions). This makes DATAIXO an input.
- Write to registers setting PA on (this requires updating Register 0 only).
- Wait for LD.
- Enable the microcontroller’s pin as an output driving DATAIXO and begin sending the transmit bitstream.
- After the last bit is transmitted return the microcontroller’s pin to being an input.

Transition to receive mode:

- Have the microcontroller’s DATAIXO driver disabled.
- Write to registers setting receive mode and other changes as needed.
- Wait for LD. Or, if desired, commence checking the received bitstream for a valid message without waiting.

| Field Name | Number of bits | Location of bits | Description | Reference |
|------------|----------------|------------------|---------------------|-----------|
| Mode | 2 | Reg0[2:1] | Main mode selection | Table 20 |
| OUTS | 4 | Reg2[3:0] | Test pins output | Table 28 |

Table 21. Register Bit Fields for System Functions

Message Coding and Formatting

DC Balanced Line Coding

Line coding, diagrammed in Figure 24, is used when a communication channel imposes constraints on bit sequences. An encoding stage that ensures DC balance (equal numbers of '1' and '0' bits and no long consecutive runs of either) in the encoded bit stream allows the use of VCO modulation without restrictions on the message bit stream. Of the coding schemes which meet this need, Manchester encoding and 3B4B are among the most commonly used. Programming and performance of the MICRF507 are based on the encoded bit rate.

In Manchester encoding, each message bit maps to a word made of two encoded bits as shown in Table 22. The encoded bit rate is twice the message bit rate so the encoding overhead is 100%. When selecting PLL loop filter it is important to note that frequency content of the encoded bit stream extends down to one-fourth of the encoded bit rate. That is the case of a 0101... message bit sequence, which results in a 100110011001... encoded bit sequence.

| Data | Word |
|------|------|
| "0" | "10" |
| "1" | "01" |

Table 22. Manchester Encoding

Another encoding method, which is much more efficient than Manchester coding, is 3B4B, where three message data bits are encoded into a four-line-bit word. The encoded bit rate is three-quarter times the message bit rate. For perfect DC balance, a four bit word would have to have two '1' line bits and two '0' line bits. Only six such words are possible. Special steps are therefore needed to deal with the remaining two encodings: whenever 000 and 111 data appear, toggle a flag that remembers whether the last encoded word was taken from the "Word A" column and select the respective word from the other column shown in Table 23.

| Data | Word A | Word B |
|------|--------|--------|
| 000 | 1011 | 0100 |
| 001 | 1100 | |
| 010 | 0011 | |
| 011 | 1010 | |
| 100 | 0101 | |
| 101 | 1001 | |
| 110 | 0110 | |
| 111 | 1101 | 0010 |

Table 23. 3B4B Encoding

| Data bits | Encoded words | Comments |
|------------------------|-----------------------------|--|
| 000 000 000 000 000 | 1011 0100 1011 0100 1011 | A Flag indicates if "Word A" has been used |
| 111 111 010 110 000 | 1101 0010 0011 0110 1011 | A Flag indicates if "Word A" has been used |

Table 24. Example of 3B4B Encoding

Message Formatting: Preamble

Messages are typically preceded by a header consisting of 24 bits in an alternating pattern: 0101... Such a header can permit the following actions by the receiver prior to the arrival of information-carrying bits:

- Reading of RSSI
- Bit synchronizer lock-up
- Using the FEE to null out frequency offset

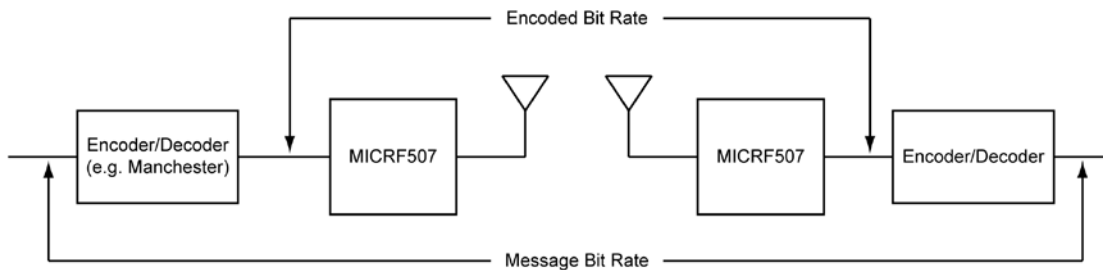
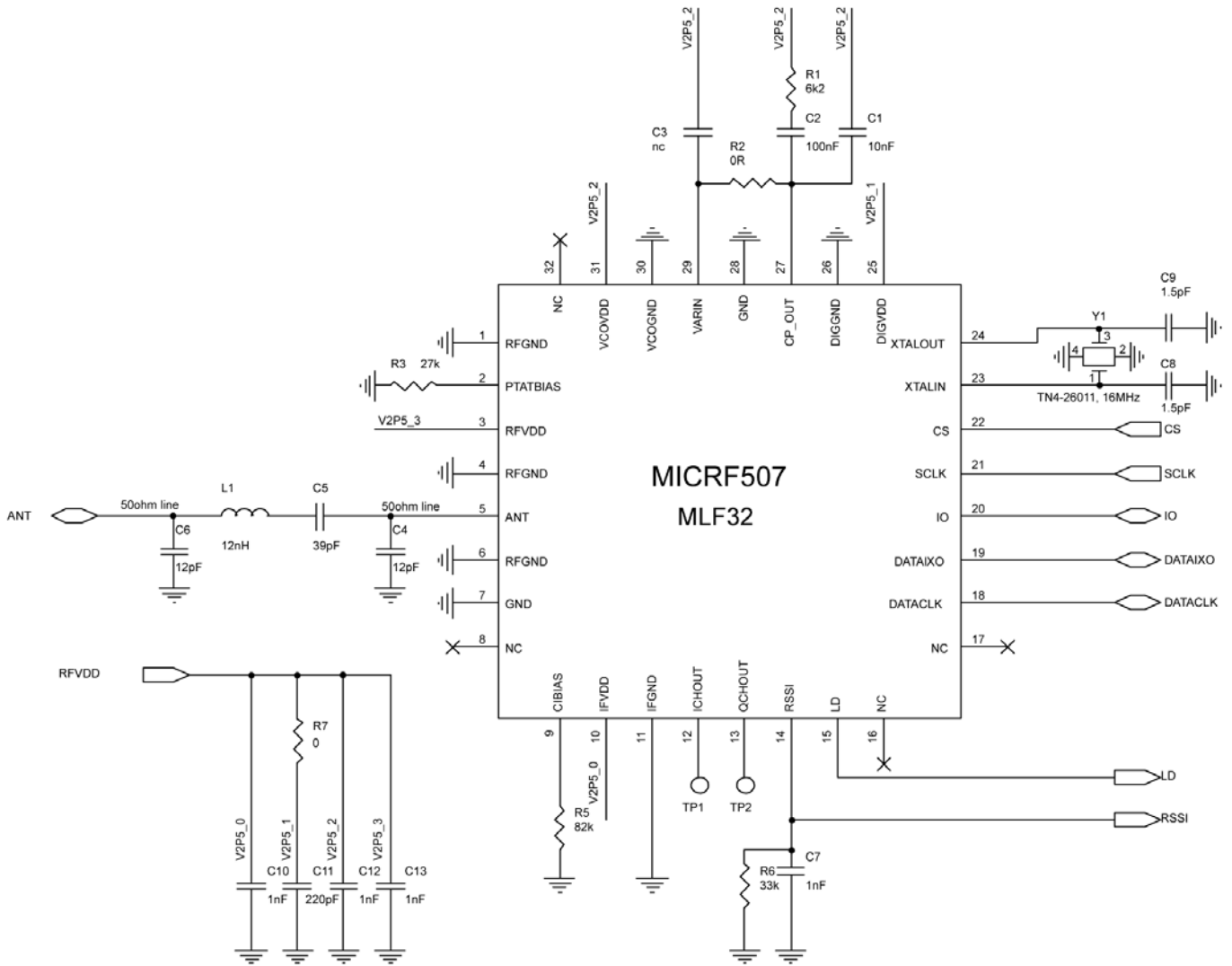

Figure 24. Link Architecture with Encoding

Typical Application



Bill of Materials

| Item | Part Number | Manufacturer | Description | Qty. |
|-----------|---------------------------------|-------------------------------------|---|----------|
| C1 | GRM188R71C103K | Murata ⁽⁶⁾ | 0.01 μ F, 16V Capacitor, X7R \pm 10%, Size 0603 | 1 |
| C2 | GRM219R71C104K | Murata | 0.1 μ F, 16V Capacitor, X7R \pm 10%, Size 0805 | 1 |
| C3 | | | No Connect | 0 |
| C4 | GRM1885C1H120J | Murata | 12pF, 50V Capacitor, COG \pm 5%, Size 0603 | 1 |
| C5 | GRM1885C1H390J | Murata | 39pF, 50V Capacitor, COG \pm 5%, Size 0603 | 1 |
| C6 | GRM1885C1H120J | Murata | 12pF, 50V Capacitor, COG \pm 5%, Size 0603 | 1 |
| C7 | GRM155R61A102K | Murata | Optional 1000pF | 1 |
| C8, C9 | GRM1555C1H1R5C | Murata | 1.5pF, 50V Capacitor, COG \pm 0.25pF, Size 0402 | 2 |
| C10 | GRM155R61A102K | Murata | 1000pF, 10V Capacitor, X5R \pm 10%, Size 0402 | 1 |
| C11 | GRM155R71H221K | Murata | 220pF, 50V Capacitor, X7R \pm 10%, Size 0402 | 1 |
| C12, C13 | GRM155R61A102K | Murata | 1000pF, 10V Capacitor, X5R \pm 10%, Size 0402 | 2 |
| R1 | CRCW04026200RJK | Vishay ⁽⁷⁾ | 6.2k Resistor, \pm 5%, Size 0402 | 1 |
| R2 | CRCW04020RJK | Vishay | 0 Ω Resistor, \pm 5%, Size 0402 | 1 |
| R3 | CRCW040227KJK | Vishay | 27k Resistor, \pm 5%, Size 0402 | 1 |
| R5 | CRCW040282KJK | Vishay | 82k Resistor, \pm 5%, Size 0402 | 1 |
| R6 | CRCW040233KJK | Vishay | 33K Resistor, \pm 5%, Size 0402 | 1 |
| R7 | CRCW04020RJK | Vishay | 0 Ω Resistor, \pm 5% Size 0402 | 1 |
| L1 | 0603CS-12NXJB | Coilcraft ⁽⁸⁾ | 12nH, \pm 5%, Size 0603 | 1 |
| Y1 | TSX-10A16.0000MHz: TN4-26011 | Toyocom ⁽⁹⁾ | 16MHz, 9pF, 10/10ppm | 1 |
| U1 | MICRF507 | Micrel, Inc. ⁽¹⁰⁾ | 470MHz to 510MHz Low-Power FSK Transceiver with +10dBm Power Amplifier | 1 |

Notes:

6. Murata: www.murata.com
7. Vishay: www.vishay.com
8. Coilcraft: www.coilcraft.com
9. Toyocom: www.epsontoyocom.co.jp/english
10. **Micrel, Inc.:** www.micrel.com

Layout Considerations

To ensure the best RF performance, a carefully planned layout is essential. Grounding, RF path geometry, supply routing, and layer definition all play a role in an optimal design. These are discussed below, and a recommended layout can be found on the Micrel website at: www.micrel.com.

Layer Definition

A typical MICRF507 PCB design consists of four layers, with the following stack-up:

Layer1 – Component and RF routing

Layer2 – Ground

Layer3 – VDD Routing

Layer 4 – Non-RF Routing

While not the only acceptable definition, this example provides a good foundation for the general techniques discussed below.

Grounding

Design the layout to provide the shortest possible return path for signals and noise sources. Place ground vias close to all critical items such as ground pins on the RF IC, decoupling capacitors, and matching components.

RF Traces

The ANT pin impedance is approximately 50Ω. To minimize reflection due to impedance mismatch, RF traces should be a controlled impedance of 50Ω as well. Refer to the Micrel Development Board layout, or a transmission line impedance calculator to verify a specific geometry's characteristic impedance.

Supply Routing

The radio system is sensitive to supply noise and signals coupled from one section to another. Routing the supply lines on an internal layer (below the ground layer) separates them from potential noise sources such as the reference oscillator, PA, charge pump, etc. Route supplies separately and place bypass capacitors as close as possible to the associated pin.

PLL Loop Filter

Place loop filter components close to each other and near pins 27 and 29. Connection of the loop filter to VDD should occur very close to VCOVDD, pin 31. Avoid routing potentially noisy busses or traces near the loop filter.

Overview of Programming Bits

| Address Field | Data Field | | | | | | | |
|---------------|------------------------|--------------------|----------------------|--------------------|-----------------|-----------------|-------------------|-----------------|
| | D7 | D6 | D5 | D4 | D3 | D2 | D1 | D0 |
| 0000000 | LNA_by | PA2 | PA1 | PA0 | Sync_en | Mode1 | Mode0 | Load_en |
| 0000001 | Modulation1 | Modulation0 | OL_opamp_en ("0") | PA_LDc_en ("0") | RSSI_en | LD_en | PF_FC1 | PF_FC0 |
| 0000010 | CP_HI | SC_by | VCO_by ("0") | PA_by | OUTS3 | OUTS2 | OUTS1 | OUTS0 |
| 0000011 | IFBias_s ("1") | IFA_HG ("1") | VCO_BIAS_s ("0") | VCO_IB2 | VCO_IB1 | VCO_IB0 | VCO_freq 1 | VCO_freq0 |
| 0000100 | Mod_F2 | Mod_F1 | Mod_F0 | Mod_I4 | Mod_I3 | Mod_I2 | Mod_I1 | Mod_I0 |
| 0000101 | - | - | Mod_FHG ("0") | Mod_shape ("1") | Mod_A3 | Mod_A2 | Mod_A1 | Mod_A0 |
| 0000110 | - | Mod_clkS2 | Mod_clkS1 | Mod_clkS0 | BitSync_clkS2 | BitSync_clkS1 | BitSync_clk S0 | BitRate_clkS2 |
| 0000111 | BitRate_clkS1 | BitRate_clkS0 | RefClk_K5 | RefClk_K4 | RefClk_K3 | RefClk_K2 | RefClk_K1 | RefClk_K0 |
| 0001000 | SC_HI ("1") | ScClk_X2 ("1") | ScSW_en ("0") | ScClk4 | ScClk3 | ScClk2 | ScClk1 | ScClk0 |
| 0001001 | PrescalMode_s ("0") | Prescal_s ("0") | XCOAR_en ("1") | XCOtune4 | XCOtune3 | XCOtune2 | XCOtune1 | XCOtune0 |
| 0001010 | - | - | A0_5 | A0_4 | A0_3 | A0_2 | A0_1 | A0_0 |
| 0001011 | - | - | - | - | N0_11 | N0_10 | N0_9 | N0_8 |
| 0001100 | N0_7 | N0_6 | N0_5 | N0_4 | N0_3 | N0_2 | N0_1 | N0_0 |
| 0001101 | - | - | - | - | M0_11 | M0_10 | M0_9 | M0_8 |
| 0001110 | M0_7 | M0_6 | M0_5 | M0_4 | M0_3 | M0_2 | M0_1 | M0_0 |
| 0001111 | - | - | A1_5 | A1_4 | A1_3 | A1_2 | A1_1 | A1_0 |
| 0010000 | - | - | - | - | N1_11 | N1_10 | N1_9 | N1_8 |
| 0010001 | N1_7 | N1_6 | N1_5 | N1_4 | N1_3 | N1_2 | N1_1 | N1_0 |
| 0010010 | - | - | - | - | M1_11 | M1_10 | M1_9 | M1_8 |
| 0010011 | M1_7 | M1_6 | M1_5 | M1_4 | M1_3 | M1_2 | M1_1 | M1_0 |
| 0010100 | Div2_HI ("1") | LO_IB1 ("0") | LO_IB0 ("1") | PA_IB4 ("1") | PA_IB3 ("0") | PA_IB2 ("1") | PA_IB1 ("0") | PA_IB0 ("1") |
| 0010101 | - | - | - | - | FEEC_3 | FEEC_2 | FEEC_1 | FEEC_0 |
| 0010110 | FEE_7 | FEE_6 | FEE_5 | FEE_4 | FEE_3 | FEE_2 | FEE_1 | FEE_0 |

Table 25. Overview of Register Bits

Detailed Description of Programming Bits

| ADR # | BIT # | Name | Description | Comments |
|---------|-------|-------------|---|--------------------|
| 0000000 | 7 | By_LNA | LNA bypass on/off | |
| | 6 | PA2 | Power amplifier level, 3.bit | Reference Table 17 |
| | 5 | PA1 | Power amplifier level, 2.bit | Reference Table 17 |
| | 4 | PA0 | Power amplifier level, 1.bit | Reference Table 17 |
| | 3 | Sync_en | Synchronizer Mode bit | Reference Table 7 |
| | 2 | Mode1 | Main Mode selection 2.bit | Reference Table 20 |
| | 1 | Mode0 | Main Mode selection 1.bit | Reference Table 20 |
| | 0 | Load_en | "1" mandatory | |
| 0000001 | 7 | Modulation1 | Modulation selection 2.bit | Reference Table 18 |
| | 6 | Modulation0 | Modulation selection 1.bit | Reference Table 18 |
| | 5 | OL_opamp_en | "0" mandatory | |
| | 4 | PA_LDc_en | "0" mandatory. PA on/off controlled by Lock Detect pin if this bit is 1 | |
| | 3 | RSSI_en | RSSI function on/off | |
| | 2 | LD_en | Lock detect function on/off | |
| | 1 | PF_FC1 | Pre-filter corner frequency 2.bit | Reference Table 14 |
| | 0 | PF_FC0 | Pre-filter corner frequency 1.bit | Reference Table 14 |
| 0000010 | 7 | CP_HI | High charge-pump current (4x=500uA) on/off | |
| | 6 | SC_by | Bypass of Switched Capacitor filter on/off | |
| | 5 | VCO_by | "0" mandatory. Bypass of VCO stage on/off | |
| | 4 | PA_by | Bypass of PA stage on/off | |
| | 3 | OUTS3 | Test pins output 4.bit | Reference Table 28 |
| | 2 | OUTS2 | Test pins output 3.bit | Reference Table 28 |
| | 1 | OUTS1 | Test pins output 2.bit | Reference Table 28 |
| | 0 | OUTS0 | Test pins output 1.bit | Reference Table 28 |
| 0000011 | 7 | IFBias_s | "1" mandatory. | |
| | 6 | IFA_HG | "1" mandatory.High gain setting in preamplifier | |
| | 5 | VCO_Bias_s | "0" mandatory.Select separate bias for VCO on VCOBias pin | |
| | 4 | VCO_IB2 | VCO bias current setting, 3. bit (111 = highest current) | Reference Table 11 |
| | 3 | VCO_IB1 | VCO bias current setting, 2. bit (100 = typical current) | Reference Table 11 |
| | 2 | VCO_IB0 | VCO bias current setting, 1. bit | Reference Table 11 |
| | 1 | VCO_freq1 | Frequency setting of VCO, 2. bit (11=highest frequency) | Reference Table 11 |
| | 0 | VCO_freq0 | Frequency setting of VCO, 1.bit | Reference Table 11 |
| 0000100 | 7 | Mod_F2 | Modulator filter setting, MSB | |
| | 6 | Mod_F1 | Modulator filter setting | |
| | 5 | Mod_F0 | Modulator filter setting, LSB | |
| | 4 | Mod_I4 | Modulator current setting, MSB | |
| | 3 | Mod_I3 | Modulator current setting | |
| | 2 | Mod_I2 | Modulator current setting | |
| | 1 | Mod_I1 | Modulator current setting | |

| ADR # | BIT # | Name | Description | Comments |
|---------|-------|---------------|---|----------|
| | 0 | Mod_I0 | Modulator current setting, LSB | |
| 0000101 | 7 | ----- | Reserved/not in use | |
| | 6 | ----- | Reserved/not in use | |
| | 5 | Mod_FHG | "0" mandatory. Modulator Test bit. | |
| | 4 | Mod_shape | "1" mandatory. Modulator shape enable | |
| | 3 | Mod_A3 | Modulator attenuator setting, LSB | |
| | 2 | Mod_A2 | Modulator attenuator setting | |
| | 1 | Mod_A1 | Modulator attenuator setting | |
| | 0 | Mod_A0 | Modulator attenuator setting, MSB (=0: Attenuator active) | |
| 0000110 | 7 | ----- | Reserved/not in use | |
| | 6 | Mod_clkS2 | Modulator clock setting 3.bit | |
| | 5 | Mod_clkS1 | Modulator clock setting 2.bit | |
| | 4 | Mod_clkS0 | Modulator clock setting 1.bit | |
| | 3 | BitSync_clkS2 | BitSync clock setting 3.bit | |
| | 2 | BitSync_clkS1 | BitSync clock setting 2.bit | |
| | 1 | BitSync_clkS0 | BitSync clock setting 1.bit | |
| | 0 | BitRate_clkS2 | Bitrate clock setting 3.bit | |
| 0000111 | 7 | BitRate_clkS1 | Bitrate clock setting 2.bit | |
| | 6 | BitRate_clkS0 | Bitrate clock setting 1.bit | |
| | 5 | RefClk_K5 | Reference clock divider 6.bit | |
| | 4 | RefClk_K4 | Reference clock divider 5.bit | |
| | 3 | RefClk_K3 | Reference clock divider 4.bit | |
| | 2 | RefClk_K2 | Reference clock divider 3.bit | |
| | 1 | RefClk_K1 | Reference clock divider 2.bit | |
| | 0 | RefClk_K0 | Reference clock divider 1.bit | |
| 0001000 | 7 | SC_HI | "1" mandatory. Switched Cap filter high current setting on/off | |
| | 6 | ScClk_X2 | "1" mandatory. Switched Cap clock multiplied by two | |
| | 5 | ScSw_EN | "0" mandatory. Switch cap switch enable | |
| | 4 | ScClk4 | SwitchCap clock divider 5.bit | |
| | 3 | ScClk3 | SwitchCap clock divider 4.bit | |
| | 2 | ScClk2 | SwitchCap clock divider 3.bit | |
| | 1 | ScClk1 | SwitchCap clock divider 2.bit | |
| | 0 | ScClk0 | SwitchCap clock divider 1.bit | |
| 0001001 | 7 | PrescalMode_s | "1" mandatory. Select external control of prescal mode (div32/33) | |
| | 6 | Prescale_s | "0" mandatory. Select external control of prescale mode (div 32/33) | |
| | 5 | XCOAR_en | "1" mandatory. XCO amplitude regulation on/off | |
| | 4 | XCOtune4 | Crystal oscillator trimming, LSB | |
| | 3 | XCOtune3 | Crystal oscillator trimming | |
| | 2 | XCOtune2 | Crystal oscillator trimming | |
| | 1 | XCOtune1 | Crystal oscillator trimming | |

| ADR # | BIT # | Name | Description | Comments |
|---------|-------|----------|----------------------------------|----------|
| | 0 | XCOtune0 | Crystal oscillator trimming, MSB | |
| 0001010 | 7 | ----- | Reserved/not in use | |
| | 6 | ----- | Reserved/not in use | |
| | 5 | A0_5 | A0-counter 6.bit | |
| | 4 | A0_4 | A0-counter 5.bit | |
| | 3 | A0_3 | A0-counter 4.bit | |
| | 2 | A0_2 | A0-counter 3.bit | |
| | 1 | A0_1 | A0-counter 2.bit | |
| | 0 | A0_0 | A0-counter 1.bit | |
| 0001011 | 7 | ----- | Reserved/not in use | |
| | 6 | ----- | Reserved/not in use | |
| | 5 | ----- | Reserved/not in use | |
| | 4 | ----- | Reserved/not in use | |
| | 3 | N0_11 | N0-counter 12.bit | |
| | 2 | N0_10 | N0-counter 11.bit | |
| | 1 | N0_9 | N0-counter 10.bit | |
| | 0 | N0_8 | N0-counter 9.bit | |
| 0001100 | 7 | N0_7 | N0-counter 8.bit | |
| | 6 | N0_6 | N0-counter 7.bit | |
| | 5 | N0_5 | N0-counter 6.bit | |
| | 4 | N0_4 | N0-counter 5.bit | |
| | 3 | N0_3 | N0-counter 4.bit | |
| | 2 | N0_2 | N0-counter 3.bit | |
| | 1 | N0_1 | N0-counter 2.bit | |
| | 0 | N0_0 | N0-counter 1.bit | |
| 0001101 | 7 | ----- | Reserved/not in use | |
| | 6 | ----- | Reserved/not in use | |
| | 5 | ----- | Reserved/not in use | |
| | 4 | ----- | Reserved/not in use | |
| | 3 | M0_11 | M0-counter 12.bit | |
| | 2 | M0_10 | M0-counter 11.bit | |
| | 1 | M0_9 | M0-counter 10.bit | |
| | 0 | M0_8 | M0-counter 9.bit | |
| 0001110 | 7 | M0_7 | M0-counter 8.bit | |
| | 6 | M0_6 | M0-counter 7.bit | |
| | 5 | M0_5 | M0-counter 6.bit | |
| | 4 | M0_4 | M0-counter 5.bit | |
| | 3 | M0_3 | M0-counter 4.bit | |
| | 2 | M0_2 | M0-counter 3.bit | |
| | 1 | M0_1 | M0-counter 2.bit | |
| | 0 | M0_0 | M0-counter 1.bit | |
| 0001111 | 7 | ----- | Reserved/not in use | |
| | 6 | ----- | Reserved/not in use | |

| ADR # | BIT # | Name | Description | Comments |
|---------|-------|---------|--|----------|
| | 5 | A1_5 | A1-counter 6.bit | |
| | 4 | A1_4 | A1-counter 5.bit | |
| | 3 | A1_3 | A1-counter 4.bit | |
| | 2 | A1_2 | A1-counter 3.bit | |
| | 1 | A1_1 | A1-counter 2.bit | |
| | 0 | A1_0 | A1-counter 1.bit | |
| 0010000 | 7 | ----- | Reserved/not in use | |
| | 6 | ----- | Reserved/not in use | |
| | 5 | ----- | Reserved/not in use | |
| | 4 | ----- | Reserved/not in use | |
| | 3 | N1_11 | N1-counter 12.bit | |
| | 2 | N1_10 | N1-counter 11.bit | |
| | 1 | N1_9 | N1-counter 10.bit | |
| | 0 | N1_8 | N1-counter 9.bit | |
| 0010001 | 7 | N1_7 | N1-counter 8.bit | |
| | 6 | N1_6 | N1-counter 7.bit | |
| | 5 | N1_5 | N1-counter 6.bit | |
| | 4 | N1_4 | N1-counter 5.bit | |
| | 3 | N1_3 | N1-counter 4.bit | |
| | 2 | N1_2 | N1-counter 3.bit | |
| | 1 | N1_1 | N1-counter 2.bit | |
| | 0 | N1_0 | N1-counter 1.bit | |
| 0010010 | 7 | ----- | Reserved/not in use | |
| | 6 | ----- | Reserved/not in use | |
| | 5 | ----- | Reserved/not in use | |
| | 4 | ----- | Reserved/not in use | |
| | 3 | M1_11 | M1-counter 12.bit | |
| | 2 | M1_10 | M1-counter 11.bit | |
| | 1 | M1_9 | M1-counter 10.bit | |
| | 0 | M1_8 | M1-counter 9.bit | |
| 0010011 | 7 | M1_7 | M1-counter 8.bit | |
| | 6 | M1_6 | M1-counter 7.bit | |
| | 5 | M1_5 | M1-counter 6.bit | |
| | 4 | M1_4 | M1-counter 5.bit | |
| | 3 | M1_3 | M1-counter 4.bit | |
| | 2 | M1_2 | M1-counter 3.bit | |
| | 1 | M1_1 | M1-counter 2.bit | |
| | 0 | M1_0 | M1-counter 1.bit | |
| 0010100 | 7 | Div2_HI | "1" mandatory. High bias current setting in Div2 circuit on/off | |
| | 6 | LO_IB1 | "0" mandatory. Bias current setting of LObuffer, 2. bit (11 = highest current) | |

| ADR # | BIT # | Name | Description | Comments |
|---------|-------|--------|--|--------------------|
| | 5 | LO_IB0 | "1" mandatory. Bias current setting of LObuffer, 1. bit (01 = typical current) | |
| | 4 | PA_IB4 | "0" mandatory. Bias current setting of PA, 2. bit (11 = highest current) | |
| | 3 | PA_IB3 | "0" mandatory. Bias current setting of PA, 1. bit (01 = typical current) | |
| | 2 | PA_IB2 | "0" mandatory. Bias current setting of PAbuffer, 3. bit | |
| | 1 | PA_IB1 | "1" mandatory. Bias current setting of PAbuffer, 2. bit | |
| | 0 | PA_IB0 | "1" mandatory. Bias current setting of PAbuffer, 1. bit | |
| 0010101 | 7 | ----- | Reserved/not in use | |
| | 6 | ----- | Reserved/not in use | |
| | 5 | ----- | Reserved/not in use | |
| | 4 | ----- | Reserved/not in use | |
| | 3 | FEEC_3 | FEE control bit | Reference Table 15 |
| | 2 | FEEC_2 | FEE control bit | Reference Table 15 |
| | 1 | FEEC_1 | FEE control bit | Reference Table 15 |
| | 0 | FEEC_0 | FEE control bit | Reference Table 15 |
| 0010110 | 7 | FEE_7 | FEE value, bit 7, MSB | |
| | 6 | FEE_6 | FEE value, bit 6 | |
| | 5 | FEE_5 | FEE value, bit 5 | |
| | 4 | FEE_4 | FEE value, bit 4 | |
| | 3 | FEE_3 | FEE value, bit 3 | |
| | 2 | FEE_2 | FEE value, bit 2 | |
| | 1 | FEE_1 | FEE value, bit 1 | |
| | 0 | FEE_0 | FEE value, bit 0, LSB | |

Table 26. Detailed Description of Programming Bits

| Category | Field Name | Number of Bits | Location of Bits | Description | Reference |
|-------------------------|--------------|----------------|---------------------------|--|---------------------------|
| Clocking | XCOtune | 5 | Reg9[4:0] | Crystal oscillator trimming | |
| | RefClk_K | 6 | Reg7[5:0] | Reference clock divider | |
| | BitRate_clkS | 3 | Reg6[0], Reg7[7:6] | Bitrate clock setting | |
| | Mod_clkS | 3 | Reg6[6:4] | Modulator clock setting | |
| | BitSync_clkS | 3 | Reg6[3:1] | BitSync clock setting | |
| Datal/F | Sync_en | 1 | Reg0[3] | Synchronizer Mode bit | Table 7 |
| Synthesizer | M0 | 12 | Reg13[3:0], Reg14[7:0] | M0 counter | |
| | A0 | 6 | Reg10[5:0] | A0 counter | |
| | N0 | 12 | Reg11[3:0], Reg12[7:0] | N0 counter | |
| | M1 | 12 | Reg18[3:0], Reg19[7:0] | M1 counter | |
| | A1 | 6 | Reg15[5:0] | A1 counter | |
| | N1 | 12 | Reg16[3:0], Reg17[7:0] | N1 counter | |
| | CP_HI | 1 | Reg2[7] | High charge pump current (500 μ A = 4x) on/off | |
| | VCO_Freq | 2 | Reg3[1:0] | Frequency setting of VCO (highest frequency at 11) | |
| | VCO_IB | 3 | Reg3[4:2] | VCO bias current setting (highest current at 111, 100 typical) | |
| | LD_en | 1 | Reg1[2] | Lock detect function on/off | |
| Receive | By_LNA | 1 | Reg0[7] | LNA bypass on/off | |
| | PF_FC | 2 | Reg1[1:0] | Pre-filter corner frequency | Table 14 |
| | SC_by | 1 | Reg2[6] | Bypass of switched capacitor filter on/off | |
| | ScClk | 5 | Reg8[4:0] | Switched Cap clock divider | |
| | RSSI_en | 1 | Reg1[3] | RSSI function on/off | |
| | FEEC | 4 | Reg21[3:0] | FEE control bits | Table 15 |
| | | FEE | 8 | Reg22[7:0] | FEE value (read only) |
| Transmit/VCO modulation | Modulation | 2 | Reg1[7:6] | Modulation selection | Table 18 |
| | Mod_I | 5 | Reg4[4:0] | Modulator current setting | |
| | Mod_A | 4 | Reg5[3:0] | Modulator attenuator setting | |
| | Mod_F | 3 | Reg4[7:5] | Modulator filter setting | |
| | PA | 3 | Reg0[6:4] | Power amplifier level | Table 17 |
| | | PA_by | 1 | Reg2[4] | Bypass of PA stage on/off |
| System | Mode | 2 | Reg0[2:1] | Main mode selection | Table 20 |
| | | OUTS | 4 | Reg2[3:0] | Test pins output |

Table 27. Register Fields

| OutS3 | OutS2 | OutS1 | OutS0 | IchOut | QchOut | Ichout2 / RSSI | QchOut2 / NC |
|-------|-------|-------|-------|--------------|--------------|----------------|--------------|
| 0 | 0 | 0 | 0 | Gnd | Gnd | Gnd | Gnd |
| 0 | 0 | 0 | 1 | Ip mixer | In mixer | Ip IFamp | In IFamp |
| 0 | 0 | 1 | 0 | Qp mixer | Qn mixer | Qp IFamp | Qn IFamp |
| 0 | 0 | 1 | 1 | Ip IFamp | In IFamp | Ip SC-filter | In SC-filter |
| 0 | 1 | 0 | 0 | Qp IFamp | Qn IFamp | Qp SC-filter | Qn SC-filter |
| 0 | 1 | 0 | 1 | Ip SC-filter | In SC-filter | Gnd | I limiter |
| 0 | 1 | 1 | 0 | Qp SC-filter | Qn SC-filter | Gnd | Q limiter |
| 0 | 1 | 1 | 1 | Ip mixer | In mixer | Ip SC-filter | In SC-filter |
| 1 | 0 | 0 | 0 | Qp mixer | Qn mixer | Qp SC-filter | Qn SC-filter |
| 1 | 0 | 0 | 1 | Ip mixer | In mixer | Gnd | I limiter |
| 1 | 0 | 1 | 0 | Qp mixer | Qn mixer | Gnd | Q limiter |
| 1 | 0 | 1 | 1 | Ip mixer | Qp mixer | ModIn | PrescalMode |
| 1 | 1 | 0 | 0 | Ip IFamp | Qp IFamp | TI1 | TQ1 |
| 1 | 1 | 0 | 1 | Ip SC-filter | Qp SC-filter | DemodUp | DemodDn |
| 1 | 1 | 1 | 0 | I limiter | Q limiter | Demod | MAout |
| 1 | 1 | 1 | 1 | N-div | M-div | Phi1n | Phi2n |

Table 28. Test Signals

Package Information⁽¹¹⁾ and Recommended Landing Pattern

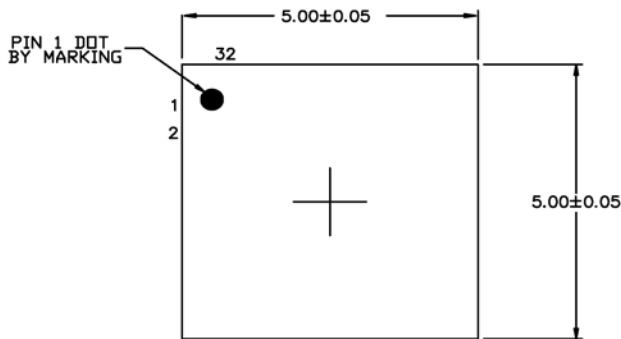

TOP VIEW
NOTE: 1, 2, 3

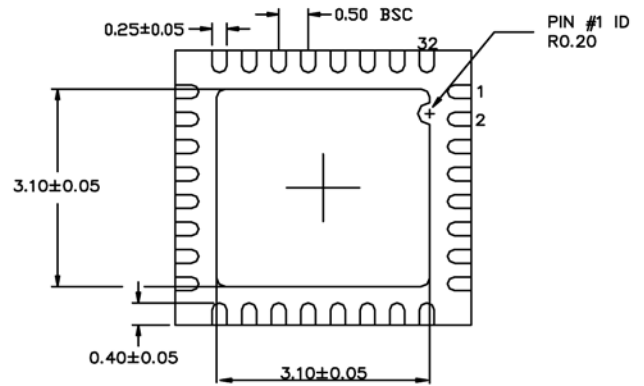

BOTTOM VIEW
NOTE: 1, 2, 3

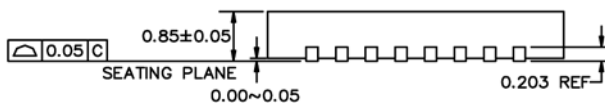

SIDE VIEW
NOTE: 1, 2, 3

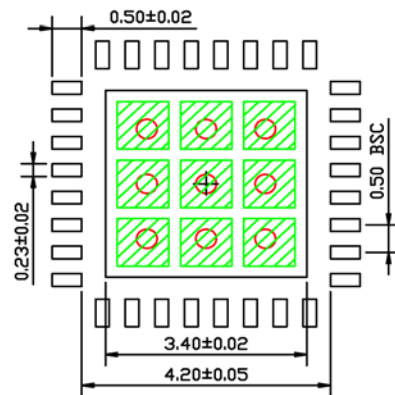

RECOMMENDED LAND PATTERN
NOTE: 4, 5

NOTE:

1. MAX PACKAGE WARPAGE IS 0.05 MM
2. MAX ALLOWABLE BURR IS 0.076MM IN ALL DIRECTIONS
3. PIN #1 IS ON TOP WILL BE LASER MARKED
4. RED CIRCLE IN LAND PATTERN INDICATE THERMAL VIA. SIZE SHOULD BE 0.30-0.3MM IN DIAMETER AND SHOULD BE CONNECTED TO GND FOR MAX THERMAL PERFORMANCE
5. GREEN RECTANGLES (SHADED AREA) INDICATE SOLDER STENCIL OPENING ON EXPOSED PAD AREA. SIZE SHOULD BE 0.87x0.87 MM IN SIZE, 1.07 MM PITCH.

32-Pin QFN (ML)

Note:

11. Package information is correct as of the publication date. For updates and most current information, go to www.micrel.com.

MICREL, INC. 2180 FORTUNE DRIVE SAN JOSE, CA 95131 USA
TEL +1 (408) 944-0800 FAX +1 (408) 474-1000 WEB <http://www.micrel.com>

Micrel makes no representations or warranties with respect to the accuracy or completeness of the information furnished in this data sheet. This information is not intended as a warranty and Micrel does not assume responsibility for its use. Micrel reserves the right to change circuitry, specifications and descriptions at any time without notice. No license, whether express, implied, arising by estoppel or otherwise, to any intellectual property rights is granted by this document. Except as provided in Micrel's terms and conditions of sale for such products, Micrel assumes no liability whatsoever, and Micrel disclaims any express or implied warranty relating to the sale and/or use of Micrel products including liability or warranties relating to fitness for a particular purpose, merchantability, or infringement of any patent, copyright or other intellectual property right.

Micrel Products are not designed or authorized for use as components in life support appliances, devices or systems where malfunction of a product can reasonably be expected to result in personal injury. Life support devices or systems are devices or systems that (a) are intended for surgical implant into the body or (b) support or sustain life, and whose failure to perform can be reasonably expected to result in a significant injury to the user. A Purchaser's use or sale of Micrel Products for use in life support appliances, devices or systems is a Purchaser's own risk and Purchaser agrees to fully indemnify Micrel for any damages resulting from such use or sale.

© 2010 Micrel, Incorporated

Mouser Electronics

Authorized Distributor

Click to View Pricing, Inventory, Delivery & Lifecycle Information:

[Micrel:](#)

[MICRF507YML-TR](#)