

## Safety Relay Unit

- Four kinds of 45-mm wide units are available:  
A 3-pole model, a 5-pole model, and models with 3 poles and 2 OFF-delay poles, as well as a two-hand controller.  
Also available are 17.5 mm wide expansion units with 3 poles and 3 OFF-delay poles.
- Simple expansion connection
- OFF-delay models have 15-step OFF-delay settings
- Conforms to EN standards (BG approval)
- Both DIN track mounting and screw mounting are possible



## Specifications

### Ratings

#### Power Input

	G9SA-301/TH301	G9SA-501	G9SA-321-T□
Power supply voltage	24 VAC/VDC: 24 VAC, 50/60 Hz, or 24 VDC 100 to 240 VAC: 100 to 240 VAC, 50/60 Hz		
Operating voltage range	85% to 110% of rated power supply voltage		
Power consumption *	24 VAC/VDC: 1.8 VA/ 1.7 W max. 100 to 240 VAC: 9 VA max.	24 VAC/VDC: 2.8 VA/ 2.6 W max. 100 to 240 VAC: 11 VA max.	24 VAC/VDC: 3.5 VA/ 3.3 W max. 100 to 240 VAC: 12.5 VA max.

\*When an Expansion Unit is connected, the power consumption is increased by 2 VA/2 W max.

#### Inputs

	G9SA-301/321-T□/TH301	G9SA-501
Input current *	40 mA max.	60 mA max.

\* When an Expansion Unit is connected, the input current is increased by 30 mA max.

#### Contacts

	G9SA-301/501/321-T□/TH301/EX301/EX031-T□
	<b>Resistive load</b>
Rated load	250 VAC, 5 A 30 VDC, 5 A
Rated carry current	5 A

## Specifications (continued)

### Characteristics

		G9SA-301/TH301	G9SA-501/321-T□	G9SA-EX301/EX031-T□
Contact resistance *1		100 mΩW		
Operating time *2		30 ms max.		
Response time *3		10 ms max.		
Insulation resistance *4		100 MΩ min. (at 500 VDC)		
Dielectric strength	Between different outputs	2,500 VAC, 50/60 Hz for 1 min		
	Between inputs and outputs			
	Between power inputs and outputs			
	Between power inputs and other inputs (only for 100 to 240-V models)			
Vibration resistance		10 to 55 to 10 Hz, 0.375 mm single amplitude (0.75 mm double amplitude)		
Shock resistance	Destruction	300 m/s <sup>2</sup>		
	Malfunction	100 m/s <sup>2</sup>		
Durability *5	Mechanical	5,000,000 operations min. (at approx. 7,200 operations/hr)		
	Electrical	100,000 operations min. (at approx. 1,800 operations/hr)		
Failure rate (P Level) (reference value)		5 VDC, 1 mA		
Ambient operating temperature		-25 to 55°C (with no icing or condensation)		
Ambient operating humidity		35% to 85%		
Terminal tightening torque		0.98 N·m		
Weight *6		Approx. 210 g	Approx. 270 g	Approx. 130 g

\*1. The contact resistance was measured with 1 A at 5 VDC using the voltage-drop method.

\*2. Not including bounce time.

\*3. The response time is the time it takes for the main contact to open after the input is turned OFF. Includes bounce time.

\*4. The insulation resistance was measured with 500 VDC at the same places that the dielectric strength was checked.

\*5. The durability is for an ambient temperature of 15 to 35°C and an ambient humidity of 25% to 75%.

\*6. Weight shown is for 24-VAC/VDC type. For 100 to 240 VAC type, add approximately 20 g.

## Applications

### G9SA-TH301 (24 VDC) with 2-hand Inputs

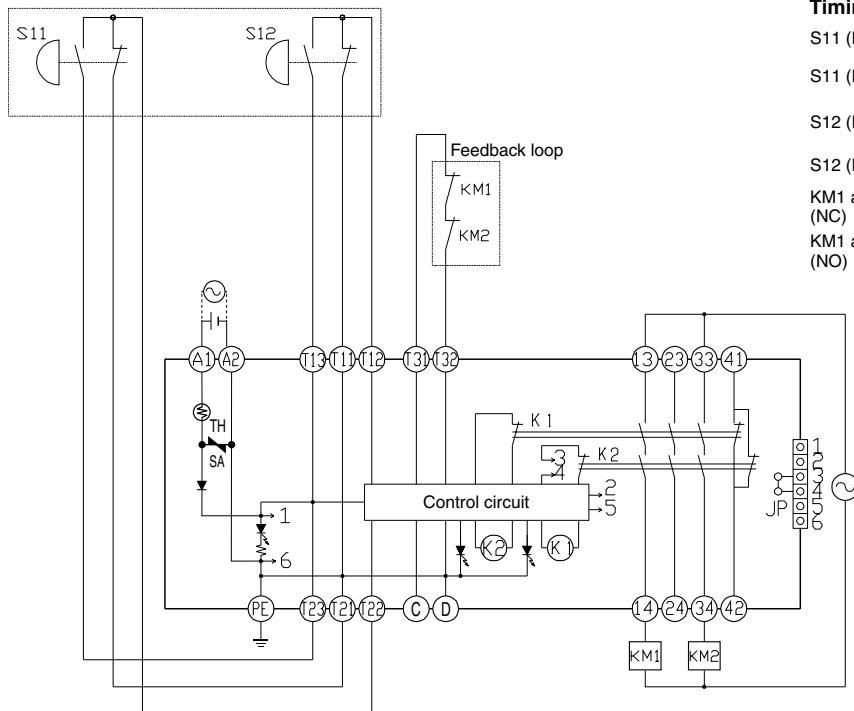

#### Timing Chart

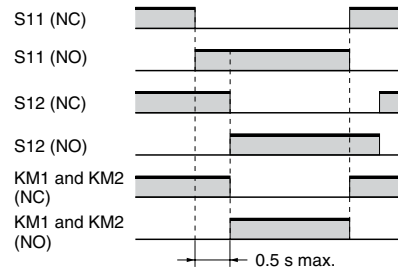

Input time difference operates only when the difference is 0.5 s max.

S11, S12: Two-hand pushbutton switches  
KM1 and KM2: Magnetic Contactor

**Note:** 1. Use a 1NC+1NO switch for S11 and S12.

2. This circuit achieves Safety Category 4.

## Applications (continued)

### G9SA-301 (24 VAC/VDC) with 2-channel Safety Sensor/Manual Reset

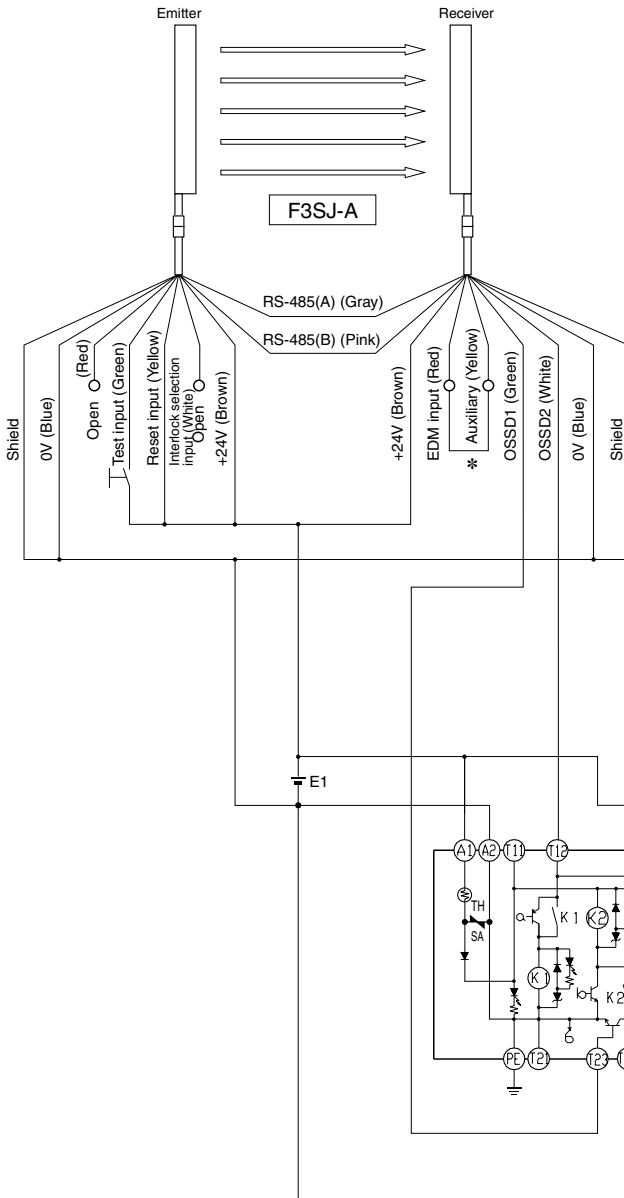

#### Timing Chart

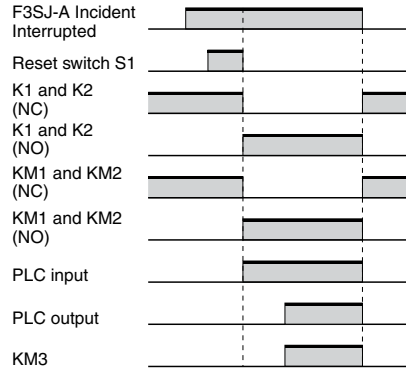

- F3SJ-A: Safety sensor
- S1: Reset switch
- KM1 and KM2: Magnetic Contactor
- KM3: G3J Solid-state Contactor (G3J)
- M: 3-phase motor
- E1: 24-VDC Power Supply (S82K)

**Note:** This circuit achieves Safety Category 4.

\* The F3SJ-A auxiliary output wiring is shown for dark-ON operation.

## Applications (continued)

### G9SA-501 (24 VAC/VDC) and G9SA-EX301 with 2-channel Limit Switch Input/Manual Reset

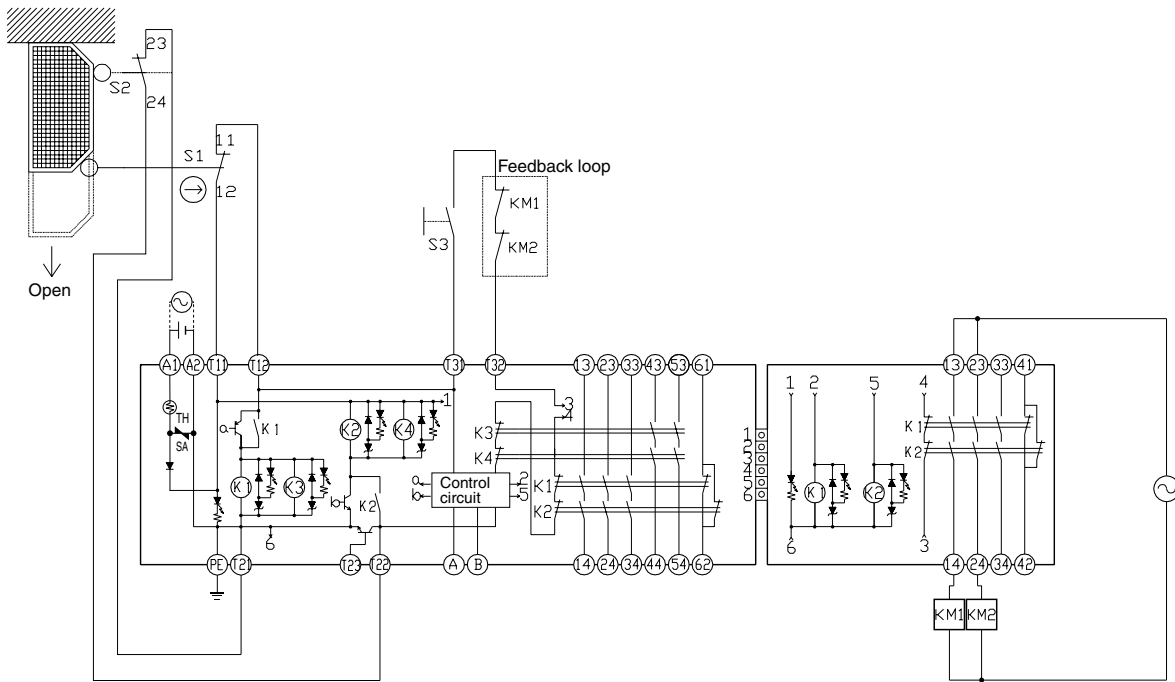

- S1: Safety Limit Switch with direct opening mechanism (NC) (D4B-N, D4N, D4F) ⊖
- S2: Limit switch (NO)
- S3: Reset switch
- KM1 and KM2: Magnetic Contactor
- M: 3-phase motor

#### Timing Chart

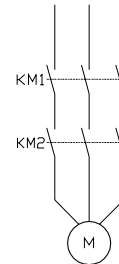
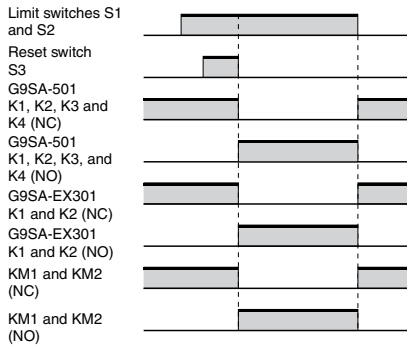

**Note:** This circuit achieves Safety Category 4.

Dimensions and Terminal Arrangement

(mm)

G9SA-301  
G9SA-501  
G9SA-321-T□  
G9SA-TH301

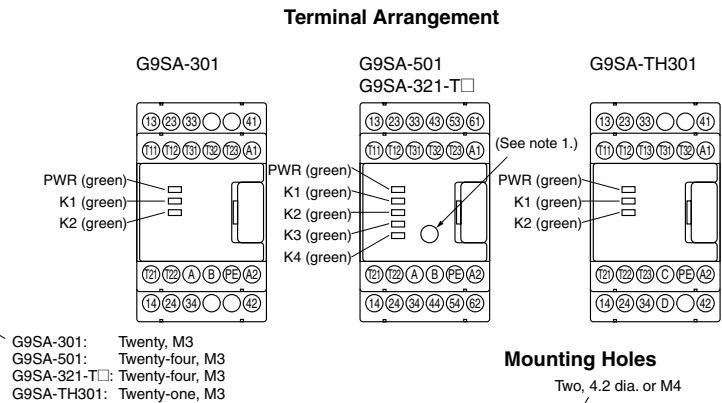
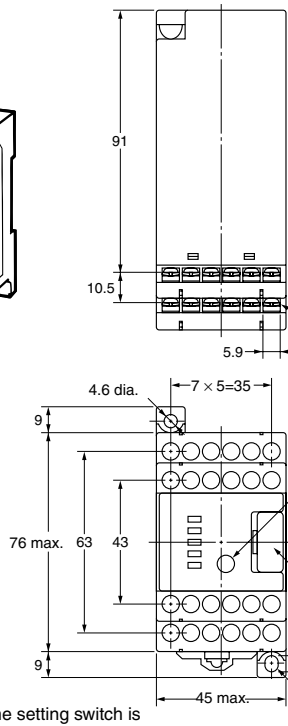
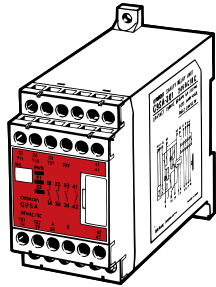

G9SA-301: Twenty, M3  
G9SA-501: Twenty-four, M3  
G9SA-321-T□: Twenty-four, M3  
G9SA-TH301: Twenty-one, M3

**Mounting Holes**

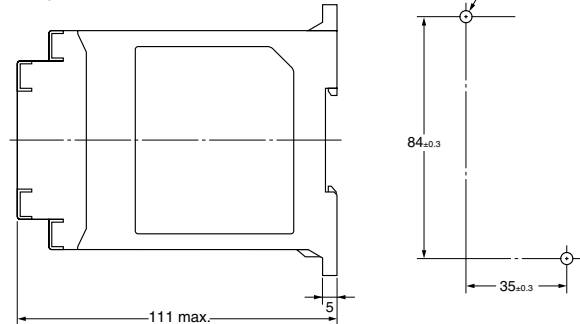

- Note 1:** The OFF-delay time setting switch is found on the G9SA-321-T□ only.  
**Note 2:** The K1 to K4 indicators light when the NO contacts of internal relays K1 to K4 close.  
\* Do not remove unless an Expansion Unit is being used.

G9SA-EX301  
G9SA-EX031-T□

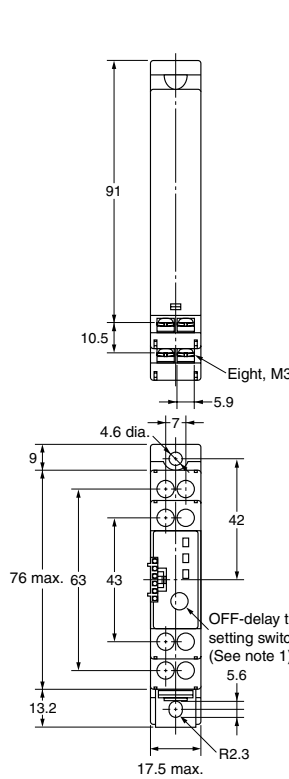
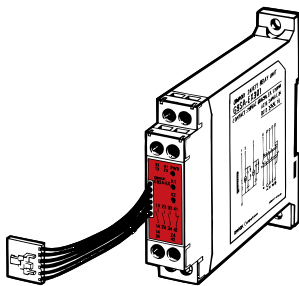

**Mounting Holes**

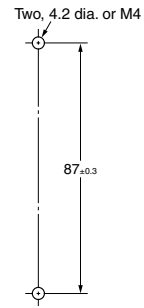

**Terminal Arrangement**

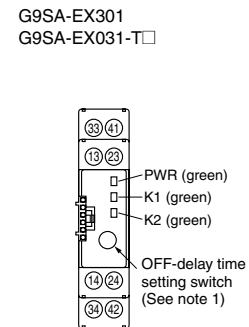

- Note 1:** The OFF-delay time setting switch is found on the G9SA-EX031-T□ only.  
**Note 2:** The K1 and K2 indicators light when the NO contacts of internal relays K1 and K2 close.

## Ordering

### Model Number Legend

G9SA - □ □ □ □ □ - □ □ □ □  
 ① ② ③ ④ ⑤ ⑥

- |   |   |
|---|---|
| <p>① Function<br/>         None: Emergency stop<br/>         EX: Expansion Unit<br/>         TH: Two-hand Controller</p> <p>② Contact Configuration (Safety Output)<br/>         0: None<br/>         3: 3PST-NO<br/>         5: 5PST-NO</p> <p>③ Contact Configuration (OFF-delay Output)<br/>         0: None<br/>         2: DPST-NO<br/>         3: 3PST-NO</p> | <p>④ Contact Configuration (Auxiliary Output)<br/>         0: None<br/>         1: SPST-NC</p> <p>⑤ Input Configuration<br/>         None: 1-channel or 2-channel input possible</p> <p>⑥ OFF-delay Time (Max. setting time)<br/>         None: No OFF-delay<br/>         T075: 7.5 seconds<br/>         T15: 15 seconds<br/>         T30: 30 seconds</p> <p>Note: Call the factory for G9SA models designed for positive ground system. These are available for 24 VDC only.</p> |
|---|---|

### Specific Models

#### Emergency-stop Units

Main contacts	Auxiliary contact	Number of input channels	Rated voltage	Model
3PST-NO	SPST-NC	1 channel or 2 channels possible	24 VAC/VDC	G9SA-301
5PST-NO			100 to 240 VAC	
			24 VAC/VDC	G9SA-501
100 to 240 VAC				

#### Emergency-stop OFF-delay Units

Main contacts	OFF-delay contacts	Auxiliary contact	Number of input channels	OFF-delay time	Rated voltage	Model
3PST-NO	DPST-NO	SPST-NC	1 channel or 2 channels possible	7.5 s	24 VAC/VDC	G9SA-321-T075
					100 to 240 VAC	
				15 s	24 VAC/VDC	G9SA-321-T15
					100 to 240 VAC	
				30 s	24 VAC/VDC	G9SA-321-T30
					100 to 240 VAC	

Note: Set to maximum values in the factory.

- \* The following 15-step OFF-delay time settings are available:  
 T075: 0.5, 1, 1.5, 2, 2.5, 3, 3.5, 4, 4.5, 5, 5.5, 6, 6.5, 7, and 7.5 s  
 T15: 1, 2, 3, 4, 5, 6, 7, 8, 9, 10, 11, 12, 13, 14, and 15 s  
 T30: 2, 4, 6, 8, 10, 12, 14, 16, 18, 20, 22, 24, 26, 28, and 30 s

#### Two-hand Controller

Main contacts	Auxiliary contact	Number of input channels	Rated voltage	Model
3PST-NO	SPST-NC	2 channels	24 VAC/VDC	G9SA-TH301
			100 to 240 VAC	

#### Expansion Unit

The Expansion Unit connects to a G9SA-301, G9SA-501, G9SA-321, or G9SA-TH301.

Main contacts	Auxiliary contact	Model
3PST-NO	SPST-NC	G9SA-EX301

#### Expansion Units with OFF-delay Outputs

The Expansion Unit connects to a G9SA-301, G9SA-501, G9SA-321, or G9SA-TH301.

Main contact form	Auxiliary contact	OFF-delay time	Model
3PST-NO	SPST-NC	7.5 s	G9SA-EX031-T075
		15 s	G9SA-EX031-T15
		30 s	G9SA-EX031-T30

Note: Set to maximum values in the factory.

- \* The following 15-step OFF-delay time settings are available:  
 T075: 0.5, 1, 1.5, 2, 2.5, 3, 3.5, 4, 4.5, 5, 5.5, 6, 6.5, 7, and 7.5 s  
 T15: 1, 2, 3, 4, 5, 6, 7, 8, 9, 10, 11, 12, 13, 14, and 15 s  
 T30: 2, 4, 6, 8, 10, 12, 14, 16, 18, 20, 22, 24, 26, 28, and 30 s

 = Highlighted **Rapid Delivery** products are available for shipment today or within **FIVE** days.