

# WPMDB1960501XF / 171960501

## MagI<sup>3</sup>C Power Module VDM – Variable Step Down MicroModule

2.7V – 5.5V / 0.6A / 0.6V – 5.5V Output



### DESCRIPTION

The VDM 171960501 MagI<sup>3</sup>C MicroModule provides a fully integrated DC-DC power supply including the switching regulator with integrated MOSFETs, compensation and shielded inductor in one package.

The 171960501 offers high efficiency and delivers up to 0.6A of output current. It operates with an input voltage from 2.7V to 5.5V and is designed for small solution size.

The selectable forced PWM or PFM/PWM mode allows for the choice between high efficiency and low output voltage ripple at light load.

It is available in an LGA-6EP package (3.2 x 2.5 x 1.6mm).

This module has integrated protection circuitry that guards against thermal overstress with thermal shutdown and protects against electrical damage using overcurrent, short-circuit and undervoltage protections.

### TYPICAL APPLICATIONS

- General point of load power supply for low power systems
- Replacement of linear regulators
- DSP and FPGA power supply auxiliary voltages
- Portable instruments
- Battery powered equipment

### FEATURES

- Peak efficiency up to 96%
- Current capability up to 0.6A
- Input voltage range: 2.7V to 5.5V
- Output voltage range: 0.6V to 5.5V
- 30  $\mu$ A typical quiescent current
- Integrated shielded inductor and input and output capacitors (partially)
- Low output voltage ripple: <2mV typ.
- Output voltage accuracy over temperature: 2% max.
- Fixed switching frequency: 2.25 MHz
- Voltage Mode control
- Synchronous operation
- Selectable forced PWM or PFM/PWM mode
- Undervoltage lockout protection (UVLO)
- Embedded soft-start
- Thermal shutdown
- Short-circuit protection
- Cycle-by-cycle current limit
- RoHS und REACH compliant
- Operating ambient temperature up to 85°C
- No output current derating within the operating temperature range
- Operating junction temp. range: -40 to 125°C
- Complies with EN55022 class B radiated emissions standard

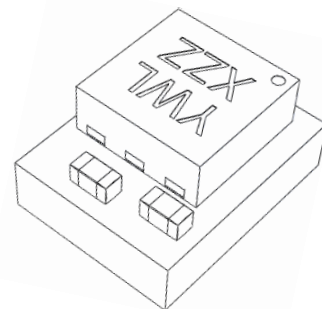

### TYPICAL CIRCUIT DIAGRAM

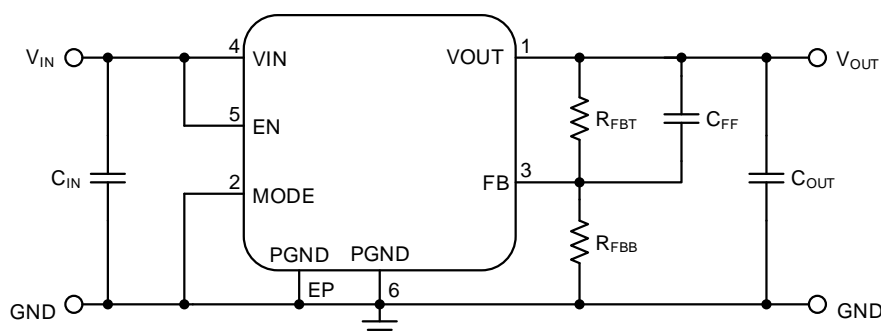

# WPMDB1960501XF / 171960501

**Mag<sup>3</sup>C** Power Module  
**VDMM** – Variable Step Down MicroModule



## PACKAGE

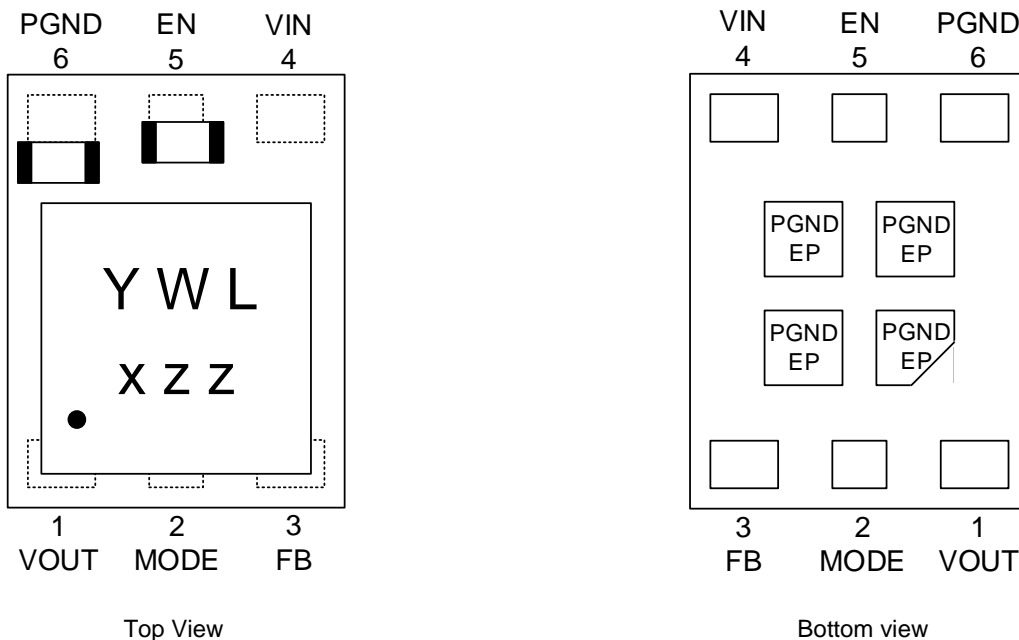

## MARKING DESCRIPTION

Marking	Description
Y	Year
W	Calendar week
L	Lot number
x	Product Code
zz	Voltage Code

## PIN DESCRIPTION

SYMBOL	NUMBER	TYPE	DESCRIPTION
VOUT	1	Power	Output voltage. Place output capacitors as close as possible. For best thermal performance use copper plane(s) at this pin.
MODE	2	Input	Forced PWM or PFM/PWM mode selection pin. Setting this pin high, the forced PWM mode is selected for any load current. Setting this pin low, PFM/PWM is selected, with the transition automatically between the two operations according to the load. This pin must not be left floating.
FB	3	Input	Feedback pin. This pin must be connected to the external resistor divider (between VOUT and GND) to adjust the output voltage.
VIN	4	Power	Input voltage. Place the input capacitor as close as possible.
EN	5	Input	Enable pin. Setting this pin high enables the device, while setting this pin low shuts down the device. This pin must not be left floating.
PGND	6	Power	Power Ground. It must be connected to the ground plane and the Thermal Pads.
PGND	EP	Exposed Pads	Exposed Pads. These pins are internally electrically connected to PGND. It is recommended to connect them to the ground plane for device heat dissipation

**WPMDB1960501XF / 171960501**

**MagI<sup>3</sup>C** Power Module  
**VDMM** – Variable Step Down MicroModule

**ORDERING INFORMATION**

ORDER CODE	PART DESCRIPTION	SPECIFICATIONS	PACKAGE	PACKAGING UNIT
171960501	WPMDB1960501XF	0.6A / 0.6-5.5Vout version	LGA-6EP	Reel (2000 pieces)
178960501	-	0.6A / 0.6-5.5Vout version	Eval Board	

**SALES INFORMATION**

SALES CONTACTS
<p>Würth Elektronik eiSos GmbH &amp; Co. KG            EMC &amp; Inductive Solutions            Max-Eyth-Str. 1            74638 Waldenburg            Germany            Tel. +49 (0) 7942 945 0            www.we-online.com            powermodules@we-online.com</p>

# WPMDB1960501XF / 171960501

**MagI<sup>3</sup>C** Power Module  
**VDMM** – Variable Step Down MicroModule



## ABSOLUTE MAXIMUM RATINGS

Caution:

Exceeding the listed absolute maximum ratings may affect the device negatively and may cause permanent damage.

SYMBOL	PARAMETER	LIMITS		UNIT
		MIN <sup>(1)</sup>	MAX <sup>(1)</sup>	
V <sub>IN</sub>	Input voltage	-0.3	6	V
V <sub>OUT</sub>	Output voltage	-0.3	V <sub>IN</sub>	V
FB	Feedback pin	-0.3	V <sub>IN</sub>	V
EN	Enable pin	-0.3	V <sub>IN</sub> +0.3	V
MODE	Mode pin	-0.3	V <sub>IN</sub>	V
T <sub>storage</sub>	Assembled, non-operating storage temperature	-65	150	°C
V <sub>ESD</sub>	ESD voltage (HBM), all pins (C=100pF, R= 1.5kΩ)	-2	2	kV

## OPERATING CONDITIONS

Operating conditions are conditions under which the device is intended to be functional. All values are referenced to GND.

MIN and MAX limits are valid for the recommended ambient temperature range of **-40°C to 85°C**. Typical values represent statistically the utmost probable values at the following conditions: V<sub>IN</sub> = 5V, V<sub>OUT</sub> = 1.8V, C<sub>IN</sub> = C<sub>OUT</sub> = 10μF ceramic, unless otherwise noted.

SYMBOL	PARAMETER	MIN <sup>(1)</sup>	TYP <sup>(2)</sup>	MAX <sup>(1)</sup>	UNIT
V <sub>IN</sub>	Input voltage	2.7	-	5.5	V
V <sub>OUT</sub>	Output voltage (depending on the external resistor divider)	0.6	-	5.5	V
T <sub>A</sub>	Ambient temperature range	-40	-	85 <sup>(3)</sup>	°C
T <sub>JOP</sub>	Junction temperature range	-40	-	125	°C
I <sub>OUT</sub>	Nominal output current			0.6	A

## THERMAL SPECIFICATIONS

SYMBOL	PARAMETER	TYP <sup>(2)</sup>	UNIT
Θ <sub>JA</sub>	Junction-to-ambient thermal resistance <sup>(4)</sup>	150	°C/W
TSD	Thermal shutdown, rising	150	°C
	Thermal shutdown hysteresis, falling	20	°C

## WPMDB1960501XF / 171960501

**Magl<sup>3</sup>C** Power Module  
**VDMM** – Variable Step Down MicroModule

**ELECTRICAL SPECIFICATIONS**

MIN and MAX limits are valid for the recommended ambient temperature range of **-40°C to 85°C**. Typical values represents statistically the utmost probable values at the following conditions:  $V_{IN} = 5V$ ,  $V_{OUT} = 1.8V$ ,  $C_{IN} = C_{OUT} = 10\mu F$  ceramic, unless otherwise noted.

SYMBOL	PARAMETER	TEST CONDITIONS	MIN <sup>(1)</sup>	TYP <sup>(2)</sup>	MAX <sup>(1)</sup>	UNIT
<b>Output current</b>						
$I_{OCP}$	Overcurrent protection	$T_A = 25^\circ C$	1	2.4	-	A
<b>Output accuracy</b>						
$V_{FB}$	Reference voltage	$T_A = 25^\circ C$	0.594	0.6	0.606	V
	Temperature variation	$-40^\circ C \leq T_A \leq 85^\circ C$	0.588	0.6	0.612	V
$I_{FB}$	Input current feedback pin		-100	-	100	nA
$V_{OUT}$	Line regulation	$V_{IN} = 2.7V$ to $5V$ , $T_A = 25^\circ C$ , MODE = high	-	$\pm 0.2$	-	%/V
	Load regulation	$V_{IN} = 2.7V$ , $V_{OUT} = 1.8V$ over $I_{OUT}$ range, MODE = high, $T_A = 25^\circ C$	-	$\pm 0.5$	-	%/A
	Output voltage ripple	$V_{IN} = 3.6V$ , $V_{OUT} = 1.8V$ , $I_{OUT} = 600mA$ MODE = high, 20MHz BW, $T_A = 25^\circ C$ <sup>(5)</sup>	-	1	-	mV
		$V_{IN} = 3.6V$ , $V_{OUT} = 1.8V$ , $I_{OUT} = 50mA$ MODE = low, 20MHz BW, $T_A = 25^\circ C$ <sup>(5)</sup>	-	30	-	mV
<b>Switching frequency</b>						
$f_{SW}$	Switching frequency		1.65	2.25	2.76	MHz
<b>Enable and undervoltage lockout</b>						
$V_{UVLO}$	$V_{IN}$ undervoltage threshold	$V_{IN}$ increasing	-	2.15	2.3	V
	$V_{IN}$ undervoltage hysteresis	$T_A = 25^\circ C$	-	0.15	-	V
$V_{ENABLE}$	Enable threshold	Enable logic high voltage	2	-	-	V
		Enable logic low voltage	0	-	0.3	V
$I_{ENABLE}$	Enable input current		-500	-	500	nA
<b>MODE selection</b>						
$V_{MODE}$	MODE threshold high	$T_A = 25^\circ C$	$V_{IN}-0.5$	-	-	V
	MODE threshold low	$T_A = 25^\circ C$	0	-	0.3	V
$I_{MODE}$	MODE current consumption	MODE = high, $T_A = 25^\circ C$		30		nA
		MODE = low, $T_A = 25^\circ C$		-40		nA
<b>Soft-Start</b>						
$T_{SS}$	Soft-start duration	$T_A = 25^\circ C$ (10%-90% of $V_{OUT}$ )		550		$\mu s$

# WPMDB1960501XF / 171960501

**Magl<sup>3</sup>C** Power Module  
**VDMM** – Variable Step Down MicroModule



## ELECTRICAL SPECIFICATIONS

MIN and MAX limits are valid for the recommended ambient temperature range of **-40°C to 85°C**. Typical values represents statistically the utmost probable values at the following conditions:  $V_{IN} = 5V$ ,  $V_{OUT} = 1.8V$ ,  $C_{IN} = C_{OUT} = 10\mu F$  ceramic, unless otherwise noted.

SYMBOL	PARAMETER	TEST CONDITIONS	MIN <sup>(1)</sup>	TYP <sup>(2)</sup>	MAX <sup>(1)</sup>	UNIT
<b>Efficiency</b>						
$\eta$	Efficiency	$V_{IN} = 3.6V$ , $V_{OUT} = 1.8V$ , $I_{OUT} = 50mA$ MODE = low	-	90	-	%
		$V_{IN} = 5V$ , $V_{OUT} = 3.3V$ , $I_{OUT} = 50mA$ MODE = low	-	90	-	%
		$V_{IN} = 3.6V$ , $V_{OUT} = 1.8V$ , $I_{OUT} = 200mA$ , MODE = high	-	91	-	%
		$V_{IN} = 5V$ , $V_{OUT} = 3.3V$ , $I_{OUT} = 200mA$ , MODE = high	-	93	-	%
		$V_{IN} = 3.6V$ , $V_{OUT} = 3.3V$ , $I_{OUT} = 200mA$ , MODE = high	-	96	-	%
<b>Input quiescent/shutdown current</b>						
$I_{SD}$	Shutdown quiescent current	$V_{ENABLE} = 0V$ $T_A = 25^\circ C$	-	0.1	1	$\mu A$
$I_{IN}$	No load input current	MODE = high, EN = high, switching with no load, $V_{OUT} = 1.8V$ , $T_A = 25^\circ C$	-	6	-	mA
		MODE = low, EN = high, switching with no load, $V_{OUT} = 1.8V$ , $T_A = 25^\circ C$	-	3	-	mA
$I_Q$	Quiescent current	MODE = low, EN = high no switching, $T_A = 25^\circ C$	-	30	-	$\mu A$

## RoHS, REACH

RoHS directive		Directive 2011/65/EU of the European Parliament and the Council of June 8th, 2011 on the restriction of the use of certain hazardous substances in electrical and electronic equipment.
REACH directive		Directive 1907/2006/EU of the European Parliament and the Council of June 1st, 2007 regarding the Registration, Evaluation, Authorization and Restriction of Chemicals (REACH).

## PACKAGE SPECIFICATIONS

Weight	Molding compound	UL class	Certificate number
0.047g	None	Not applicable	Not applicable

**WPMDB1960501XF / 171960501**

**MagI<sup>3</sup>C** Power Module  
**VDMM** – Variable Step Down MicroModule

**NOTES**

- (1) Min and Max limits are 100% production tested at 25°C. Limits over the operating temperature range are guaranteed through correlation using Statistical Quality Control (SQC) methods.
- (2) Typical numbers are valid at 25°C ambient temperature and represent statistically the utmost probable values assuming a Gaussian distribution.
- (3) Depending on heat sink design, number of PCB layers, copper thickness and air flow.
- (4) Measured on a 101.5 x 114.5 mm one layer board, with 70µm (2 ounce) copper, no air flow, according to JESD51-9.
- (5) The industry standard for comparison of the output voltage ripple between switching regulators or modules requires a 10µF ceramic (sometimes additional 1µF ceramic in parallel) at the point of load where the voltage measurement is done using an oscilloscope with its probe and probe jack designed for low voltage/high frequency (low impedance) measurement. The oscilloscopes bandwidth is limited at 20MHz.

# WPMDB1960501XF / 171960501

**MagI<sup>3</sup>C** Power Module  
**VDMM** – Variable Step Down MicroModule



## TYPICAL PERFORMANCE CURVES

If not otherwise specified, the following conditions apply:  $V_{IN} = 5V$ ;  $C_{IN} = 10\mu F$  X7R ceramic;  $C_{OUT} = 10\mu F$  X7R ceramic,  $C_{FF} = 22pF$ ,  $T_{AMB} = 25^{\circ}C$ .

## RADIATED EMISSIONS EN55022 (CISPR-22) CLASS B COMPLIANT

Measured with module on Eval Board 178960501 at 3m antenna distance.

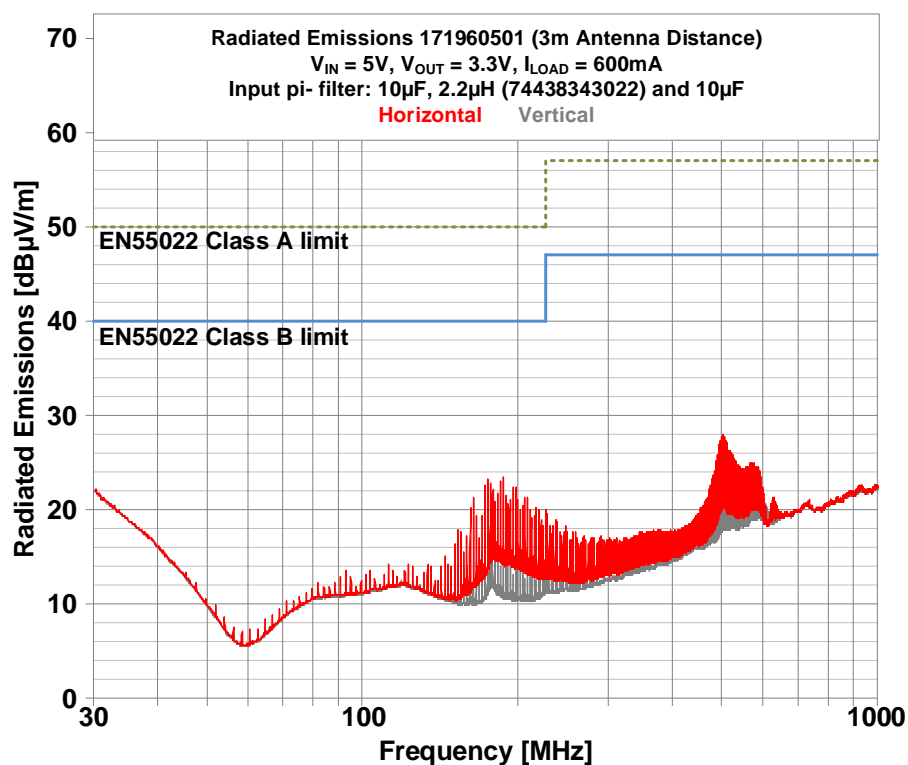

The diagram above refers only to forced PWM mode. Nevertheless similar results would be obtained in PFM/PWM mode because at this load current (600mA) there is no difference between the two modes.



WPMDB1960501XF / 171960501

**Magl<sup>3</sup>C** Power Module  
**VDMM** – Variable Step Down MicroModule



**EFFICIENCY**

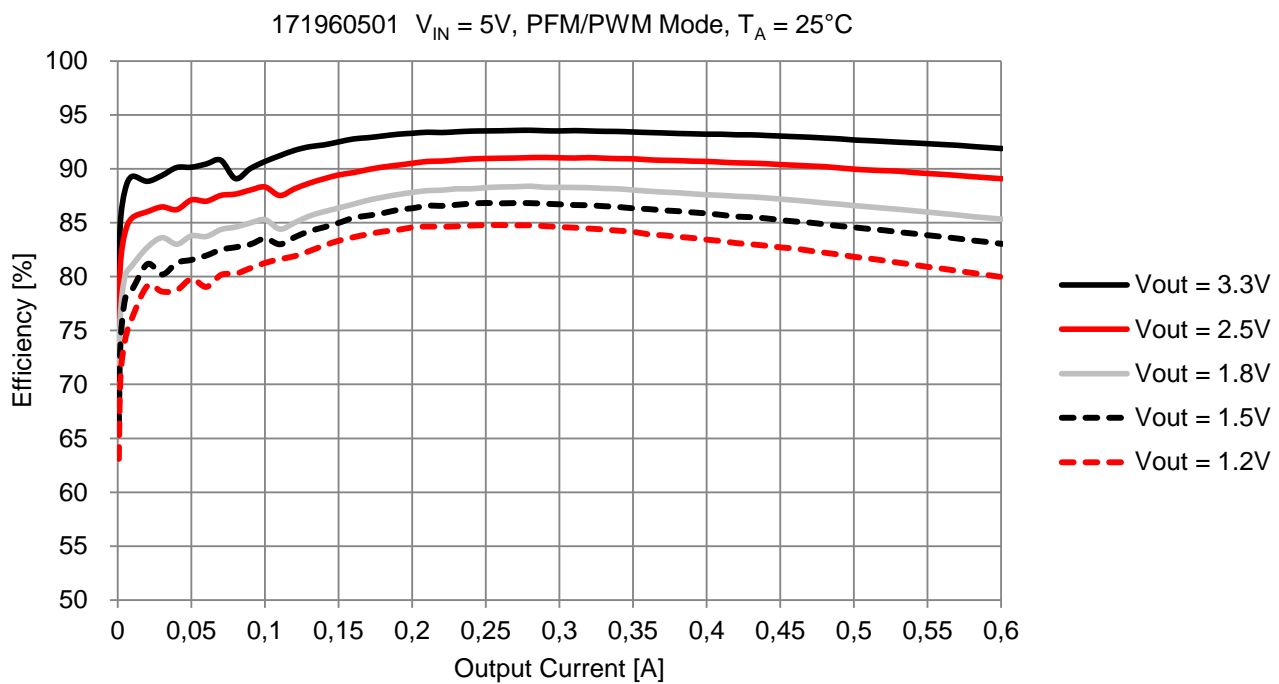
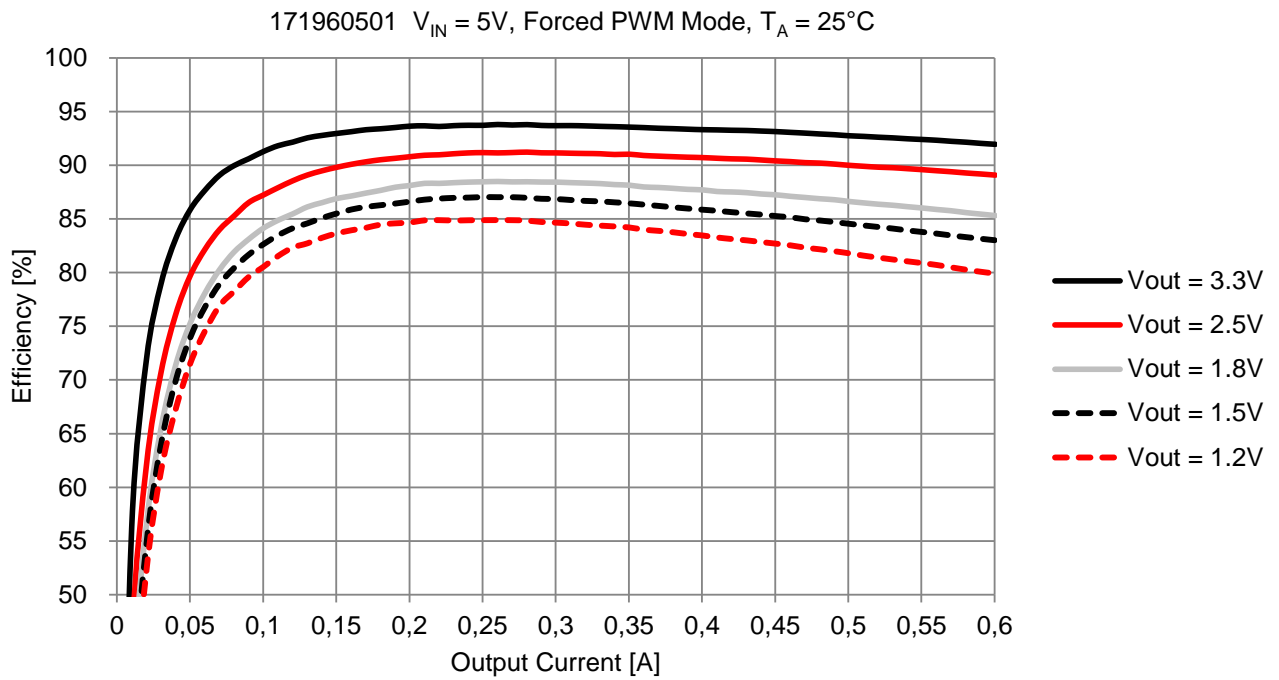

WPMDB1960501XF / 171960501

MagI<sup>3</sup>C Power Module  
 VDMM – Variable Step Down MicroModule



EFFICIENCY

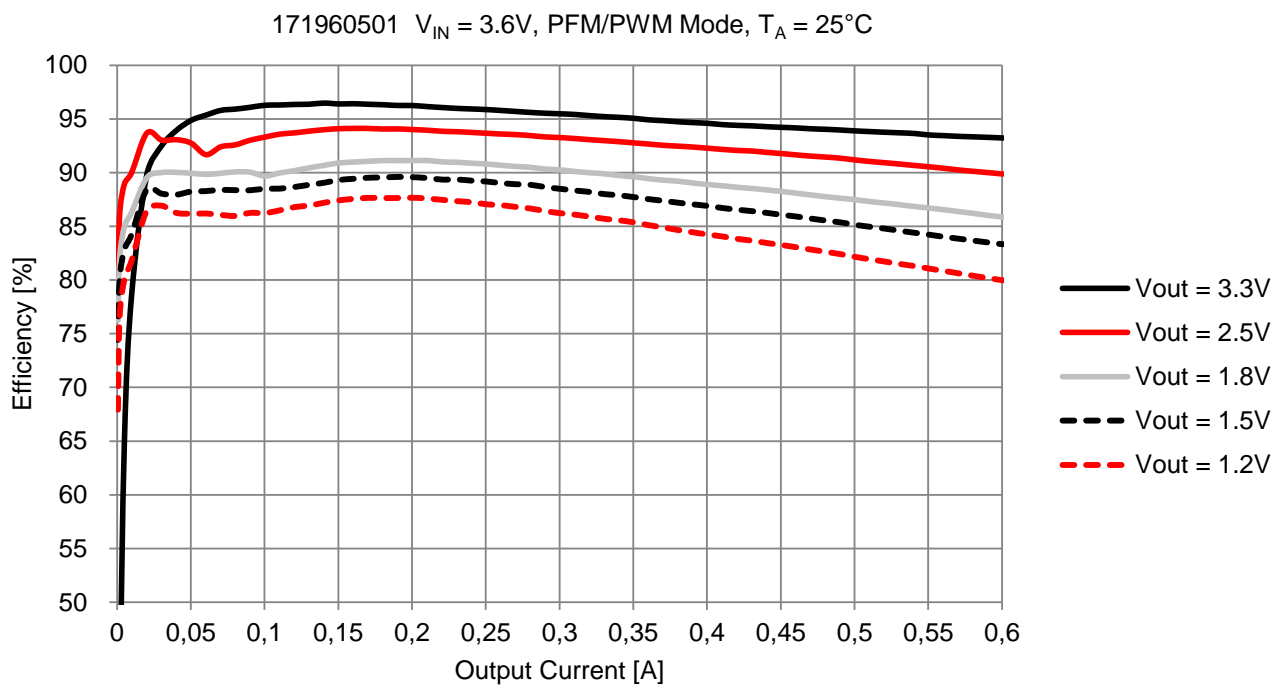
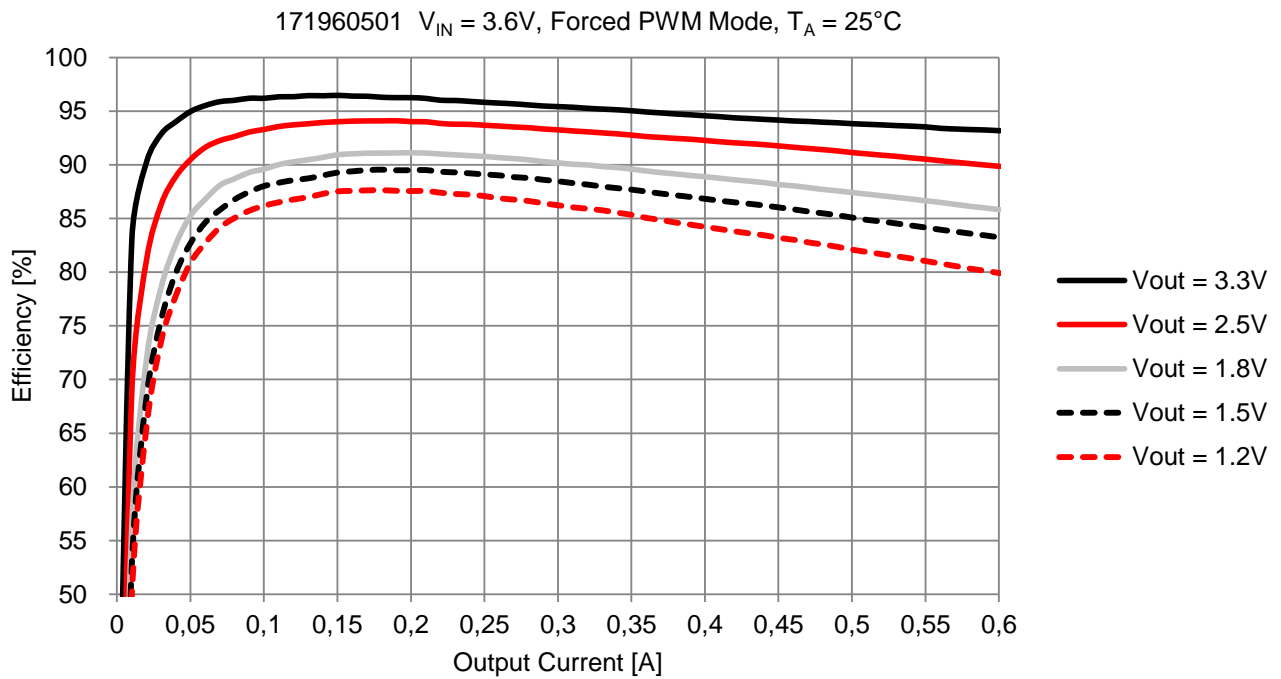

WPMDB1960501XF / 171960501

**MagI<sup>3</sup>C** Power Module  
**VDMM** – Variable Step Down MicroModule



**EFFICIENCY**

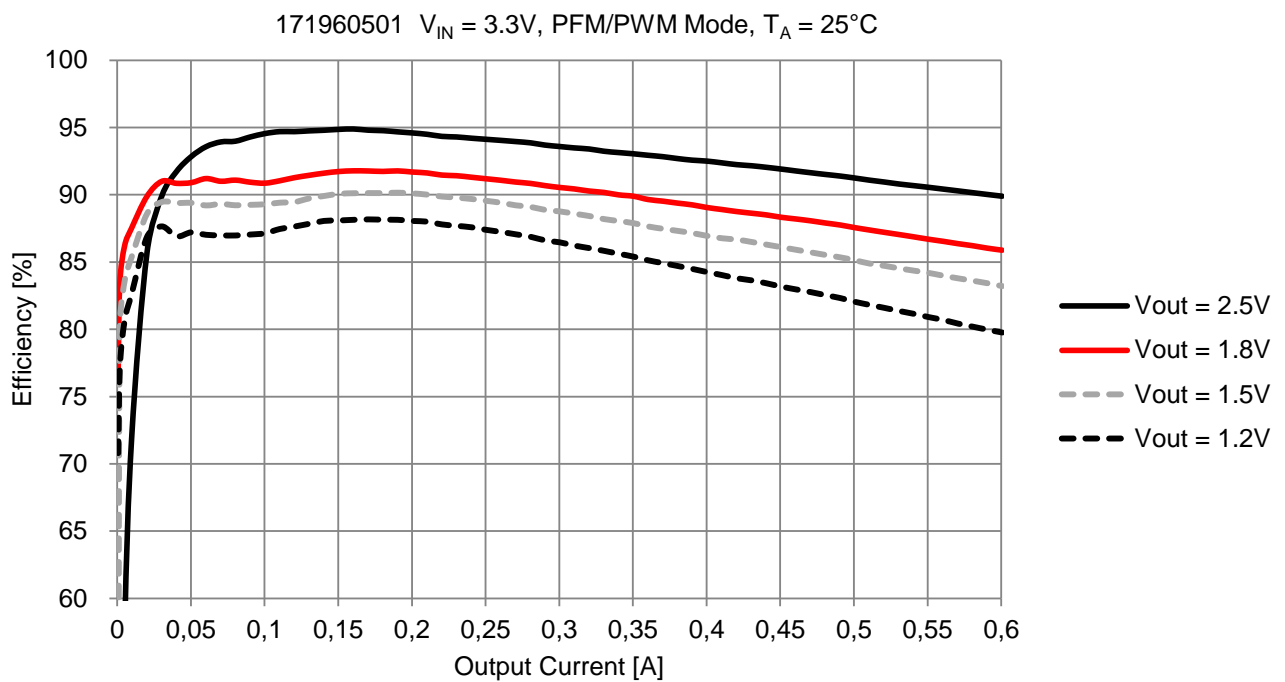
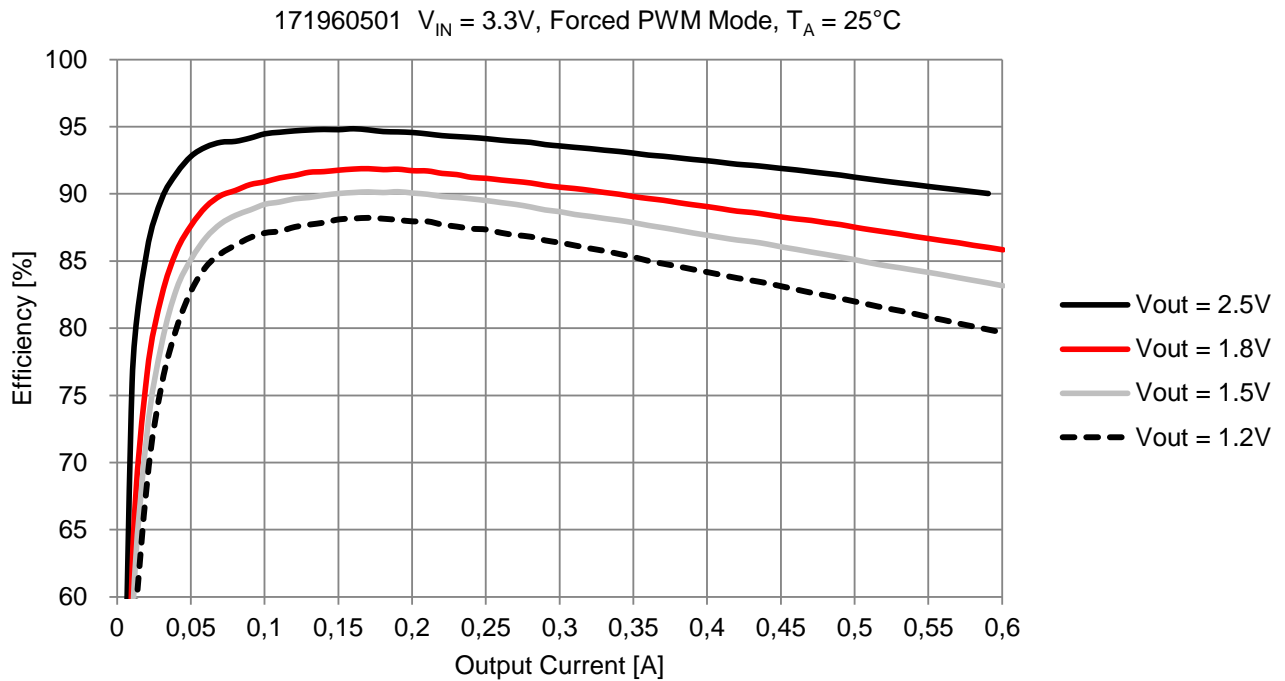

WPMDB1960501XF / 171960501

Mag<sup>3</sup>C Power Module  
 VDMM – Variable Step Down MicroModule



POWER DISSIPATION

171960501  $V_{IN} = 5V$ , Forced PWM Mode,  $T_A = 25^\circ C$

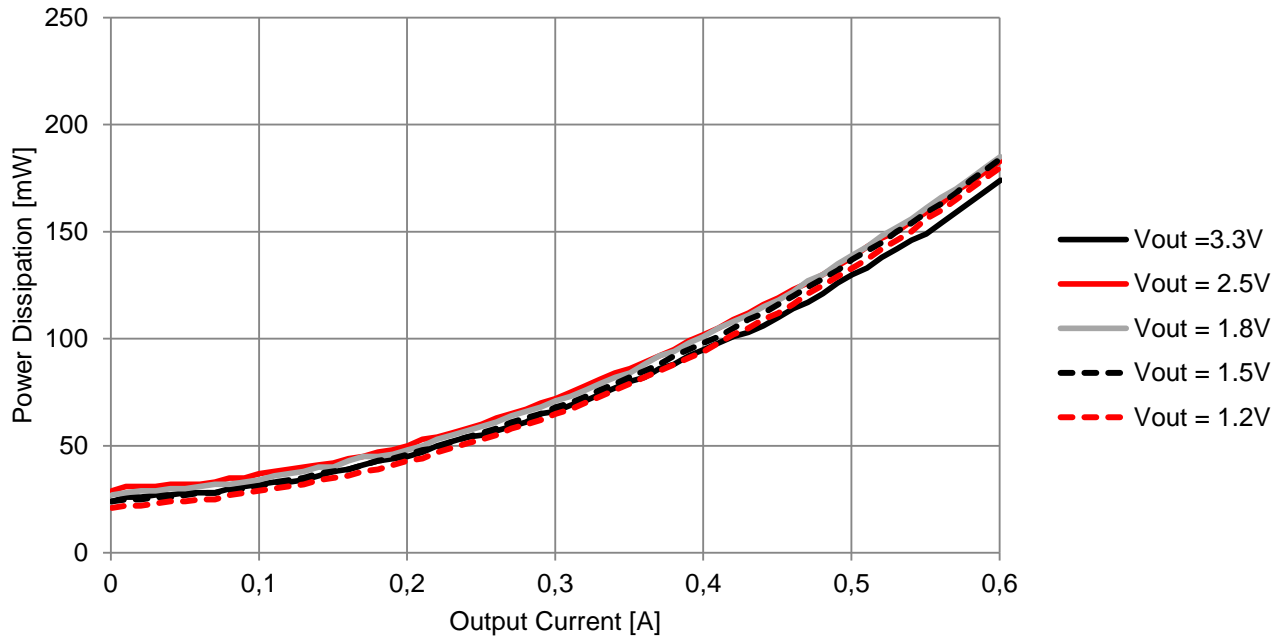

171960501  $V_{IN} = 5V$ , PFM/PWM Mode,  $T_A = 25^\circ C$

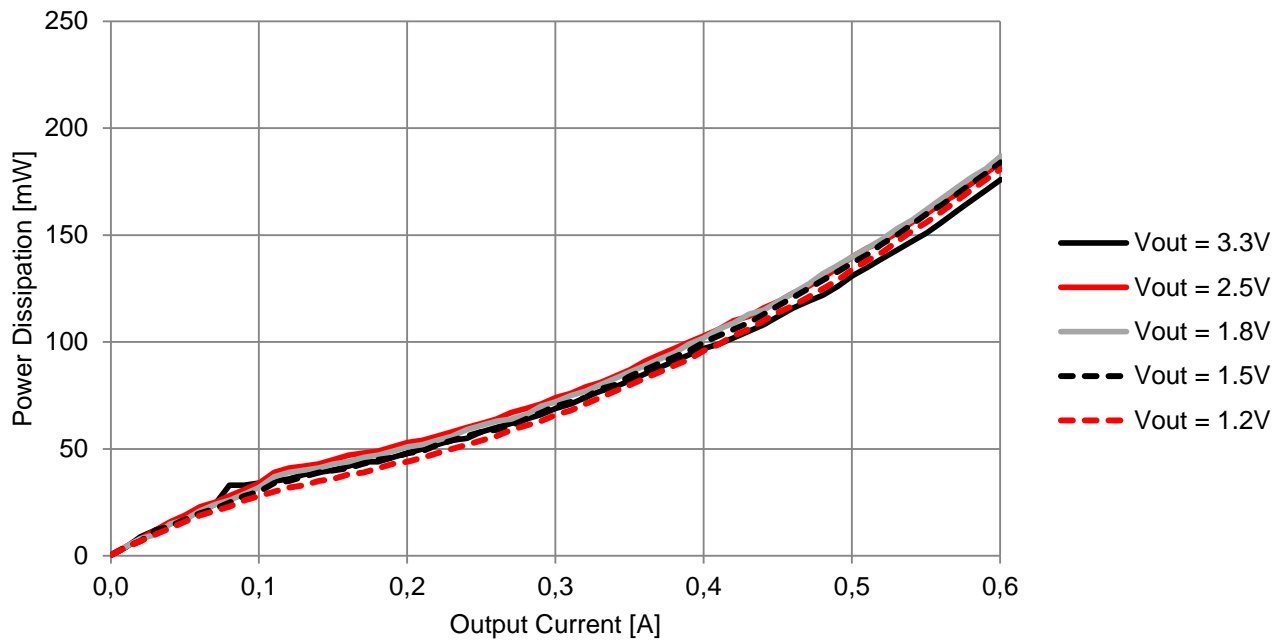

WPMDB1960501XF / 171960501

Mag<sup>3</sup>C Power Module  
 VDMM – Variable Step Down MicroModule



POWER CONSUMPTION

171960501  $V_{IN} = 3.6V$ , Forced PWM Mode,  $T_A = 25^\circ C$

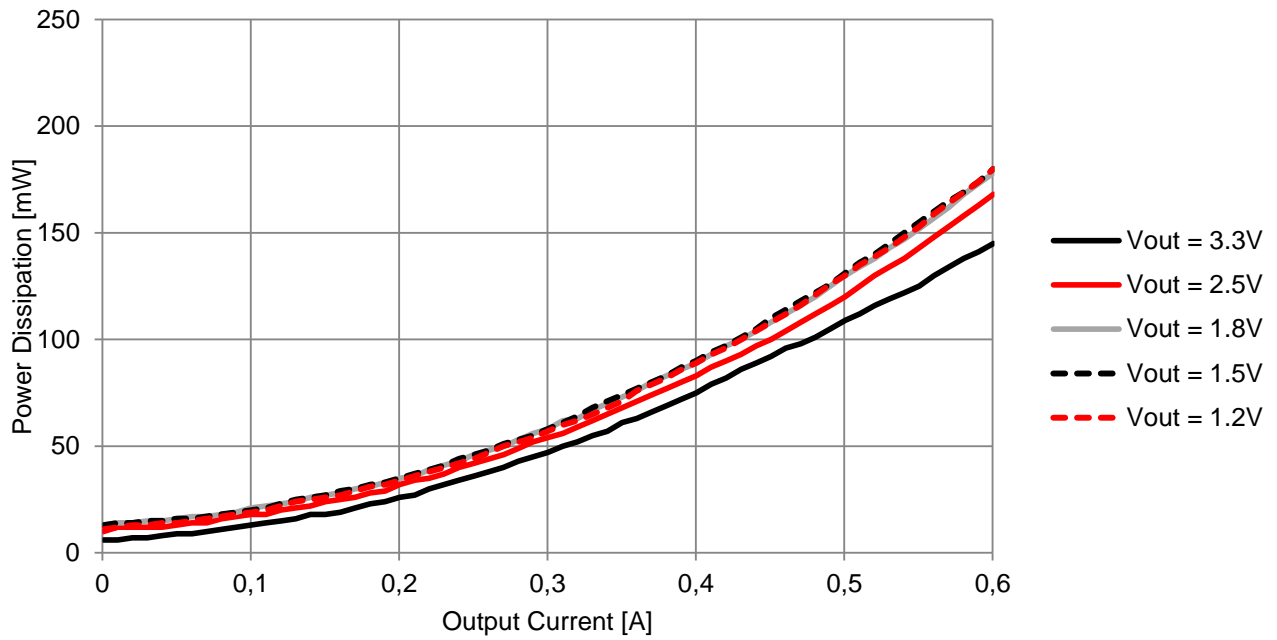

171960501  $V_{IN} = 3.6V$ , PFM/PWM Mode,  $T_A = 25^\circ C$

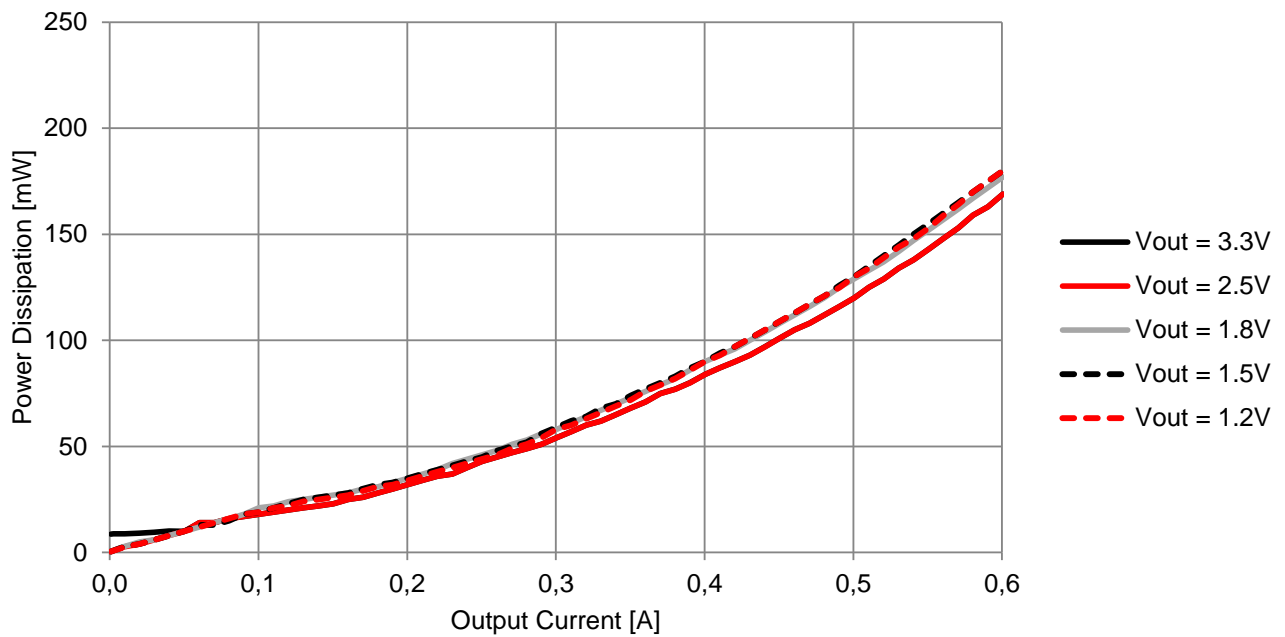

# WPMDB1960501XF / 171960501

**MagI<sup>3</sup>C** Power Module  
**VDMM** – Variable Step Down MicroModule



## POWER CONSUMPTION

171960501  $V_{IN} = 3.3V$ , Forced PWM Mode,  $T_A = 25^\circ C$

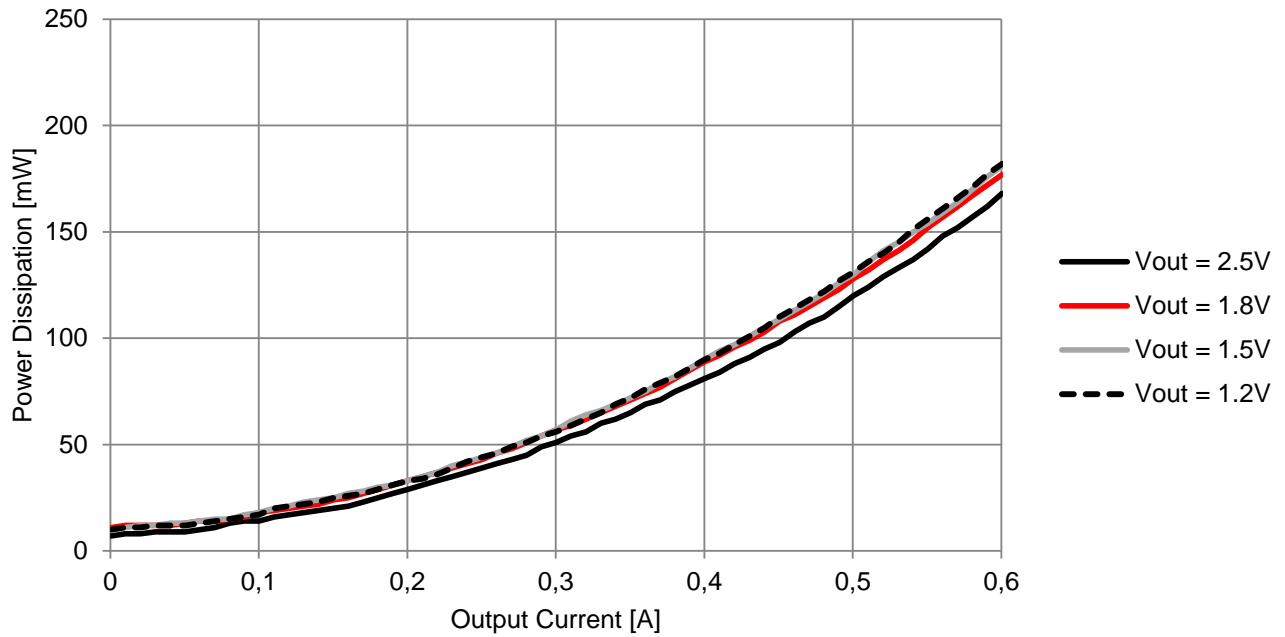

171960501  $V_{IN} = 3.3V$ , PFM/PWM Mode,  $T_A = 25^\circ C$

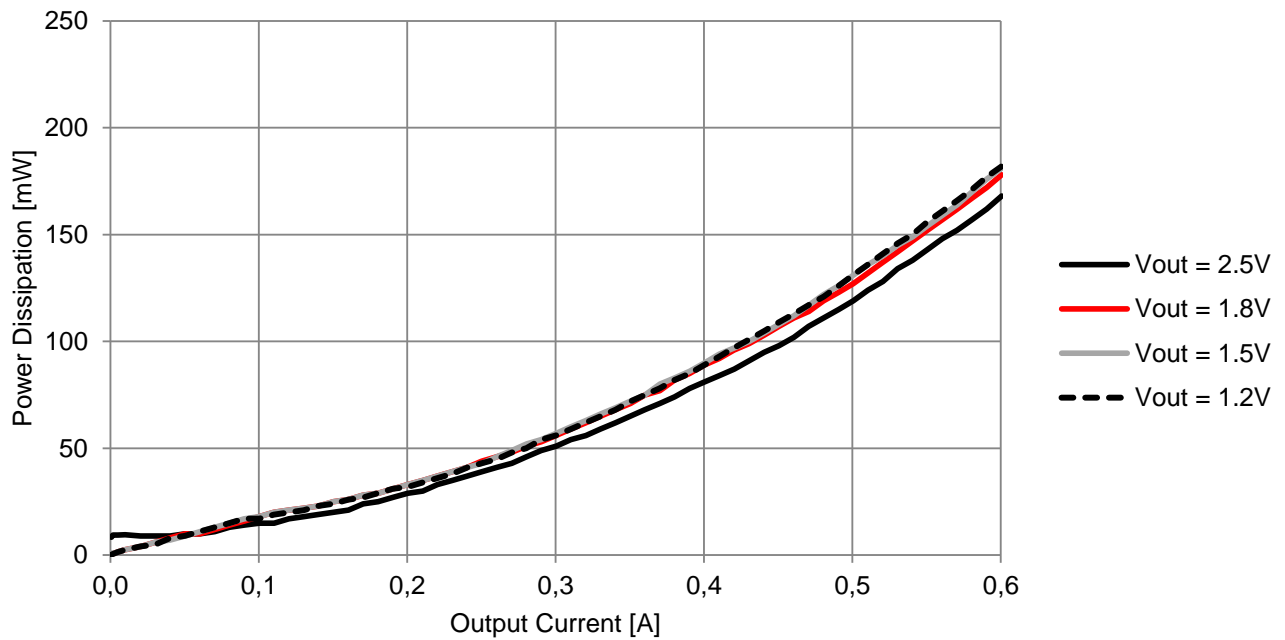

WPMDB1960501XF / 171960501

**MagI<sup>3</sup>C** Power Module  
**VDMM** – Variable Step Down MicroModule



**OUTPUT POWER DERATING**

171960501 Current Thermal Derating  
 $V_{IN} = 3.6V, V_{OUT} = 1.8V, \text{PFM/PWM Mode, } \theta_{JA} = 150^{\circ}\text{C/W}$

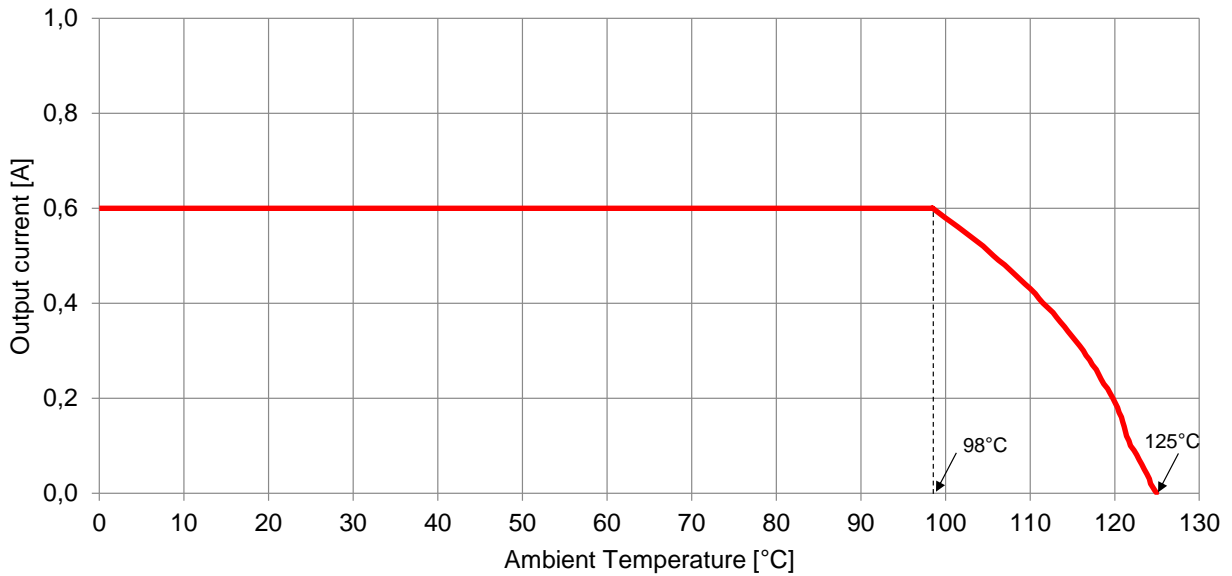

171960501 Current Thermal Derating  
 $V_{IN} = 5V, V_{OUT} = 3.3V, \text{PFM/PWM Mode, } \theta_{JA} = 150^{\circ}\text{C/W}$

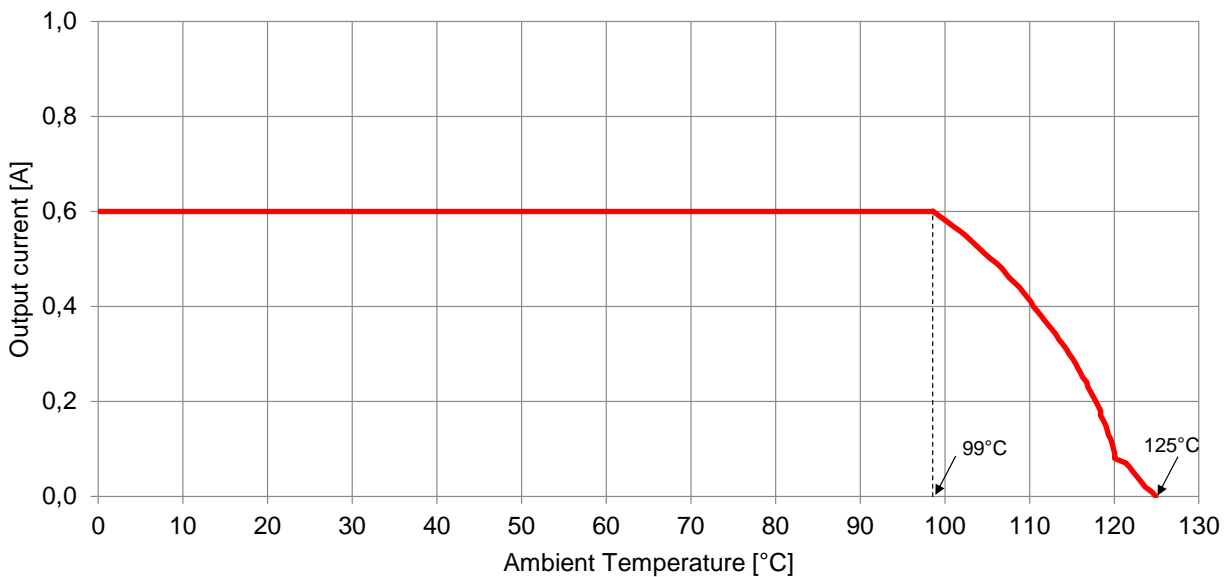

Note : see T<sub>A</sub> limits in [Operating Conditions](#) on page 4.

# WPMDB1960501XF / 171960501

**Magl<sup>3</sup>C** Power Module  
**VDMM** – Variable Step Down MicroModule



## LOAD REGULATION

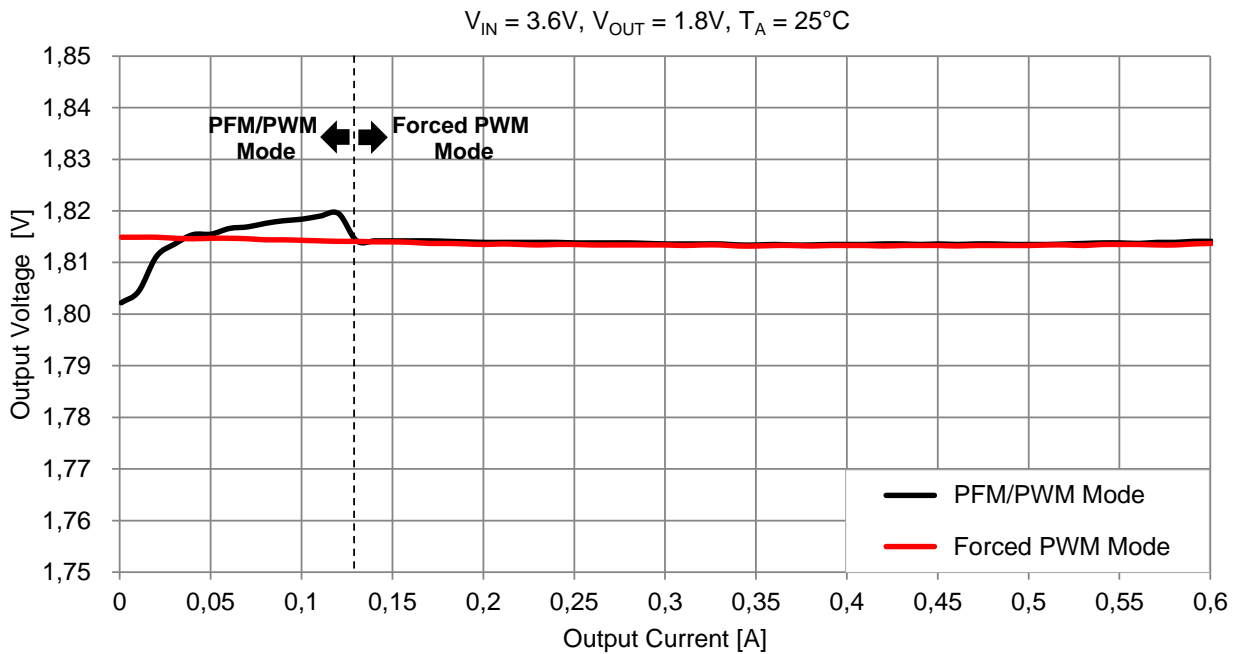

## LINE REGULATION

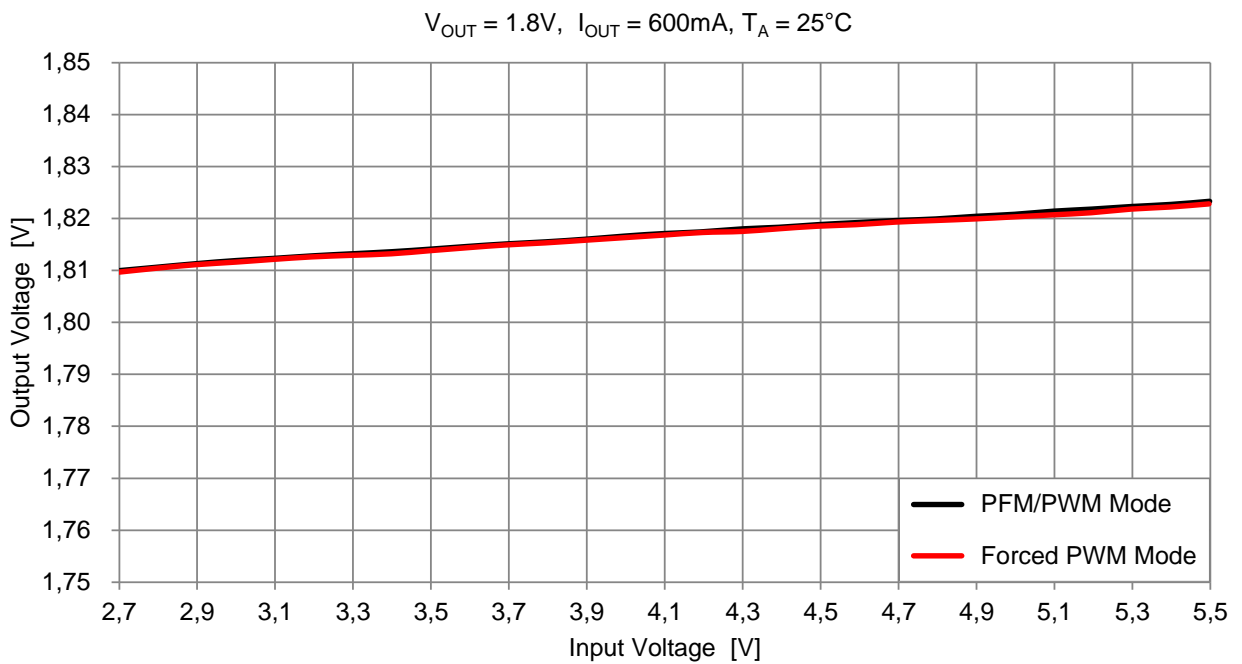



# WPMDB1960501XF / 171960501

**MagI<sup>3</sup>C** Power Module  
**VDMM** – Variable Step Down MicroModule



## BLOCK DIAGRAM

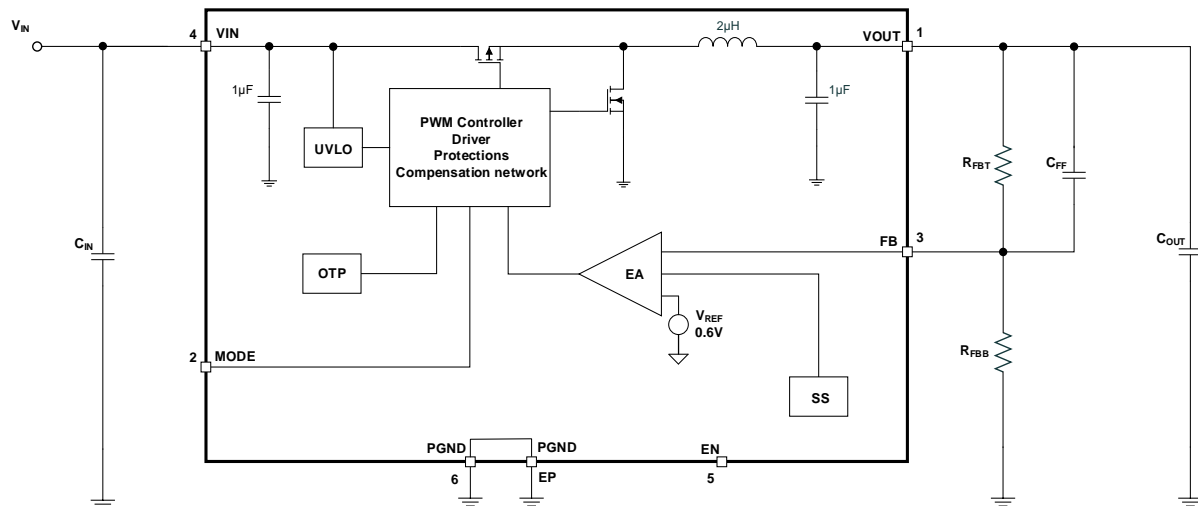

## CIRCUIT DESCRIPTION

The MagI<sup>3</sup>C MicroModule 171960501 is based on a synchronous step down regulator with integrated MOSFETs and a power inductor. The control scheme is based on a Voltage Mode (VM) regulation loop.

Through the external resistor divider, a voltage proportional to  $V_{OUT}$  is fed to the FB pin of the MicroModule. This voltage is then compared with an internal reference (0.6V). The signal resulting from this comparison is then used to drive the two power MOSFETs in accordance with the status of the MODE pin. When the Forced PWM mode is selected the switching frequency always remains constant at 2.25 MHz.

# WPMDB1960501XF / 171960501

**MagI<sup>3</sup>C** Power Module  
**VDMM** – Variable Step Down MicroModule



## DESIGN FLOW

The next four simple steps will show how to select the external components to design the 171960501 application.

### Essential Steps

1. Set output voltage
2. Select input capacitor
3. Select output capacitor
4. Select the feed-forward capacitor

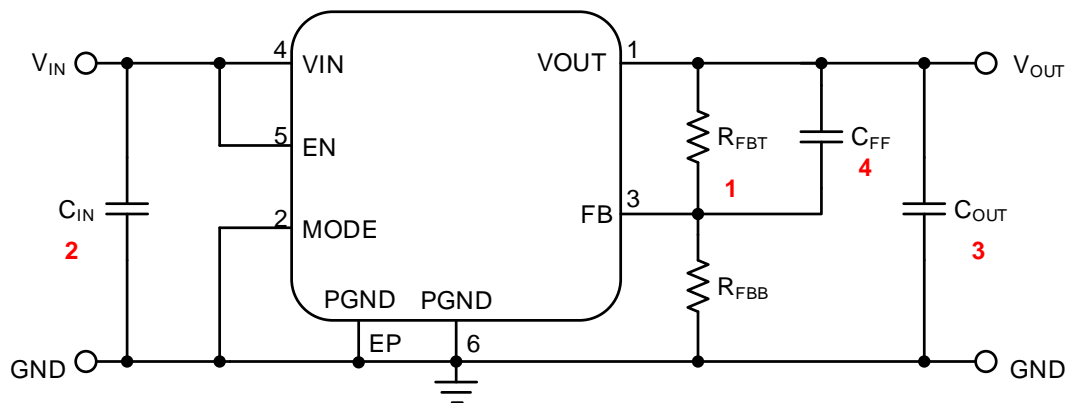

# WPMDB1960501XF / 171960501

**MagI<sup>3</sup>C** Power Module  
**VDMM** – Variable Step Down MicroModule



## Step 1 Setting the output voltage ( $V_{OUT}$ )

The output voltage is selected with an external resistor divider between  $V_{OUT}$  and GND (see circuit below). The voltage across the lower resistor of the divider is provided to the FB pin. The output voltage adjustment range is from 0.6V to 5.5V. The output voltage can be calculated according to the following formula:

$$V_{OUT} = V_{FB} \cdot \left( \frac{R_{FBT}}{R_{FBB}} + 1 \right)$$

One resistor must be chosen and then the other resistor can be calculated. For example, if  $R_{FBT} = 100\text{k}\Omega$  then the resistance value of the lower resistor in the feedback network is indicated in the table below for common output voltages.

$V_{OUT}$	1.2V	1.5V	1.8V	2.5V	3.3V	3.6 V	4.2V
$R_{FBB}$ (E96)	100k $\Omega$	66.5k $\Omega$	49.9k $\Omega$	31.6k $\Omega$	22.1k $\Omega$	20k $\Omega$	16.5k $\Omega$

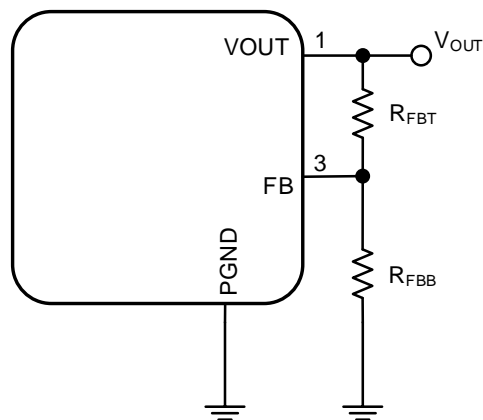

**WPMDB1960501XF / 171960501****MagI<sup>3</sup>C** Power Module  
**VDMM** – Variable Step Down MicroModule**Step 2 Select input capacitor (C<sub>IN</sub>)**

The energy at the input of the MicroModule is stored in the input capacitor. An input capacitor (1µF) is integrated inside the 171960501 MagI<sup>3</sup>C MicroModule, ensuring good EMI performance and helping protect against possible voltage spikes. Additional input capacitance is required externally to provide cycle-by-cycle switch current and to support load transients. The external input capacitor must be placed directly at the VIN pin. For this MagI<sup>3</sup>C MicroModule it is recommended to use a MLCC (Mutli Layer Ceramic Capacitor) of 10µF. Attention must be paid to the voltage and temperature deratings of the selected capacitor.

**Step 3 Select output capacitor (C<sub>OUT</sub>)**

The output capacitor should be selected in order to minimize the output voltage ripple and to provide a stable voltage at the output. It also affects the loop stability. An output capacitor of 1µF is integrated inside the 171960501 MagI<sup>3</sup>C MicroModule. An external MLCC of 10µF is recommended for all application conditions. Attention must be paid to the voltage and temperature deratings of the selected capacitor.

In general, the output voltage ripple can be calculated using the following equation:

$$V_{\text{OUT ripple}} = \Delta I_L \cdot \text{ESR} + \Delta I_L \cdot \frac{1}{8 \cdot f_{\text{SW}} \cdot C_{\text{OUT}}} \quad (1)$$

where  $\Delta I_L$  is the inductor current ripple and can be calculated with the following equation:

$$\Delta I_L = \frac{V_{\text{OUT}} \cdot (V_{\text{IN}} - V_{\text{OUT}})}{f_{\text{SW}} \cdot L \cdot V_{\text{IN}}} \quad (2)$$

**Example**

In the section [OUTPUT VOLTAGE RIPPLE](#) on page 25 a ripple measurement is shown under the following conditions:

$$V_{\text{IN}} = 3.6\text{V}$$

$$V_{\text{OUT}} = 1.8\text{V}$$

$$L = 2\mu\text{H}$$

$$f_{\text{SW}} = 2.25\text{MHz}$$

$$C_{\text{OUT}} = 10\mu\text{F (external, Würth Elektronik, part number 885012107014)} + 1\mu\text{F (internal)} = 11\mu\text{F}$$

Assuming a reduction of the capacitance of about 10% due to the bias voltage, a remaining capacitance of around 10µF can be considered. Another assumption can be done for the ESR, which can be considered lower than 5mΩ.

Using equations (1) and (2), the expected ripple is  $V_{\text{OUT ripple}} \leq 2\text{mV}$ , which matches the results obtained with the measurement.

# WPMDB1960501XF / 171960501

**MagI<sup>3</sup>C** Power Module  
**VDMM** – Variable Step Down MicroModule



## Step 4 Select the feed-forward capacitor ( $C_{FF}$ )

For the 171960501 MagI<sup>3</sup>C MicroModule a feedforward capacitor  $C_{FF}$  is normally recommended to improve the stability and to broaden the bandwidth, which leads to a faster load transient response. A value of 22pF has been practically evaluated as the best performing.

The pictures below show the load transient response of the 171960501 to a load transition from no load to full load using the recommended  $C_{FF} = 22\text{pF}$  as well as higher values of  $C_{FF}$ . A higher value of  $C_{FF}$  helps to reduce the overshoot and undershoot just after the current step and provide a faster reaction to the load transient.

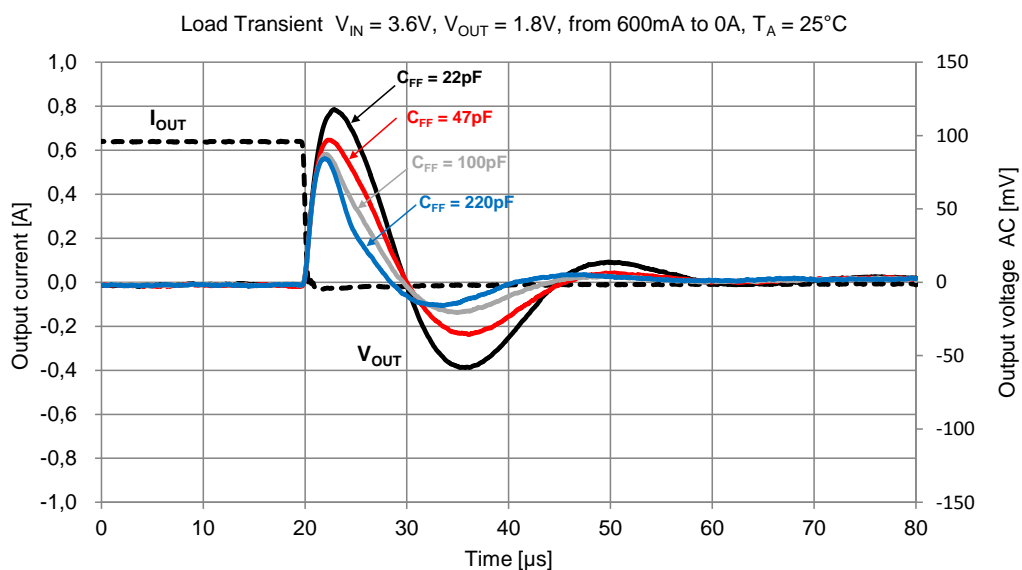
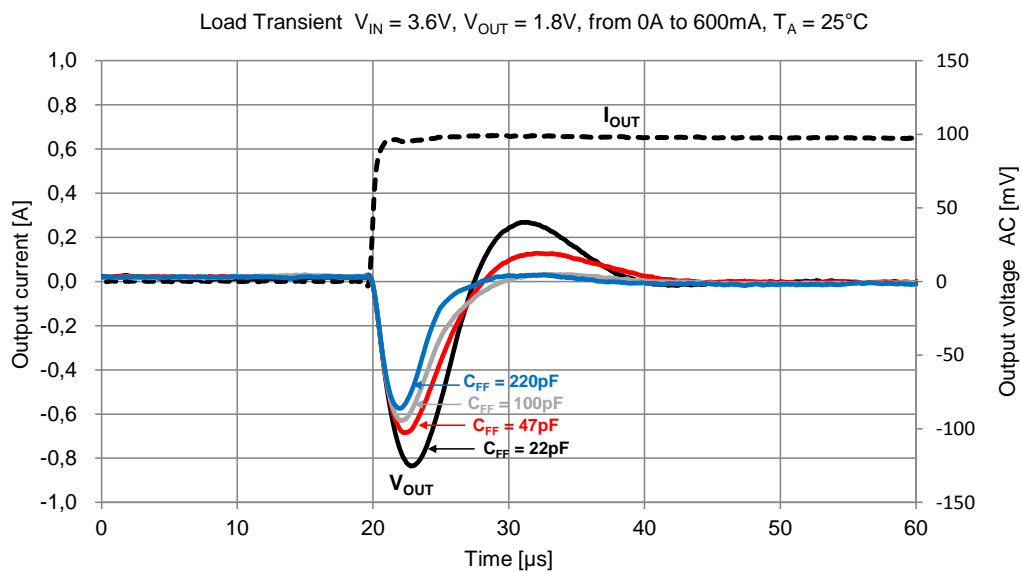

# WPMDB1960501XF / 171960501

**MagI<sup>3</sup>C** Power Module  
**VDMM** – Variable Step Down MicroModule



The use of a higher value of  $C_{FF}$  not only influences the load transient response but also affects the efficiency under light load conditions when the PFM/PWM mode is selected.

As explained in the section [LIGHT LOAD OPERATION](#) on page 23, under light load operation and PFM/PWM Mode, the device does not continuously switch, instead delivering energy to the load in bursts. The frequency of those bursts is influenced by the value of  $C_{FF}$  (see below), among other parameters (more details in the dedicated section).

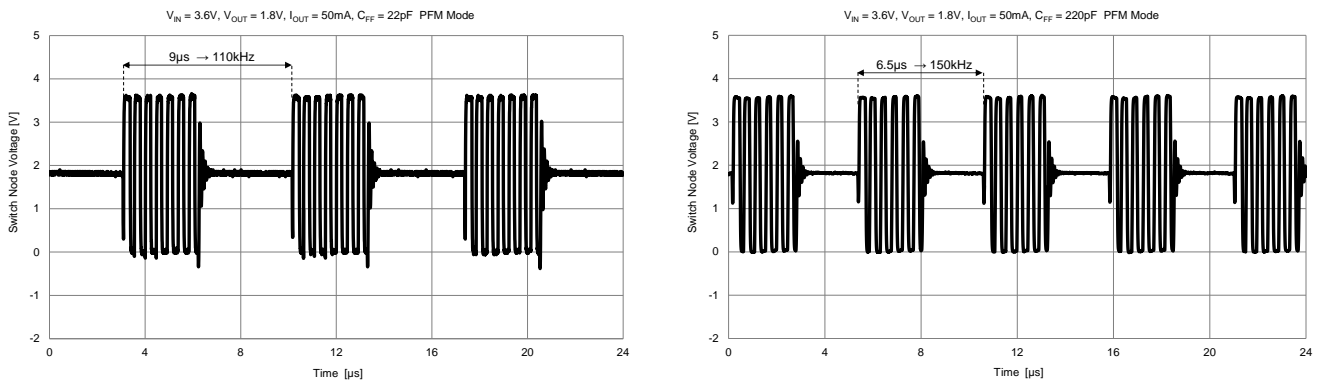

Increasing  $C_{FF}$  will cause the module to burst more often resulting in a decrease in efficiency, as depicted in the diagram below.

A trade-off between load step response and efficiency should be considered while selecting the most suitable value for  $C_{FF}$ .

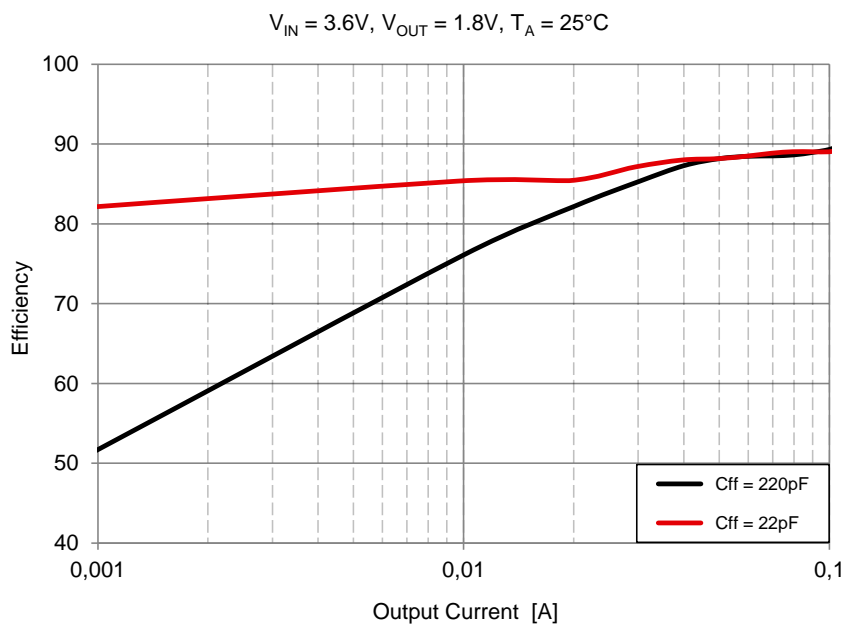

# WPMDB1960501XF / 171960501

**MagI<sup>3</sup>C** Power Module  
**VDMM** – Variable Step Down MicroModule



## LIGHT LOAD OPERATION

Under light load conditions the 171960501 behaves differently according to the MODE pin setting.

### Forced PWM mode

Pulling the MODE pin high selects the forced PWM mode. In this mode the device constantly functions in PWM mode, switching at the default 2.25 MHz fixed switching frequency, independently of the load (see figure below). This mode of operation eases the filtering requirements to help with noise sensitive applications.

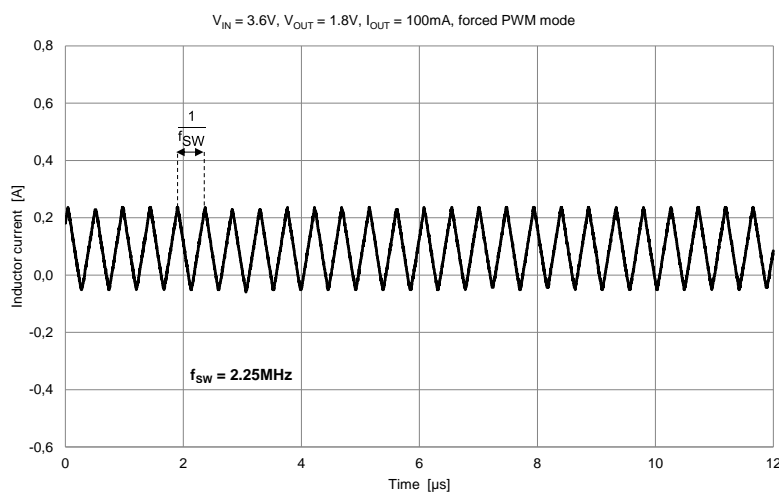

### PFM/PWM mode

Setting the MODE pin low selects the PFM/PWM mode. This mode achieves a much higher efficiency at light loads (normally below 100mA), as shown in the picture below.

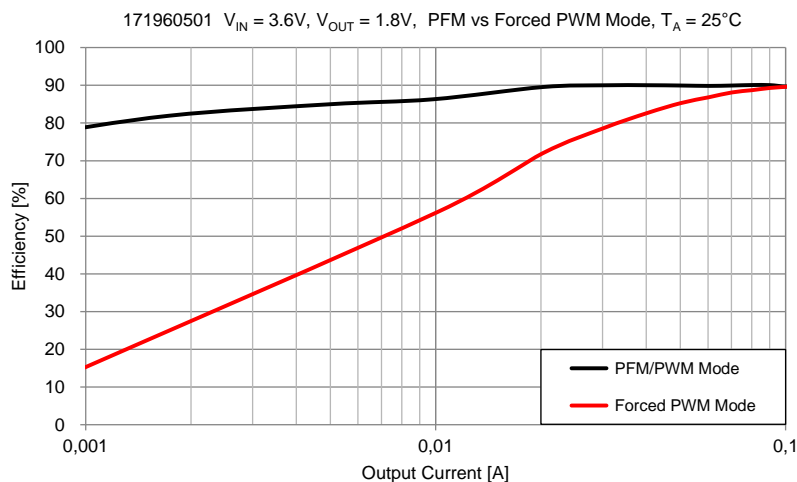

## WPMDB1960501XF / 171960501

**MagI<sup>3</sup>C** Power Module  
**VDMM** – Variable Step Down MicroModule

In PFM/PWM mode the energy is delivered in bursts to the load (see figure below). Within each burst the device switches at the default switching frequency and the energy is delivered to both the load and the output capacitor. Between two bursts, the device does not switch (the load demand is supported by the output capacitor) and the current consumption is significantly reduced, leading to higher efficiency compared to the forced PWM mode. The frequency of the bursts ( $f_{burst}$ ) depends on the load and it is much lower than the default switching frequency (see picture below at two different load conditions). When the load current is above 100mA, the transition from the PFM mode to the PWM mode takes place automatically.

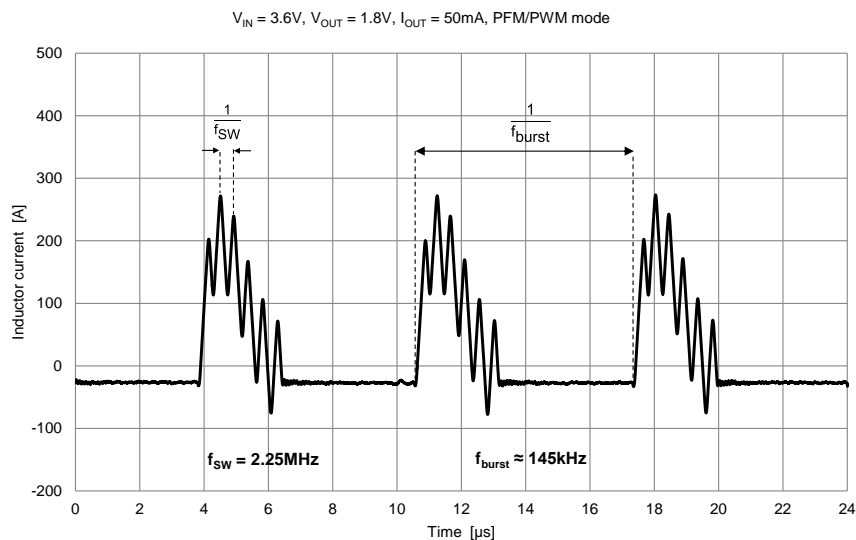
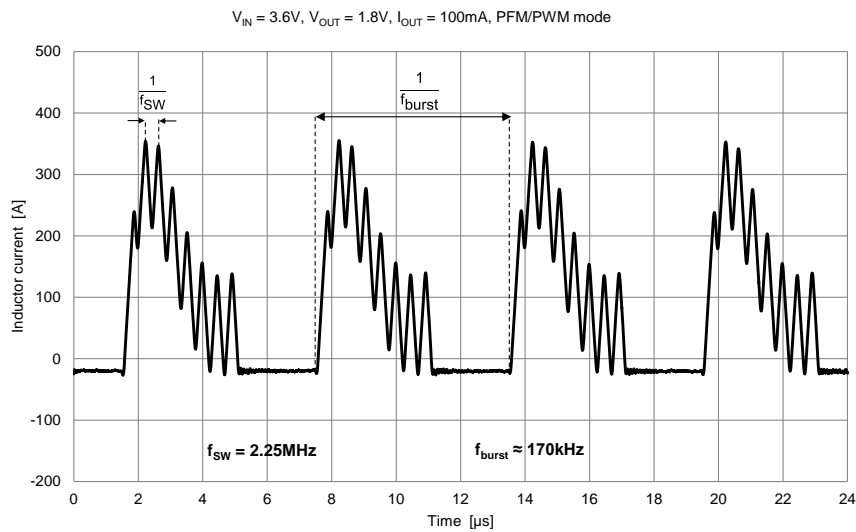

Please consider that the burst frequency  $f_{burst}$  can differ from the example measurements above depending on several parameters (e.g.  $C_{OUT}$ ,  $C_{FF}$ , etc.).



# WPMDB1960501XF / 171960501

**MagI<sup>3</sup>C** Power Module  
**VDMM** – Variable Step Down MicroModule



## OUTPUT VOLTAGE RIPPLE

The output voltage ripple is also influenced by the selection of the MODE pin. If the forced PWM mode is selected, the ripple is very low and it always has the same frequency as the internal oscillator (2.25 MHz). If the PFM/PWM mode is selected, the output voltage ripple is higher and the frequency is lower than the nominal switching frequency (see pictures below).

### Ripple in forced PWM mode

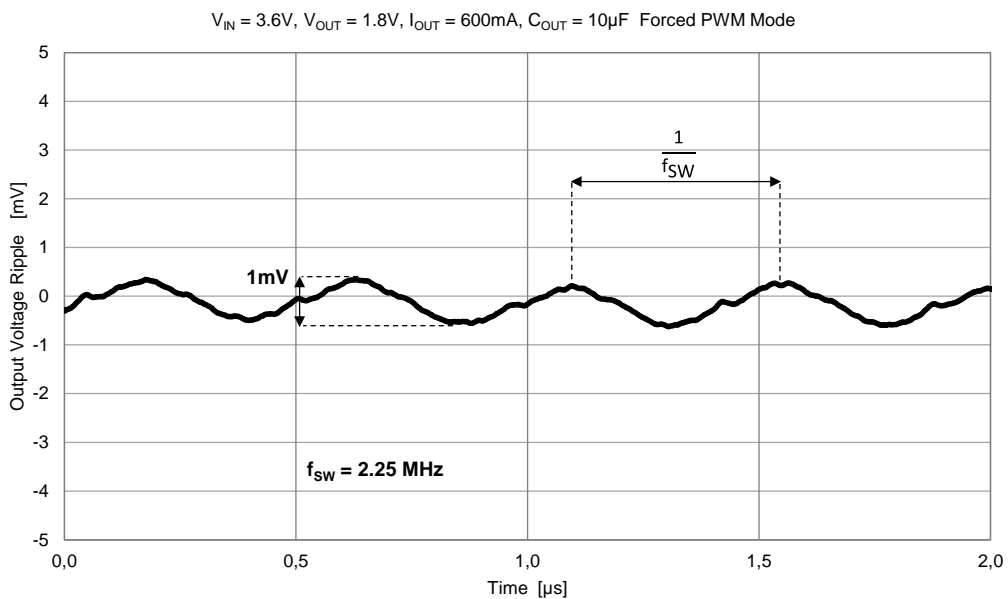

### Ripple in PFM/PWM mode

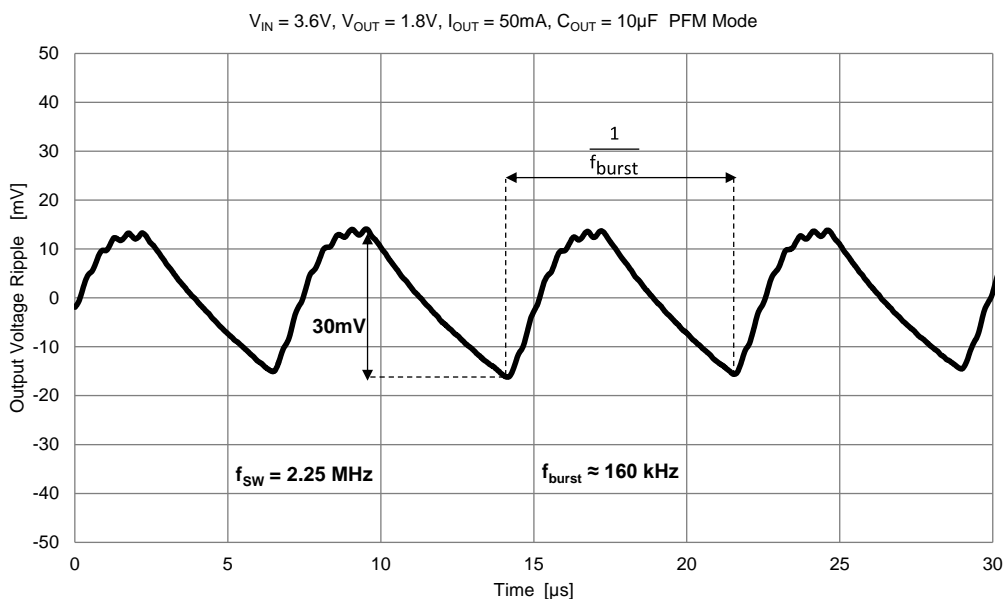

# WPMDB1960501XF / 171960501

**MagI<sup>3</sup>C** Power Module  
**VDMM** – Variable Step Down MicroModule



## PROTECTIVE FEATURES

### Overcurrent protection (OCP)

For protection against load faults, the MagI<sup>3</sup>C MicroModule incorporates cycle-by-cycle current limiting (see  $I_{OCP}$  in “Electrical Specification” on page 5). During an overcurrent condition the output current is limited and the output voltage drops (see figure below). When the overcurrent condition is removed, the output voltage returns to the nominal voltage.

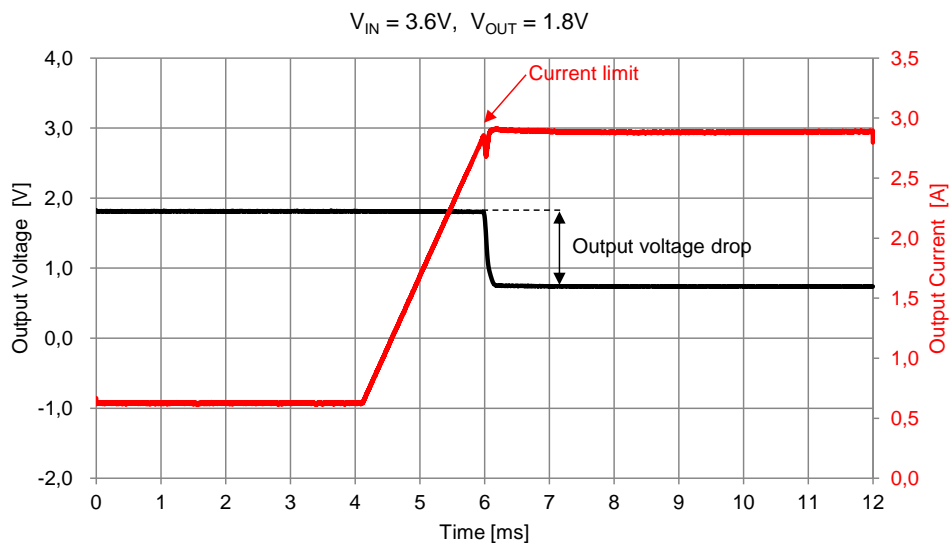

### Short-circuit protection (SCP)

When the MagI<sup>3</sup>C MicroModule experiences a short-circuit condition, it enters a hiccup mode. The MagI<sup>3</sup>C MicroModule reduces the current limit threshold to around 1.5A (typ.) and switches off when this threshold is reached. After that it stays off for a few hundred microseconds and then switches on again with a soft-start. As long as the short-circuit is not cleared, these cycles will continue to repeat (see figure below).

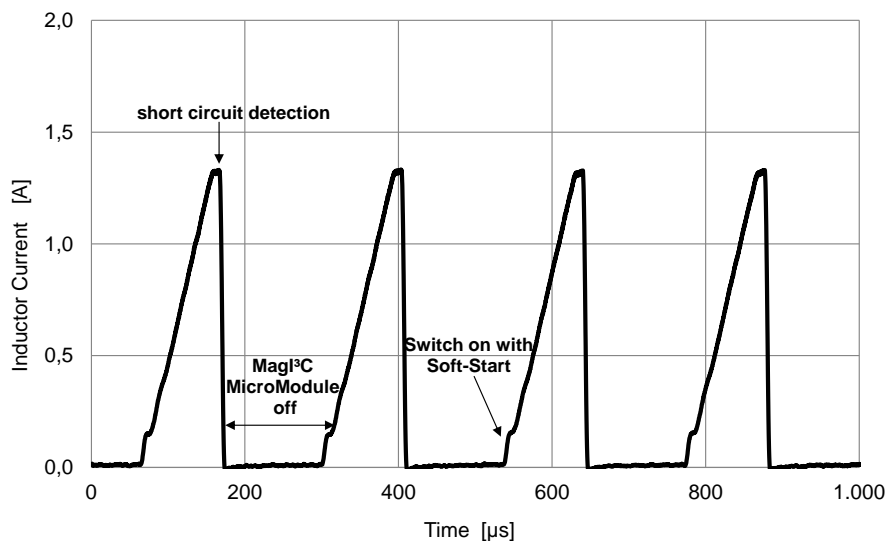

## WPMDB1960501XF / 171960501

**MagI<sup>3</sup>C** Power Module  
**VDMM** – Variable Step Down MicroModule



### Over temperature protection (OTP)

Thermal protection helps prevent catastrophic failures due to accidental device overheating. The junction temperature of the MagI<sup>3</sup>C MicroModule should not be allowed to exceed its maximum ratings. Thermal protection is implemented by an internal thermal shutdown circuit, which activates when the junction temperature reaches 150°C (typ). Under the thermal shutdown condition both MOSFETs remain off causing  $V_{OUT}$  to drop. When the junction temperature falls below 130°C the internal soft-start is released,  $V_{OUT}$  rises smoothly, and normal operation resumes.

### Input undervoltage lockout

The device incorporates undervoltage lockout (UVLO) to protect unexpected behavior at input voltages below the recommended values. The thresholds of the UVLO are indicated in the [Electrical Specifications](#) on page 5.

### Soft-Start

The 171960501 implements an internal soft-start in order to limit the inrush current and avoid output voltage overshoot during start-up. The typical duration of the soft-start is around 550µs (see figure below).

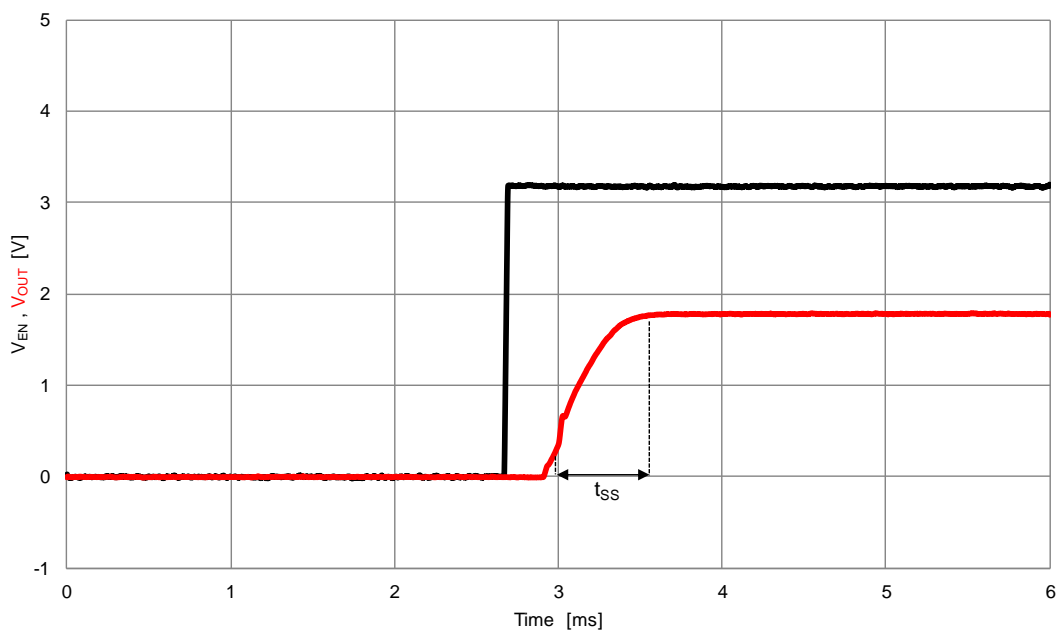

### Enable

The 171960501 MagI<sup>3</sup>C MicroModule is enabled by setting the pin EN high. After setting EN high, the soft-start takes place. The EN pin can be also used to implement power sequencing in systems with various modules, for example connecting the output voltage of another module to the EN pin.

# WPMDB1960501XF / 171960501

**MagI<sup>3</sup>C** Power Module  
**VDMM** – Variable Step Down MicroModule



## LAYOUT RECOMMENDATION

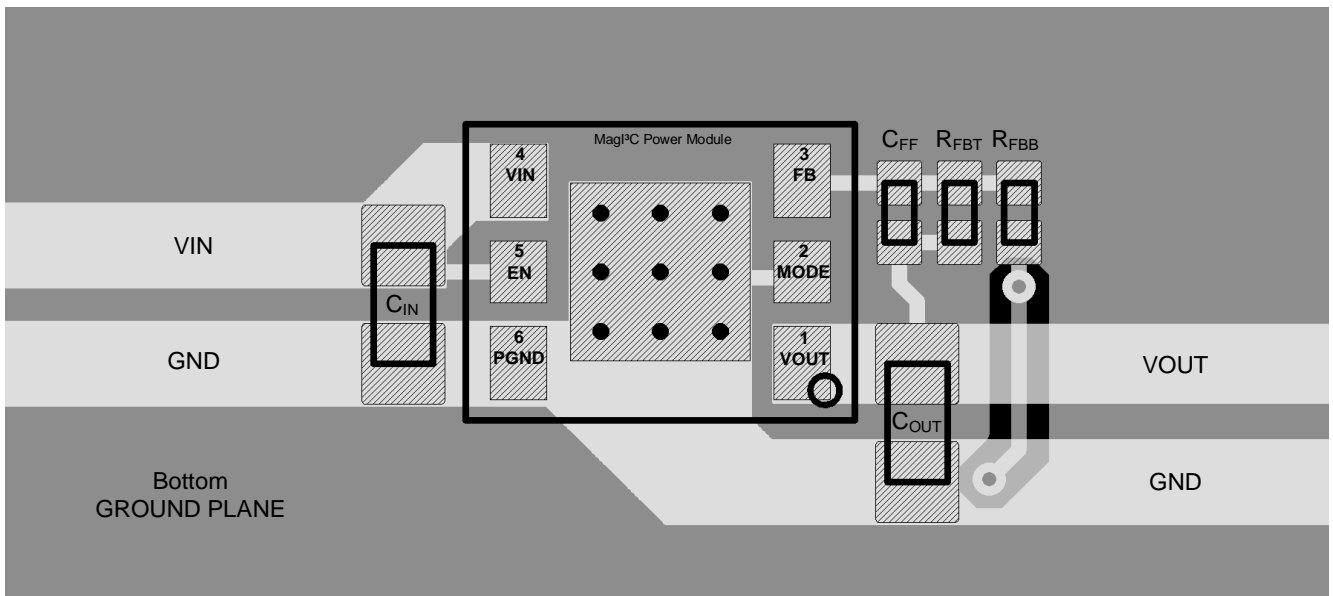

Bottom layer
  Top layer
  Pads

The picture above shows a possible layout for the 171960501 MagI<sup>3</sup>C MicroModule. Nevertheless some recommendation should be followed when a layout is designed:

1. The exposed pads are connected through nine thermal vias to a bottom copper layer for heat dissipation. This copper layer must be not connected with the input GND track nearby the module as this would result in partially bypassing high frequency ripple currents from the input capacitor and generating more EMI.
2. The input and output capacitors should be placed as close as possible to the VIN and VOUT pins of the device.
3. The feedback resistor divider should be placed as close as possible to the FB pin
4. Pins 5 and 2 (EN and MODE respectively) must be always connected to either  $V_{IN}$  or ground and they cannot be left floating (an example is shown in the layout depicted above, where EN and MODE pins are respectively connected to  $V_{IN}$  and ground).

# WPMDB1960501XF / 171960501

**MagI<sup>3</sup>C** Power Module  
**VDMM** – Variable Step Down MicroModule



## EVALUATION BOARD SCHEMATIC

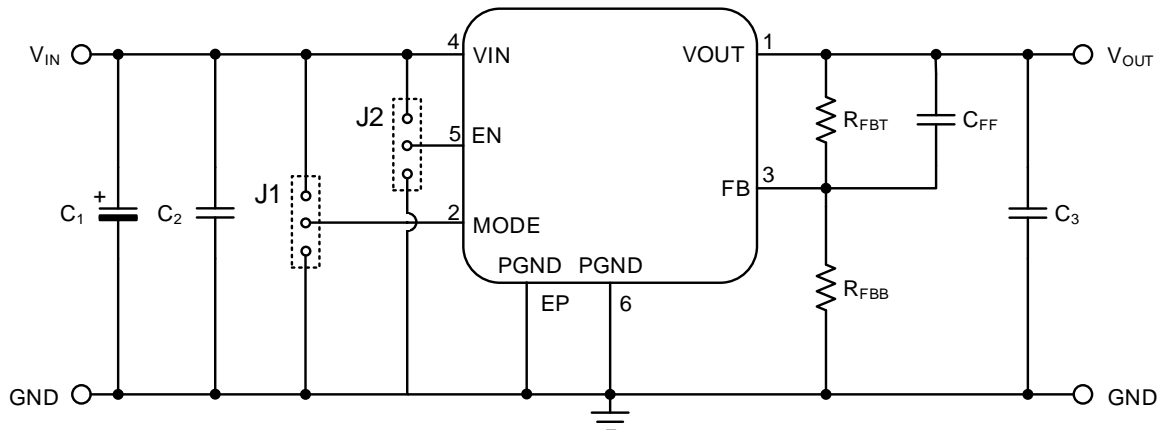

### Operational Requirements

The additional aluminum polymer capacitor C1 is only for evaluation board protection purposes. It is mounted as the termination of the supply line and provides a slight damping of possible oscillations of the series resonance circuit represented by the inductance of the supply line and the input capacitance

### Bill of Material

Designator	Description	Quantity	Order Code	Manufacturer
IC1	MagI <sup>3</sup> C MicroModule	1	171960501	Würth Elektronik
C1	Aluminum Polymer Capacitor 220µF/10V	1	875105244013	Würth Elektronik
C <sub>2</sub> ,C <sub>3</sub>	Ceramic chip capacitor 10µF/16V X5R, 0805	2	885012107014	Würth Elektronik
C <sub>FF</sub>	Ceramic chip capacitor 22pF/25V NP0/COG 0603	1		
R <sub>FBT</sub>	24.9 kΩ	1		
R <sub>FBB</sub>	open for V <sub>OUT</sub> = 0.6V			
	36.5 kΩ for V <sub>OUT</sub> = 1.0V	1		
	24.9 kΩ for V <sub>OUT</sub> = 1.2V	1		
	16.5 kΩ for V <sub>OUT</sub> = 1.5V	1		
	12.4 kΩ for V <sub>OUT</sub> = 1.8V	1		
	7.68 kΩ for V <sub>OUT</sub> = 2.5V	1		
	5.36 kΩ for V <sub>OUT</sub> = 3.3V	1		
	To be soldered for adjustable output voltage $R_{FBB} = \frac{R_{FBT}}{\frac{V_{OUT}}{V_{FB}} - 1}$			
J1	Jumper for MODE connection to either VIN (Forced PWM) or GND (PFM/PWM)	1		
J2	Jumper for EN connection to either VIN (device enabled) or GND (device disabled)	1		

# WPMDB1960501XF / 171960501

## MagI<sup>3</sup>C Power Module VDMM – Variable Step Down MicroModule



### HANDLING RECOMMENDATIONS

1. The power module is classified as MSL3 (JEDEC Moisture Sensitivity Level 3) and requires special handling due to moisture sensitivity (JEDEC J-STD033).
2. The parts are delivered in a sealed bag (Moisture Barrier Bags = MBB) and should be processed within one year.
3. When opening the moisture barrier bag check the Humidity Indicator Card (HIC) for color status. Bake parts prior to soldering in case indicator color has changed according to the notes on the card.
4. Parts must be processed after 168 hour (7 days) of floor life. Once this time has been exceeded, bake parts prior to soldering per JEDEC J-STD033 recommendation.

### SOLDER PROFILE

1. Only Pb-Free assembly is recommended according to JEDEC J-STD020.
2. Measure the peak reflow temperature of the MagI<sup>3</sup>C MicroModule in the middle of the top view.
3. Ensure that the peak reflow temperature does not exceed  $235^{\circ}\text{C} \pm 5^{\circ}\text{C}$  as per JEDEC J-STD020.
4. The reflow time period during peak temperature of  $235^{\circ}\text{C} \pm 5^{\circ}\text{C}$  must not exceed 20 seconds.
5. Reflow time above liquidus ( $217^{\circ}\text{C}$ ) must not exceed 90 seconds.
6. Maximum ramp up is rate  $3^{\circ}\text{C}$  per second.
7. Maximum ramp down rate is  $3^{\circ}\text{C}$  per second.
8. Reflow time from room ( $25^{\circ}\text{C}$ ) to peak must not exceed 8 minutes as per JEDEC J-STD020.
9. **Maximum numbers of reflow cycles is three.**
10. **For minimum risk, solder the module in the last reflow cycle of the PCB production.**
11. For soldering process please consider lead material copper (Cu) and lead finish tin (Sn).
12. For solder paste use a LFM-48W or Indium based SAC 305 alloy (Sn 96.5 / Ag 3.0 / Cu 0.5 / Indium 8.9HF / Type 3 / 89%) type 3 or higher.
13. The profile shown below is valid for convection reflow only.
14. Other soldering methods (e.g.vapor phase) are not verified and have to be validated by the customer at their own risk.

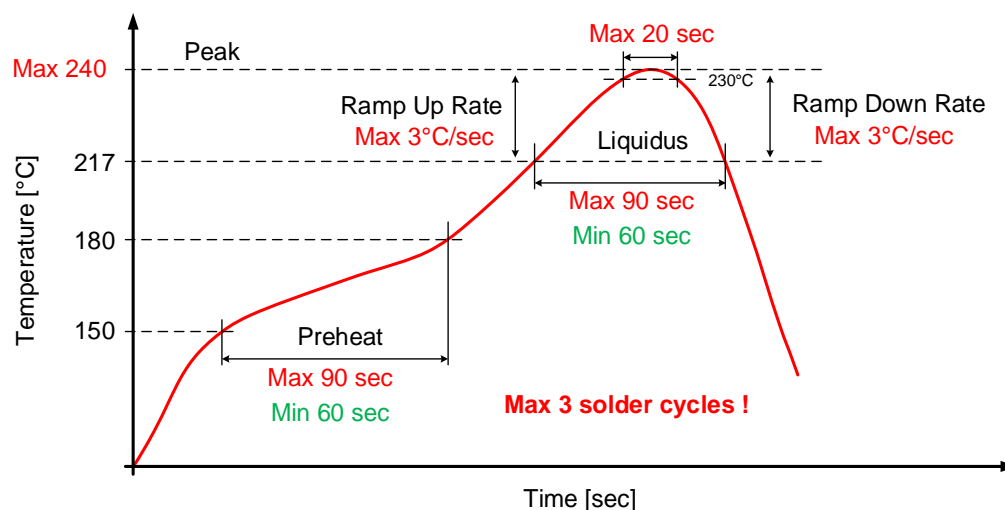

# WPMDB1960501XF / 171960501

**MagI<sup>3</sup>C** Power Module  
**VDMM** – Variable Step Down MicroModule



## PHYSICAL DIMENSIONS

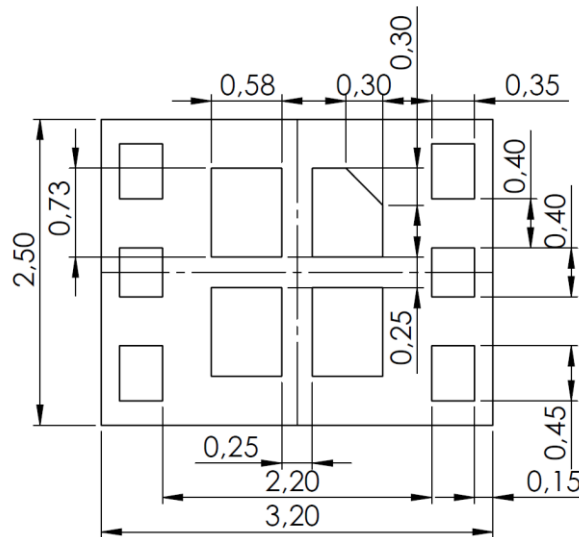

Bottom view  
 All dimensions in mm, tolerances  $\pm 0.1$ mm

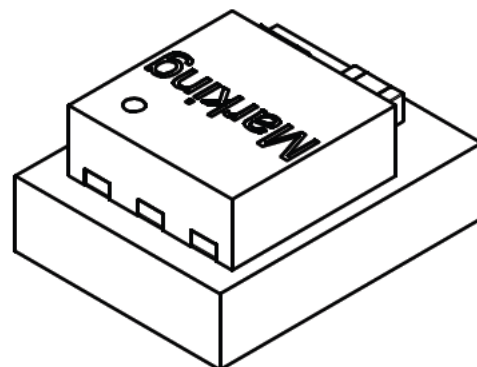
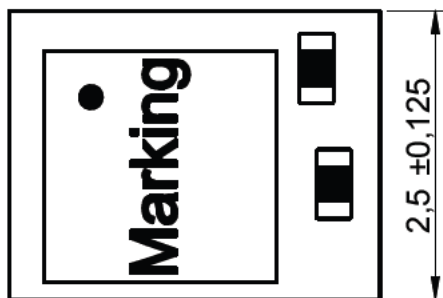
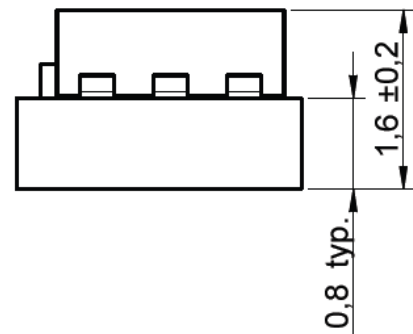
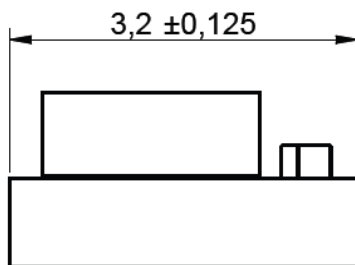

All dimensions in mm

## WPMDB1960501XF / 171960501

**MagI<sup>3</sup>C** Power Module  
VDMM – Variable Step Down MicroModule



## EXAMPLE FOOTPRINT DESIGN

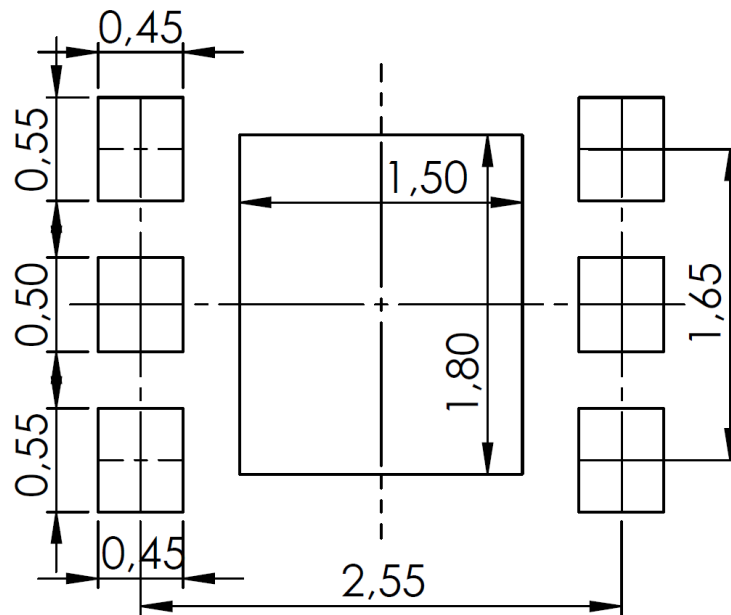

All dimensions in mm



# WPMDB1960501XF / 171960501

**MagI<sup>3</sup>C** Power Module  
**VDMM** – Variable Step Down MicroModule



## PACKAGING

Reel (mm)

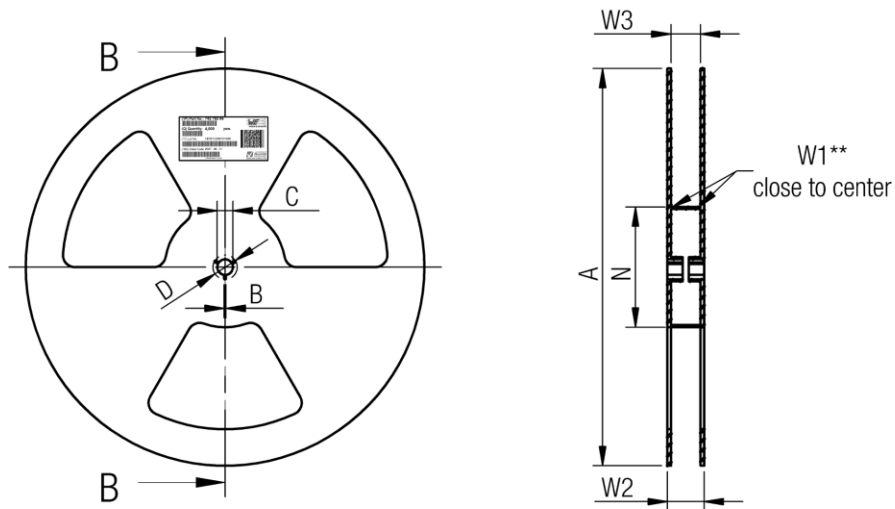

	A	B	C	D	N	W1	W2	W3	
tolerance	typ.	min.	± 0.8	min.	min.	+1.5	max.	min.	
Tape width	<b>24mm</b>	178.00	1.50	13.00	20.20	50.00	8.40	14.40	7.90

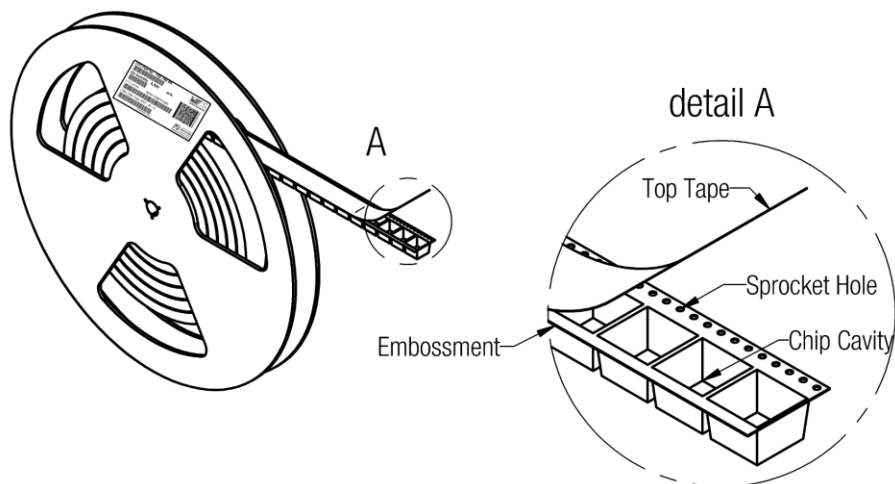

20P

# WPMDB1960501XF / 171960501

**MagI<sup>3</sup>C** Power Module  
**VDMM** – Variable Step Down MicroModule



Tape (mm)

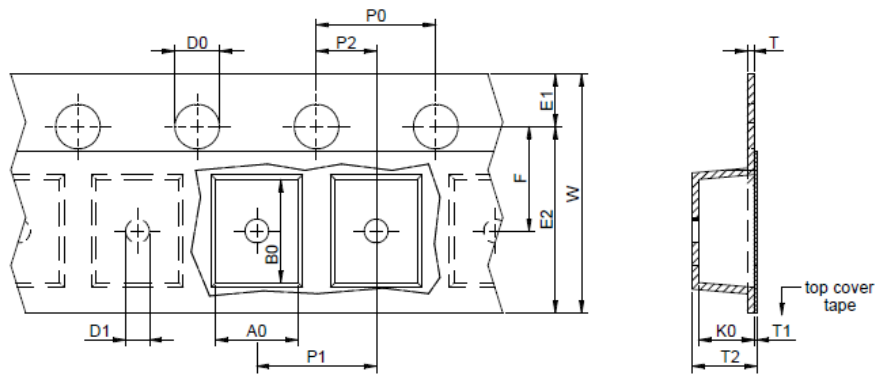

	A0	B0	W	P1	T	T1	T2	D0	E1	E2	F	P0	P2	Tape	Packaging Unit	
tolerance	±0.1	±0.1	±0.1	±0.1	±0.05	max.	typ.	±0.1	±0.1	min.	±0.1	±0.1	±0.05			
size	1210	2.75	3.45	8.00	4.00	0.22	0.10	2.20	1.50	1.75	6.25	3.50	4.00	2.00	Polystyrene	2000

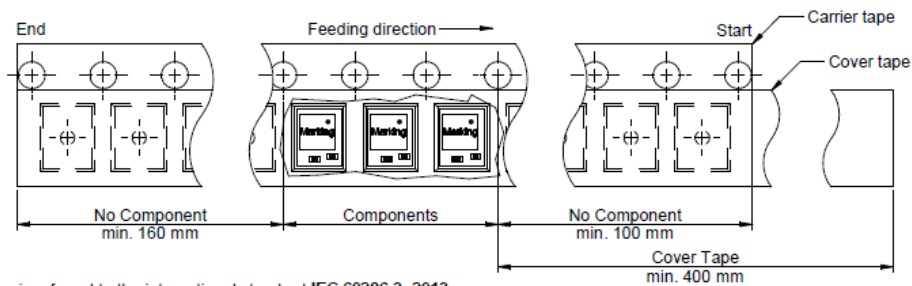

Packaging is referred to the international standard IEC 60286-3; 2013

**WPMDB1960501XF / 171960501****MagI<sup>3</sup>C** Power Module  
**VDMM** – Variable Step Down MicroModule**DOCUMENT HISTORY**

Revision	Date	Description	Comment
1.0	November 2017	Datasheet Release	

**CAUTIONS AND WARNINGS**

**The following conditions apply to all goods within the product series of MagI<sup>3</sup>C of Würth Elektronik eiSos GmbH & Co. KG:**

**General:**

All recommendations according to the general technical specifications of the data-sheet have to be complied with.

The usage and operation of the product within ambient conditions which probably alloy or harm the component surface has to be avoided.

The responsibility for the applicability of customer specific products and use in a particular customer design is always within the authority of the customer. All technical specifications for standard products do also apply for customer specific products.

Residual washing varnish agent that is used during the production to clean the application might change the characteristics of the body, pins or termination. The washing varnish agent could have a negative effect on the long term function of the product. Direct mechanical impact to the product shall be prevented as the material of the body, pins or termination could flake or in the worst case it could break. As these devices are sensitive to electrostatic discharge customer shall follow proper IC Handling Procedures.

Customer acknowledges and agrees that it is solely responsible for compliance with all legal, regulatory and safety-related requirements concerning its products, and any use of Würth Elektronik eiSos GmbH & Co. KG components in its applications, notwithstanding any applications-related information or support that may be provided by Würth Elektronik eiSos GmbH & Co. KG. Customer represents and agrees that it has all the necessary expertise to create and implement safeguards which anticipate dangerous consequences of failures, monitor failures and their consequences lessen the likelihood of failures that might cause harm and take appropriate remedial actions. Customer will fully indemnify Würth Elektronik eiSos and its representatives against any damages arising out of the use of any Würth Elektronik eiSos GmbH & Co. KG components in safety-critical applications.

**Product specific:**

Follow all instructions mentioned in the datasheet, especially:

- The solder profile has to comply with the technical reflow or wave soldering specification, otherwise this will void the warranty.
- All products are supposed to be used before the end of the period of 12 months based on the product date-code.
- Violation of the technical product specifications such as exceeding the absolute maximum ratings will void the warranty.
- It is also recommended to return the body to the original moisture proof bag and reseal the moisture proof bag again.
- ESD prevention methods need to be followed for manual handling and processing by machinery.

**WPMDB1960501XF / 171960501****Magl<sup>3</sup>C Power Module**  
**VDMM – Variable Step Down MicroModule****IMPORTANT NOTES**

The following conditions apply to all goods within the product range of Würth Elektronik eiSos GmbH & Co. KG:

**1. General Customer Responsibility**

Some goods within the product range of Würth Elektronik eiSos GmbH & Co. KG contain statements regarding general suitability for certain application areas. These statements about suitability are based on our knowledge and experience of typical requirements concerning the areas, serve as general guidance and cannot be estimated as binding statements about the suitability for a customer application. The responsibility for the applicability and use in a particular customer design is always solely within the authority of the customer. Due to this fact it is up to the customer to evaluate, where appropriate to investigate and decide whether the device with the specific product characteristics described in the product specification is valid and suitable for the respective customer application or not. Accordingly, the customer is cautioned to verify that the datasheet is current before placing orders.

**2. Customer Responsibility related to Specific, in particular Safety-Relevant Applications**

It has to be clearly pointed out that the possibility of a malfunction of electronic components or failure before the end of the usual lifetime cannot be completely eliminated in the current state of the art, even if the products are operated within the range of the specifications. In certain customer applications requiring a very high level of safety and especially in customer applications in which the malfunction or failure of an electronic component could endanger human life or health it must be ensured by most advanced technological aid of suitable design of the customer application that no injury or damage is caused to third parties in the event of malfunction or failure of an electronic component.

**3. Best Care and Attention**

Any product-specific notes, warnings and cautions must be strictly observed.

**4. Customer Support for Product Specifications**

Some products within the product range may contain substances which are subject to restrictions in certain jurisdictions in order to serve specific technical requirements. Necessary information is available on request. In this case the field sales engineer or the internal sales person in charge should be contacted who will be happy to support in this matter.

**5. Product R&D**

Due to constant product improvement product specifications may change from time to time. As a standard reporting procedure of the Product Change Notification (PCN) according to the JEDEC-Standard we inform about minor and major changes. In case of further queries regarding the PCN, the field sales engineer or the internal sales person in charge should be contacted. The basic responsibility of the customer as per Section 1 and 2 remains unaffected.

**6. Product Life Cycle**

Due to technical progress and economical evaluation we also reserve the right to discontinue production and delivery of products. As a standard reporting procedure of the Product Termination Notification (PTN) according to the JEDEC-Standard we will inform at an early stage about inevitable product discontinuance. According to this we cannot guarantee that all products within our product range will always be available. Therefore it needs to be verified with the field sales engineer or the internal sales person in charge about the current product availability expectancy before or when the product for application design-in disposal is considered. The approach named above does not apply in the case of individual agreements deviating from the foregoing for customer-specific products.

**7. Property Rights**

All the rights for contractual products produced by Würth Elektronik eiSos GmbH & Co. KG on the basis of ideas, development contracts as well as models or templates that are subject to copyright, patent or commercial protection supplied to the customer will remain with Würth Elektronik eiSos GmbH & Co. KG. Würth Elektronik eiSos GmbH & Co. KG does not warrant or represent that any license, either expressed or implied, is granted under any patent right, copyright, mask work right, or other intellectual property right relating to any combination, application, or process in which Würth Elektronik eiSos GmbH & Co. KG components or services are used.

**8. General Terms and Conditions**

Unless otherwise agreed in individual contracts, all orders are subject to the current version of the "General Terms and Conditions of Würth Elektronik eiSos Group", last version available at [www.we-online.com](http://www.we-online.com).