

PART NAME: KNOB SCALE: 1:1 DATE: 5/10/05 DR. BY JAM

THIS DRAWING IS THE PROPERTY OF DAVIES MOLDING COMPANY, IS SUBMITTED SOLELY AS A DESIGN OR ENGINEERING PROJECT. WE ACCEPT NO RESPONSIBILITY WHATSOEVER FOR THE PRACTICAL APPLICATION OF THE PIECES MADE TO THIS DESIGN.

DAVIES MOLDING COMPANY
CAROL STREAM, ILLINOIS 60188

P/N 1520AT
BASE PART 1520-03
SPRING 11125A

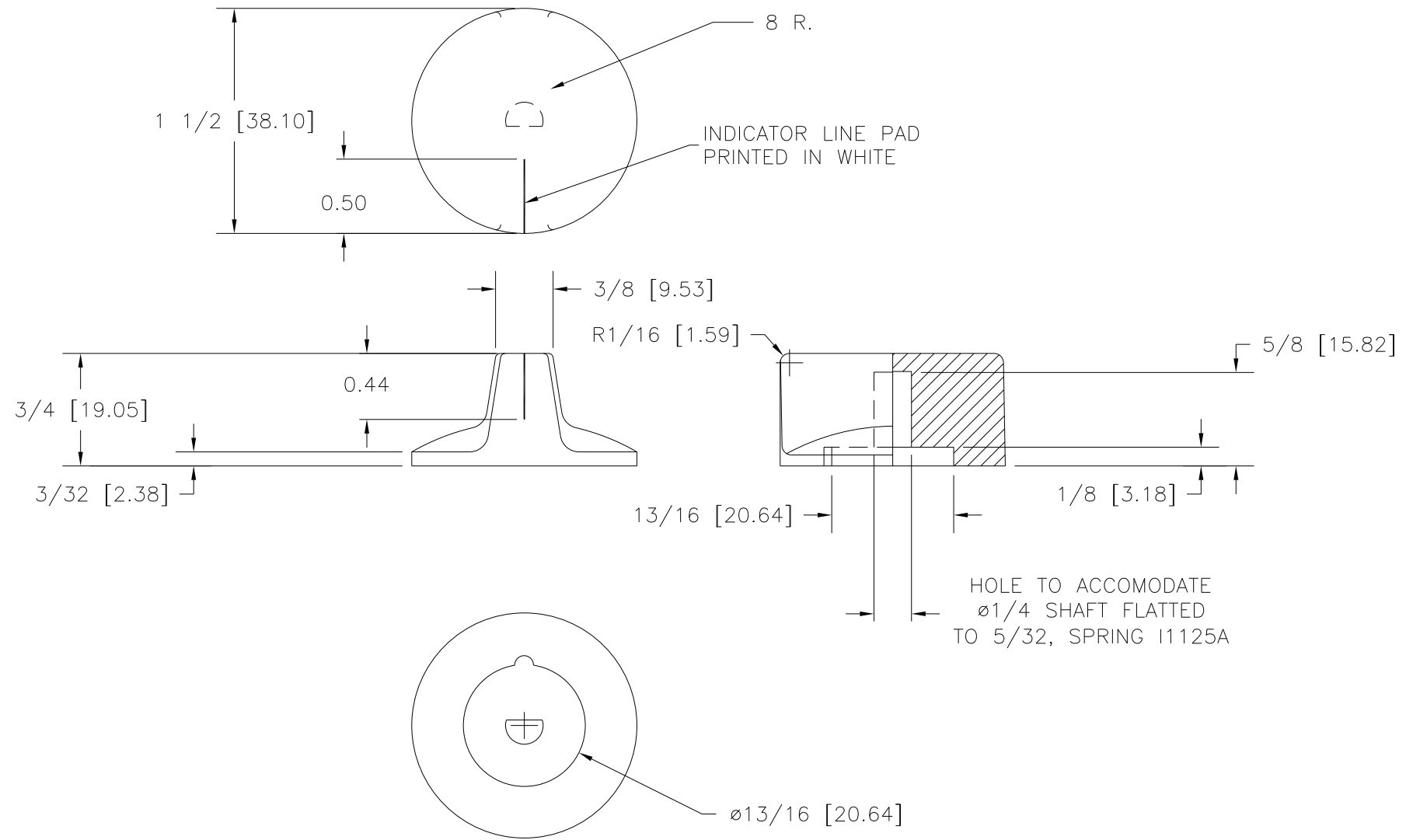

MATERIAL: G.P. PHENOLIC (B11)
COLOR: BLACK

TOLERANCES: UNLESS OTHERWISE SPECIFIED	DO NOT SCALE DRAWING			
DECIMALS: X.XXX ± .005 X.XX ± .015	MM: X.XX ± 0.15MM X.X ± 0.4MM	-	WAS SK1520-15	JAM 5/10/05
FRACTIONS ± 1/64	ANG. ± 1°	CHANGES		