

THIS DRAWING IS UNPUBLISHED. RELEASED FOR PUBLICATION
 © COPYRIGHT - By - ALL RIGHTS RESERVED.

LOC	DIST	REVISIONS			
P	LTR	DESCRIPTION	DATE	DWN	APVD
GP	00	A	INITIAL RELEASE	01/AUG/11	ECC PB

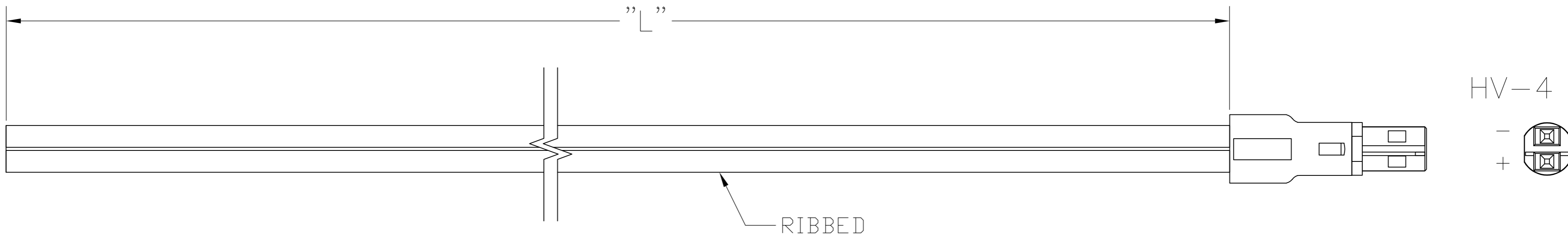

RIBBED

WIRING SCHEDULE		
	SIDE	PLUG
+	RIBBED	1
-	SMOOTH	2

3

1. PACKAGING ACC. TO TE SPEC.107-18032
BUNDLE EVERY 25 ASSEMBLIES WITH A RUBBER BAND
2. ELECTRICAL TEST CONTAINING "SHORT CIRCUIT TEST, CONTINUITY AND ACCURATE CAVITY ASSIGNMENT TEST" ACC. TO TE-SPEC.108-18857, SUBSECTION 3.1.1

3 WIRING SCHEDULE AS SHOWN

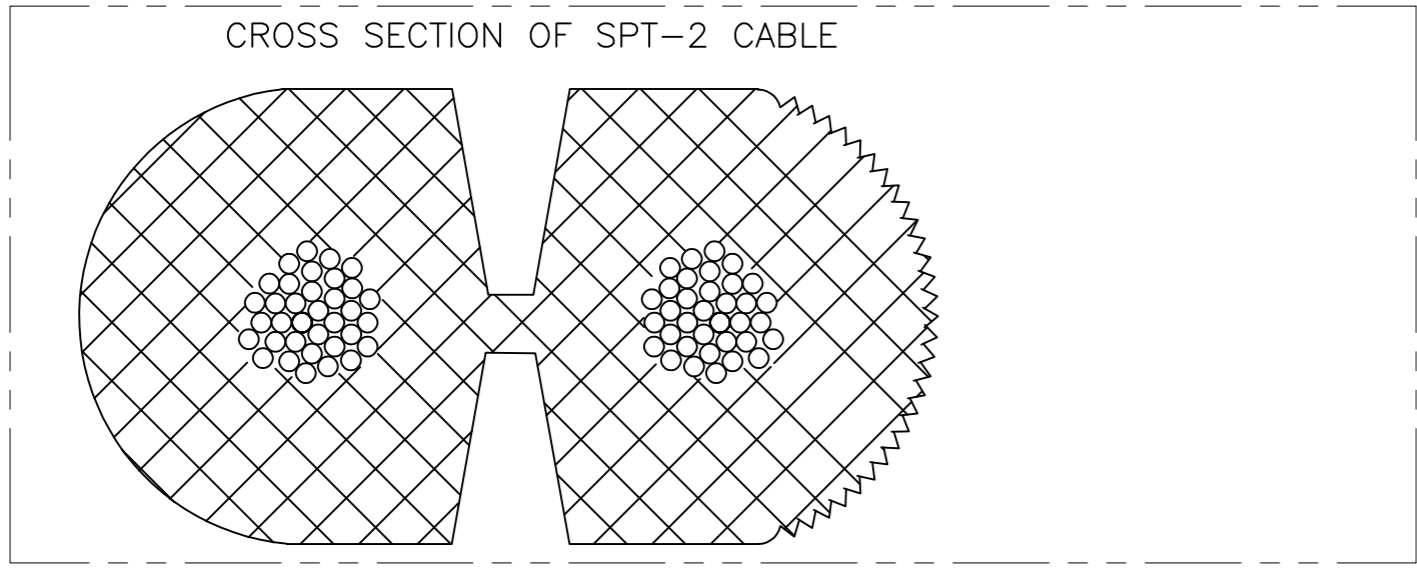

CROSS SECTION OF SPT-2 CABLE

16.0 FT	±3.84	2181194-8
14.0 FT	±3.36	2181194-7
12.0 FT	±2.88	2181194-6
10.0 FT	±2.4	2181194-5
8.0 FT	±1.92	2181194-4
6.0 FT	±1.44	2181194-3
4.0 FT	±.96	2181194-2
2.0 FT	±.48	2181194-1
"L"	TOLERANCES [INCHES]	TE P/N

THIS DRAWING IS A CONTROLLED DOCUMENT.		DWN E.C. CLAYBAUGH 17/JUN/11		
DIMENSIONS: INCHES		CHK P. BECKER 13/JUL/11		
TOLERANCES UNLESS OTHERWISE SPECIFIED:		APVD P. BECKER 01/AUG/11	NAME CABLE ASSEMBLY, NECTOR, HV-4, PLUG - PIGTAIL	
0 PLC ± -		PRODUCT SPEC	-	
1 PLC ± -		APPLICATION SPEC	-	
2 PLC ± -		WEIGHT	-	
3 PLC ± -		SIZE	A2	
4 PLC ± -		CAGE CODE	00779	
ANGLES ± -		DRAWING NO	C-2181194	
FINISH		RESTRICTED TO	-	
MATERIAL		CUSTOMER DRAWING	SCALE N.T.S. SHEET 1 of 1 REV A	

2181194