

OD8015 Series

DC



80x80x15mm  
(3.15"x 3.15"x 0.59")



**OPERATING TEMPERATURE**

Ball Bearing  
-20C ~ +70C  
Sleeve Bearing  
-10C ~ +50C

**FRAME & IMPELLER**

PBT, UL94V-0 Thermoplastic

**POWER CONNECTION**

Two lead wires 300mm (12")

**AVAILABLE OPTIONS**

Tachometer  
Locked rotor Alarm

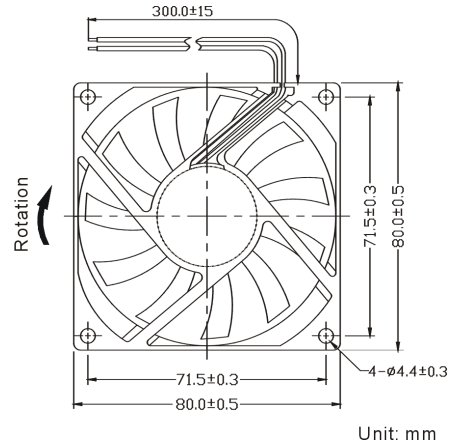
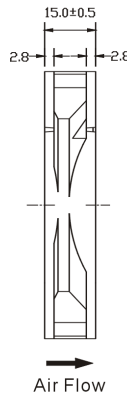

FINGER GUARD: G80-18  
PLASTIC GUARD: G80P  
WIRE MESH GUARD: WMG80M  
FILTER KIT: GRM80-30,  
GRM80-45

MODEL NUMBER	SPEED (RPM)	AIRFLOW (CFM)	NOISE (DB)	VOLTS DC	VOLTAGE RANGE	AMPS	MAX. STATIC PRESSURE (H <sub>2</sub> O)
OD8015-05H*	3200	30	33	05	4~7	.43	.11
OD8015-05M*	2440	21	26	05	4~7	.24	.08
OD8015-12H*	3200	31	33	12	8~16	.19	.11
OD8015-12M*	2440	21	26	12	8~16	.15	.08

\* Indicate "B" to specify Ball bearing or "S" to specify Sleeve bearing

**MOTOR**

Brushless DC, Impedance and polarity protected, auto restart

**INSULATION RESISTANCE**

Min. 10M at 500VDC

**DIELECTRIC STRENGTH**

1 minute at 500VAC / 1 second, max leakage 500 microamp

**LIFE EXPECTANCY (L10)**

Ball Bearing 60,000 hrs  
Sleeve Bearing 30,000 hrs

