

THIS DRAWING IS UNPUBLISHED. RELEASED FOR PUBLICATION
 © COPYRIGHT copyright.d8Te- ALL RIGHTS RESERVED.

REVISIONS					
P	LTR	DESCRIPTION	DATE	DWN	APVD
A		NEW DRAWING	10SEP2016	RS	ML
A1		REVISED PER ECR-16-016988	03JAN2017	RK	PO

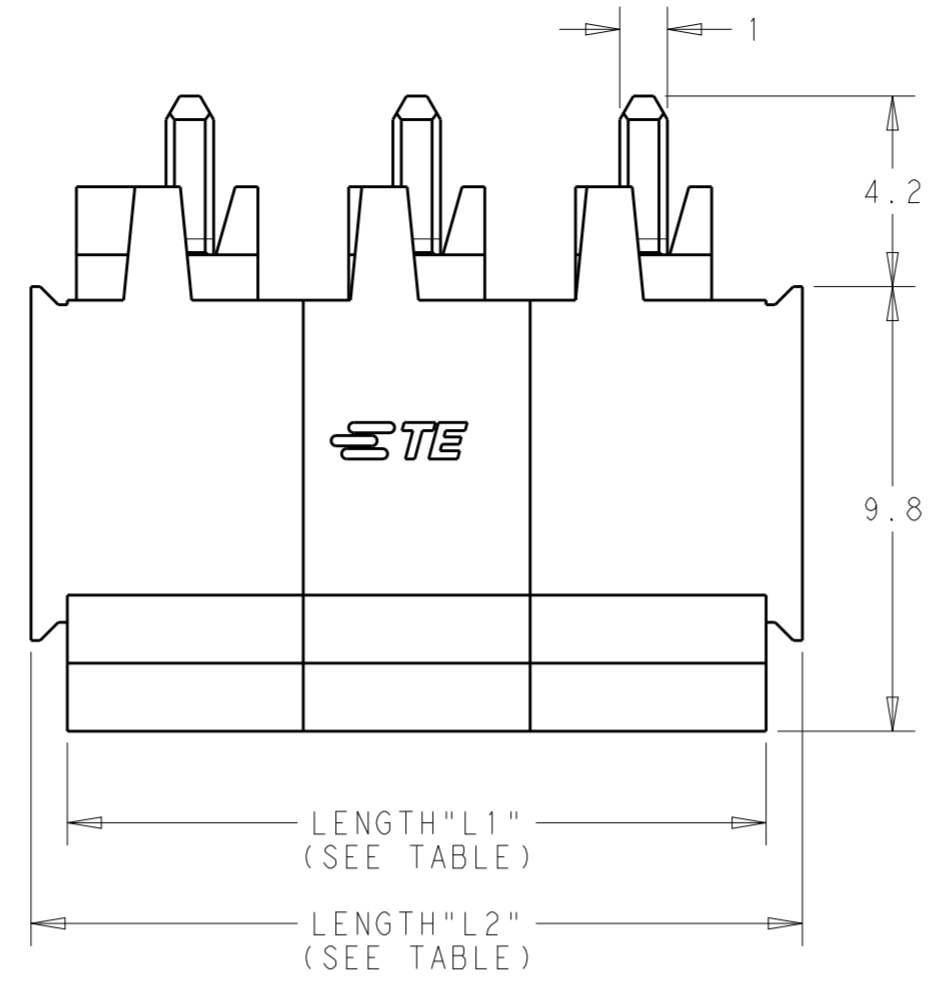

- HOUSING MATERIAL: THERMOPLASTIC, FLAME-RETARDANT PER UL 94 V-0
COLOR = BLACK
- CONTACT MATERIAL: COPPER ALLOY WITH TIN PLATE
- PRODUCT CERTIFICATIONS:
UL, CSA: 300V (SEE TABLE FOR RATED CURRENT)
- HAZARDOUS SUBSTANCE COMPLIANCE: RoHS, REACH
- PACKAGING: TAPE AND REEL
REEL DIAMETER = 380mm
TAPE WIDTH = SEE TABLE
- MATES WITH 2213934 SERIES, 2213935 SERIES, AND 2305909 SERIES

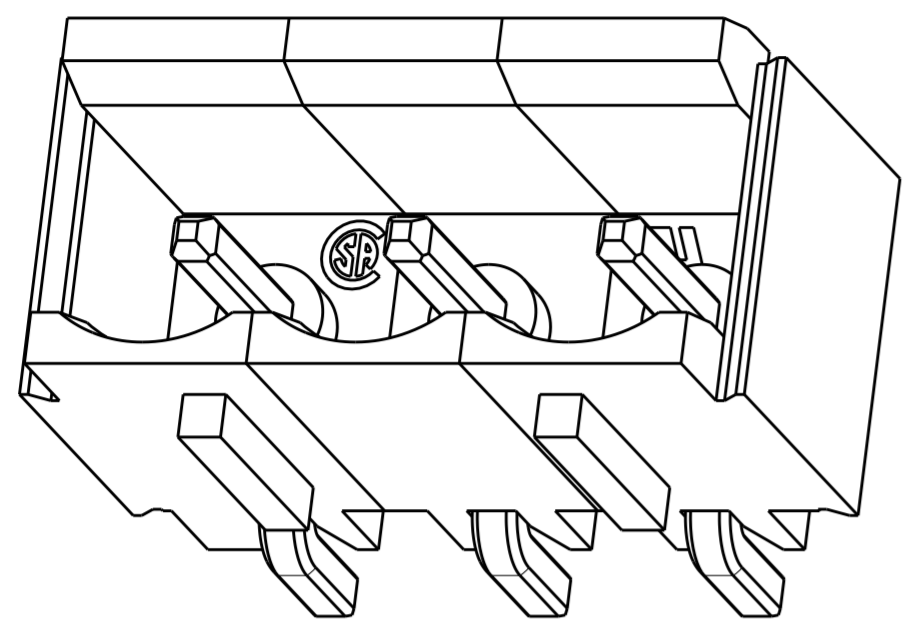
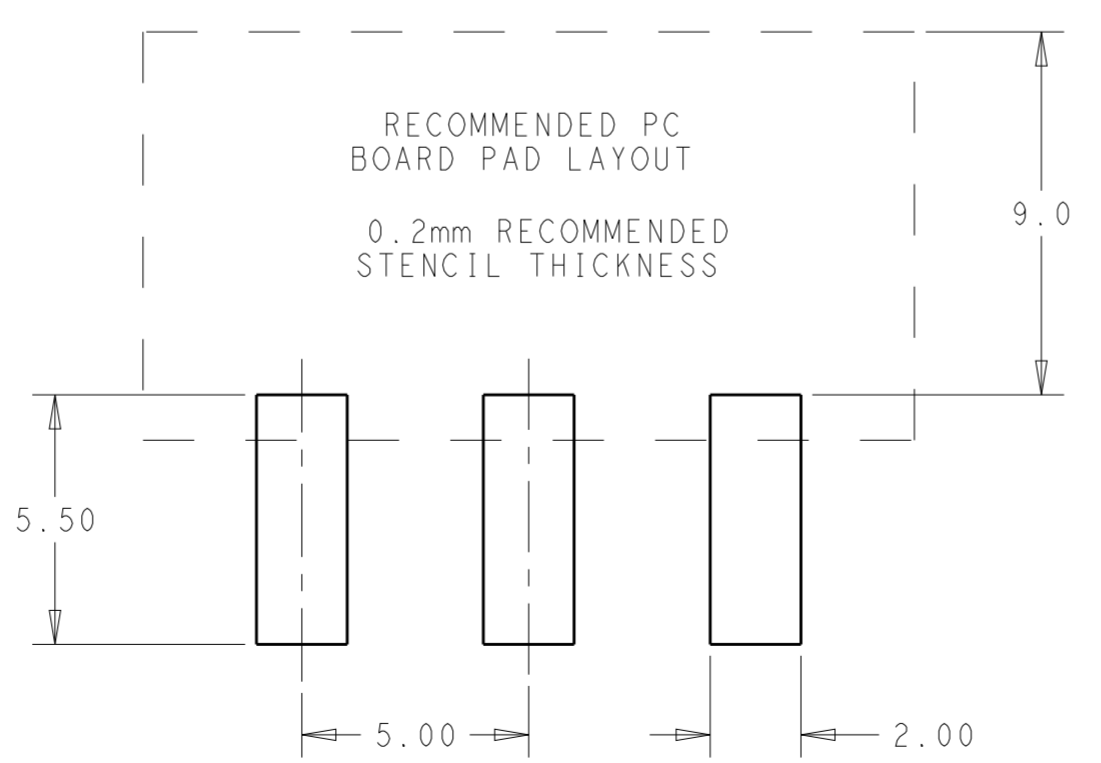
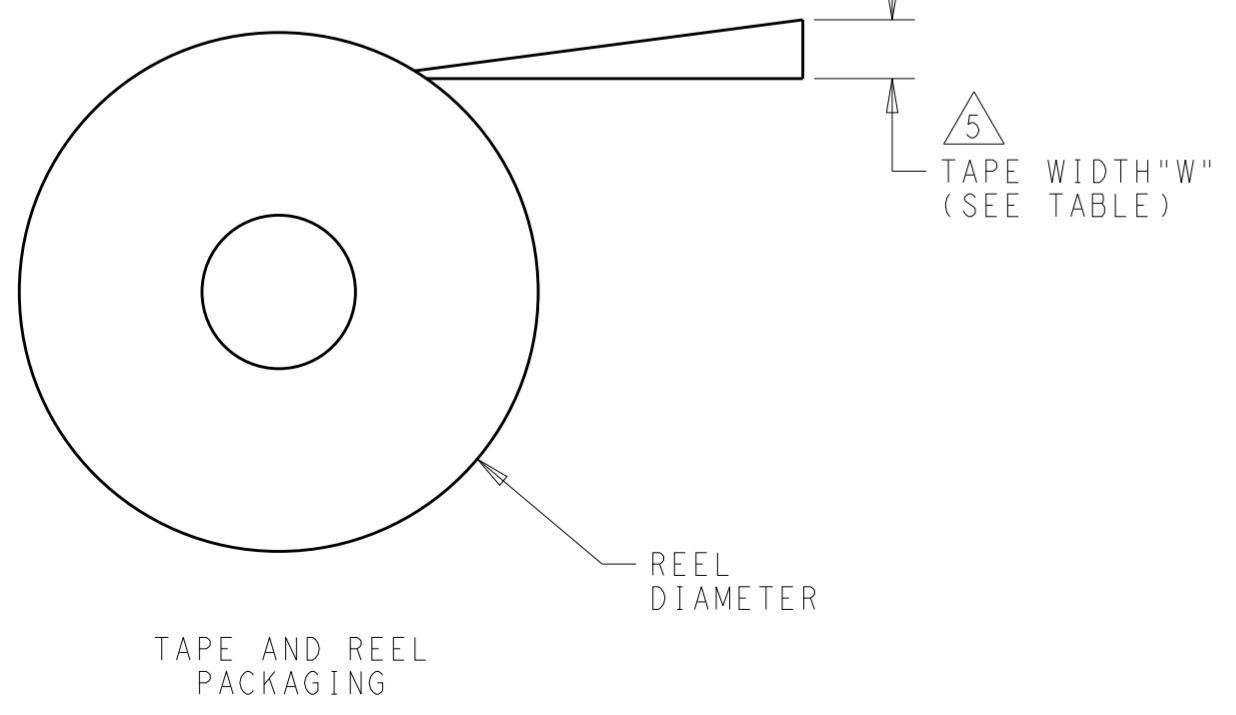
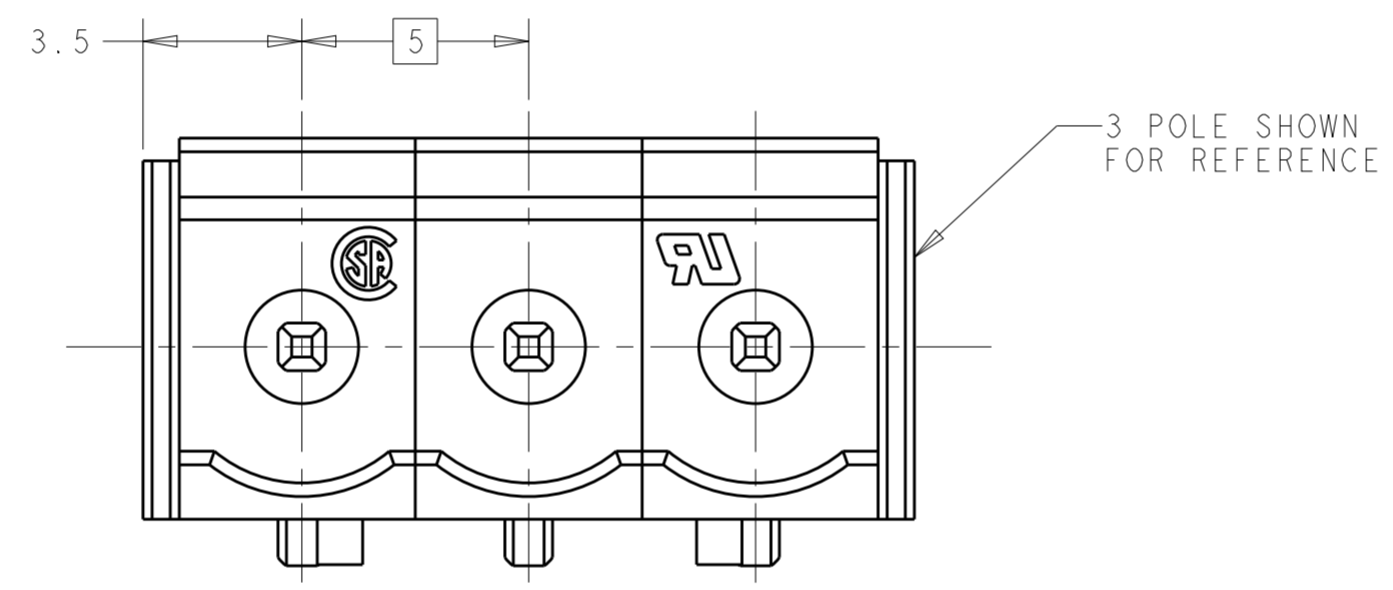
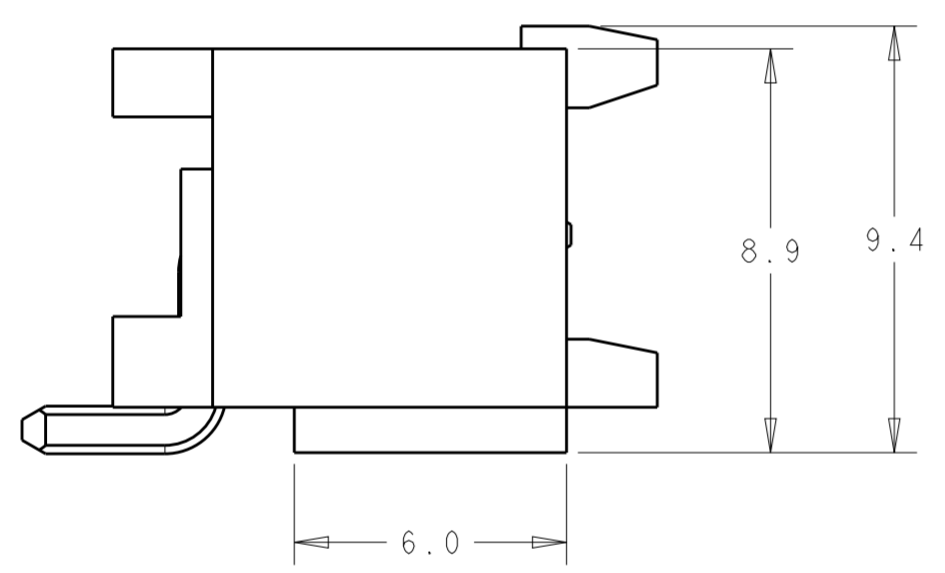

RATED CURRENT	UL GROUP	CSA GROUPS	TAPE WIDTH "W" (mm)	LENGTH "L2" (mm)	LENGTH "L1" (mm)	NO. OF POLES	TE PART NO.
10A	UL GROUP D	CSA GROUPS D, E	88	62.0	60.4	12	1-2305908-2
				57.0	55.4	11	1-2305908-1
15A	UL GROUP B	CSA GROUP B	72	52.0	50.4	10	1-2305908-0
				47.0	45.4	9	2305908-9
			56	42.0	40.4	8	2305908-8
				37.0	35.4	7	2305908-7
			44	32.0	30.4	6	2305908-6
				27.0	25.4	5	2305908-5
24				22.0	20.4	4	2305908-4
				17.0	15.4	3	2305908-3
				12.0	10.4	2	2305908-2

THIS DRAWING IS A CONTROLLED DOCUMENT.

DIMENSIONS: mm	TOLERANCES UNLESS OTHERWISE SPECIFIED:	DWN: RAVLS 10SEP2016	 TE Connectivity
0 PLC ±	±0.2	CHK: M.LUKSIC 10SEP2016	
1 PLC ±	±0.13	APVD: M.LUKSIC 10SEP2016	
2 PLC ±	±	PRODUCT SPEC	NAME: TERMINAL BLOCK HEADER, RIGHT ANGLE, SMT, 5.0MM PITCH
3 PLC ±	±	APPLICATION SPEC	SIZE: A2
4 PLC ±	±	WEIGHT	CAGE CODE: -
ANGLES	±	CUSTOMER DRAWING	DRAWING NO: C-2305908
FINISH	-	SCALE: 5:1	SHEET 1 OF 2
MATERIAL: SEE NOTES	-	RESTRICTED TO: -	REV: A1

THIS DRAWING IS UNPUBLISHED. RELEASED FOR PUBLICATION
 © COPYRIGHT copyright_dBTe- ALL RIGHTS RESERVED.

REVISIONS				
P	LTR	DESCRIPTION	DATE	APVD
-		SEE SHEET 1	-	-

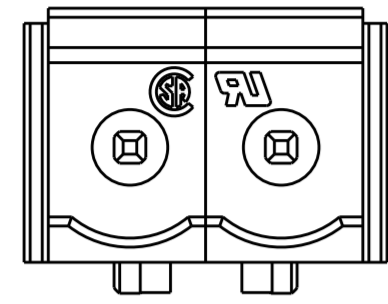

2 POLES: 2305908-2

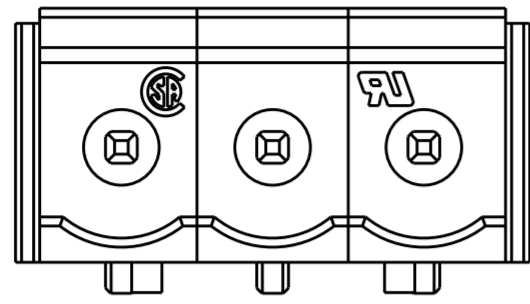

3 POLES: 2305908-3

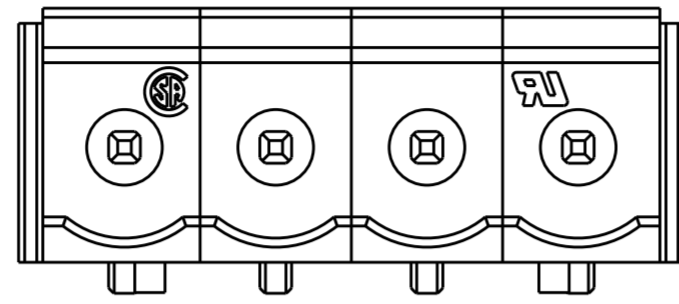

4 POLES: 2305908-4

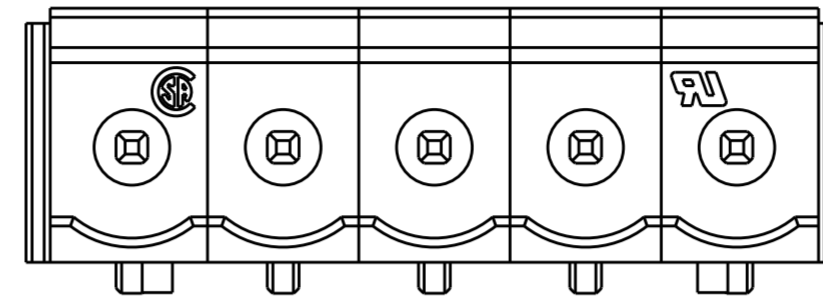

5 POLES: 2305908-5

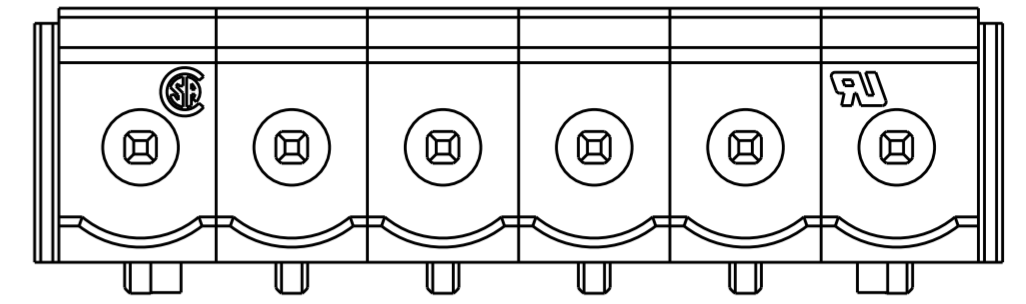

6 POLES: 2305908-6

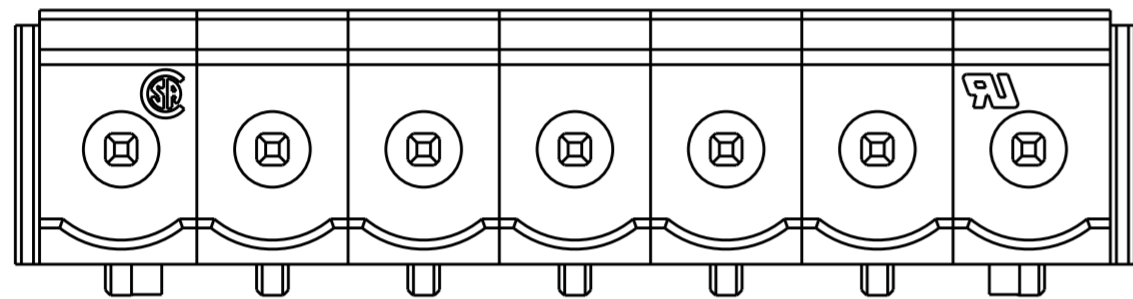

7 POLES: 2305908-7

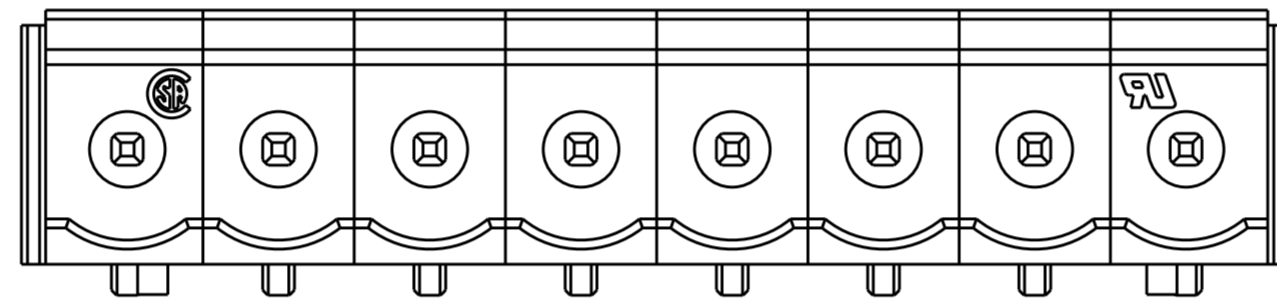

8 POLES: 2305908-8

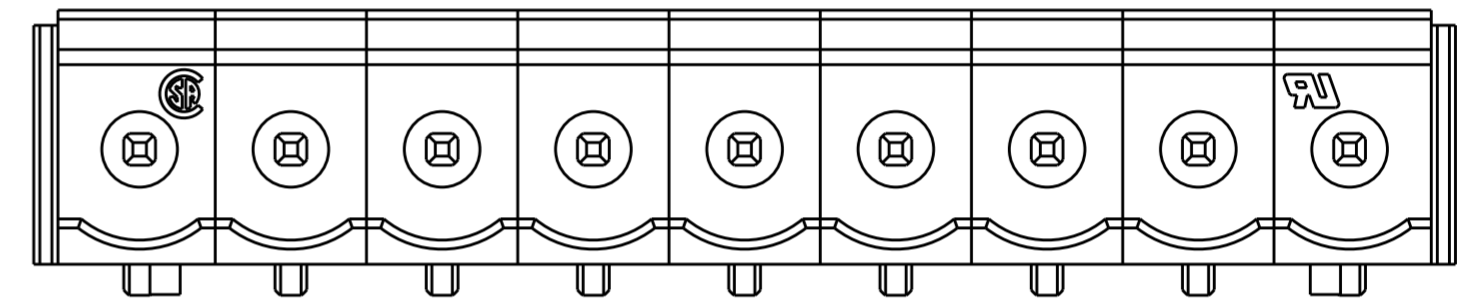

9 POLES: 2305908-9

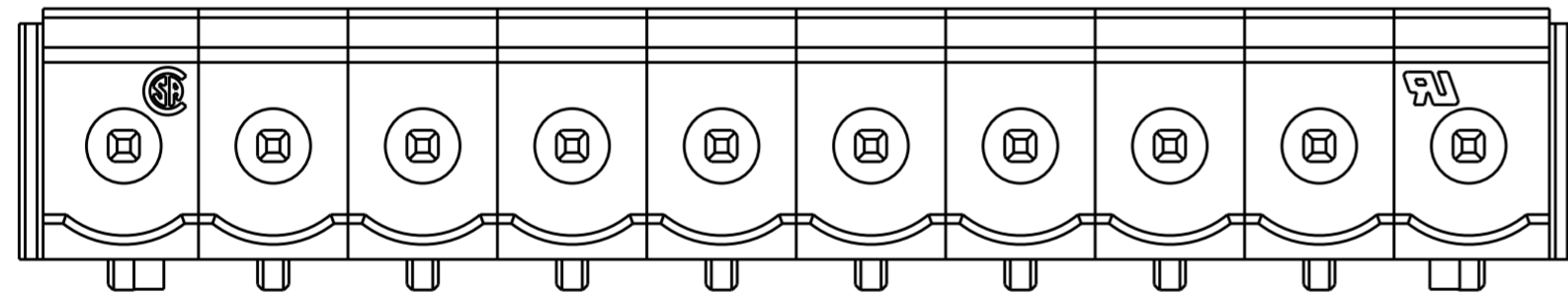

10 POLES: 1-2305908-0

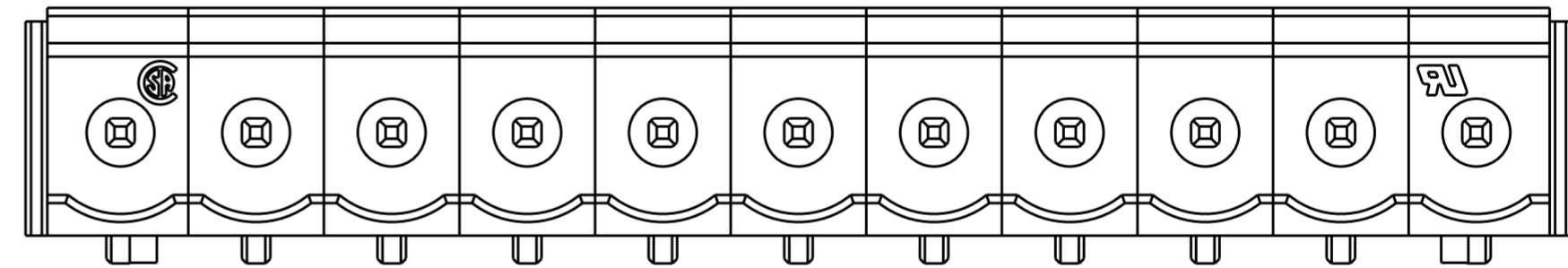

11 POLES: 1-2305908-1

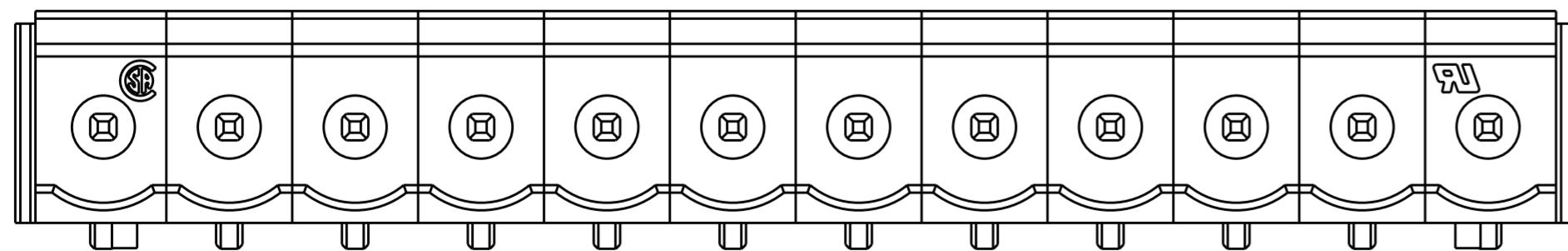

12 POLES: 1-2305908-2

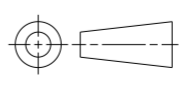
THIS DRAWING IS A CONTROLLED DOCUMENT.		DWN RAVLS 10SEP2016	 TE Connectivity	
DIMENSIONS: mm		CHK M.LUKSIC 10SEP2016		
TOLERANCES UNLESS OTHERWISE SPECIFIED:		APVD M.LUKSIC 10SEP2016	NAME TERMINAL BLOCK HEADER, RIGHT ANGLE, SMT, 5.0MM PITCH	
		PRODUCT SPEC -	SIZE A2	
MATERIAL -		APPLICATION SPEC -	CAGE CODE -	DRAWING NO. G-2305908
WEIGHT -		CUSTOMER DRAWING	RESTRICTED TO -	SCALE 5:1
			SHEET 2 OF 2	REV A1