

Low Voltage Ideal Diode Controller  
 with Monitoring

## DESCRIPTION

Demonstration circuit 1329 showcases the LTC4352, a Low Voltage Ideal Diode Controller w/ Monitoring, in a DFN-12 package. The LTC4352 creates a near-ideal diode using external N-channel MOSFET thereby replacing high power Schottky diode and associated heat sink. Ideal diodes enable low loss power ORing and supply holdup applications.

**Design files for this circuit board are available. Call the LTC factory.**

L, LTC, LTM, LT, Burst Mode, OPTI-LOOP, Over-The-Top and PolyPhase are registered trademarks of Linear Technology Corporation. Adaptive Power, C-Load, DirectSense, Easy Drive, FilterCAD, Hot Swap, LinearView,  $\mu$ Module, Micropower SwitcherCAD, Multimode Dimming, No Latency  $\Delta\Sigma$ , No Latency Delta-Sigma, No  $R_{SENSE}$ , Operational Filter, PanelProtect, PowerPath, PowerSOT, SmartStart, SoftSpan, Stage Shedding, SwitcherCAD, ThinSOT, UltraFast and VLDO are trademarks of Linear Technology Corporation. Other product names may be trademarks of the companies that manufacture the products.

 PERFORMANCE SUMMARY **Specifications are at TA = 25°C**

SYMBOL	PARAMETER	CONDITIONS	MIN	TYP	MAX	UNITS
$V_{IN}$	Input Operating Range		2.9		18	V
		With External 2.9V to 4.7V $V_{CC}$ Supply	0		$V_{CC}$	
		With External 4.7V to 6V $V_{CC}$ Supply	0		18	
$I_{OUT}$	Output Load Current		0		10	A
$V_{CC(EXT)}$	$V_{CC}$ External Supply Range	$V_{IN} < V_{CC}$	2.9		6	V
$V_{CC(INT)}$	$V_{CC}$ Internal Regulator Voltage		3.4	4.1	4.6	V
$V_{FWD(REG)}$	Forward Regulation Voltage ( $V_{IN} - V_{OUT}$ )		10	25	40	mV

## OPERATING PRINCIPLES

The LTC4352 regulates the forward voltage drop across the external MOSFET to ensure smooth current transfer in diode-OR applications. A fast turn-on reduces the load voltage droop during supply switch-over. If the input supply fails or is shorted, a fast turn-off minimizes reverse current. The controller operates with rail voltages from 2.9V to 18V. Operation with rail voltages below 2.9V requires additional supply on  $V_{CC}$  from 2.9V to 6.0V.

Undervoltage and overvoltage protection (not used in the demo board circuit) allows the controller to operate in a restricted input voltage range.

The controller features an open MOSFET detect circuit that flags excessive voltage drop across the pass transistor in the on state.

The STATUS pin signal (green LED) indicates the MOSFET on state, and the FAULT pin signal (red LED) indicates an undervoltage, overvoltage or open MOSFET fault.

## QUICK START PROCEDURE

Demonstration circuit 1329 is easy to set up to evaluate the performance of the LTC4352. Refer to **Error! Reference source not found.** for proper measurement equipment setup. The DC1329 includes two identical but separate circuits. In the sample test procedure below, each circuit tested as a single ideal diode (described for top-half circuit #1) and after that both circuit are tested for OR-ing operation with a common load.

### Ideal Diode Test.

1. Place jumper JP1 (REV1) in the LOW position

**JP1 (REV1) LOW**

2. Adjust lab power supply output voltage to 2.9V. Place voltmeters to measure DC1329 input voltage (Vin1), voltage between VIN1 and VOUT1 turrets (Vin1-VOUT1), and VCC1 voltage. Turn switch SW1 on to apply 2.9V to the board. The STATUS green LED should light.
3. Increase the input voltage from 2.9V up to 17V and observe that voltage between VIN1 and VOUT1 is the Forward Regulation Voltage of  $25\text{mV} \pm 15\text{mV}$ , the voltage at the VCC1 turret follows closely below the input voltage from 2.9V up to 4.1V, and regulates to 4.1V with higher input voltages. The STATUS LED should stay green.
4. Adjust the board input voltage to +5.0V. Connect one terminal of a test lead to the GND turret and other to the UV pin (pin 3). The FAULT red LED should light and STATUS green LED goes off.
5. Connect one terminal of the test lead to the VIN1 turret and other to the OV pin (pin4). The FAULT red LED should light and STATUS green LED goes out.
6. Note: The UV and OV pin thresholds are 500mV +/-10mV. Appropriate dividers on

these pins set the overvoltage and undervoltage levels.

7. Place jumper JP1 in the HIGH position. Apply 5V VIN1. Measure voltage between VIN1 and VOUT1 turrets with no load. The voltage should be lower than 1mV. Replace JP1 to LOW position.
8. With VIN1=5V apply 10A electronic load between VOUT1 and GND. Measure VIN1-VOUT1 voltage, it should be between 40mV and 60mV.
9. With VIN1=5V connect a 9V alkaline battery's negative terminal to GND and the positive terminal to VOUT1. The STATUS green LED will turn off, as the circuit is preventing reverse current from flowing.

### Ideal Diode-ORing Test.

10. Adjust both supplies' output voltage to 5V. Turn both switches SW1 and SW2 on. In the case when only one ideal-diode is on, slightly increase the output voltage of the supply operating in the off channel to have both channels on. If both channels are on, slightly change the output voltage of one supply to check that one ideal-diode channel will be off when difference between input voltages exceeds difference between forward regulation voltages ( $25\text{mV} \pm 15\text{mV}$ ).
11. Adjust both supplies output voltage to 5V. Turn both switches SW1 and SW2 on. Make both channels on as described in paragraph 11. Apply a common load of 10A. Slightly change the output voltage of one supply to check that one ideal-diode channel will be off when difference between input voltages exceeds sum of difference between forward regulation voltages and difference between voltage drops in the MOSFET and traces.

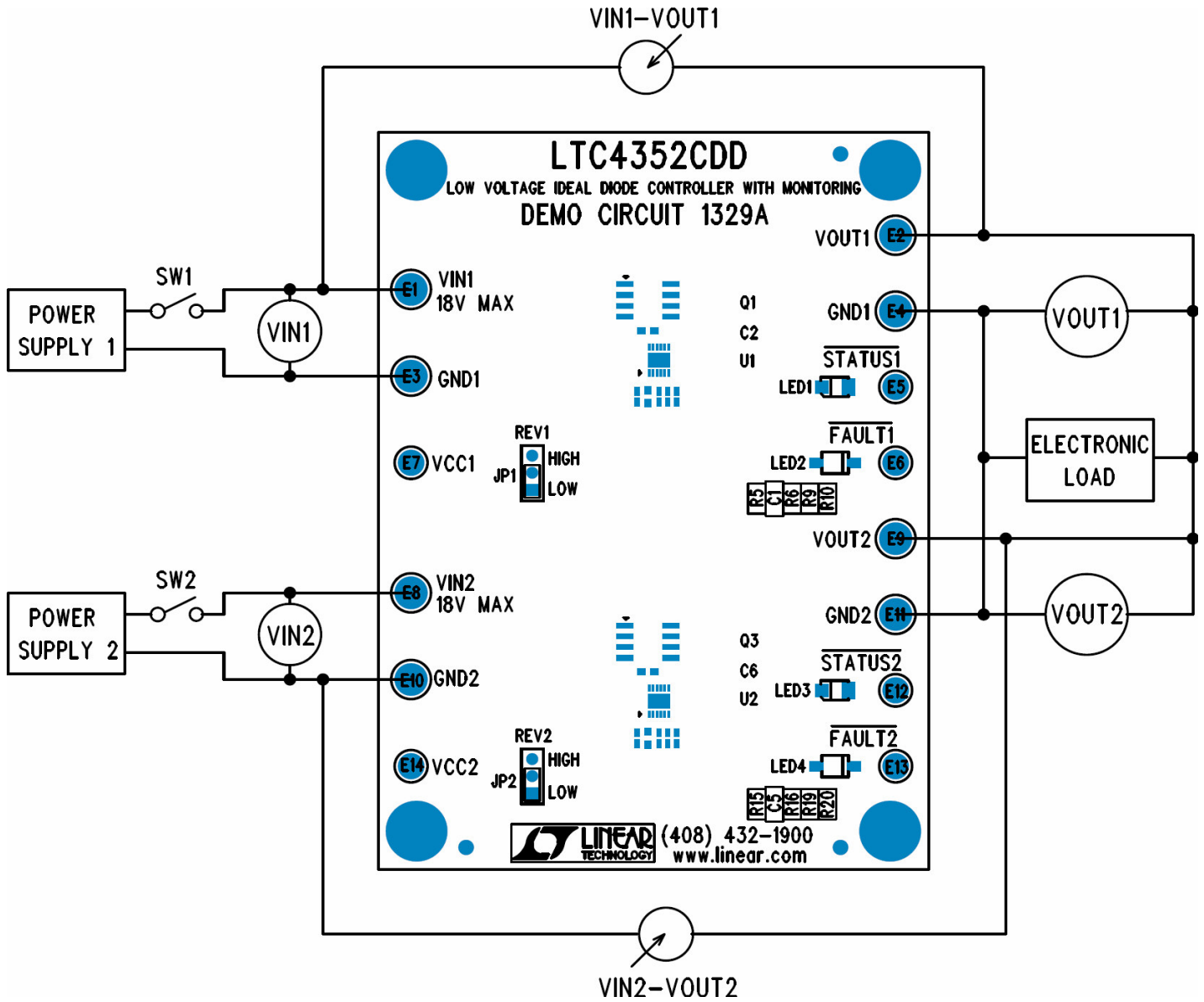
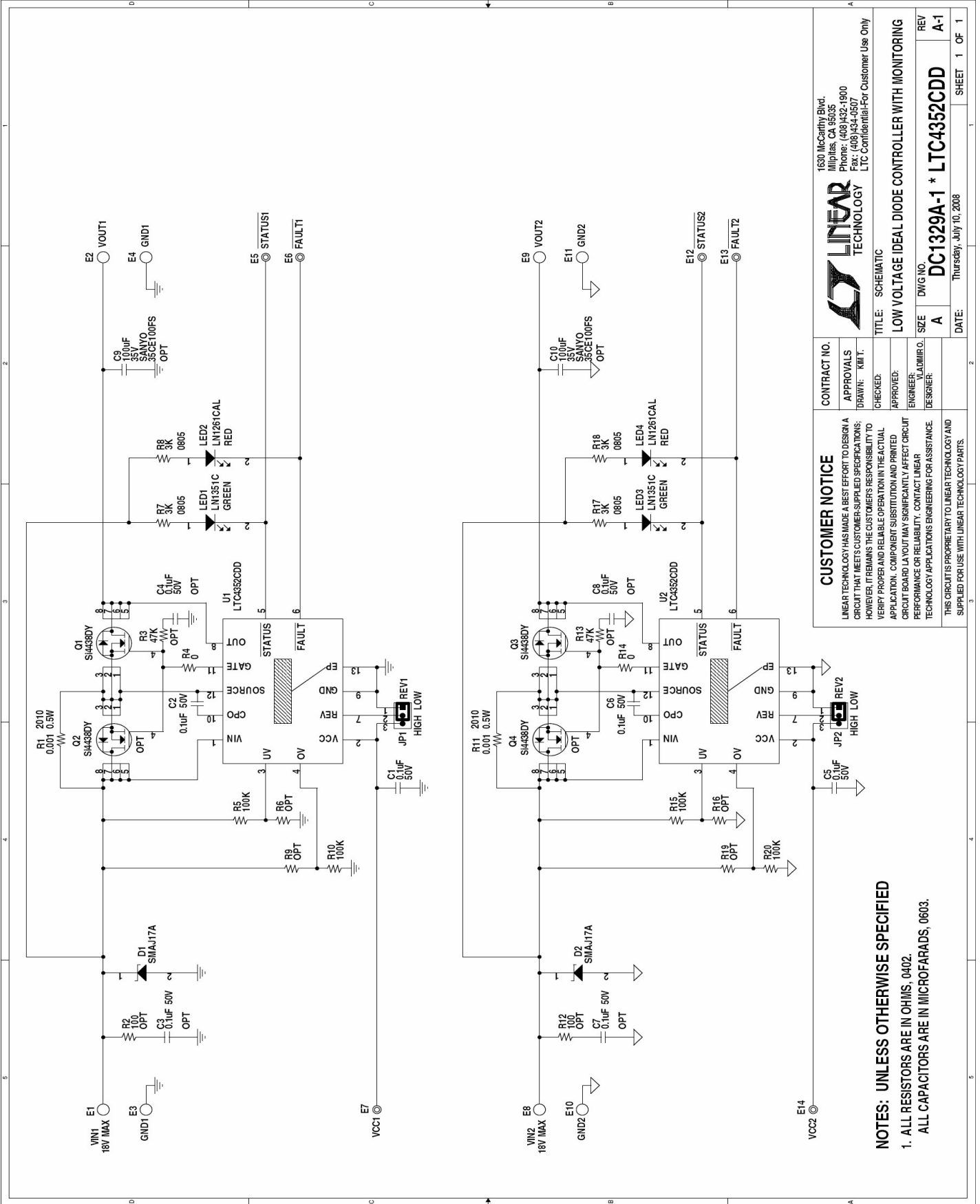

Figure 1. Proper Measurement Equipment Setup



<b>CUSTOMER NOTICE</b>		<b>CONTRACT NO.</b>	
LINEAR TECHNOLOGY HAS MADE A BEST EFFORT TO DESIGN A CIRCUIT THAT MEETS CUSTOMER-SUPPLIED SPECIFICATIONS; HOWEVER, IT REMAINS THE CUSTOMER'S RESPONSIBILITY TO VERIFY PROPER AND RELIABLE OPERATION IN THE ACTUAL APPLICATION. COMPONENT SUBSTITUTION AND PRINTED CIRCUIT BOARD LAYOUT MAY SIGNIFICANTLY AFFECT CIRCUIT PERFORMANCE OR RELIABILITY. CONTACT LINEAR TECHNOLOGY APPLICATIONS ENGINEERING FOR ASSISTANCE.		APPROVALS DRAWN: K.M.T.	
THIS CIRCUIT IS PROPRIETARY TO LINEAR TECHNOLOGY AND SUPPLIED FOR USE WITH LINEAR TECHNOLOGY PARTS.		CHECKED:	
		ENGINEER:	
		DESIGNER:	
		TITLE: SCHEMATIC	
		LOW VOLTAGE IDEAL DIODE CONTROLLER WITH MONITORING	
		DWG NO. DC1329A-1 * LTC4352CDD	
		REV A-1	
		DATE: Thursday, July 10, 2008	
		SHEET 1 OF 1	

**NOTES: UNLESS OTHERWISE SPECIFIED**

1. ALL RESISTORS ARE IN OHMS, 0402.
- ALL CAPACITORS ARE IN MICROFARADS, 0603.