

THIS DRAWING IS UNPUBLISHED.

RELEASED FOR PUBLICATION

20

© COPYRIGHT 20

BY -

ALL RIGHTS RESERVED.

LOC HQ

DIST 00

REVISIONS

P	LTR	DESCRIPTION	DATE	DWN	APVD
	HI	REVISED PER ECO-11-005027	12MAR2011	RK	HMR

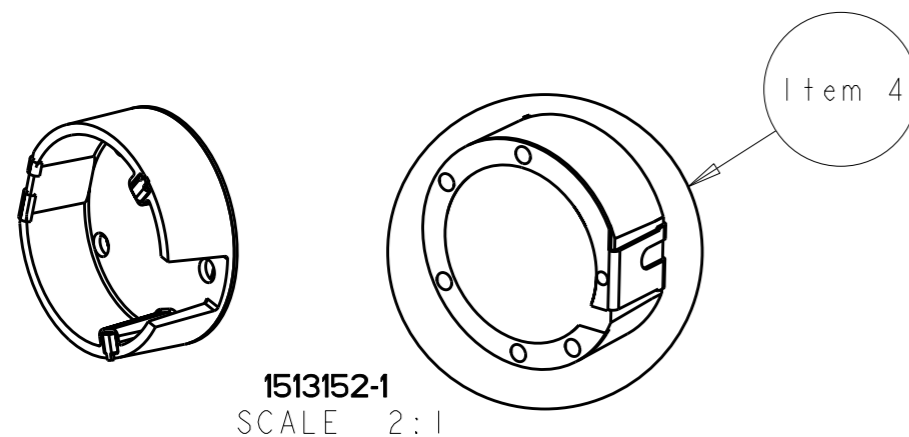
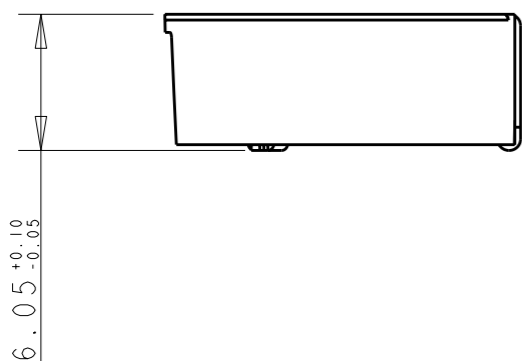
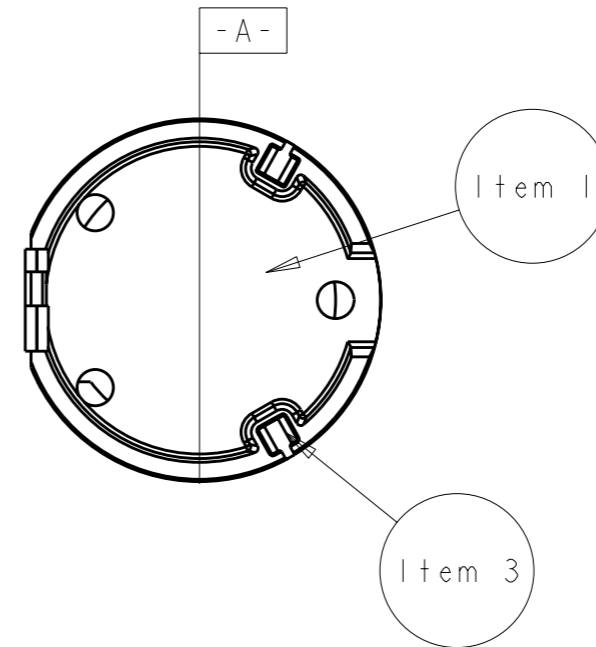
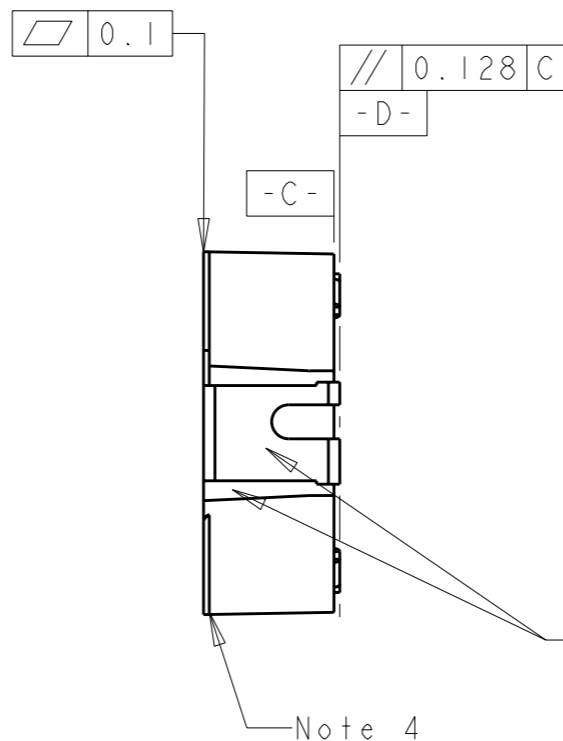
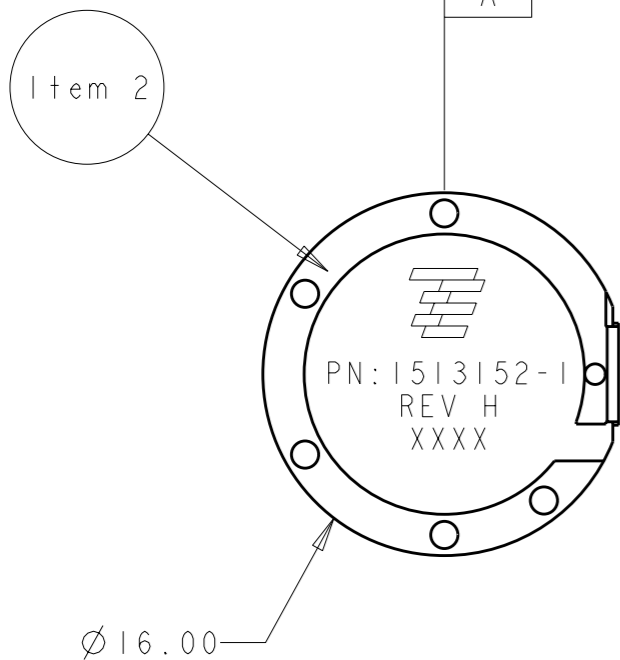

1513152-1
SCALE 2:1

NOTES:

1. Material-Dow Questra WA550, 30% glass filled, natural color.
2. Item 2 insert molded into item 1. Flat side wall of Item 2 to be flush with flat side wall in Item 1.
3. Item 3 press fit into item 4.
4. No air gaps between components.
5. General tolerance block applies unless otherwise specified.
6. Part will be identified with part number, rev letter, TE logo and 4 digit date code. 1st two digits for the year and the 2nd two digits for the week.

ITEM NO.	QTY.	DESCRIPTION
1	1	OVERMOLDED METAL RING
2	1	METAL RING
3	2	ANCHOR TAB
4	1	ASSEMBLY

THIS DRAWING IS A CONTROLLED DOCUMENT.		DWN DJL	11JAN2005	STE TE Connectivity	
DIMENSIONS: mm		CHK -	APVD -		
TOLERANCES UNLESS OTHERWISE SPECIFIED:		PRODUCT SPEC -		SIZE A3	
0 PLC ±0.10	1 PLC ±0.10	APPLICATION SPEC -		CAGE CODE 300779	DRAWING NO C-1513152
2 PLC ±0.05	3 PLC ±0.05	WEIGHT -		RESTRICTED TO -	
4 PLC ±0.01	ANGLES ±1°	CUSTOMER DRAWING		SCALE 4:1	SHEET 1 OF 1
MATERIAL -	FINISH -			REV HI	