

FCI PART NUMBER	DESCRIPTION	NOTES
10123416-XXXXLF	CONTROLLER TO CONTROLLER CONFIGURATION	SEE TABLE 2

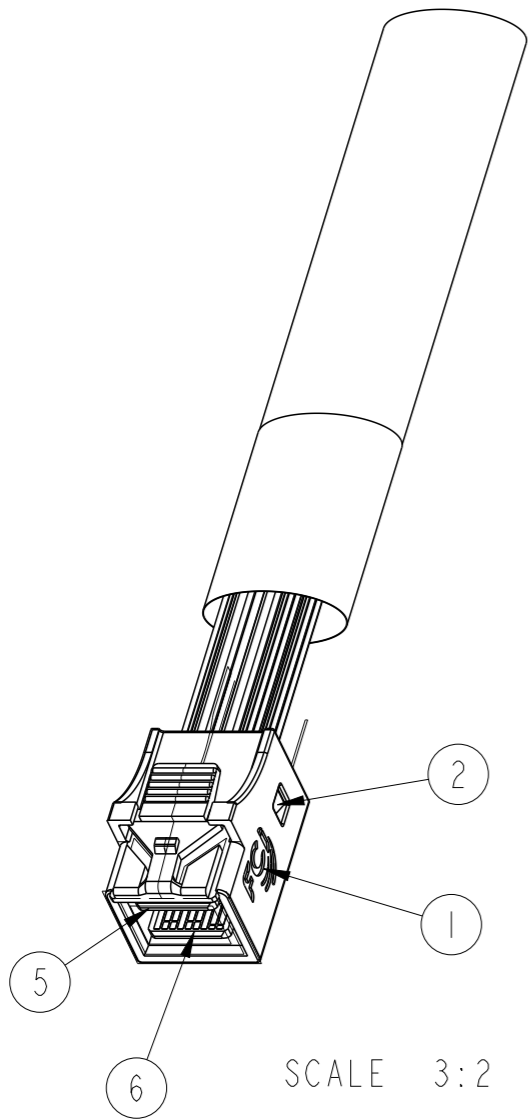

TABLE 1 - BILL OF MATERIALS

ITEM	DESCRIPTION	QTY	NOTES
1	mSAS HD INTERNAL HOUSING- SHORT	2	
2	mSAS HD INTERNAL PCB INSERT- SHORT	2	
3	FLAT RIBBON CABLE GPPG (30 AWG)	A/R	SEE TABLE 2
4	SIDE BAND FLAT RIBBON CABLE (30 AWG)	A/R	
5	mSAS HD INTERNAL LOWER (A-B) PCB	2	
6	mSAS HD INTERNAL UPPER (C-D) PCB	2	
7	PLASTIC BRAID	A/R	
8	ACETATE TAPE 20mm BLACK	A/R	
9	LABEL	1	SEE NOTE 5
10	3525 LOCTITE	A/R	NOT SHOWN

spec ref	-	dr	Andy Wu	2013/01/03	projection	mm	size	A3	scale	1:1	
tolerance std	ISO 406 ISO 1101	eng	Andy Wu	2013/01/17			ecn no	ELX-N-13885-1			
	TOLERANCES UNLESS OTHERWISE SPECIFIED	chr	-	-			rel level	Released			
surface	✓	appr	Roger Cheng	2013/01/20	product family	-	dwg no	10123416		rev	B
ISO 1302	linear	0.X	±0.3		mSAS HD INTERNAL (4i)		cat. no. - Product - Customer Drw	sheet 1 of 4			
		0.XX	±0.10		CABLE ASSEMBLY- 6 Gb/s, short type						
	angular	0°	±2°		www.fci.com						



FCI PART NUMBER	DESCRIPTION	NOTES
10123416-XXXXLF	CONTROLLER TO CONTROLLER CONFIGURATION	SEE TABLE 2

TABLE 2- CABLE PART NUMBER LIST			
PART NUMBER	"DIM L" CABLE LENGTH (METERS)	AWG	NOTES
10123416-2030LF	0.3	30	CONTROLLER TO CONTROLLER WIRING CONFIGURATION (SHEET 2) ---- (SEE SHEET 4 FOR ALL NOTES)
10123416-2040LF	0.4	30	
10123416-2050LF	0.5	30	
10123416-2060LF	0.6	30	
10123416-2070LF	0.7	30	
10123416-2080LF	0.8	30	
10123416-2090LF	0.9	30	
10123416-2100LF	1.0	30	

NOTE:

1. ALL CABLE PERFORMANCE COMPLIANCE SAS2.1
2. CABLE MORE THAN 1.0 METER COULD NOT MEET SAS2.1 INSERTION LOSS -6dB MAX.

spec ref	-	dr	Andy Wu	2013/01/03	projection	mm	size	A3	scale	1:2
tolerance std	ISO 406 ISO 1101	eng	Andy Wu	2013/01/17		← →	ecn no	ELX-N-13885-1		
	TOLERANCES UNLESS OTHERWISE SPECIFIED	chr	-	-			rel level	Released		
surface	ISO 1302	appr	Roger Cheng	2013/01/20	product family	-	dwg no	10123416	rev	B
	linear					mSAS HD INTERNAL (4i)				
	angular				www.fci.com	CABLE ASSEMBLY- 6 Gb/s, short type				
					cat. no.	-	Product - Customer Drw	sheet 2 of 4		



Copyright FCI.

FCI PART NUMBER	DESCRIPTION	NOTES
10123416-XXXXLF	CONTROLLER TO CONTROLLER CONFIGURATION	SEE TABLE 2

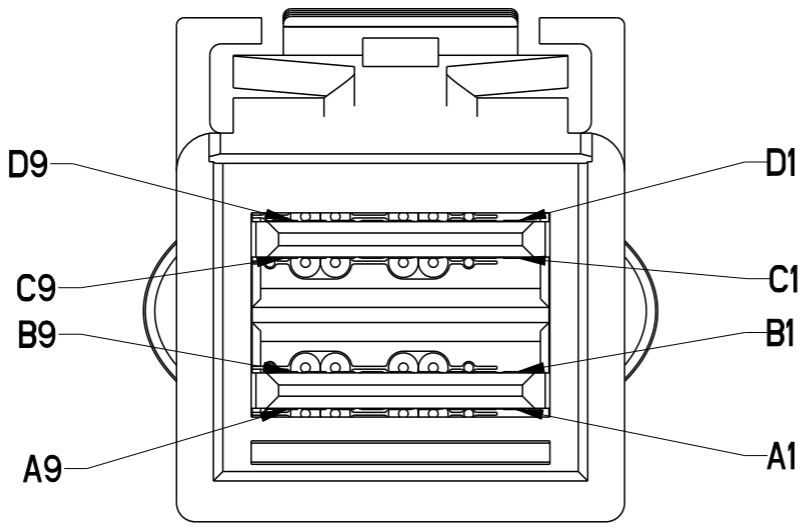

SCALE 5:1

LEGEND	
	HIGH-SPEED SERIAL DIFFERENTIAL PAIRS
	SIGNAL RETURN
	SIDEBAND SIGNAL

WIRING LIST (CONTROLLER TO CONTROLLER)				
END P1 (CONTROLLER)			END P2 (CONTROLLER)	
POSITION	SYMBOL		POSITION	SYMBOL
D9	GROUND	-----	B9	GROUND
D8	Tx2-		B8	Rx2-
D7	Tx2+		B7	Rx2+
D6	GROUND	-----	B6	GROUND
D5	Tx0-		B5	Rx0-
D4	Tx0+		B4	Rx0+
D3	GROUND	-----	B3	GROUND
D2	SIDEBAND 6		B2	SIDEBAND 1
D1	SIDEBAND 5		C2	SIDEBAND 2
C1	SIDEBAND 4		B1	SIDEBAND 3
C2	SIDEBAND 2		D1	SIDEBAND 5
C3	GROUND	-----	A3	GROUND
C4	Tx1+		A4	Rx1+
C5	Tx1-		A5	Rx1-
C6	GROUND	-----	A6	GROUND
C7	Tx3+		A7	Rx3+
C8	Tx3-		A8	Rx3-
C9	GROUND	-----	A9	GROUND
B9	GROUND	-----	D9	GROUND
B8	Rx2-		D8	Tx2-
B7	Rx2+		D7	Tx2+
B6	GROUND	-----	D6	GROUND
B5	Rx0-		D5	Tx0-
B4	Rx0+		D4	Tx0+
B3	GROUND	-----	D3	GROUND
B2	SIDEBAND 1		D2	SIDEBAND 6
B1	SIDEBAND 3		C1	SIDEBAND 4
A1	SIDEBAND 7		A2	SIDEBAND 0
A2	SIDEBAND 0		A1	SIDEBAND 7
A3	GROUND	-----	C3	GROUND
A4	Rx1+		C4	Tx1+
A5	Rx1-		C5	Tx1-
A6	GROUND	-----	C6	GROUND
A7	Rx3+		C7	Tx3+
A8	Rx3-		C8	Tx3-
A9	GROUND	-----	C9	GROUND

spec ref	-	dr	Andy Wu	2013/01/03	projection	mm	size	A3	scale	1:1
tolerance std	ISO 406 ISO 1101	eng	Andy Wu	2013/01/17		← →	ecn no	ELX-N-13885-1	rel level	Released
TOLERANCES UNLESS OTHERWISE SPECIFIED		chr	-	appr						
surface	ISO 1302	linear	0.X	±0.3		mSAS HD INTERNAL (4i)	dwg no	10123416	rev	B
			0.XX	±0.10						
			0.XXX	±0.005						
		angular	0°	±2°	www.fci.com	cat. no.	-	Product - Customer Drw	sheet 3 of 4	

Copyright FCI.

NOTES:

- 1. MATERIAL:  
HOUSINGS: MODIFIED POLYPHENYLENE ETHER  
PADDLE CARD: PRINTED CIRCUIT SUBSTRATE  
HEAT SHRINK TUBE: POLYOLEFIN  
EPOXY LOCTITE
- 2. THIS PRODUCT MEETS THE RESTRICTION OF HAZARDOUS SUBSTANCES IN ELECTRICAL AND ELECTRONIC EQUIPMENT (RoHS) DIRECTIVE (2002/95/EC)
- 3. THIS DIMENSION IS A FINISHED PRODUCT LENGTH.
- 4. UNLESS OTHERWISE SPECIFIED ASSEMBLED LENGTH TOLERANCE IS TO BE:  
"DIM L" < 1 METER = ±15mm  
"DIM L" 1 METER TO 10 METERS = ± 2% OF "DIM L"
- 5. UNLESS OTHERWISE SPECIFIED LABEL POSITION IS TO BE 95mm FROM REAR OF PI CONNECTOR.  
LABEL DETAILS:  
MANUFACTURER CODE OR NAME COUNTRY OF ORIGIN  
CUSTOMER P/N OR FCI P/N  
REVISION  
DATE CODE (YYYY/MM/DD FORMAT) - SERIAL NUMBER  
  
FONT SHALL BE CLEARLY VISIBLE AND BLACK IN COLOR.
- 6. ALL CABLE ASSEMBLIES SHALL BE 100% TESTED FOR CONTINUITY AS DEFINED IN WIRING LIST.
- 7. ALL CABLE ASSEMBLIES SHALL BE 100% HI-POT TESTED BH APPLYING 300V DC FOR A MINIMUM OF 10ms.
- 8. IMPEDANCE: 100Ω DIFFERENTIAL.
- 9. OTHER TESTING PERFORMED AS REQUIRED BY PRODUCT SPECIFICATION: GS-12-650.
- 10. PACKAGE AND LABEL CABLE ASSEMBLIES PER GS-14-1272.
- 11. A "△" SYMBOL WILL BE NEXT TO ANY DIMENSION, VIEW, OR NOTE WHICH HAS BEEN MODIFIED WITH THE CURRENT DRAWING REVISION. THE CURRENT REVISION WILL BE SHOWN IN THE SYMBOL.
- 12. "HLF" PRODUCT NUMBERS DESIGNATE THE USE OF HALOGEN FREE RAW CABLE.
- 13. HALOGEN FREE RAW CABLE CAN BE USED AS A SUBSTITUTE ON NON-HF PRODUCT NUMBERS.
- 14. PART NUMBER/SUPPLIER SUBSTITUTION IS NOT ALLOWED.



Copyright FCI.

spec ref -		dr	Andy Wu	2013/01/03	projection 	mm 	size	A3	scale	1:1	
tolerance std ISO 406 ISO 1101		TOLERANCES UNLESS OTHERWISE SPECIFIED					eng	Andy Wu	2013/01/17	ecn no	ELX-N-13885-1
surface							chr	-	-	rel level	Released
ISO 1302	linear	0.X	±0.3		product family		-	dwg no 10123416	rev B		
		0.XX	±0.10		mSAS HD INTERNAL (4i)						
		0.XXX	±0.005		CABLE ASSEMBLY- 6 Gb/s, short type						
	angular	0°	±2°	www.fci.com	cat. no.	-	Product - Customer Drw	sheet 4 of 4			