

THIS DRAWING IS UNPUBLISHED. RELEASED FOR PUBLICATION
 © COPYRIGHT BY TYCO ELECTRONICS CORPORATION. ALL RIGHTS RESERVED.

Loc		DIST		REVISIONS			
P	LTR	DESCRIPTION	DATE	DWN	APVD		
ES	00	J	REVISED PER ECO-10-013278	27JUL10	HMR	MW	

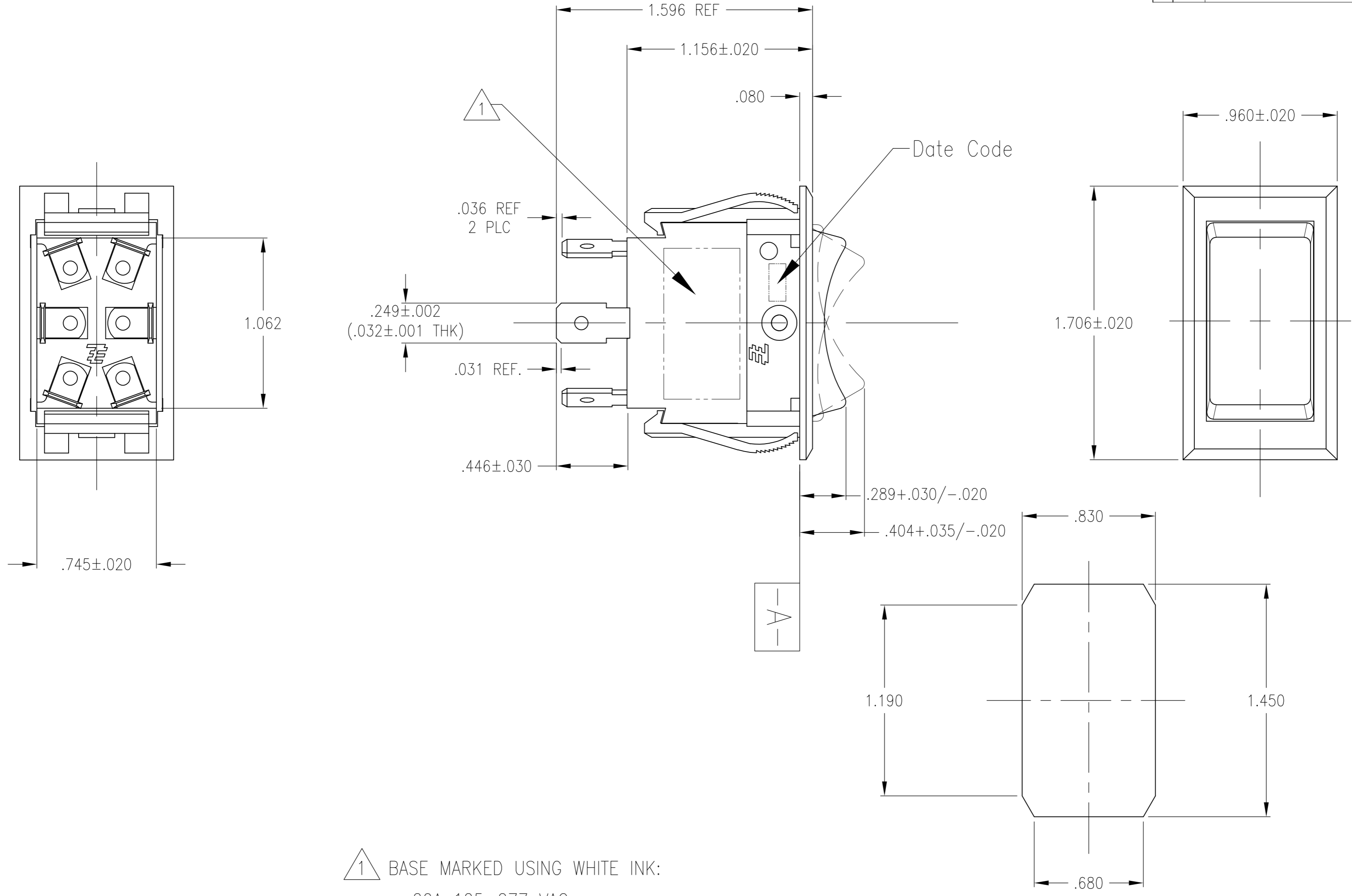

△ BASE MARKED USING WHITE INK:
 20A 125-277 VAC
 2H.P. 250 VAC
 Ⓣ 2H.P. 125 VAC cRUUS
 TAIWAN

- RECOMMENDED PANEL THICKNESS: .040 - .140
- COMPONENT RECOGNIZED TO US & CANADIAN STANDARDS, UL FILE NO. E46765.

RECOMMENDED PANEL CUT OUT DIMENSIONS

Ⓣ PART NUMBER 1517141-1, 6517141-1.
 6517141-1 IS ROHS COMPLIANT VERSION OF 1517141-1

THIS DRAWING IS A CONTROLLED DOCUMENT.		DWN Z.JOANNA 12FEB04	Tyco Electronics Corporation Shanghai, China	
DIMENSIONS: INCHES		CHK Y.CHARLES 16FEB04	NAME D.P. ROCKER ON-OFF-ON	
TOLERANCES UNLESS OTHERWISE SPECIFIED:		APVD M.SHINDO 16FEB04	SIZE A2	
0 PLC ± -		PRODUCT SPEC	CAGE CODE 00779	DRAWING NO 1517141
1 PLC ± -		APPLICATION SPEC	RESTRICTED TO	
2 PLC ± -			SCALE 1:1	SHEET 1 OF 1
3 PLC ± .005			REV J	
4 PLC ± -				
ANGLES ± -				
FINISH		WEIGHT		
-				
CUSTOMER DRAWING				