

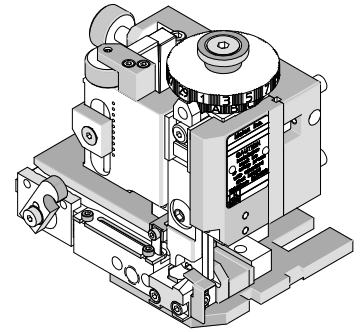

# Mini-Mac Applicator Specification Sheet Order No. 63891-6100



## FEATURES

- Directly adapts to most automatic wire processing machines
- Applicator designed to industry standard mounting and shut height 135.80mm (5.346")
- Quick set-up time; plus the crimp height, track and feed adjustments can be set without removing the applicator from the press
- Fine adjustment allows users to achieve target with little effort by adjusting in increments of .015mm (.0006") for conductor crimp height and .063mm (.0025") for insulation height
- Independent adjustment rings allow users to quickly adjust the conductor or insulation crimp height without affecting each other.

## SCOPE

Products: Sabre™ Female Flat Blade Crimp Terminal, 14-16 AWG.

Terminal Series No.	Terminal Order No.	Wire Size		Insulation Diameter		Strip Length	
		AWG	mm <sup>2</sup>	mm	In.	mm	In.
43374	43374-1001	14-16	2.00-1.30	3.05-4.57	.120-.180	3.96-5.54	.156-.218
		18 (2)	0.80 (2)	2.80 (2)	.110 (2)	3.96-5.54	.156-.218
43375	43375-1001	14-16	2.00-1.30	3.05-4.57	.120-.180	3.96-5.54	.156-.218
		18 (2)	0.80 (2)	2.80 (2)	.110 (2)	3.96-5.54	.156-.218

This Applicator provides a standard 4.80mm wide insulation crimp.  
For special narrow insulation crimp when using 6313, 43275, and 41644-24 housings, use 63891-7000 applicator.

## DEFINITION OF TERMS

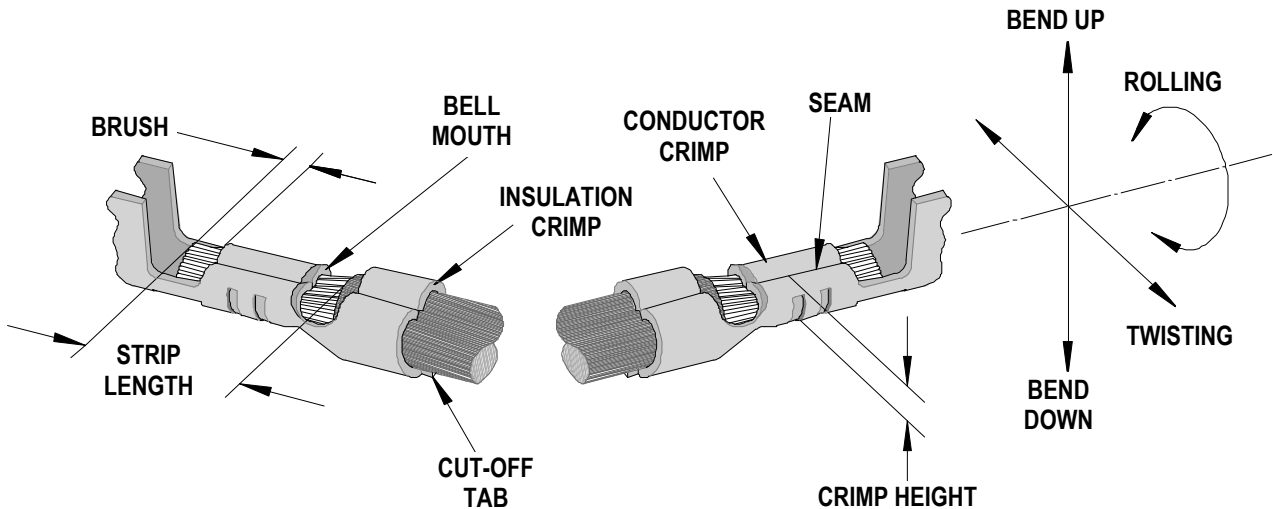

The above terminal drawing is a generic terminal representation. It is not an image of a terminal listed in the scope.

## CRIMP SPECIFICATIONS

Terminal Series No.	Bell mouth		Cut-off Tab Maximum		Conductor Brush	
	mm	In.	mm	In.	mm	In.
43374	0.20-0.50	.008-.020	0.20	.008	0.50	.020
43375	0.20-0.50	.008-.020	0.20	.008	0.50	.020

Terminal Series No.	Bend up	Bend down	Twist	Roll	Punch Width (Ref)				Seam Seam shall not be open and no wire allowed out of the crimping area
					Conductor		Insulation		
	Degree		Degree		mm	In	mm	In	
43374	3	3	4	8	2.50	.098	4.80	.189	
43375	3	3	4	8	2.50	.098	4.80	.189	

After crimping, the conductor profile should measure the following.

Terminal Series No.	Wire Size		Conductor Crimp Height		Pull Force Minimum	
	AWG	mm <sup>2</sup>	mm	In.	N	Lb.
43374	14	2.00	1.65-1.75	.065-.069	222.4	50.0
	16	1.30	1.47-1.57	.058-.062	133.4	30.0
	18 (2)	0.80 (2)	1.47-1.57	.058-.062	88.9	20
43375	14	2.00	1.65-1.75	.065-.069	222.4	50.0
	16	1.30	1.47-1.57	.058-.062	133.4	30.0
	18 (2)	0.80 (2)	1.47-1.57	.058-.062	88.9	20

Pull Force should be measured with no influence from the insulation crimp.

The above specifications are guidelines to an optimum crimp.

**PARTS LIST**

<b>Mini-Mac Applicator 63891-6100</b>				
<b>Item</b>	<b>Order No</b>	<b>Engineering No.</b>	<b>Description</b>	<b>Quantity</b>
<b>Perishable Tooling</b>				
	63891-6170	63891-6170	Tool Kit (All "Y" Items)	REF
1	11-18-5418	60843A106	Conductor Punch	1 Y
2	63445-2562	63445-2562	Conductor Anvil	1 Y
3	11-18-5422	60843A108	Insulation Punch	1 Y
4	63445-4808	63445-4808	Insulation Anvil	1 Y
5	63443-0002	63443-0002	Front Cut-Off Plunger	1 Y
6	63443-0012	63443-0012	Cut-off Plunger Retainer	1 Y
<b>Other Components</b>				
7	11-18-5007	60800D114	Hold Down Plunger Spring	1
8	11-18-5115	60805A119	Wire Stop/Stripper	1
9	11-18-5410	60832A141	Hold Down Block	1
10	11-18-5411	60832A142	Spring Retainer	1
11	11-18-5412	60832A143	Hold Down Plunger	1
12	11-18-5416	60842A115	Tooling Washer	1
13	11-18-5420	60843A111	Anvil Mount	1
14	11-18-5421	60843A114	Plunger Striker	1
15	11-18-5442	60843A123	Front Cover	1
16	11-24-1067	4996-4	Cut-off Plunger Spring	1
17	63443-0021	63443-0021	Lower Tooling Key	1
18	63443-6125	63443-6125	Rear Cover	1
19	63803-5105	63803-5105	Conductor Bushing	1
<b>Frame</b>				
20	63801-3201	63801-3201	Top	1
21	63801-3282	63801-3282	Base	1
22	63801-6550	63801-6550	Track	1
<b>Hardware</b>				
23	N/A	N/A	M3 by 6 Long SHCS	4**
24	N/A	N/A	M4 by 10 Long BHCS	2**
25	N/A	N/A	M4 by 12 Long BHCS	2**
26	N/A	N/A	M4 by 12 Long SHCS	2**
27	N/A	N/A	M4 by 25 Long SHCS	2**
28	N/A	N/A	M5 by 10 Long SHCS	1**
29	N/A	N/A	M8 by 20 Long BHCS	1**
30	N/A	N/A	3MM by 6 Long Roll Pin	1**
** Available from an industrial supply company such as MSC (1-800-645-7270).				

### Assembly Drawing

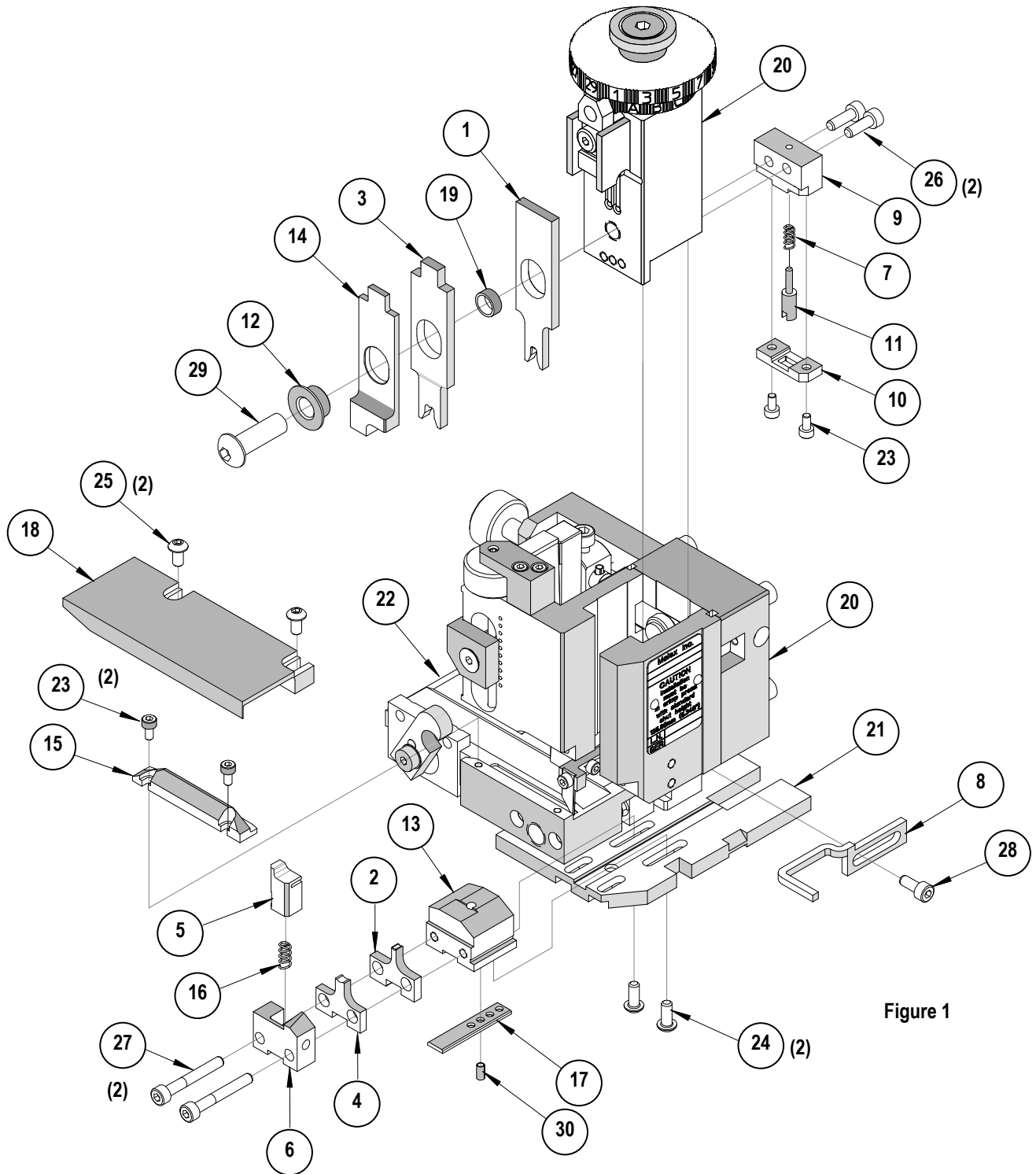

## NOTES

1. Molex recommends an extra perishable tooling kit be maintained at your facility.
2. Verify tooling alignment by manually cycling the press and applicator before crimping under power. Check that all screws are tight.
3. Slugs, terminals, dirt, and oil should be kept clear of work area.
4. Wear safety glasses at all times.
5. For recommended maintenance refer to the Mini-Mac Manual.

**CAUTION:** This applicator should only be used in a press with a shut height of 135.80 mm (5.346"). Tooling damage could result at a lower setting

**CAUTION:** To prevent injury, never operate this applicator without the guards supplied with the press or wire-processing machine in place. Reference the press or wire processing manufacturer's instruction manual.

**CAUTION:** Molex crimp specifications are valid only when used with Molex terminals, applicators and tooling.

## Contact Information

For more information on Molex application tooling please contact Molex at 1-800-786-6539.

<http://www.molex.com>