

THIS COPY IS PROVIDED ON A RESTRICTED BASIS AND IS NOT TO BE USED IN ANY WAY DETRIMENTAL TO THE INTERESTS OF PANDUIT CORP.

NOTES:

1. GRIPS WIRES OF 14-16 GAGE FOR USE WITH QUICK BUILD HARNESS BOARD.
2. FOR USE WITH QUICK-BUILD MOUNTING PEG P/N QB-MOUNT-L.
3. SEE CUSTOMER PRICE SHEET FOR PART NUMBER SUFFIX DESIGNATION FOR PACKAGE SIZE.

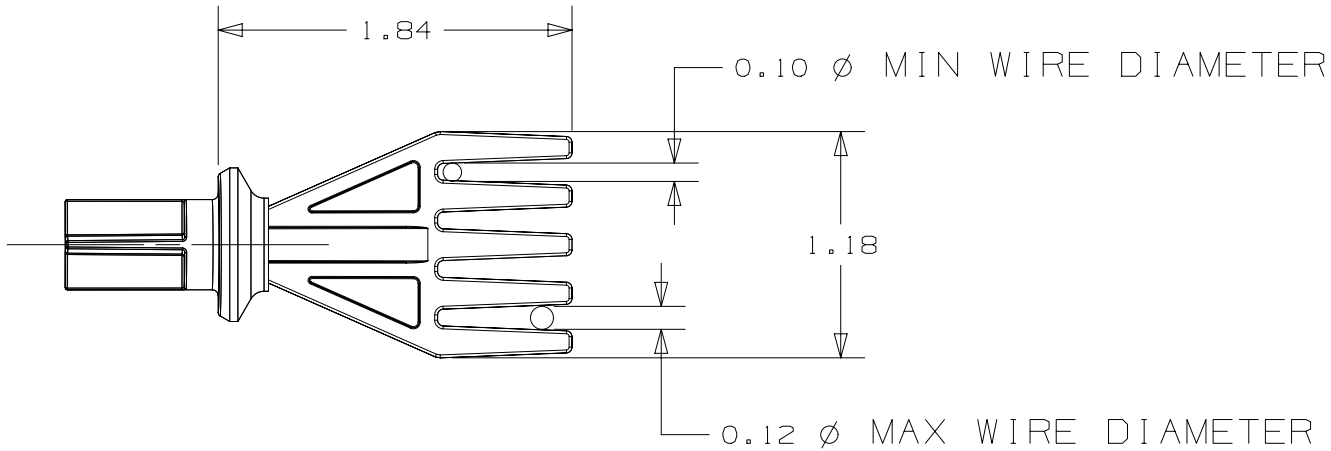
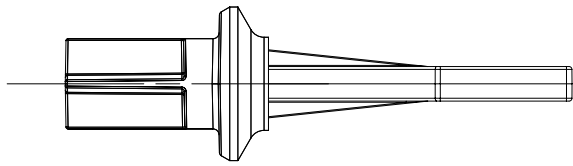

PRODUCT SPEC	PACKAGING SPEC
PART NUMBER QB-WEH1416	WORK INSTRUCTION
INSPECTION INSTRUCTION NUMBER	FMEA & CONTROL PLAN NUMBER

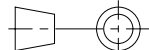
TITLE QUICK BUILD WIRE END HOLDER	
CUSTOMER DRAWING	
ITEM REVISION NAME 14L203GR/05	PANDUIT
DATASET FILE NAME 14L203GR_DC/05	
UNLESS OTHERWISE SPECIFIED, DIMENSIONAL TOLERANCES ARE: IN [mm] .x ± .1 [2.54] .xxx ± .005 [.127] .xx ± .01 [.25] ANGLES ± 5 °	MATERIAL: ABS, BLUE
 THIRD ANGLE PROJECTION	DRAWING NUMBER: 14L203GR_DC

0	10/19/16	DFA	CLW	JHAC	INITIAL RELEASE	GAECN03846
---	----------	-----	-----	------	-----------------	------------

REV	DATE	BY	CHK	APR	DESCRIPTION	ECN	DRAWN BY	DATE	CHK	SCALE	SHT 1 OF 1	SIZE
							DFA	10/19/16	JHAC	NONE		A

D10100DA/20