

Customer Information Sheet

DRAWING No.: H2083-01

IF IN DOUBT - ASK

©

NOT TO SCALE

THIRD ANGLE PROJECTION

ALL DIMENSIONS IN mm

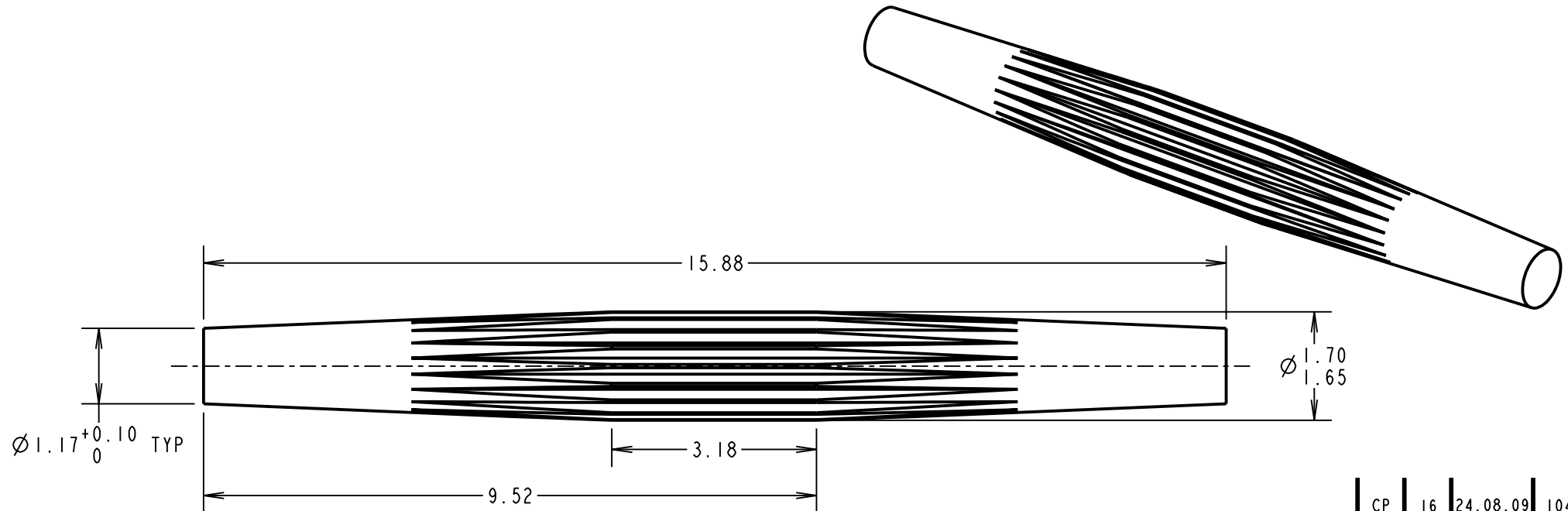

NOTES:

1. RECOMMENDED PANEL THICKNESS = 3.20mm.
2. RECOMMENDED MOUNTING HOLE SIZE FOR PAPER-BASED PANEL = $\varnothing 1.55$
RECOMMENDED MOUNTING HOLE SIZE FOR EPOXY-GLASS PANEL = $\varnothing 1.60$
3. PUNCH & DIE TOOL PART No. = Z2083-00

CP	16	24.08.09	10441
NAME	ISS.	DATE	C/NOTE
APPROVED: C.PENROSE			
CHECKED: R.ADDE			
DRAWN: PETER COLLINS			
CUSTOMER REF.:			
ASSEMBLY DRG:			

HARWIN

HARWIN USA TEL: 603 893 5376 FAX: 603 893 5396 mis@harwin.com	HARWIN Europe (UK) TEL: 023 9231 4545 FAX: 023 9231 4590 mis@harwin.co.uk	HARWIN Asia TEL: +65 6 779 4909 FAX: +65 6 779 3868 mis@harwin.com.sg
--	--	--

THIS DRAWING AND ANY INFORMATION OR DESCRIPTIVE MATTER SET OUT HEREON ARE CONFIDENTIAL AND COPYRIGHT PROPERTY OF THE HARWIN GROUP AND MUST NOT BE DISCLOSED, LOANED, COPIED OR USED FOR MANUFACTURING, TENDERING OR FOR ANY OTHER PURPOSE WITHOUT THEIR WRITTEN PERMISSION.

TOLERANCES
 X. = ± 1 mm
 X.X = ± 0.25 mm
 X.XX = ± 0.10 mm
 X.XXX = ± 0.01 mm
 ANGLES = $\pm 5^\circ$
 UNLESS STATED

MATERIAL:
 BRASS CW614N M
 TO BS EN 12164 (CuZn39Pb3)
FINISH: 100% TIN OVER NICKEL
S/AREA: mm²

TITLE:
 TERMINAL PIN
DRAWING NUMBER:
 H2083-01
 SHT
 2 OF 2