

used for: D-SUB

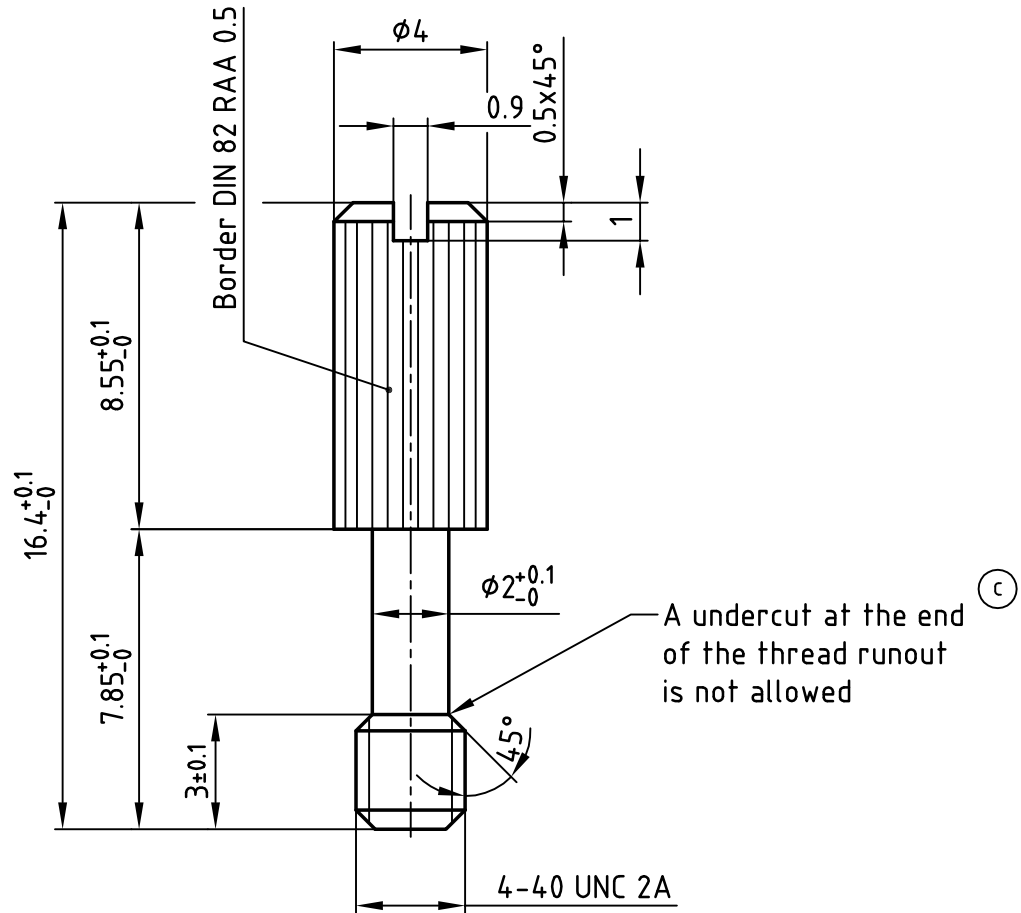

material	finish	part-no.
Steel	2 µm Ni	740-366770
(b) Stainless Steel 1.4305 JIS SUS 303	-----	740-366760

**NOTES:**

1. Part is splint and burrfree
2. Exellent adhesion of surface to the base material
3. Threaded core dimension 4-40UNC: 2.157+-0.1
4. Test equipment measurement: 4-40UNC - 2A



THIS DRAWING MAY NOT BE COPIED OR REPRODUCED IN ANY WAY, AND MAY NOT BE PASSED ON TO A THIRD PARTY WITHOUT WRITTEN PERMISSION.

OWNERSHIP AND COPYRIGHT OF CONEC GmbH

DO NOT ALTER CAD DRAWING BY HAND

finish: (b) SEE TABLE				tolerance DIN ISO 2768-m		scale: 5:1	
2001	date	name		material: SEE TABLE (b)			
drawn	18.05.	E. Mickenbecker		title: <b>JACKSCREW</b> 4.40UNCx16.4mm FOR ROTATING JACKSCREW SYSTEM			
appd.	18.05.	J. Parei					
norm							
d-old							
1 x c	Ä 3037	13.06.2008	Petker	dwg no: AutoCAD 2000		DIN-A	
4 x b	Ä 2518	02.06.06	HS	7401A029A		4	
rev.	description	date	name	part no: SEE TABLE (b)		sh: 1/1	



4

3

2

1