

PART NAME: KNOB

SCALE: 1:1

DATE: 1/22/13

DR. BY JAM

THIS DRAWING IS THE PROPERTY OF DAVIES MOLDING COMPANY, IS SUBMITTED SOLELY AS A DESIGN OR ENGINEERING PROJECT. WE ACCEPT NO RESPONSIBILITY WHATSOEVER FOR THE PRACTICAL APPLICATION OF THE PIECES MADE TO THIS DESIGN.

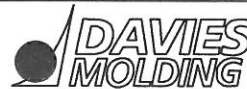

DESIGNERS & MANUFACTURERS  
OF KNOBS, HANDLES, CASES &  
CUSTOM PLASTIC COMPONENTS

P/N

1106

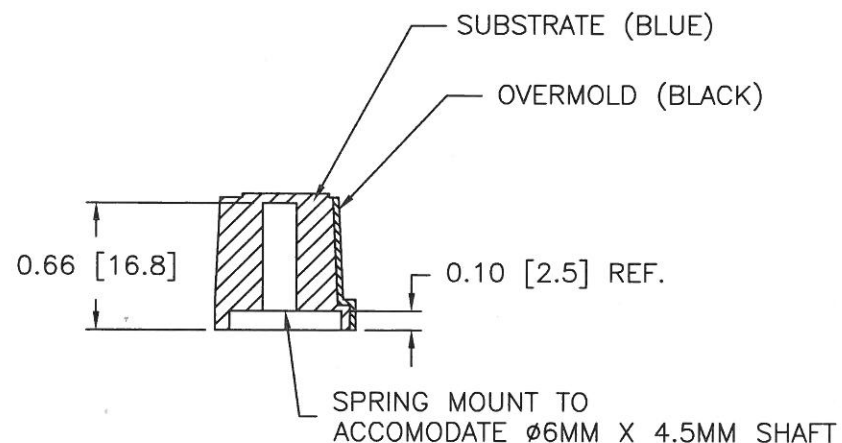
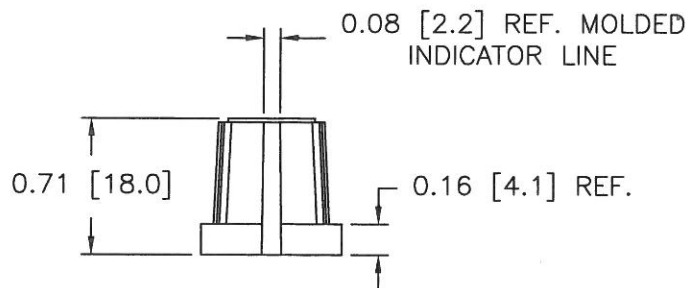
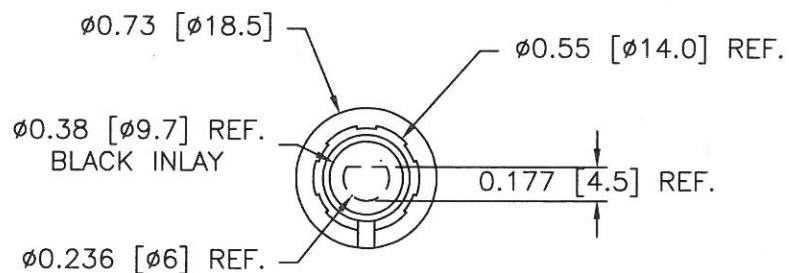

MATERIAL: PP & TPR  
COLOR: BLACK & BLUE