

DIO7195

5.5V Full-Function 2.5A DC Load Switch with Adjustable Current Limit

Features

- Input voltage: 1.8V to 5.5V
- Quiescent supply current 80uA with open load
- Turn-on controlled
- Continuous Current Max: 2.5A
- P-channel MOSFET current-limited architecture
- Under-Voltage Lockout
- Low shutdown current
- Fast current limit response
- Thermal shutdown protection
- Reverse current blocking
- Package: six ball advanced 0.98x1.48mm WLCSP-6

Applications

- Handheld electronic device
- Portable Enterprise / Industrial Devices
- Digital Cameras
- Peripheral Ports and Accessories
- Medical Equipment
- Hot Swap

Descriptions

The DIO7195 are series of load switch that provides full protection to systems and loads that may encounter large current conditions.

A P-channel MOSFET current-limit makes the current prevented, when the MOSFET is off. And the output voltage higher than input in addition. The perfectly thermal shutdown protection that what shuts off the switch to prevent damage to the part when a continuous over-current condition causes excessive heating.

When the switch current reaches the current limit, the parts operate in a constant-current mode to prohibit excessive currents from causing damage.

The DIO7195 does not turn off after a current limit fault, but remains in the constant-current mode indefinitely.

Block Diagram

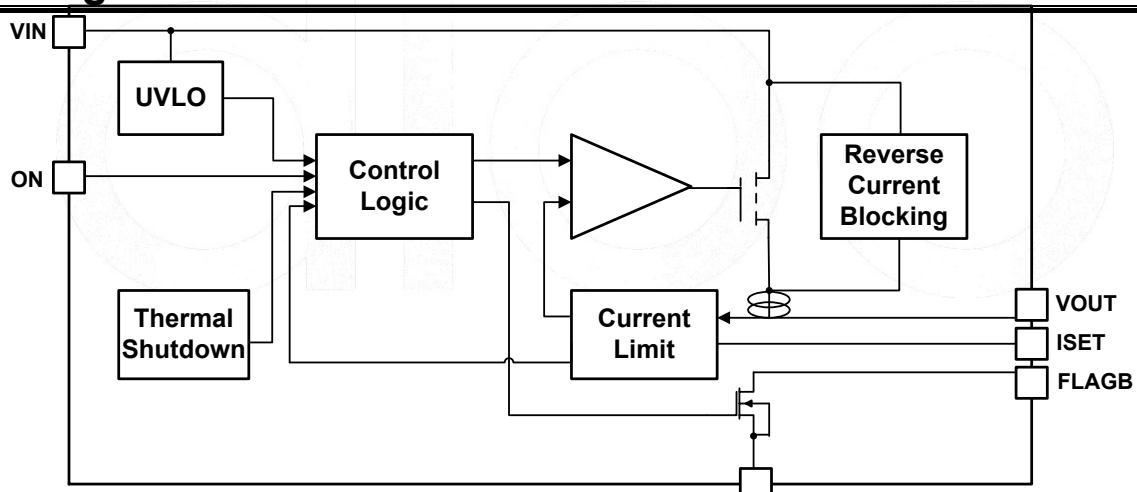

Figure 1 Functional Block Diagram



DIO7195

Ordering Information

Order Part Number	Top Marking		T _A	Package	
DIO7195WL6	7195	Green	-40 to +85°C	WLCSP-6	Tape & Reel, 3000

5.5V Full-Function 2.5A DC Load Switch with Adjustable Current Limit

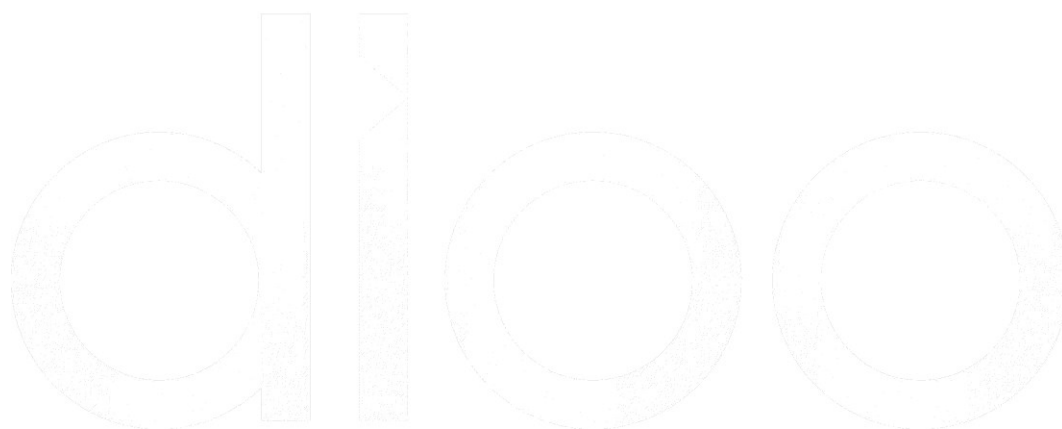

Physical Dimensions: WLCSP-6

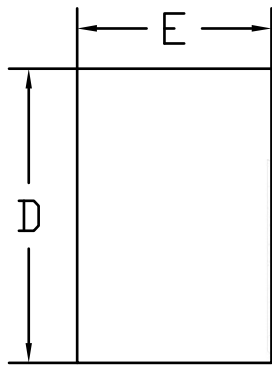

TOP VIEW
(MARK SIDE)

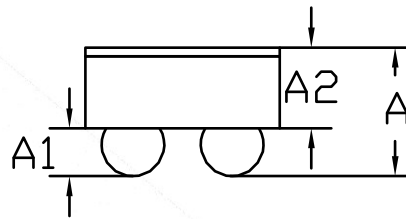

SIDE VIEW

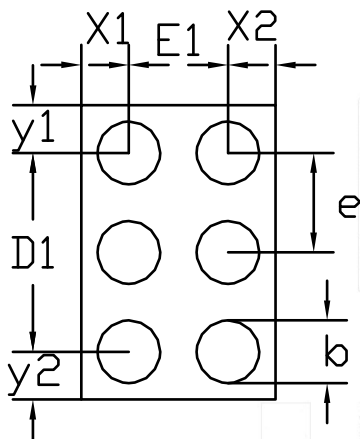

BOTTOM VIEW
(BALL SIDE)

COMMON DIMENSIONS (UNITS OF MEASURE=MILLIMETER)			
SYMBOL	MIN	MON	MAX
A	0.535	0.580	0.625
A1	0.223	0.248	0.273
A2	0.312	0.332	0.352
D	1.450	1.480	1.510
D1	1.000BSC		
E	0.950	0.980	1.010
E1	0.500BSC		
b	0.285	0.310	0.335
e	0.500 BSC		
x1	0.240 REF		
x2	0.240 REF		
y1	0.240 REF		
y2	0.240 REF		



DIO7195

CONTACT US

Dioo is a professional design and sales corporation for high-quality and performance analog semiconductors. The company focuses on industry markets, such as, cell phone, handheld products, laptop, and medical equipment and so on. Dioo's product families include analog signal processing and amplifying, LED drivers and charger IC. Go to <http://www.dioo.com> for a complete list of Dioo product families.

For additional product information, or full datasheet, please contact with our Sales Department or Representatives.

5.5V Full-Function 2.5A DC Load Switch with Adjustable Current Limit

