

## 5V/2.4A Power Bank Solution

### FEATURES

- Dedicated Single Chip Solution for Mobile Power With Minimal Component Count
- 2.4A Continuous Output Current in Boost Mode
- 2.4A Switching Charger Current
- 96% Boost Efficiency (Vbat=4.1V)
- Adaptive to 10mA-2400mA Input Sources
- Battery Disconnection at Output Short
- <10µA Low Battery Leakage Current at HZ Mode During Storage
- Boost Auto Turn-off at No Load and Push Button Turn-on
- Battery Over Current, Over Voltage, Over Temperature and Short Circuit Protections
- Boost Auto Startup with Load Detection
- Prioritized Power Path from Input to Output
- 5V+/-100mV Output Voltage in Boost Mode
- 1.1MHz/0.55MHz Switching Frequencies
- 2.2µH Inductor and Low Profile Ceramic Capacitor
- 4 LEDs Battery Level and Status Indication
- Battery Impedance Compensation
- Full Cycle of Battery Charge Management Preconditioning, Fast Charge, Top off and End of Charge
- Charge Current Foldback at 110°C Die Temperature
- IC Over Temperature Protection at 160°C
- FCQFN 4x4-20 Package

### APPLICATIONS

- Power Bank
- Mobile Power
- Backup Battery Pack
- Standalone Battery Charger with USB Output

### GENERAL DESCRIPTION

ACT2813/ACT2813C is a space-saving and high-performance low-profile single-chip solution for backup battery pack and standalone battery charger. ACT2813/ACT2813C integrates all the functions that a backup battery pack needs, including switching charger, boost converter and LED indication.

ACT2813/ACT2813C operates at 1.1MHz for switching charger and 0.55MHz for boost converter allowing tiny external inductor and capacitors. ACT2813/ACT2813C provides a direct power path from input to output while providing power to switching charger. Output has higher priority than battery charger if the input current limit is reached.

ACT2813/ACT2813C charges battery with full cycle of preconditioning, fast charge with constant current and constant voltage until end of charge. The battery charger is thermally regulated at 110°C with charge current foldback.

ACT2813/ACT2813C boost converter steps battery voltage up to 5V. Boost converter features high efficiency, constant current regulation, short circuit protection and over voltage protection.

ACT2813/ACT2813C provides 3.5mA constant currents to drive 4 LEDs to indicate battery level and charge status. Battery impedance is compensated for battery level indication.

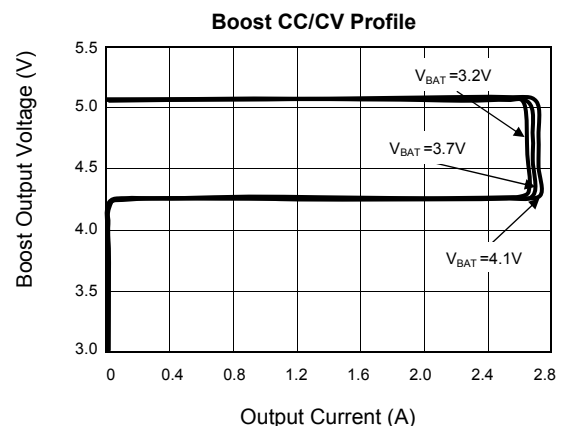
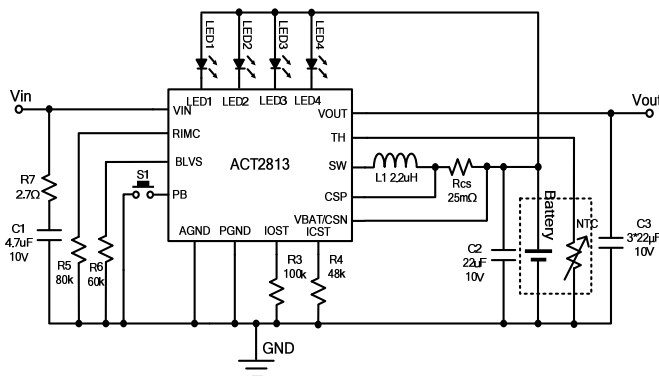

## ORDERING INFORMATION

| PART NUMBER      | OUTPUT  | CHARGE CURRENT | BATTERY VOLTAGE | FLASHLIGHT | TH PIN | PACKAGE      |
|------------------|---------|----------------|-----------------|------------|--------|--------------|
| ACT2813QY-T      | 5V/2.4A | 2.4A           | 4.2V            | No         | Yes    | FCQFN 4x4-20 |
| ACT2813QY-T0435  | 5V/2.4A | 2.4A           | 4.35V           | No         | Yes    | FCQFN 4x4-20 |
| ACT2813CQY-T     | 5V/2.4A | 2.4A           | 4.2V            | Yes        | No     | FCQFN 4x4-20 |
| ACT2813CQY-T0435 | 5V/2.4A | 2.4A           | 4.35V           | Yes        | No     | FCQFN 4x4-20 |

## PIN CONFIGURATION

### TOP VIEW

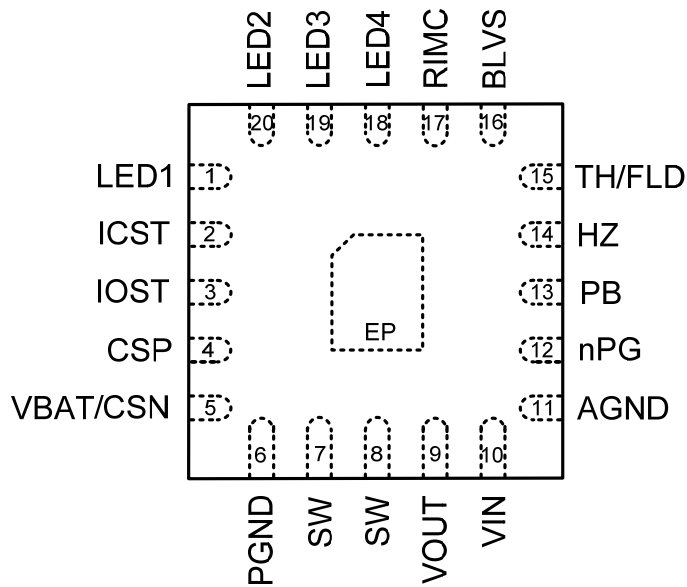

## PIN DESCRIPTIONS

| PIN  | NAME     | DESCRIPTION   |
|------|----------|---|
| 1    | LED1     | Battery level indicator. An internal 3.5mA sink current limit is built in.  |
| 2    | ICST     | Fast charge current setting pin. Connect a resistor from this pin to AGND to set the charge current. The current setting ranges from 1.0A-3.0A.   |
| 3    | IOST     | Output current setting. Connect a resistor from this pin to AGND to set output constant current. The current setting ranges from 1.0A-3.0A.   |
| 4    | CSP      | Positive terminal of charge current sense input. Kevin sense is required with 10nF ceramic capacitor right across CSP and CSN pins.   |
| 5    | VBAT/CSN | Battery input and negative terminal of charge current sense input. Connected to the battery pack positive terminal to provide power in High-Z mode. Bypass to PGND with a high quality ceramic capacitor placed as close to the IC as possible.                             |
| 6    | PGND     | Power ground. PGND is connected to the source of low-side N-channel MOSFET and the MOSFET's gate driver. PGND must be connected to AGND externally through ground plane.  |
| 7, 8 | SW       | Internal switch to output inductor terminal.  |
| 9    | VOUT     | Output pin. Bypass to PGND with a high quality low ESR and ESL ceramic capacitor placed as close to the IC as possible.   |
| 10   | VIN      | USB or AC adaptor input. When VIN is valid, charge and power path is enabled.   |
| 11   | AGND     | Analog ground. AGND must be connected to PGND externally through ground plane.  |
| 12   | nPG      | Drive external P-FET to protect output short circuit and leakage during shutdown. nPG pin is pulled up to VOUT internally. nPG pin is pulled low if VOUT is in the range.   |
| 13   | PB       | Push button input, connect a push button from this pin to AGND, internally pulled up by a 3MΩ resistor to battery. PB starts up boost converter if HZ pin is grounded and VIN is not present. When this pin is pushed for 30ms, LED1-4 indicators are enable for 5 seconds. |
| 14   | HZ       | Boost/high-Z mode enable pin, internally pulled up by a 3MΩ resistor to battery. When HZ pin is pulled ground, boost is enabled if VIN is not present.  |
| 15   | TH/FLD   | TH: ACT2813<br>Temperature sensing input. Connect to battery thermistor terminal. If no use, put 10K pulled down resistor.<br>FLD: ACT2813C<br>Open-drain flashlight driver. A internal switch can handle up to 50mA.   |
| 16   | BLVS     | Battery level voltage shift. Connect a resistor from this pin to AGND to shift the battery LED indication thresholds.   |
| 17   | RIMC     | Battery impedance compensation input. Connect to a resistor from this pin to APNG to program the battery impedance.   |
| 18   | LED4     | Battery level indicator. An internal 3.5mA sink current limit is built in.  |
| 19   | LED3     | Battery level indicator. An internal 3.5mA sink current limit is built in.  |
| 20   | LED2     | Battery level indicator. An internal 3.5mA sink current limit is built in.  |
| 21   | EP       | Exposed pad. Must be soldered to ground on the PCB.   |

## ABSOLUTE MAXIMUM RATINGS<sup>①</sup>

| PARAMETER                              | VALUE       | UNIT |
|--|-------------|------|
| All the Pin to PGND and AGND           | -0.3 to 6.5 | V    |
| Junction to Ambient Thermal Resistance | 40          | °C/W |
| Maximum Power Dissipation              | 2.5         | W    |
| Operating Ambient Temperature          | -40 to 85   | °C   |
| Operating Junction Temperature         | -40 to 150  | °C   |
| Storage Junction Temperature           | -40 to 150  | °C   |
| Lead Temperature (Soldering 10 sec.)   | 300         | °C   |

①: Do not exceed these limits to prevent damage to the device. Exposure to absolute maximum rating conditions for long periods may affect device reliability.

## ELECTRICAL CHARACTERISTICS

 (V<sub>IN</sub> = 5V, T<sub>A</sub> = 25°C, unless otherwise specified.)

| PARAMETER  | TEST CONDITIONS  | MIN   | TYP               | MAX   | UNI<br>T |
|--|--|-------|-------------------|-------|----------|
| <b>Input Current Limit</b>   |  |       |                   |       |          |
| Input Voltage Range  |  | 4.5   |                   | 5.5   | V        |
| V <sub>IN</sub> Over Voltage Protection                                | V <sub>IN</sub> rising, V <sub>IN_OVP</sub>                | 5.5   | 6.0               | 6.5   | V        |
| Input Voltage Validation Time  | V <sub>IN_UVLO</sub> <V <sub>IN</sub> <V <sub>IN_OVP</sub> |       | 32                |       | ms       |
| Leakage Current from V <sub>OUT</sub> to V <sub>IN</sub> in Boost Mode | 3.0V<V <sub>BAT</sub> <4.2V, T <sub>a</sub> =25°C          |       | 0                 | 10    | μA       |
| Battery Discharge Current in High-Z Mode                               | 3.0V<V <sub>BAT</sub> <4.2V, T <sub>a</sub> =25°C          |       | 7.5               | 15    | μA       |
| <b>Power Switches</b>  |  |       |                   |       |          |
| V <sub>IN</sub> -to-V <sub>OUT</sub> FET on Resistance                 |  |       | 60                |       | mΩ       |
| V <sub>OUT</sub> -to-SW FET on Resistance                              |  |       | 45                |       | mΩ       |
| SW-to-PGND FET on Resistance   |  |       | 45                |       | mΩ       |
| <b>Buck Converter</b>  |  |       |                   |       |          |
| Switching Frequency  |  | -15%  | 1.1               | +15%  | MHz      |
| High Side Switch Peak Current Limit                                    |  | 4.5   | 6                 |       | A        |
| Minimum On-time  |  |       | 100               |       | ns       |
| Over Temperature Protection (OTP)                                      | OTP rising   |       | 160               |       | °C       |
| OTP Hysteresis   | OTP falling  |       | 35                |       | °C       |
| <b>Charge Mode</b>   |  |       |                   |       |          |
| Charge Current Setting Range   | R <sub>CS</sub> =25mΩ, R <sub>ICST</sub> =20kΩ—60kΩ        | 1.0   |                   | 3.0   | A        |
| Charge Current Setting (I <sub>CHRG</sub> )                            | R <sub>CS</sub> =25mΩ, R <sub>ICST</sub> =48kΩ             | -10%  | 2.4               | +10%  | A        |
| Thermal Regulation Temperature   |  |       | 110               |       | °C       |
| End of Charge (EOC) Voltage  | ACT2813/ACT2813C   | -0.5% | 4.2               | +0.5% | V        |
|  | ACT2813-T0435/ACT2813C-T0435                               | -0.5% | 4.35              | +0.5% | V        |
| Battery Over Voltage Threshold   | V <sub>BAT</sub> rising                                    |       | 4.6               |       | V        |
| Battery Over Voltage Threshold Hysteresis                              | V <sub>BAT</sub> falling                                   |       | 200               |       | mV       |
| Fast Charge Current  | V <sub>BAT</sub> =3.5V                                     |       | I <sub>CHRG</sub> |       | A        |
| Precondition Charge Current  | 2.4V≤V <sub>BAT</sub> ≤2.8V, Percent of I <sub>CHRG</sub>  |       | 10                |       | %        |
| Precondition Voltage Threshold   | V <sub>BAT</sub> rising                                    |       | 2.8               |       | V        |
| Precondition Voltage Threshold Hysteresis                              |  |       | 130               |       | mV       |

## ELECTRICAL CHARACTERISTICS

 (V<sub>IN</sub> = 5V, T<sub>A</sub> = 25°C, unless otherwise specified.)

| PARAMETER                                    | TEST CONDITIONS   | MIN  | TYP  | MAX  | UNIT |
|--|---|------|------|------|------|
| Low VBAT Charge Current                      | VBAT=1V, R <sub>ICST</sub> =48kΩ                                    |      | 200  |      | mA   |
| EOC Current Threshold                        | VBAT=4.2V, percent of the fast charge current                       |      | 15   |      | %    |
| Charge Restart Voltage Threshold             |   |      | 200  |      | mV   |
| TH Upper Temperature Voltage Threshold       | Cold detect NTC thermistor, ACT2813                                 |      | 1.5  |      | V    |
| TH Lower Temperature Voltage Threshold       | Hot detect NTC thermistor, ACT2813                                  |      | 0.3  |      | V    |
| TH Hysteresis                                | ACT2813   |      | 50   |      | mV   |
| TH Internal Pull-up Current                  | ACT2813   |      | 60   |      | μA   |
| <b>Charge Current Foldback</b>               |   |      |      |      |      |
| Charge Current Reduction Threshold1 of Vout1 | Starting foldback point   | 4.59 | 4.7  | 4.81 | V    |
| Charge Current Reduction Threshold2 of Vout1 | Stop foldback point, R <sub>CS</sub> =25mΩ, R <sub>ICST</sub> =48kΩ |      | 4.57 |      | V    |
| <b>Boost Mode</b>                            |   |      |      |      |      |
| Input Voltage Operation Range                |   | 3.0  |      | 4.5  | V    |
| Switching Frequency                          |   | -15% | 0.55 | +15% | MHz  |
| Input Voltage UVLO                           | VBAT rising   |      | 3.3  |      | V    |
| Input Voltage UVLO Hysteresis                | VBAT falling  |      | 400  |      | mV   |
| Output Voltage (VOUT)                        | T <sub>a</sub> =25°C  | 4.97 | 5.05 | 5.10 | V    |
| Output Voltage Accuracy                      | All conditions  | -3   | VOUT | 2    | %    |
| Output Voltage Transient Response            | 80mA-1A-80mA, 0.1A/us   | 4.75 |      | 5.25 | V    |
|  | 1A-2.4A-1A, 0.1A/us   | 4.7  |      | 5.25 | V    |
| Output Over Voltage Protection               | VOUT rising   |      | 5.7  |      | V    |
| Output Over Voltage Protection Hysteresis    | VOUT falling  |      | 300  |      | mV   |
| Output Current Regulation Range              | R <sub>CS</sub> =25mΩ, R <sub>IOST</sub> =37.4kΩ—113kΩ              | 1.0  |      | 3.0  | A    |
| Output Current                               | R <sub>CS</sub> =25mΩ, R <sub>IOST</sub> =91kΩ                      | -10% | 2.4  | +10% | A    |
| The Maximum Voltage Across VRcs              | All conditions  |      | 200  |      | mV   |
| Minimum On-Time                              |   |      | 100  |      | ns   |
| Low Side Switch Peak Current Limit           | VBAT=3.6V, VOUT=5V  | 5.6  | 6.8  |      | A    |

## ELECTRICAL CHARACTERISTICS

( $V_{IN} = 5V$ ,  $T_A = 25^\circ C$ , unless otherwise specified.)

| PARAMETER  | TEST CONDITIONS  | MIN | TYP  | MAX | UNIT       |
|--|--|-----|------|-----|------------|
| Soft-Startup Time  |  |     | 400  |     | $\mu s$    |
| Under Voltage Protection (UVP Threshold)                   | VOUT falling   |     | 4.25 |     | V          |
|  | VOUT rising  |     | 4.6  |     | V          |
| UVP Blanking Time During Startup                           |  |     | 3    |     | ms         |
| UVP Sense Detection Time                                   | VOUT falling   |     | 20   |     | $\mu s$    |
| Restart After UVP  | Hiccup mode  |     | 2    |     | s          |
| Light Load Current Shut off Threshold                      | VBAT=3.7V, Rcs=25m $\Omega$ , R <sub>I<sub>OST</sub></sub> =91k $\Omega$ |     | 40   | 100 | mA         |
| Light Load Current Detect Time                             |  |     | 16   |     | s          |
| HZ Pin High Voltage  | HZ voltage rising  |     | 0.9  | 1.4 | V          |
| HZ Pin Low Voltage   | HZ voltage falling   | 0.4 | 0.75 |     | V          |
| HZ Internal Pull-up Resistor                               |  |     | 3    |     | M $\Omega$ |
| PB Turn off Boost Time                                     | ACT2813  |     | 1.5  |     | s          |
| PB Turn on Boost Time                                      |  |     | 30   |     | ms         |
| <b>Mode Transition</b>                                     |  |     |      |     |            |
| Transition Waiting Time between Charge Mode and Boost Mode | TRANTIME   |     | 2    |     | s          |
| <b>Battery Level Indication</b>                            |  |     |      |     |            |
| Battery Impedance Compensation Range                       |  | 40  |      | 500 | m $\Omega$ |
| Battery Impedance Compensation                             | Rcs=25m $\Omega$ , R <sub>IMC</sub> =200k $\Omega$                       |     | 200  |     | m $\Omega$ |
| PB Deglitch Time   |  |     | 30   |     | ms         |
| PB High Input Voltage                                      | PB voltage rising  |     | 0.9  | 1.4 | V          |
| PB Low Input Voltage                                       | PB voltage falling   | 0.4 | 0.75 |     | V          |
| PB Internal Pull-up Resistor                               |  |     | 3    |     | M $\Omega$ |
| LED Indication Time  | PB is pushed and released  |     | 5    |     | s          |
| LED Flash Frequency  | Charging, LED flash 1s on and 1s off                                     |     | 0.5  |     | Hz         |
| <b>Flashlight Driver</b>                                   |  |     |      |     |            |
| Flashlight Driver Current                                  | ACT2813C, the current at FLD pin   |     | 50   |     | mA         |
| PB Turn on Flashlight Time                                 | ACT2813C   |     | 3.0  |     | s          |
| PB Turn off Flashlight Time                                | ACT2813C   |     | 3.0  |     | s          |

## FUNCTIONAL BLOCK DIAGRAM FOR ACT2813

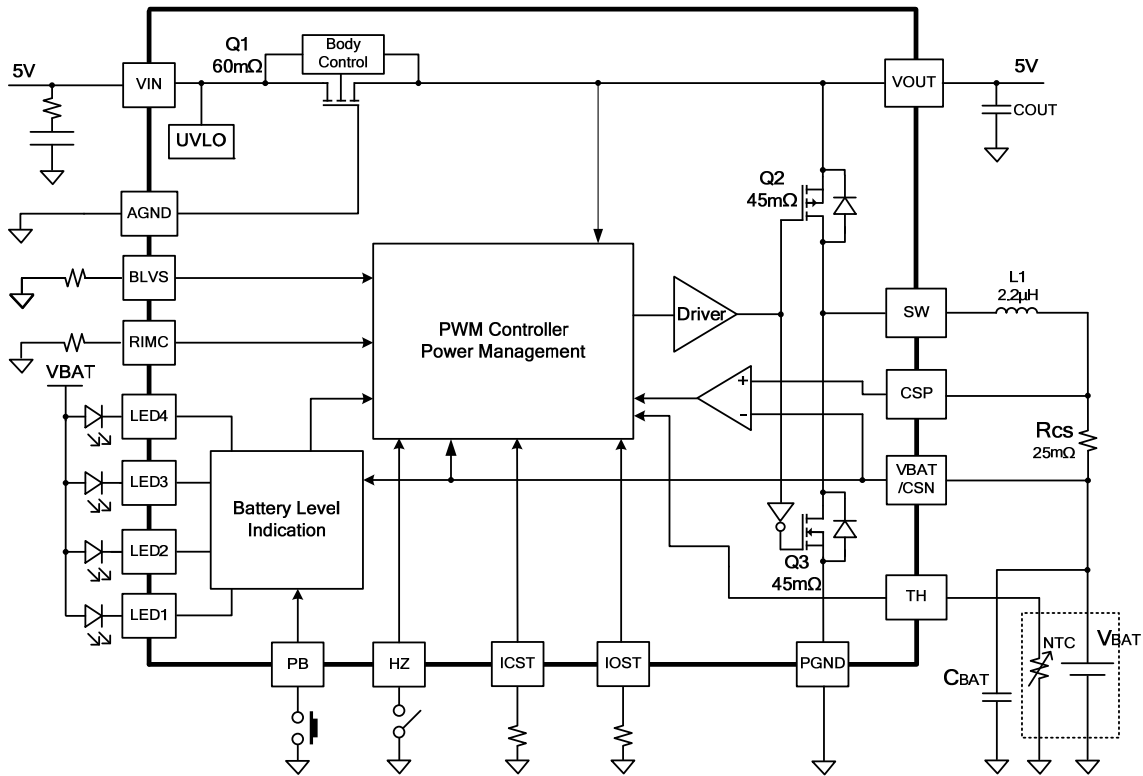

## FUNCTIONAL BLOCK DIAGRAM FOR ACT2813C

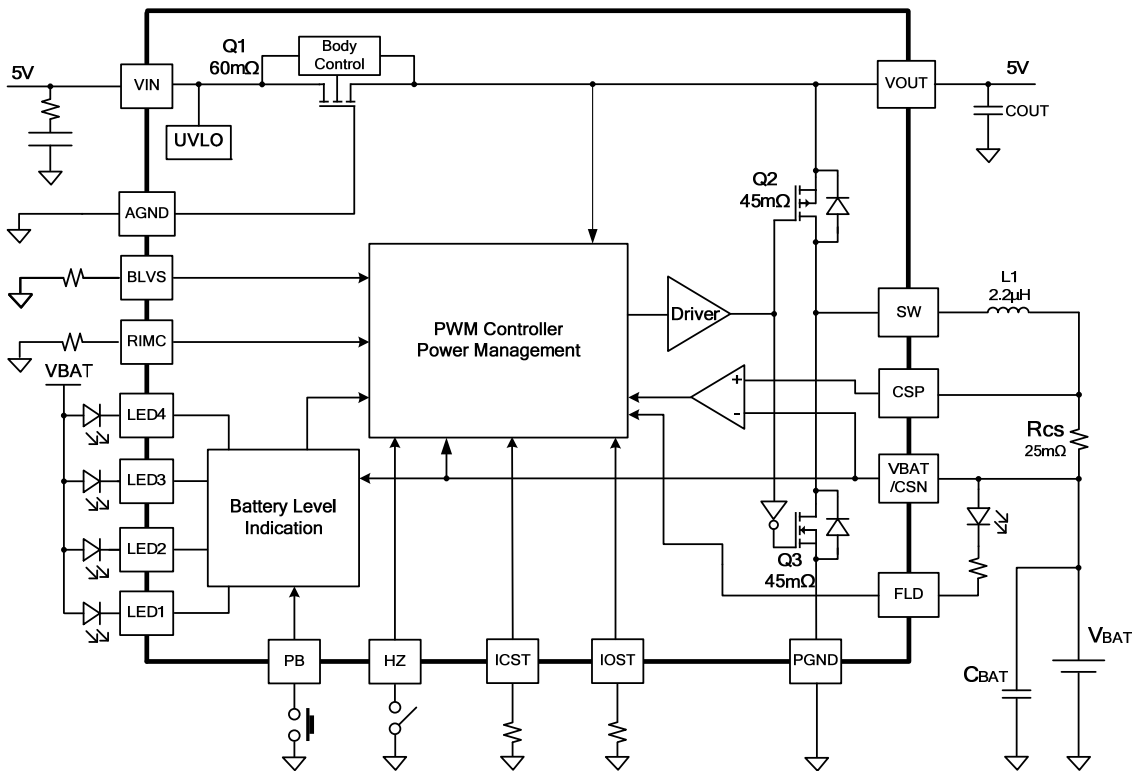



## FUNCTIONAL DESCRIPTION

ACT2813/ACT2813C is a complete battery charging and discharging power management solution for applications of single-cell lithium-based backup battery pack or power bank. There is a power path from input to output. If output voltage drops below 4.25V, the input switch Q1 turns off and restart in 2 seconds.

With the advanced ACT2813/ACT2813C architecture, a synchronous buck/boost converter is connected from VOUT to switching node (SW). With the bidirectional architecture, the converter could be configured as either buck to charge battery or boost to discharge battery. With switching charger and discharger, the higher charge current and higher conversion efficiency are achieved.

### Modes of Operation

ACT2813/ACT2813C has 3 operation modes: charge mode, boost mode and high-impedance (HZ) mode. In charge mode, the input current limit Q1 is enabled and Q2 and Q3 operate as a buck converter to charge battery. In boost mode, Q2 and Q3 operate as boost converter to step battery voltage up to +5V at VOUT, and the current limit switch Q1 is turned off, and the reverse current from VOUT to VIN is blocked. In HZ mode, all the switches are turned off and the drainage current from battery is very low. ACT2813 system operation flow chart as shown in Figure 1 and ACT2813C system operation flow chart as shown in Figure 2.

Any transitions between boost mode and charge mode go through HZ mode by turning off all the

switches Q1-Q3 into HZ mode for 2 seconds before enabling the other mode.

The modes are determined by HZ pin and VIN pin as shown in the table 1. A valid VIN voltage forces ACT2813/ACT2813C into charge mode. Boost mode is enabled if HZ pin is pulled low and VIN is invalid or not present. When HZ=0, if PB is pulled low for more than 30ms, boost converter is enabled. For ACT2813, a running boost is disabled if one of the following conditions is met:

1. Boost converter output current is below light load threshold for 16 seconds.
2. Battery voltage falls below the boost cut-off threshold.
3. After PB is released, if PB is pulled low for more than 1.5 seconds.

Table 1: Mode Selection

| HZ PIN    | 0     | 0      | 1  | 1      |
|-----------|-------|--------|----|--------|
| VIN Valid | 0     | 1      | 0  | 1      |
| Mode      | Boost | Charge | HZ | Charge |

### Flashlight

ACT2813C has an flashlight function. Once PB is pressed for more than 3 seconds, the flashlight is switched on. The driver will deliver up to 50mA current to the flashlight. During flashlight on, if PB is pressed for 3 seconds, flashlight will be switched off.

Figure 1:  
ACT2813 System Operation Flow Chart

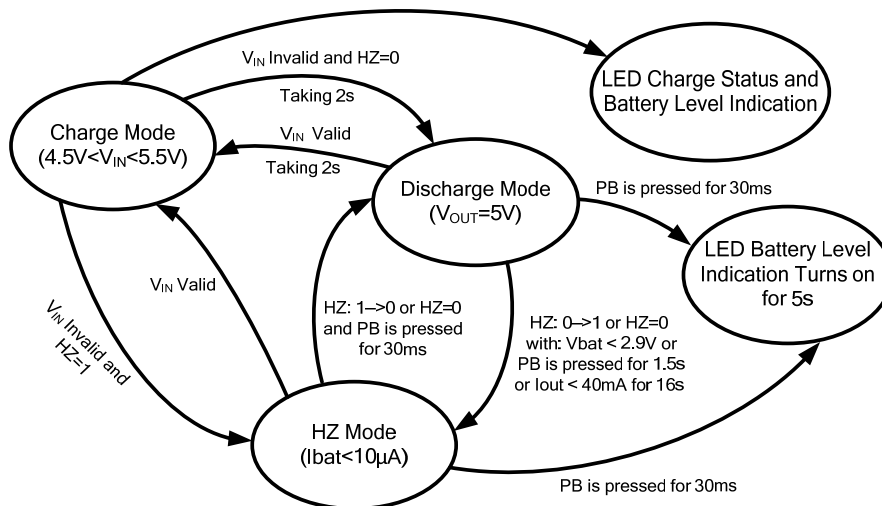

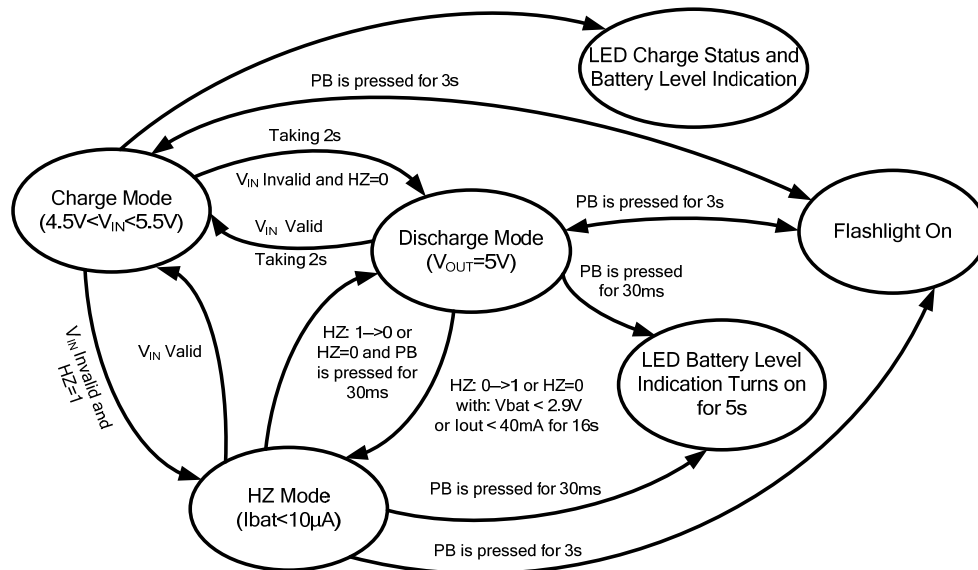
**Figure 2:**
**ACT2813C System Operation Flow Chart**

## Latch-Off

ACT2813/ACT2813C has latch off function. If discharging stops due to battery cut-off, and latch off will be triggered, it would prevent battery from discharging again, latch-off is released when input power is recycled.

## Switching Battery Charger

ACT2813/ACT2813C is configured in charge mode (buck mode) when  $V_{IN}$  is valid. In this mode, the battery is charged with preconditioning, fast charge, top-off and end of charge (EOC). The typical charge management is shown in Figure 3 and Figure 4.

## CC/CV Regulation Loop

There are CC/CV regulation loops built in ACT2813/ACT2813C, which regulates either current or voltage as necessary to ensure fast and safe charging of the battery. In a normal charge cycle, this loop regulates the current to the value set by the external resistor at the ICST pin. Charging continues at this current until the battery cell voltage reaches the termination voltage. At this point the CV loop takes over, and charge current is allowed to decrease as necessary to maintain charging at the termination voltage.

## Precondition Charge

A new charging cycle begins with the precondition state, and operation continues in this state until  $V_{BAT}$  exceeds the precondition threshold voltage. When operating in precondition state, the cell is charged

at a reduced current, 10% of the programmed maximum fast charge constant current. Once  $V_{BAT}$  reaches the precondition threshold voltage the state machine jumps to the fast charge state.

## Fast Charge

If battery voltage is above preconditioning threshold, buck converter charges battery with constant current. In fast charge state, the ACT2813/ACT2813C charges at the current set by the external resistor connected at the ICST pin. During a normal charge cycle fast charge continues in CC mode until  $V_{BAT}$  reaches the charge termination voltage, at which point the ACT2813/ACT2813C charges in top off state.

## Top Off

With the battery voltage approaches the EOC voltage, charge current decreases as charging continues. In the top off state, the cell is charged in constant voltage (CV) mode. During a normal charging cycle charging proceeds until the charge current decreases below the end of charge (EOC) threshold, defined as 15% of fast charge current. When this happens, the state machine terminates the charge cycle and jumps to the EOC state.

## End of Charge

When charges current decreases to 15% of set fast charge current, the buck converter goes into end of charge mode and keep monitoring the battery voltage.

## Recharge

When battery voltage drops by 200mV below the end of charge voltage, the charger is reinitiated with constant current charge.

**Figure 3.**  
**Typical Li+ Charge Profile and ACT2813/ACT2813C Charge States**

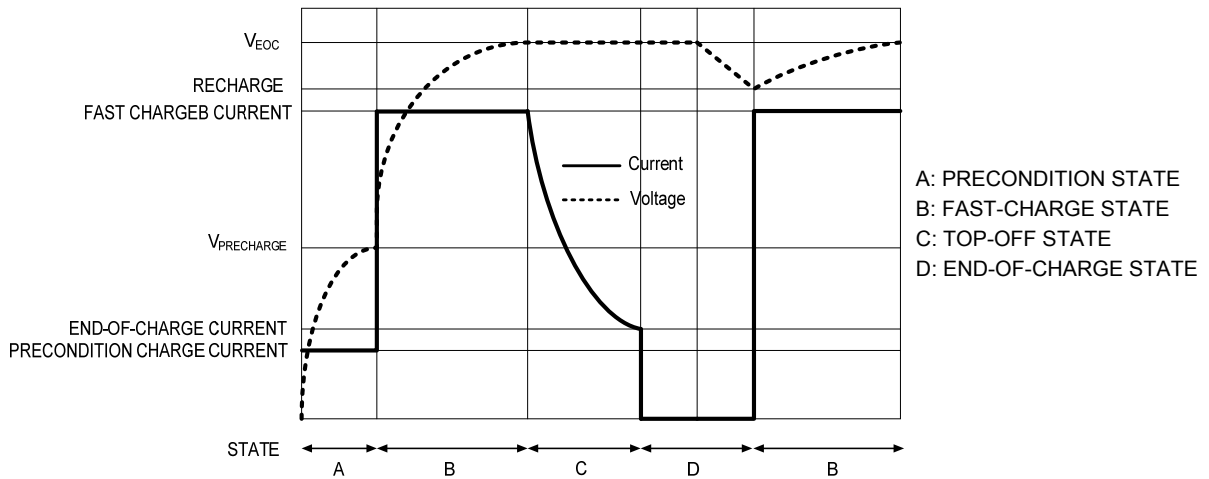

**Figure 4.**  
**Charger State Diagram**

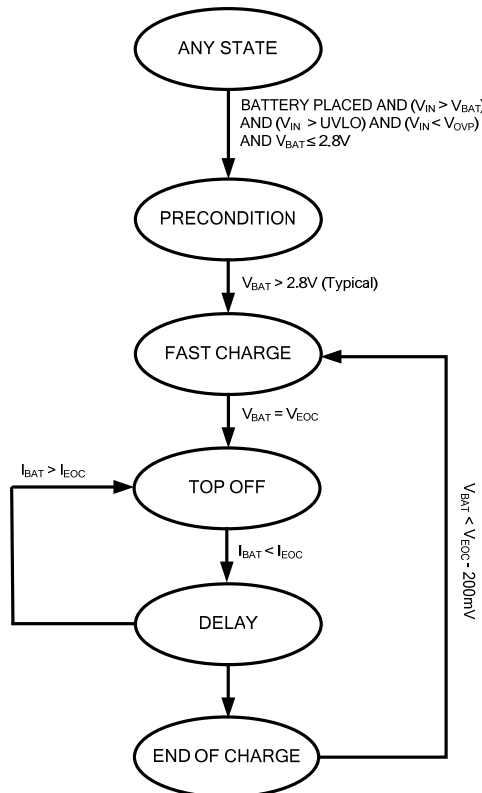

## APPLICATIONS INFORMATION

### Battery level voltage shift (BLVS pin)

LED1-4 voltage thresholds are adjusted from HZ mode during charging and discharging based on the compensated impedance. Those thresholds are programmed by a resistor connected from BLVS pin to AGND as shown in Figure 5. The following equation shows the LED4 voltage threshold:

$$V_{BATLED4}(V) = 3.5(V) + 0.01(mA) \times R_{BLVS}(k\Omega) \quad (1)$$

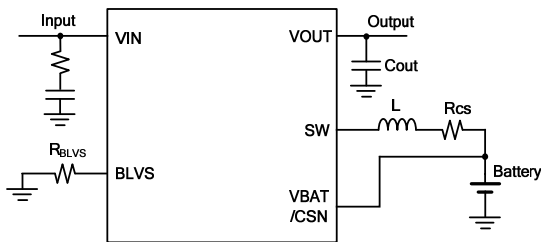

Figure 5. Battery level voltage shift setting circuit

As long as LED4 is set, all the other 3 LED thresholds is fixed as shown in the table 2:

Table 2: 4 LED Voltage Thresholds

| R <sub>BLVS</sub> (ohm) | 50K   | 60K   | 70K   | 80K   |
|-------------------------|-------|-------|-------|-------|
| LED1                    | 3.55V | 3.65V | 3.75V | 3.85V |
| LED2                    | 3.65V | 3.75V | 3.85V | 3.95V |
| LED3                    | 3.80V | 3.90V | 4.00V | 4.10V |
| LED4                    | 4.00V | 4.10V | 4.20V | 4.30V |

### LED Status Indication

4 LEDs ON/OFF and flash show the charge status and the remained capacity level as shown in the

table 3. The LED status is based on battery voltage and operation modes. When battery voltage is low, LED1 is flashing. In charge mode, when a battery is fully charged, flashing stops and all the 4 LEDs are solid on.

### Fast Charge Current

Battery fast charge current is set by a resistor connected from ICST pin to AGND as shown in Figure 6.

The battery fast charge current is estimated as the following equation:

$$I_c(A) = 1.25(A) \times \frac{R_{ICST}(k\Omega)}{R_{cs}(m\Omega)} \quad (2)$$

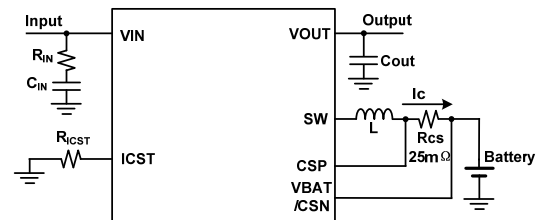

Figure 6. Battery fast charge current setting circuit

Figure 7 gives out different fast charge current with various R<sub>ICST</sub>.

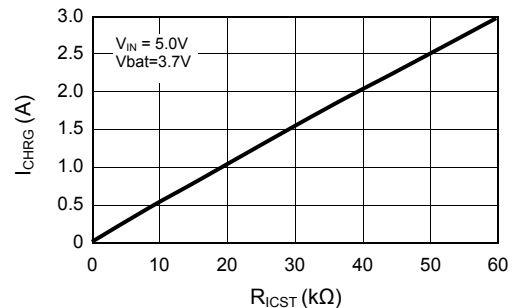

Figure 7. Battery fast charge current setting

Table 3: LED Indication

| LED                                    | Charge Mode |       |       |       | PB time>30ms (Boost or HZ Mode) |      |      |      |
|--|-------------|-------|-------|-------|---------------------------------|------|------|------|
|  | LED1        | LED2  | LED3  | LED4  | LED1                            | LED2 | LED3 | LED4 |
| V <sub>BAT</sub> <2.9V                 | Flash       | Off   | Off   | Off   | Off                             | Off  | Off  | Off  |
| 2.9V≤V <sub>BAT</sub> <LED1            | Flash       | Off   | Off   | Off   | Flash                           | Off  | Off  | Off  |
| LED1≤V <sub>BAT</sub> <LED2            | On          | Flash | Off   | Off   | On                              | Off  | Off  | Off  |
| LED2≤V <sub>BAT</sub> <LED3            | On          | On    | Flash | Off   | On                              | On   | Off  | Off  |
| LED3≤V <sub>BAT</sub> <LED4            | On          | On    | On    | Flash | On                              | On   | On   | Off  |
| V <sub>BAT</sub> ≥LED4                 | On          | On    | On    | Flash | On                              | On   | On   | On   |
| V <sub>BAT</sub> ≥LED4 (End of Charge) | On          | On    | On    | On    | On                              | On   | On   | On   |

## Boost Output Constant Current

Boost output current is set by a resistor connected from IOST pin to AGND as shown in Figure 8. The boost output current is estimated as the following equation:

$$I_{IOST} (A) = \frac{2}{3} (A) \times \frac{R_{IOST} (k\Omega)}{R_{cs} (m\Omega)} \quad (3)$$

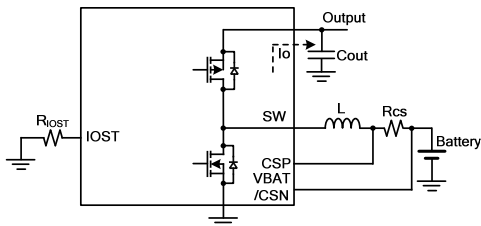

Figure 8. Boost output current setting circuit

Figure 9 gives out boost output current with various R<sub>IOST</sub>.

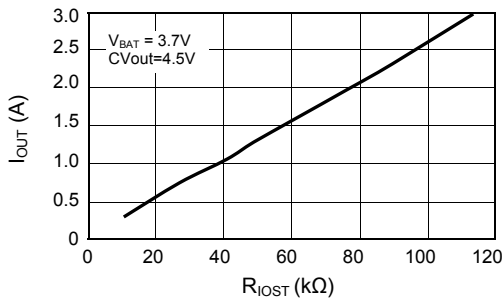

Figure 9. Boost output current setting

The IOST pin voltage is proportional to output current until output current is limited, as shown in Figure 10.

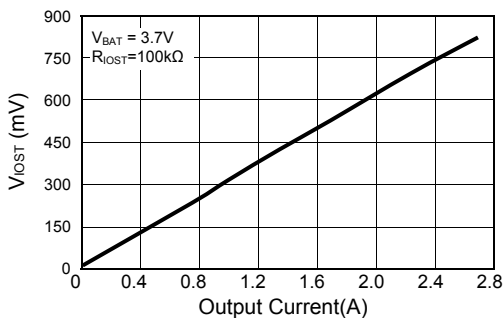

Figure 10. V<sub>IOST</sub> VS. output current

## Battery Impedance Compensation

An external resistor is used to set the impedance from 40mΩ to 500mΩ as shown in Figure 11. R<sub>IMC</sub> is corresponding to battery impedance. Higher R<sub>IMC</sub> gives higher compensation voltage which is positively proportional to battery charge/discharge current.

Select R<sub>IMC</sub> based on battery impedance:

$$R_{IMC} (k\Omega) = \frac{25 \times R (m\Omega)}{R_{cs} (m\Omega)} \quad (4)$$

$$V_{BAT} (V) = BAT (V) - I_{BAT} (A) \times R (m\Omega) \times 10^{-3} \quad (5)$$

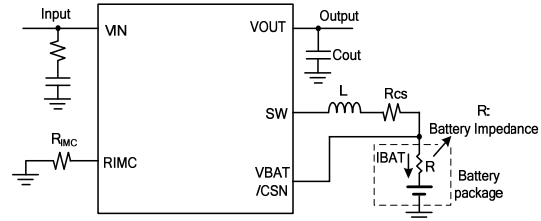

Figure 11. Battery impedance compensation setting circuit

The battery impedance as shown in the table 4 according to the R<sub>IMC</sub> and R<sub>cs</sub>:

Table 4: Battery Impedance

| R <sub>IMC</sub> (KΩ)    |                       | 50  | 100 | 200 |
|--------------------------|-----------------------|-----|-----|-----|
| Battery Impedance R (mΩ) | R <sub>cs</sub> =25mΩ | 50  | 100 | 200 |
|                          | R <sub>cs</sub> =50mΩ | 100 | 200 | 400 |

## Boost Output Plug-in Auto Detection

Figure 12 provides a solution for auto plug-in detection.

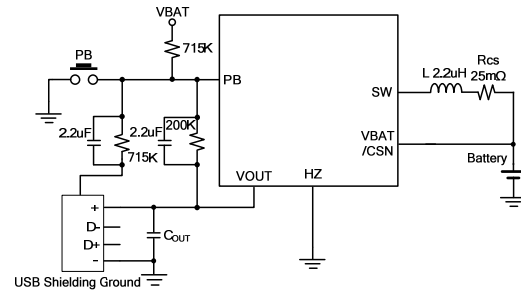

Figure 12. Boost output auto detection circuit

## External Input Over Voltage Protection

Considering the maximum voltage rating at VIN pin, the external OVP circuit as shown in Figure 13 is recommended if input voltage may go higher than 7V. With the enhanced OVP circuit, the design can pass UN38.3.

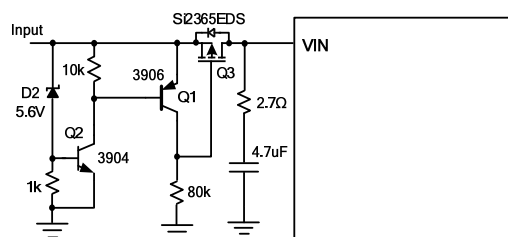

Figure 13. Input over voltage protection

## Input Over Voltage Surge

In the case of pure ceramic input capacitor is chosen, if the input cable is long, stray inductance may cause over voltage spikes as twice as the steady-state voltage when input source is plugged in. Below input circuit is recommended to avoid input voltage surge. R1 resistor is added in series with capacitor C1 to damp the potential LC resonance as shown in Figure 14.

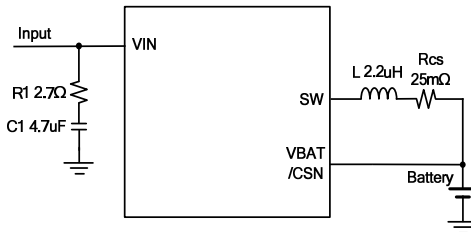

Figure 14. Input over voltage surge protection circuit

## Inductor and Capacitor Selection

ACT2813/ACT2813C supports SMD components. 2.2μH inductor is recommended. Input side, 4.7μF ceramic capacitor in series with 2.7Ω resistor are recommended, on battery side, 22μF ceramic capacitors is recommended while on output side, 22μFx3 ceramic capacitors are recommended.

## Battery Temperature Monitoring

ACT2813 continuously monitors the temperature of the battery pack by sensing the resistance of its thermistor, and suspends charging if the temperature of the battery pack exceeds the safety limits.

In a typical application, the TH pin is connected to the battery pack's thermistor input as shown in Figure 15. The ACT2813 injects a 60μA current out of the TH pin into the thermistor, so that the thermistor resistance is monitored by comparing the voltage at TH to the internal  $V_{THL}$  and  $V_{THH}$  thresholds of 0.3V and 1.5V, respectively. When  $V_{TH} > V_{THH}$  or  $V_{TH} < V_{THL}$  charging and the charge timers are suspended. When  $V_{TH}$  returns to the normal range, charging and the charge timers resume.

The threshold is given by:

$$60\mu A \times R_{NOM} \times k_{HOT} = 0.3V \rightarrow R_{NOM} \times k_{HOT} = 5k\Omega$$

$$60\mu A \times R_{NOM} \times k_{COLD} = 1.5V \rightarrow R_{NOM} \times k_{COLD} = 25k\Omega$$

where  $R_{NOM}$  is the nominal thermistor resistance at room temperature, and  $k_{HOT}$  and  $k_{COLD}$  are the ratios of the thermistor's resistance at the desired hot and cold thresholds, respectively.

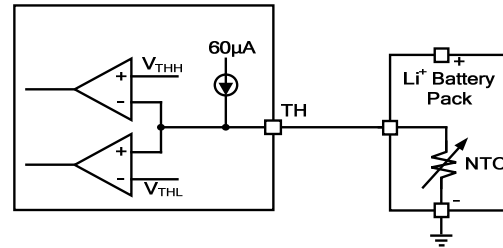

Figure 15. Battery thermal circuit

## PC Board Layout Guidance

When laying out the printed circuit board, the following checklist should be used to ensure proper operation of the IC.

1. Arrange the power components to reduce the AC loop size, VIN pin, Vout pin, SW pin and the schottky diode.
2. Place input decoupling ceramic capacitor C1 and R9 as close to VIN pin as possible. Resistor R9 is added in series with capacitor C1 to damp the potential LC resonance .
3. Use copper plane for power GND for best heat dissipation and noise immunity.
4. Place CSP and CSN capacitor C7 (10nF) close to CSP and CSN pin as possible, use Kevin

5. Sense from sense resistor R1 and R2 to CSP and CSN pins. 22uF decoupling capacitor is added close to VBAT pin.
6. Place the ceramic capacitor C2 and D1 as close to VOUT and PGND as possible, SW goes under the C2 (recommend C2 to use 1206 size). SW pad is a noisy node switching. It should be isolated away from the rest of circuit for good EMI and low noise operation.
6. RC snubber is recommended to add across SW to PGND to reduce EMI noise.

A demo board PCB layout example is shown in the figure 16.

Figure 16.  
PCB Layout

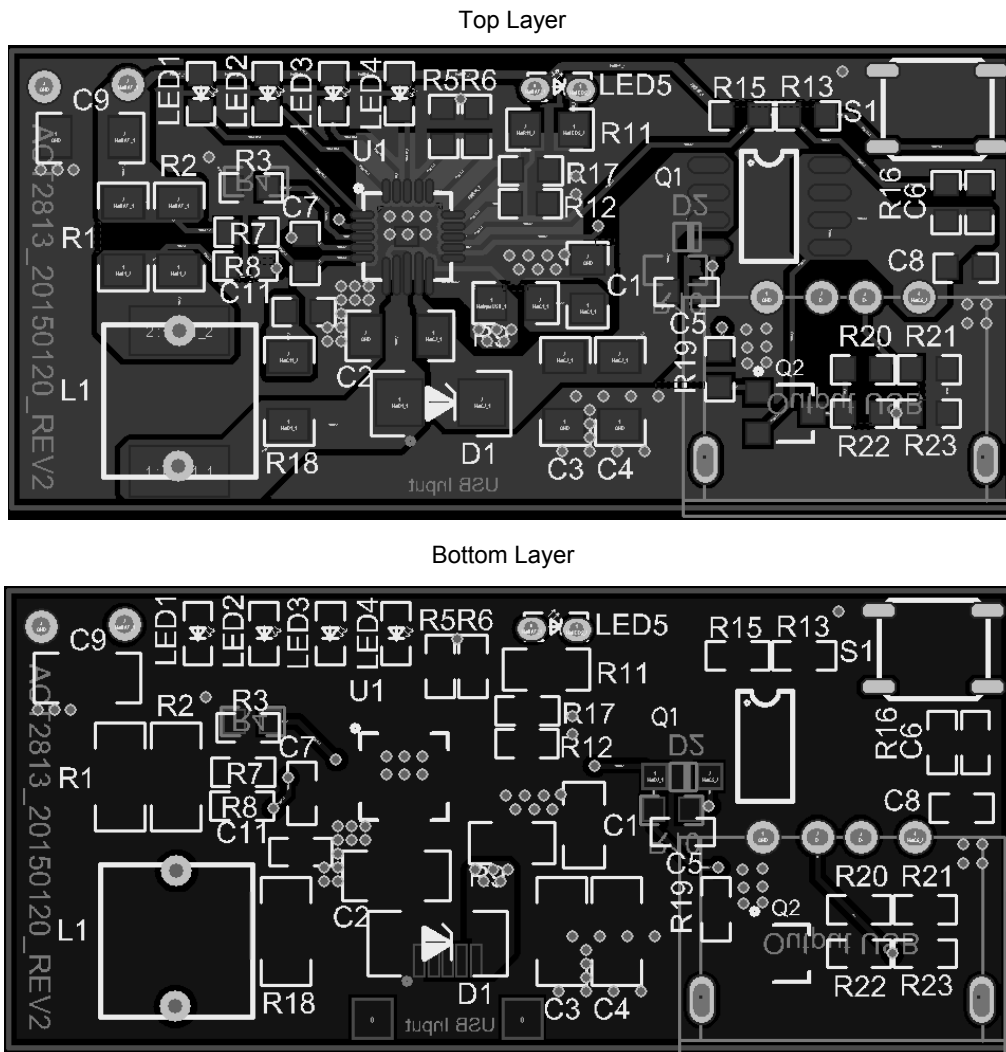



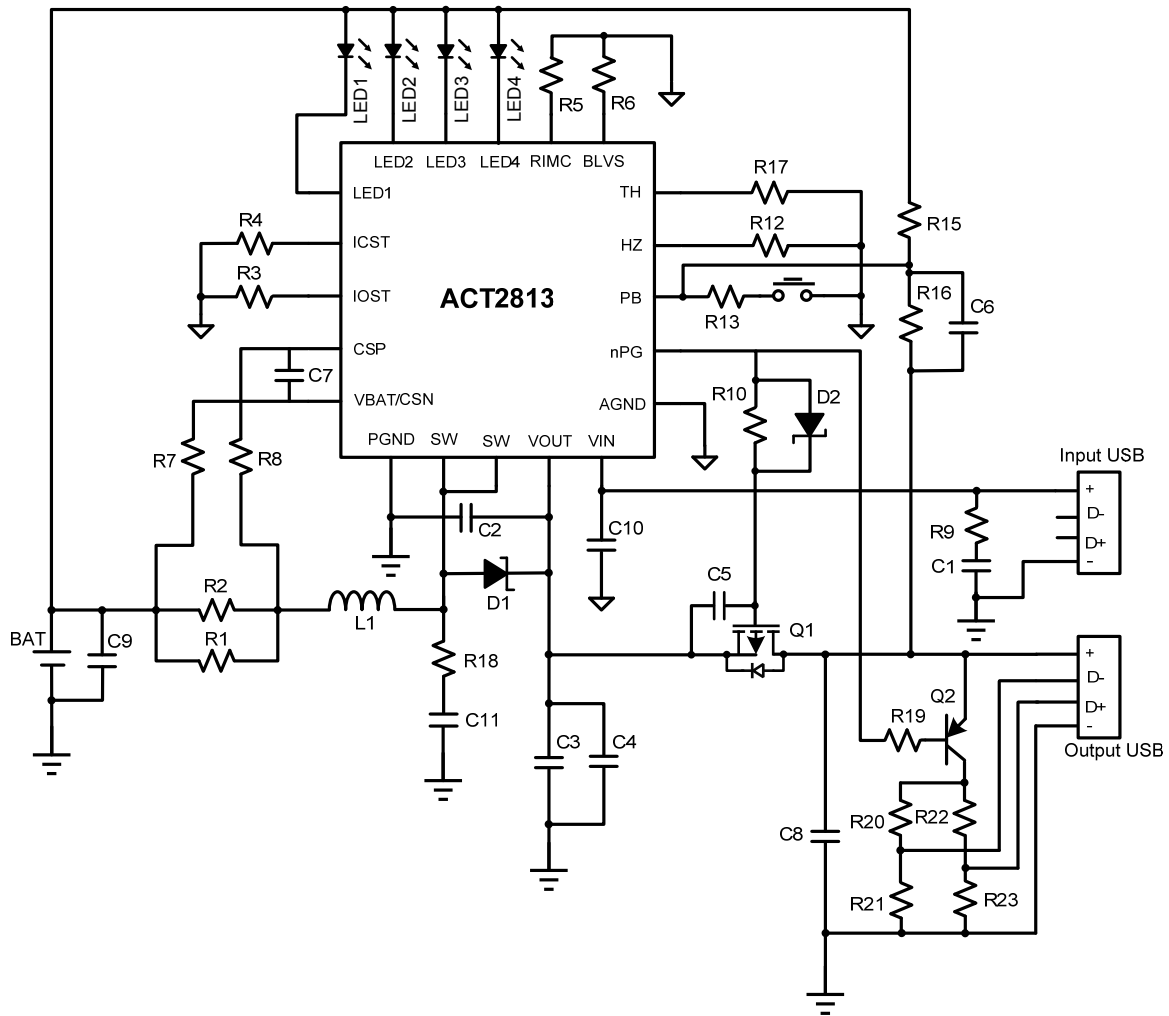

Figure 17. ACT2813 typical application circuit  
(Fast charge current set is 2.4A, boost output constant current set is 2.66A)



**Table 5:**  
**BOM List**

| ITEM | REFERENCE              | DESCRIPTION  | QTY | MANUFACTURER      |
|------|------------------------|--|-----|-------------------|
| 1    | L1                     | Core, 6.5*3*3 Dip, 2.2uH, 6A, Rdson=5mΩ                    | 1   | Sunlord           |
| 2    | Q1                     | AO4503, Rdson=19mΩ at VGS = - 4.5 V                        | 1   | AOS               |
| 3    | Q2                     | MMBT3906   | 1   | Vishay            |
| 4    | D1                     | SBR3U20SA, 20V/3A Schottky<br>MBRA210LT3G, 10V/2A Schottky | 1   | Diodes<br>On-semi |
| 5    | D2                     | 1N4148, Vf=0.7V, 75V Schottky                              | 1   | Vishay            |
| 6    | C1                     | Ceramic capacitor, 4.7uF/10V, X7R, 0805                    | 1   | Murata/TDK        |
| 7    | C2,C3,C4,C9            | Ceramic capacitor, 22uF/10V, X7R, 1206                     | 4   | Murata/TDK        |
| 8    | C5,C6                  | Ceramic capacitor, 2.2uF/10V, X7R, 0603                    | 2   | Murata/TDK        |
| 9    | C7                     | Ceramic capacitor, 10nF/10V, X7R, 0603                     | 1   | Murata/TDK        |
| 10   | C8                     | Ceramic capacitor, 0.1uF/10V, X7R, 0603                    | 1   | Murata/TDK        |
| 11   | C10                    | Ceramic capacitor, 10uF/10V, X7R, 0805                     | 1   | Murata/TDK        |
| 12   | C11                    | Ceramic capacitor, 4.7nF/10V, X7R, 0603                    | 1   | Murata/TDK        |
| 13   | R1,R2                  | Chip Resistor, 50mΩ, 1/4W, 1%, 1206                        | 2   | Murata/TDK        |
| 14   | R3,R10                 | Chip Resistor, 100kΩ, 1/10W, 1%, 0603                      | 2   | Murata/TDK        |
| 15   | R4                     | Chip Resistor, 48kΩ, 1/10W, 1%, 0603                       | 1   | Murata/TDK        |
| 16   | R5                     | Chip Resistor, 68kΩ, 1/10W, 5%, 0603                       | 1   | Murata/TDK        |
| 17   | R6                     | Chip Resistor, 60.4kΩ, 1/10W, 1%, 0603                     | 1   | Murata/TDK        |
| 18   | R7,R8,R12              | Chip Resistor, 0Ω, 1/10W, 1%, 0603                         | 3   | Murata/TDK        |
| 19   | R9                     | Chip Resistor, 2.7Ω, 1/8W, 1%, 0805                        | 1   | Murata/TDK        |
| 20   | R13                    | Chip Resistor, 100Ω, 1/10W, 1%, 0603                       | 1   | Murata/TDK        |
| 21   | R15                    | Chip Resistor, 715kΩ, 1/10W, 5%, 0603                      | 1   | Murata/TDK        |
| 22   | R16,R19                | Chip Resistor, 200kΩ, 1/10W, 5%, 0603                      | 2   | Murata/TDK        |
| 23   | R17                    | Chip Resistor, 10kΩ, 1/10W, 5%, 0603                       | 1   | Murata/TDK        |
| 24   | R18                    | Chip Resistor, 0.47Ω, 1/4W, 1%, 1206                       | 1   | Murata/TDK        |
| 25   | R20,R22                | Chip Resistor, 43.2kΩ, 1/10W, 1%, 0603                     | 2   | Murata/TDK        |
| 26   | R21,R23                | Chip Resistor, 49.9kΩ, 1/10W, 1%, 0603                     | 2   | Murata/TDK        |
| 27   | LED1,LED2<br>LED3,LED4 | LED, 0603, Blue  | 4   | LED Manu          |
| 28   | PB                     | Push Button  | 1   | LED Manu          |
| 29   | USB                    | 10.2*14.6*7mm, 4P, DIP                                     | 1   |                   |
| 30   | Micro-USB              | MICRO USB 5P/F SMT B                                       | 1   |                   |
| 31   | U1                     | IC, ACT2813, FCQFN 4x4-20                                  | 1   | ACT               |

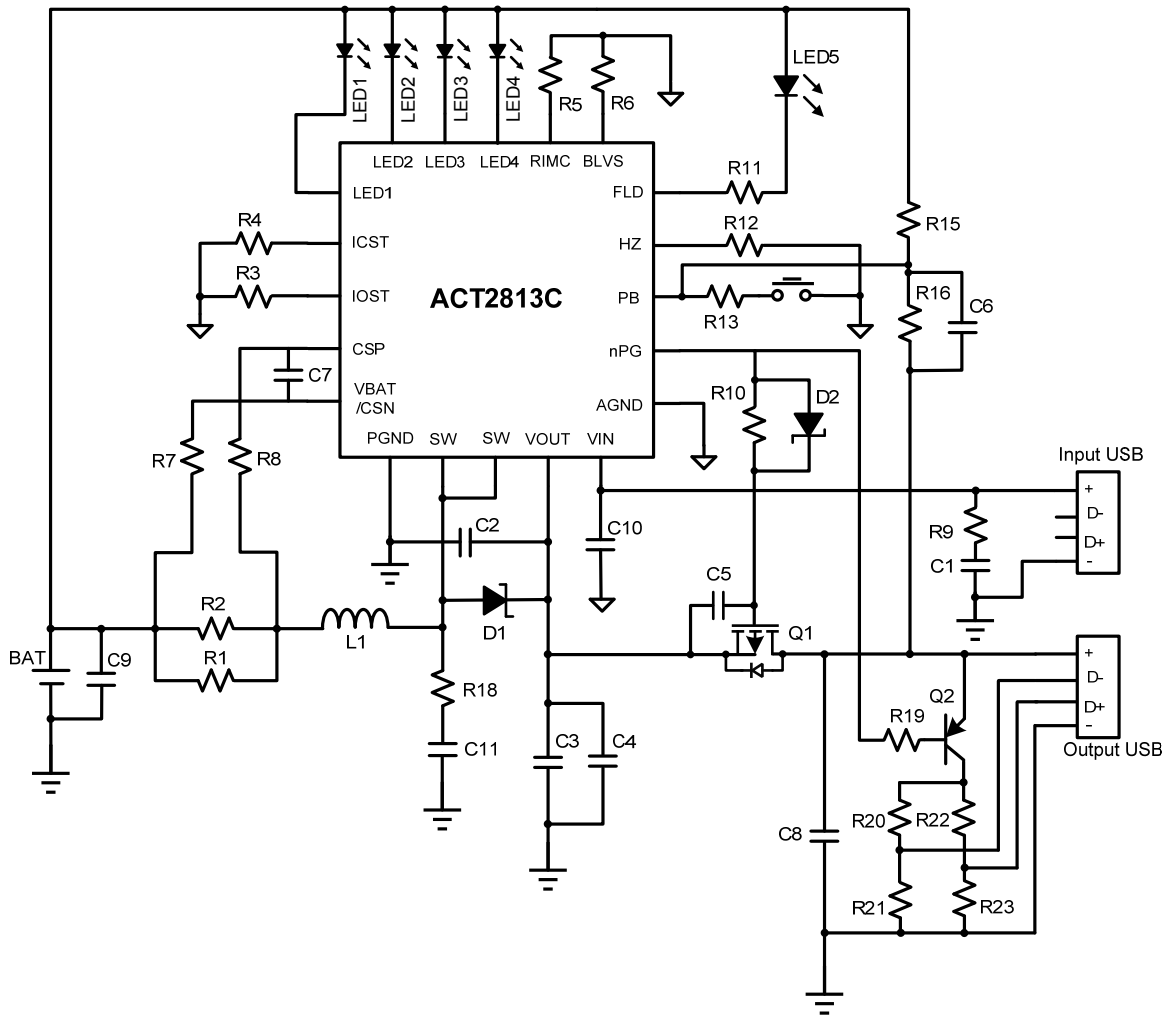

Figure 18. ACT2813C typical application circuit  
(Fast charge current set is 2.4A, boost output constant current set is 2.66A)

**Table 5:**  
**BOM List**

| ITEM | REFERENCE              | DESCRIPTION  | QTY | MANUFACTURER      |
|------|------------------------|--|-----|-------------------|
| 1    | L1                     | Core, 6.5*3*3 Dip, 2.2uH, 6A, Rdson=5mΩ                    | 1   | Sunlord           |
| 2    | Q1                     | AO4503, Rdson=19mΩ at VGS = - 4.5 V                        | 1   | AOS               |
| 3    | Q2                     | MMBT3906   | 1   | Vishay            |
| 4    | D1                     | SBR3U20SA, 20V/3A Schottky<br>MBRA210LT3G, 10V/2A Schottky | 1   | Diodes<br>On-semi |
| 5    | D2                     | 1N4148, Vf=0.7V, 75V Schottky                              | 1   | Vishay            |
| 6    | C1                     | Ceramic capacitor, 4.7uF/10V, X7R, 0805                    | 1   | Murata/TKD        |
| 7    | C2,C3,C4,C9            | Ceramic capacitor, 22uF/10V, X7R, 1206                     | 4   | Murata/TKD        |
| 8    | C5,C6                  | Ceramic capacitor, 2.2uF/10V, X7R, 0603                    | 2   | Murata/TKD        |
| 9    | C7                     | Ceramic capacitor, 10nF/10V, X7R, 0603                     | 1   | Murata/TKD        |
| 10   | C8                     | Ceramic capacitor, 0.1uF/10V, X7R, 0603                    | 1   | Murata/TKD        |
| 11   | C10                    | Ceramic capacitor, 22uF/10V, X7R, 0805                     | 1   | Murata/TKD        |
| 12   | C11                    | Ceramic capacitor, 4.7nF/10V, X7R, 0603                    | 1   | Murata/TKD        |
| 13   | R1,R2                  | Chip Resistor, 50mΩ, 1/4W, 1%, 1206                        | 2   | Murata/TKD        |
| 14   | R3,R10                 | Chip Resistor, 100kΩ, 1/10W, 1%, 0603                      | 2   | Murata/TKD        |
| 15   | R4                     | Chip Resistor, 48kΩ, 1/10W, 1%, 0603                       | 1   | Murata/TKD        |
| 16   | R5                     | Chip Resistor, 68kΩ, 1/10W, 5%, 0603                       | 1   | Murata/TKD        |
| 17   | R6                     | Chip Resistor, 60.4kΩ, 1/10W, 1%, 0603                     | 1   | Murata/TKD        |
| 18   | R7,R8,R12              | Chip Resistor, 0Ω, 1/10W, 1%, 0603                         | 3   | Murata/TKD        |
| 19   | R9                     | Chip Resistor, 2.7Ω, 1/8W, 1%, 0805                        | 1   | Murata/TKD        |
| 20   | R11                    | Chip Resistor, 51Ω, 1/8W, 1%, 0805                         | 1   | Murata/TKD        |
| 21   | R13                    | Chip Resistor, 100Ω, 1/10W, 1%, 0603                       | 1   | Murata/TKD        |
| 22   | R15                    | Chip Resistor, 715kΩ, 1/10W, 5%, 0603                      | 1   | Murata/TKD        |
| 23   | R16,R19                | Chip Resistor, 200kΩ, 1/10W, 5%, 0603                      | 2   | Murata/TKD        |
| 24   | R18                    | Chip Resistor, 0.47Ω, 1/4W, 1%, 1206                       | 1   | Murata/TKD        |
| 25   | R20,R22                | Chip Resistor, 43.2kΩ, 1/10W, 1%, 0603                     | 2   | Murata/TKD        |
| 26   | R21,R23                | Chip Resistor, 49.9kΩ, 1/10W, 1%, 0603                     | 2   | Murata/TKD        |
| 27   | LED1,LED2<br>LED3,LED4 | LED, 0603, Blue  | 4   | LED Manu          |
| 28   | LED5                   | Flashlight   | 1   | LED Manu          |
| 29   | PB                     | Push Button  | 1   |                   |
| 30   | USB                    | 10.2*14.6*7mm, 4P, DIP                                     | 1   |                   |
| 31   | Micro-USB              | MICRO USB 5P/F SMT B                                       | 1   |                   |
| 32   | U1                     | IC, ACT2813C, FCQFN 4x4-20                                 | 1   | ACT               |

## TYPICAL PERFORMANCE CHARACTERISTICS CONT'D

(Schematic as show in Figure 17, Ta = 25°C, unless otherwise specified)

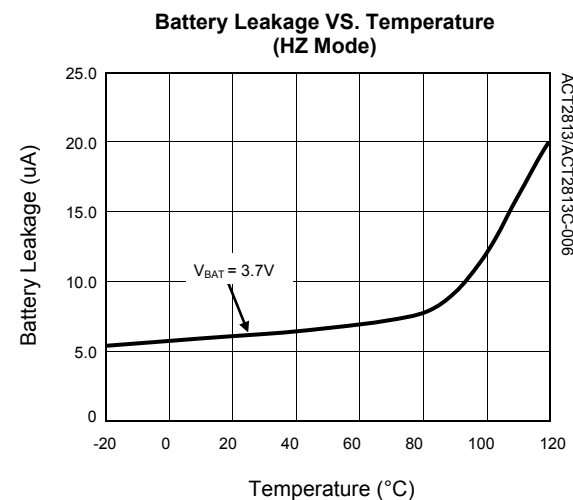
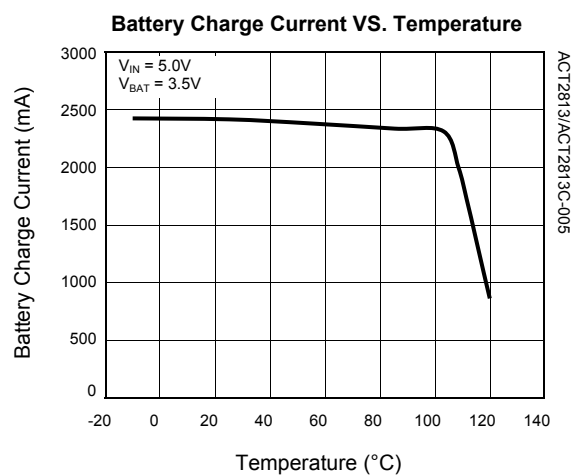
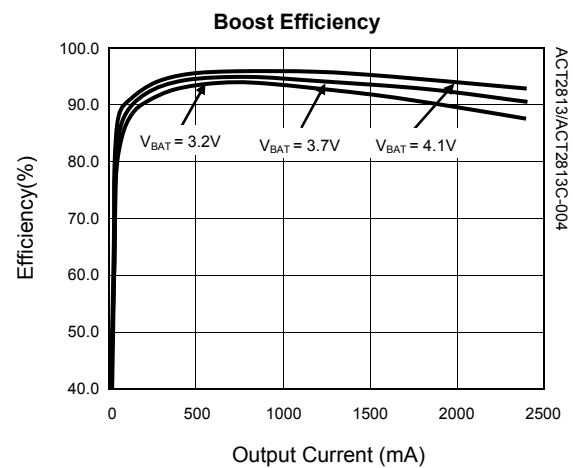
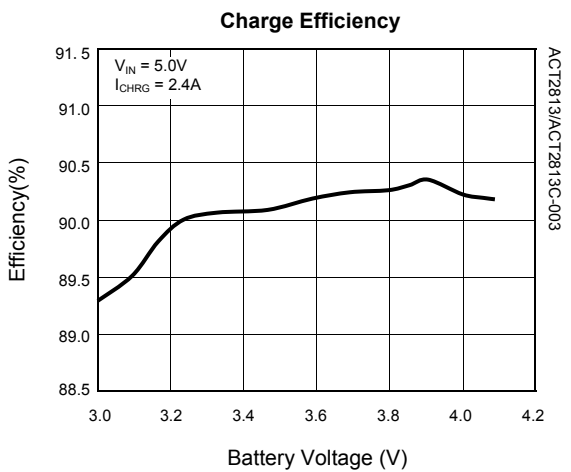
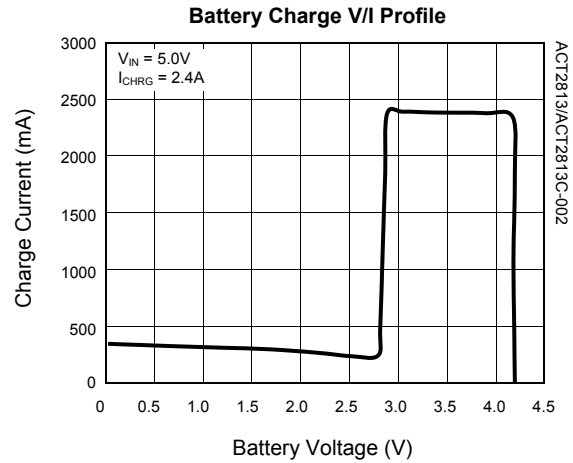
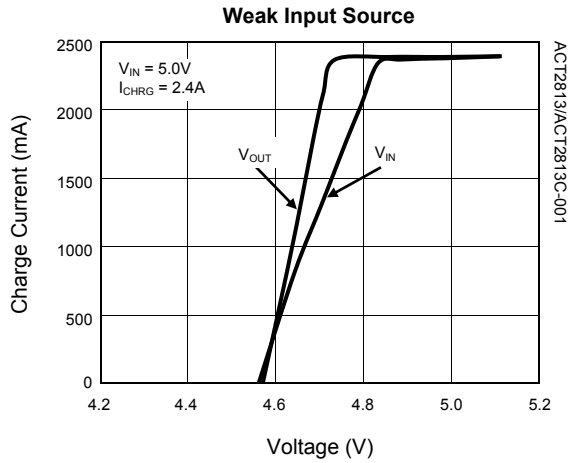

## TYPICAL PERFORMANCE CHARACTERISTICS CONT'D

(Schematic as show in Figure 17, Ta = 25°C, unless otherwise specified)

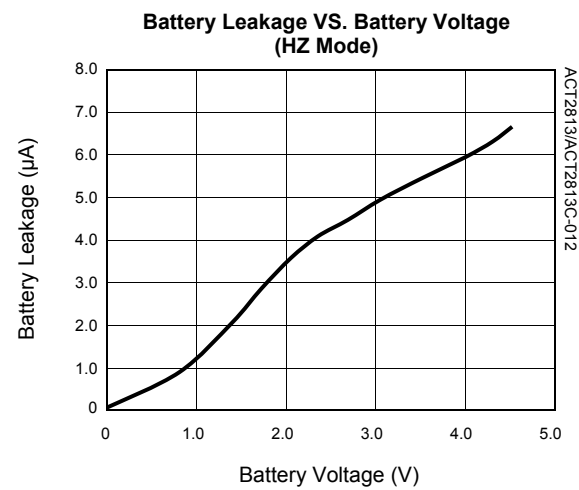
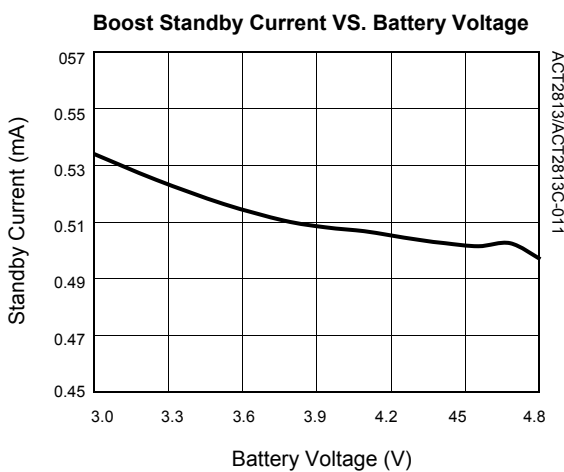
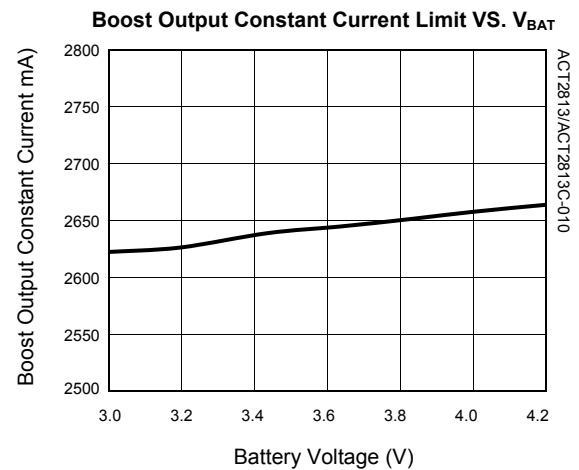
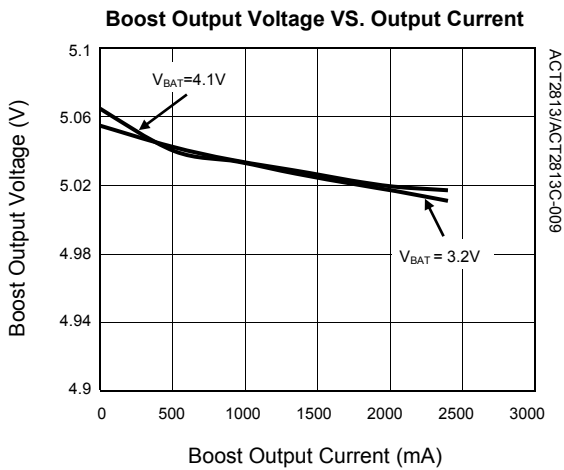
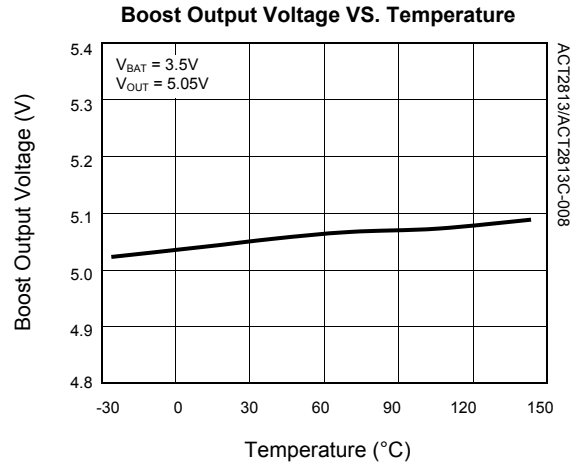
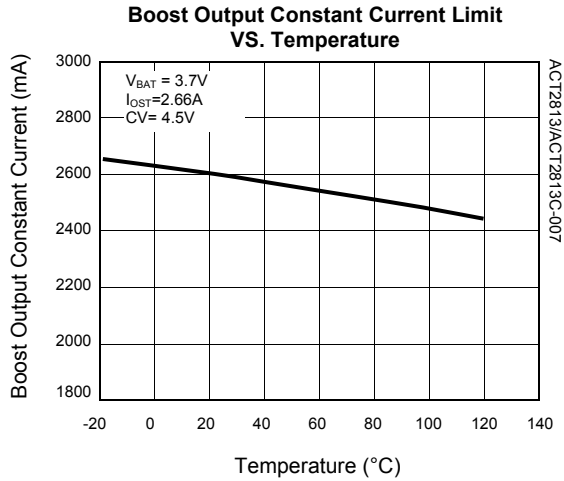

## TYPICAL PERFORMANCE CHARACTERISTICS CONT'D

(Schematic as show in Figure 17, Ta = 25°C, unless otherwise specified)

**Boost Load Transient (80mA-1A-80mA)**

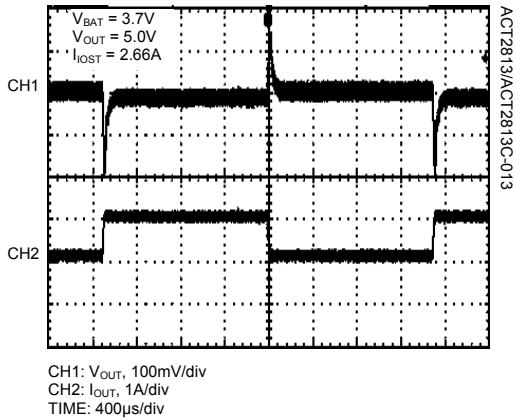

**Boost Load Transient (1A-2.4A-1A)**

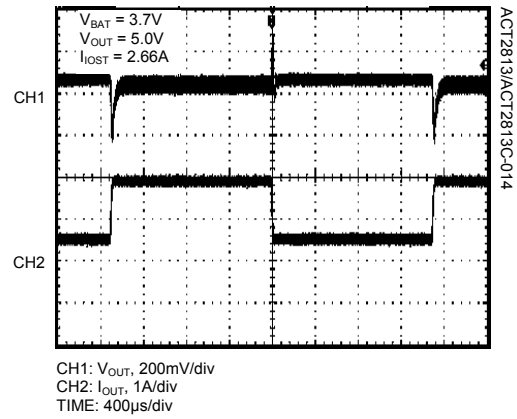

**SW and Output Waveforms in Boost Mode**

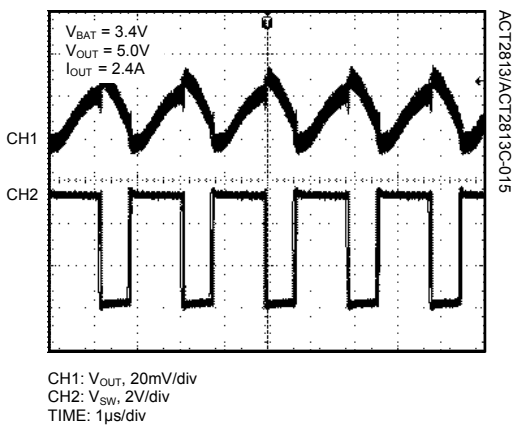

**SW and Output Waveforms in Boost Mode**

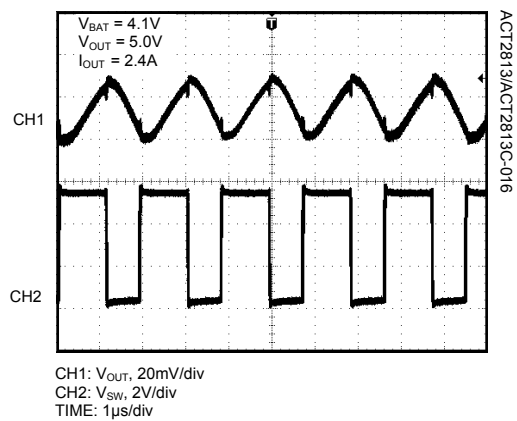

**Transition Between Buck Mode and Boost Mode**

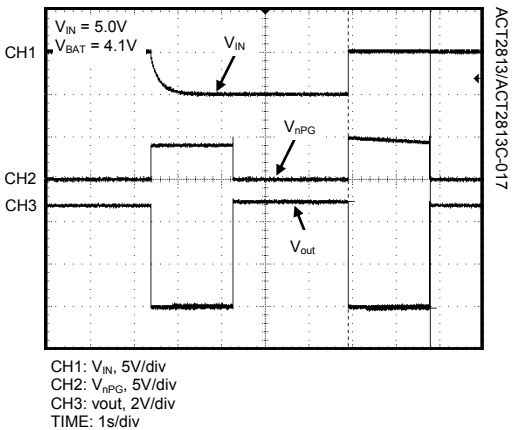

## PACKAGE OUTLINE

### FCQFN 4x4-20 PACKAGE OUTLINE AND DIMENSIONS

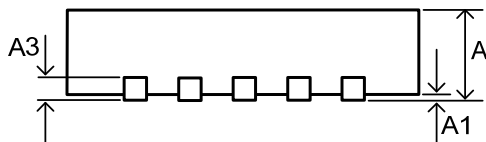
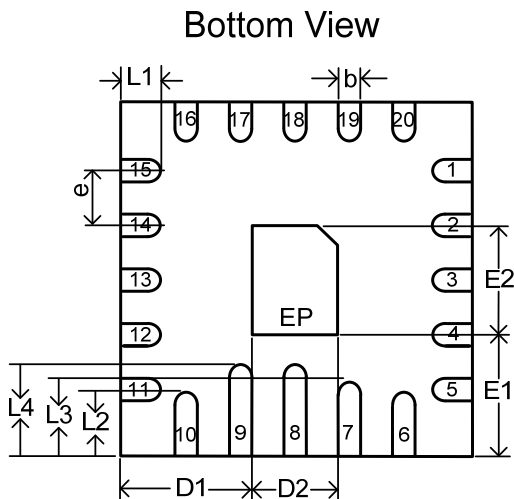
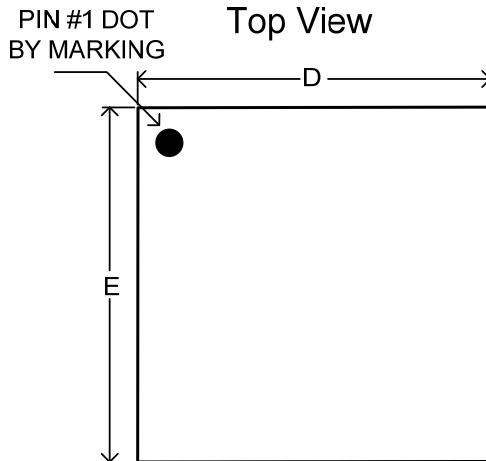

| SYMBOL | DIMENSION IN MILLIMETERS |       | DIMENSION IN INCHES |       |
|--------|--------------------------|-------|---------------------|-------|
|        | MIN                      | MAX   | MIN                 | MAX   |
| A      | 0.800                    | 0.900 | 0.031               | 0.035 |
| A1     | —                        | 0.050 | —                   | 0.002 |
| A3     | 0.203 REF                |       | 0.008 REF           |       |
| b      | 0.200                    | 0.300 | 0.008               | 0.012 |
| D      | 3.950                    | 4.050 | 0.156               | 0.159 |
| D1     | 1.550                    | 1.650 | 0.061               | 0.065 |
| D2     | 0.750                    | 0.850 | 0.030               | 0.033 |
| e      | 0.500 BSC                |       | 0.020 BSC           |       |
| E      | 3.950                    | 4.050 | 0.156               | 0.159 |
| E1     | 1.450                    | 1.550 | 0.057               | 0.061 |
| E2     | 0.950                    | 1.050 | 0.037               | 0.041 |
| L1     | 0.450                    | 0.550 | 0.018               | 0.022 |
| L2     | 0.950                    | 1.050 | 0.037               | 0.041 |
| L3     | 1.050                    | 1.150 | 0.041               | 0.045 |
| L4     | 1.200                    | 1.300 | 0.047               | 0.051 |

Active-Semi, Inc. reserves the right to modify the circuitry or specifications without notice. Users should evaluate each product to make sure that it is suitable for their applications. Active-Semi products are not intended or authorized for use as critical components in life-support devices or systems. Active-Semi, Inc. does not assume any liability arising out of the use of any product or circuit described in this datasheet, nor does it convey any patent license.

Active-Semi and its logo are trademarks of Active-Semi, Inc. For more information on this and other products, contact [sales@active-semi.com](mailto:sales@active-semi.com) or visit <http://www.active-semi.com>.

 is a registered trademark of Active-Semi.