

LOC		DIST		REVISIONS			
P	LTR	DESCRIPTION	DATE	DWN	APVD	SS	GS
A		REVISED PER 063B-0095-05	4/8/05	SS	GS		

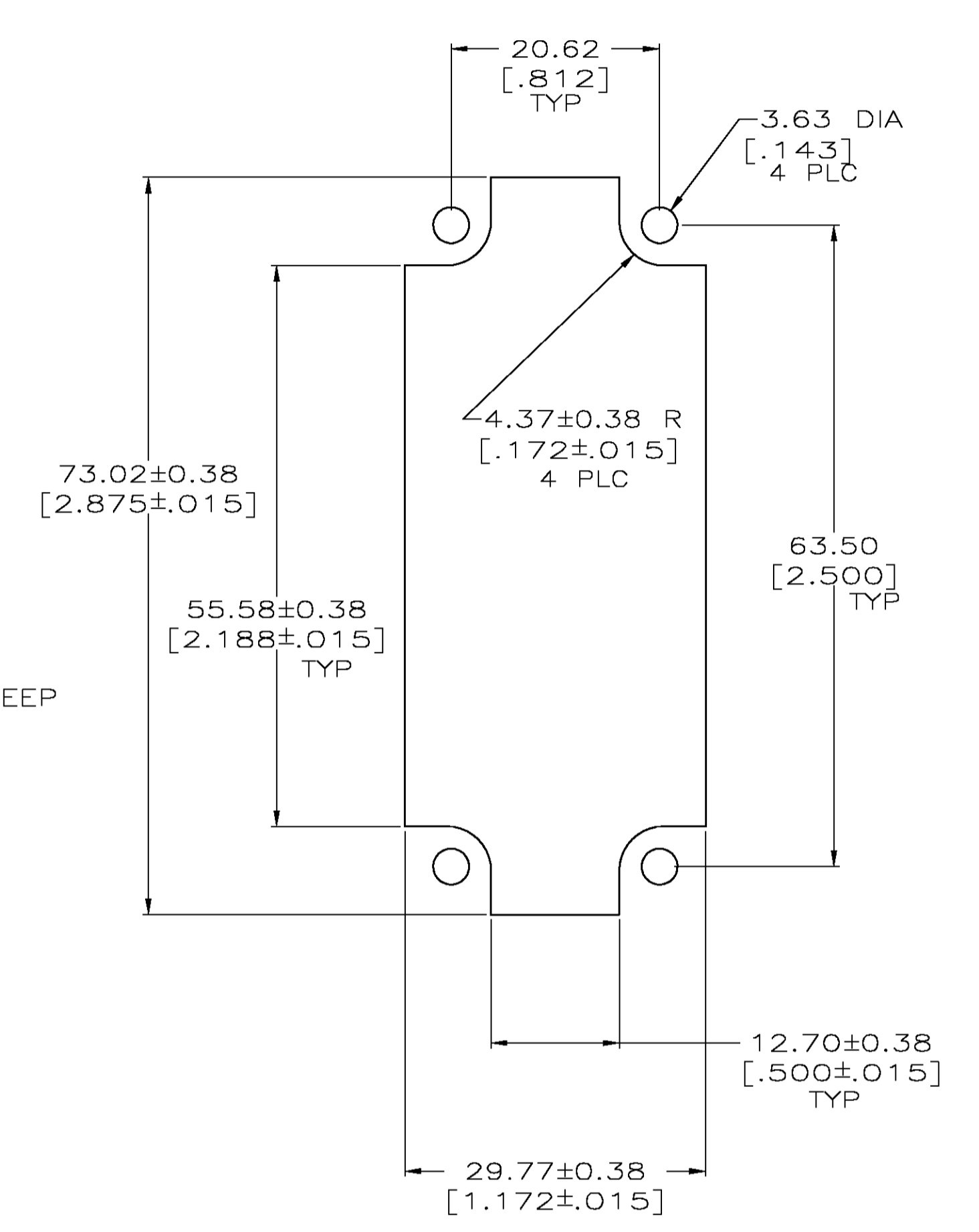

RECOMMENDED PANEL CUTOUT

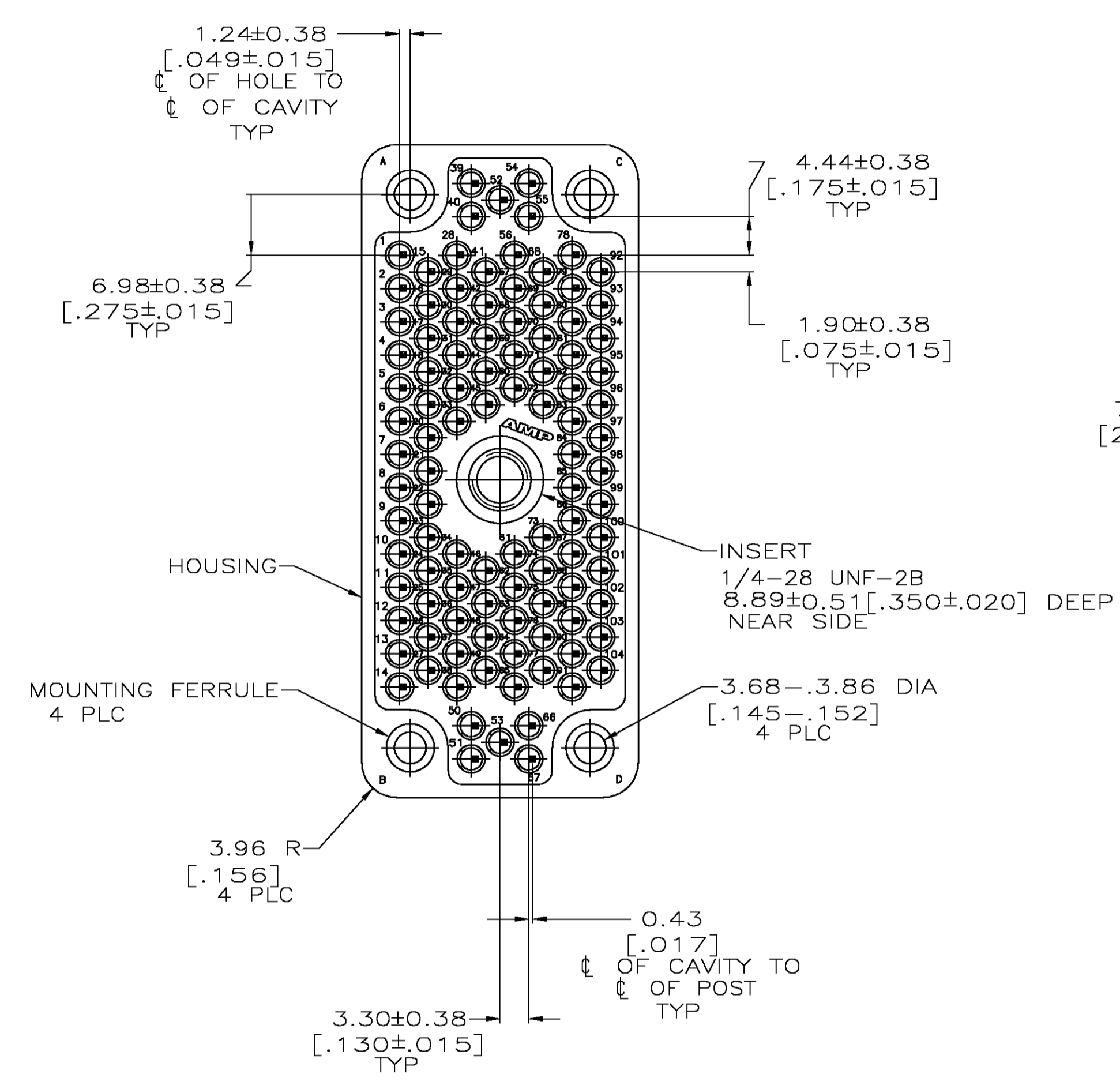
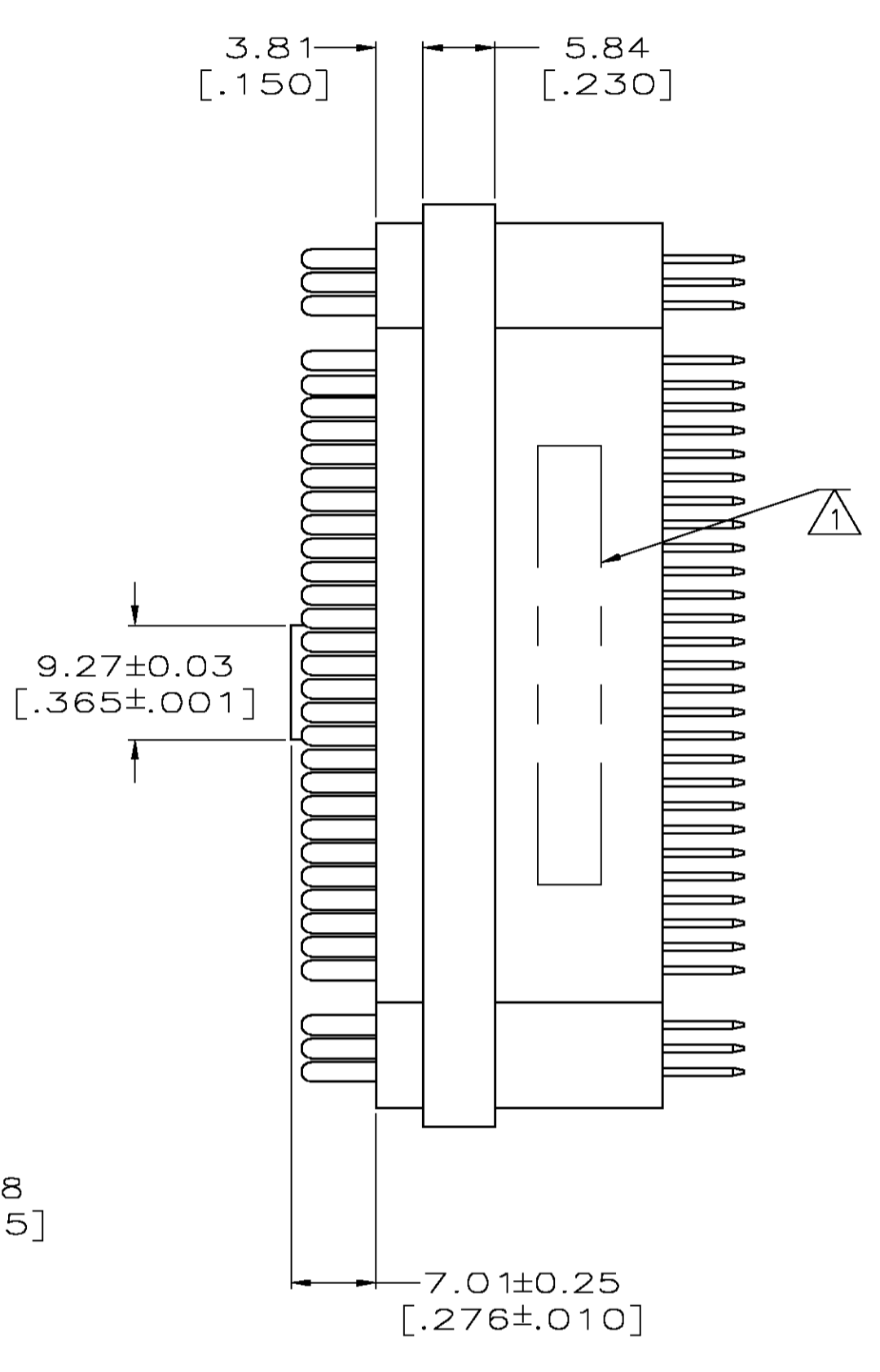
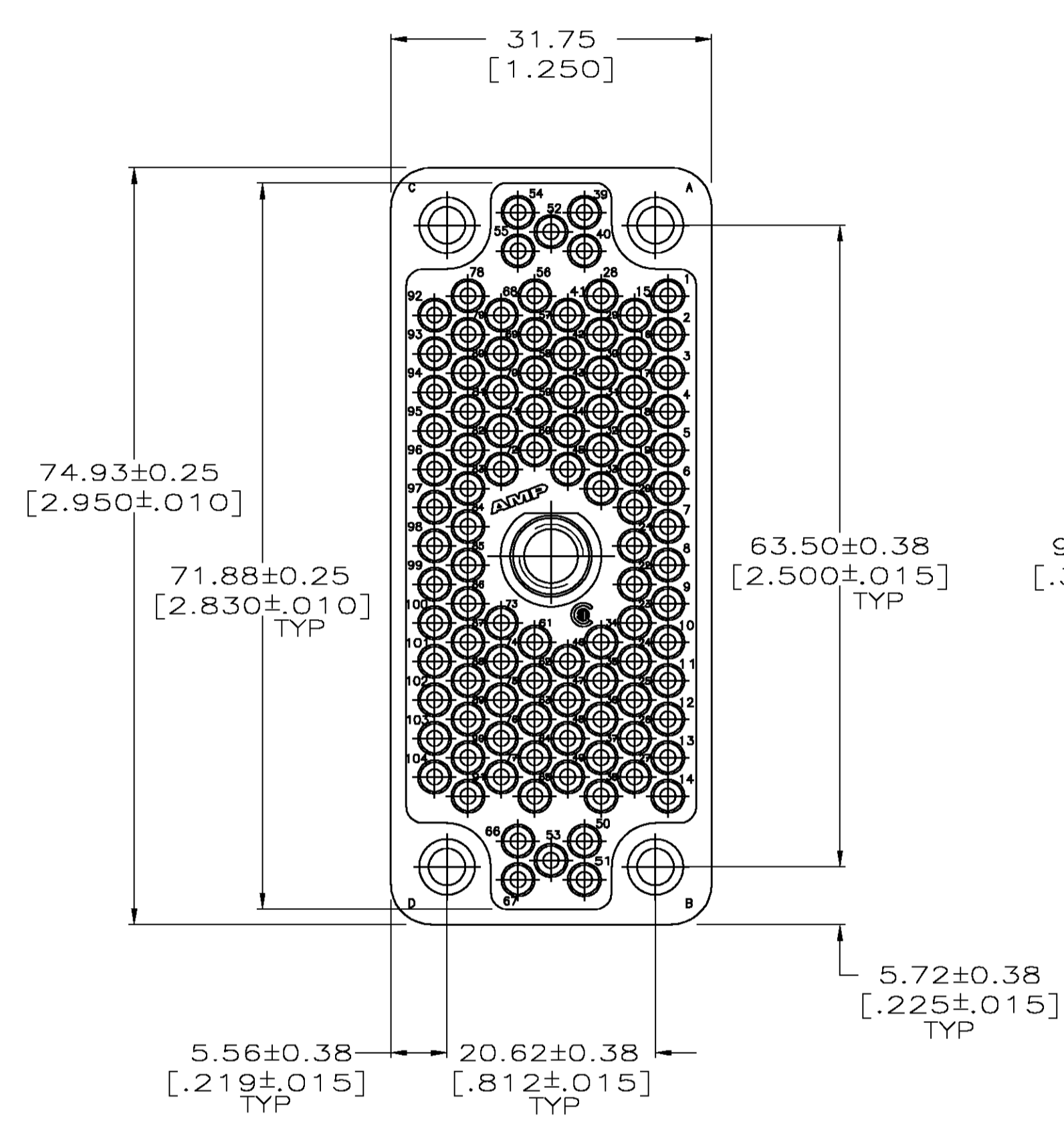
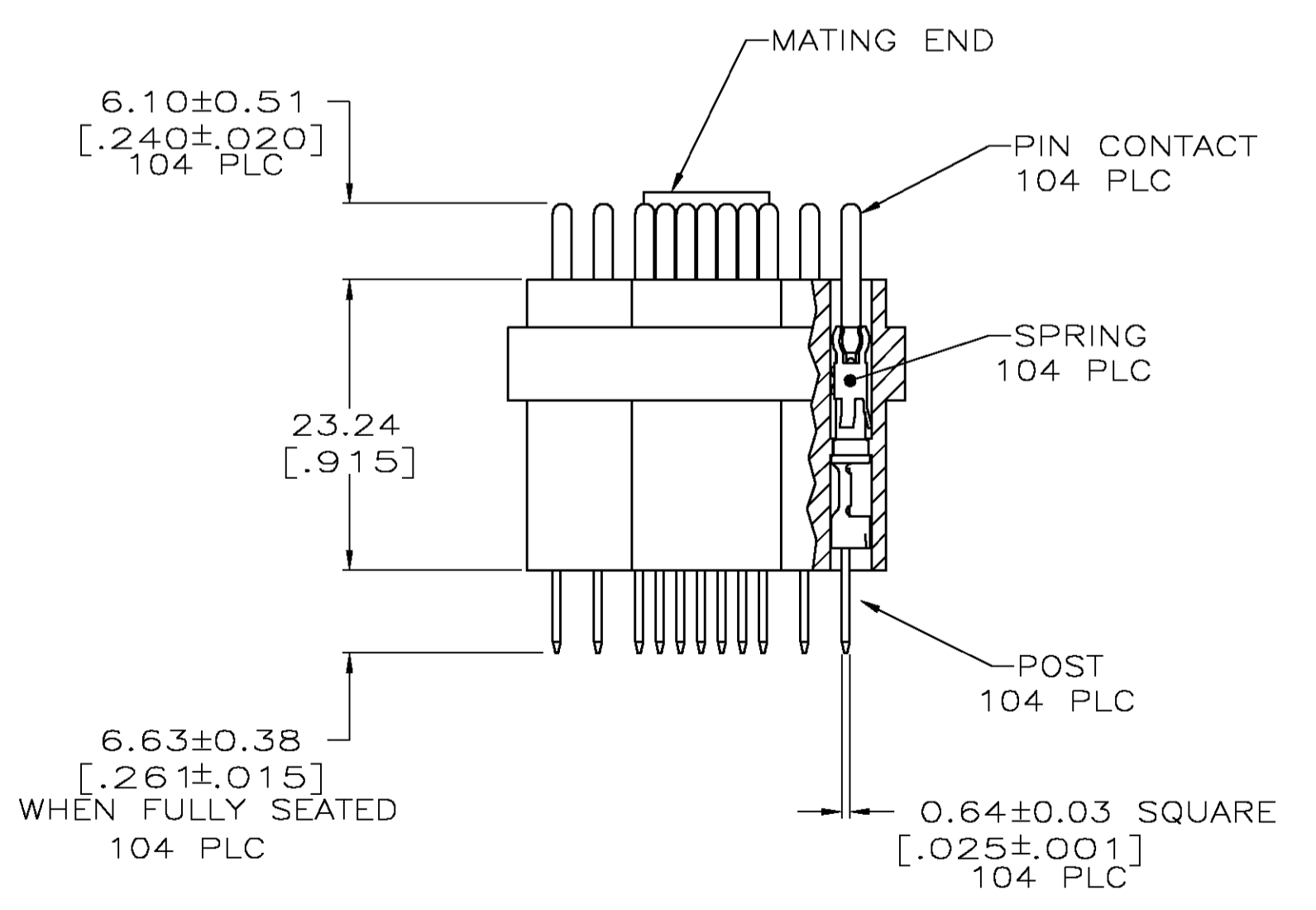

- ⚠ THIS AREA MARKED WITH AMP, 213763-1, AND DATE CODE ON EITHER SIDE.
- 2. POSTS ARE SEMI-AUTOMATICALLY WIREABLE WITH 24 MAX AWG WIRE.
- ⚠ HOUSING: DIALYL PHTHALATE PER MIL-M-14-F TYPE SDG-F, BLUE; INSERT, MOUNTING FERRULES AND SPRINGS: STAINLESS STEEL; POSTS AND PIN CONTACTS: BRASS.
- ⚠ POSTS: 25.4um[.000100] MIN TIN-LEAD OVER 2.54um[.000100] MIN COPPER. PIN CONTACTS: 0.76um[.000030] MIN GOLD FOR A LENGTH OF 6.35[.250] FROM MATING END, GOLD FLASH ON THE REMAINDER, BOTH OVER 1.27um[.000050] MIN NICKEL.
- ⚠ GOLD PLATE PER MIL-G-45204, NICKEL PLATE PER QQ-N-290, TIN-LEAD AND TIN PLATE PER MIL-T-10727.
- ⚠ POSTS: 25.4um[.000100] MIN TIN OVER 2.54um[.000100] MIN COPPER. PIN CONTACTS: 0.76um[.000030] MIN GOLD FOR A LENGTH OF 6.35[.250] FROM MATING END, GOLD FLASH ON THE REMAINDER, BOTH OVER 1.27um[.000050] MIN NICKEL.

⚠	213763-2
⚠	213763-1
FINISH	PART NUMBER

THIS DRAWING IS A CONTROLLED DOCUMENT.		DWN J. McCLINTON 9-30-92	Tyco Electronics Corporation Harrisburg, Pa 17105-3608	
DIMENSIONS: mm [INCHES]		G/K R STONE 10-1-92	NAME PLUG ASSEMBLY, 104 POSN. W/CENTER INSERT, POSTED, M SERIES	
TOLERANCES UNLESS OTHERWISE SPECIFIED:		APVD -	PRODUCT SPEC 108-10001	
0 PLC ± -		APPLICATION SPEC		
1 PLC ± ± 0.13[.005]		SIZE A1		
2 PLC ± ± -		CAGE CODE 00779		
3 PLC ± ± -		DRAWING NO 213763		
4 PLC ± ± -		RESTRICTED TO		
ANGLES ± ± -		WEIGHT		
FINISH		CUSTOMER DRAWING		
		SCALE 2:1 SHEET 1 OF 1 REV A		