

4

3

2

1

THIS DRAWING IS UNPUBLISHED. RELEASED FOR PUBLICATION

© COPYRIGHT BY TYCO ELECTRONICS CORPORATION. ALL RIGHTS RESERVED.

LOC	DIST	REVISIONS					
ES	00	P	LTR	DESCRIPTION	DATE	DWN	APVD
		E		REVISED ECR-10-010197	17JUN11	T.Q	S.Y

AS SHOWN : 1612257-7

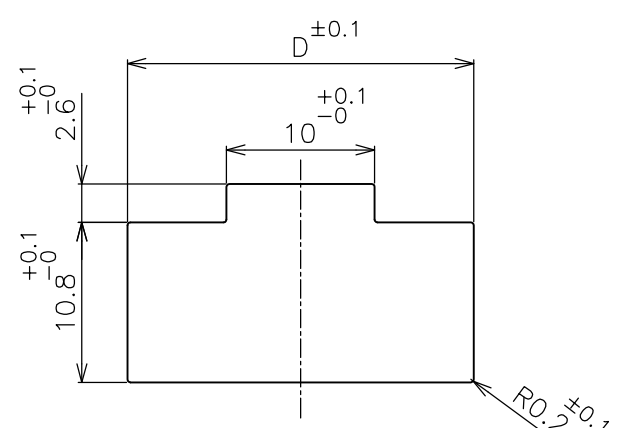
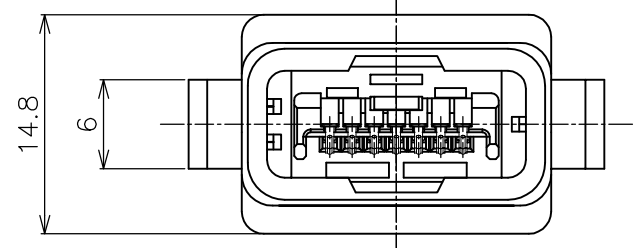
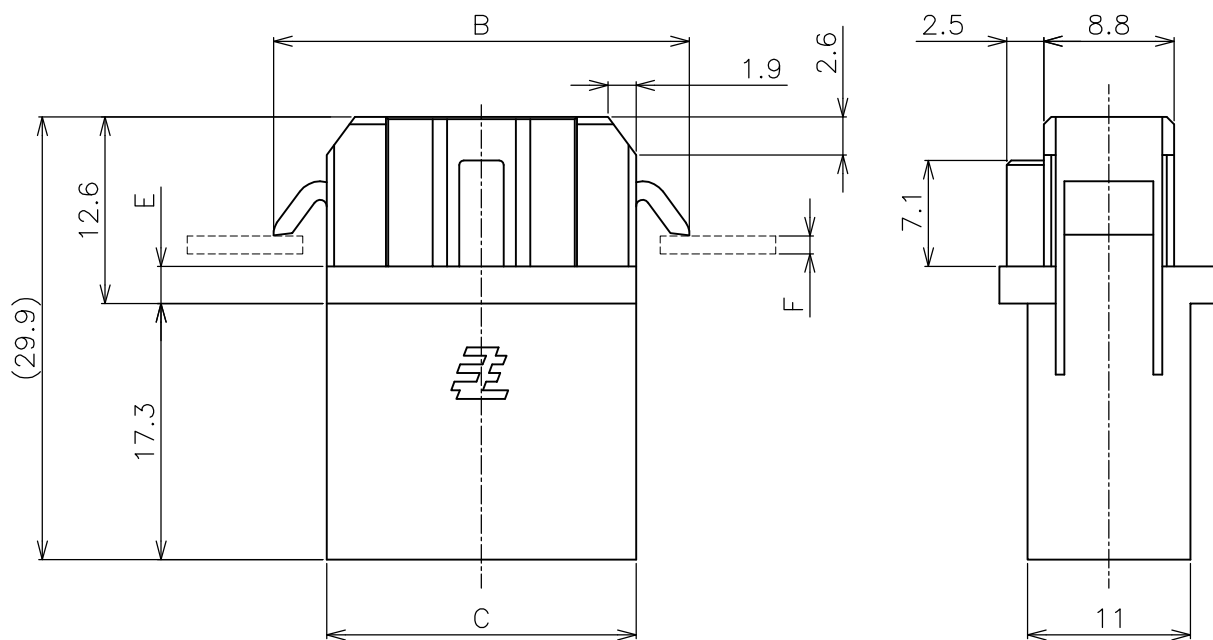
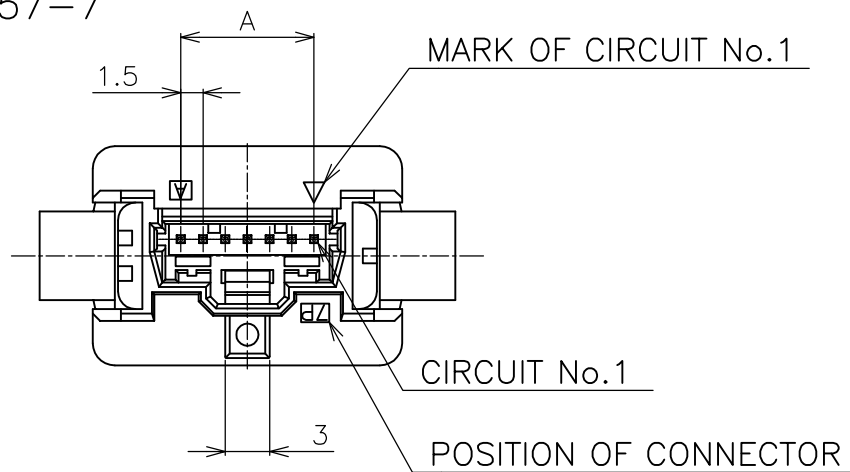

PANEL CUTOUT DIMENSION

- NOTES:
- USE WITH MINI CT MT TYPE P/N : X-353293-X (ASSY)
CRIMP TYPE P/N : 353907-1 (CONTACT)
353907-1(L/P) (CONTACT)
X-353908-X (HOUSING)
 - MATERIAL HOUSING :PBT G.F. UL94 V-0, COLOR: BLACK
CONTACT :COPPER ALLOY
 - FINISH CONTACT : NICKEL UNDER PLATED ALL OVER
CONTACT AREA : GOLD PLATED
POST AREA : Sn 100% PLATED
 - THE PANEL SHOULD BE PUNCHED SO THAT THE HOUSING ENTERS THE PANEL IN THE SAME DIRECTION AS PUNCH.
 - FLOATING DIMENSION : 0.5 MAX (INCLUDE THE AMOUNT OF AXIAL GAPS)
 - DIMENSION BETWEEN PANELS MUST BE SET 21.8-22.8mm. (INCLUDE THE CLEARANCE BETWEEN CONNECTOR AND PANEL)
 - GENERAL TOLERANCE
10>:±0.2
30> >10:±0.25
100> >30:±0.3
ANGLES: ±3°
 - SEQUENTIAL CIRCUIT NO. IS REFERRED CUSTOMER DRAWING : 1612256.

1-1612256-4		1.0 ±0.1		33.9	31.4	38.6	19.5	14	2-1612257-4	
1-1612256-4				33.9	31.4	38.6	19.5	14	1-1612257-4	
1-1612256-2	21.8 △	2.0 ±0.1	2.5	30.9	28.4	35.6	16.5	12	1-1612257-2	
1-1612256-0				27.9	25.4	32.6	13.5	10	1-1612257-0	
1612256-7				23.4	20.9	28.1	9.0	7	1612257-7	
COUNTER MATING CONNECTOR P/N	G	F	E	D	C	B	A	POS.	P/N	
	DIMENSION BETWEEN PANELS		APPLIED PANEL THICKNESS		DIMENSIONS					

THIS DRAWING IS A CONTROLLED DOCUMENT.

DWN	H.HOSHINO	05AUG02	 TE Connectivity			
CHK	T.KUSUHARA	05AUG02				
APVD	I.ENOMOTO	05AUG02				
PRODUCT SPEC	108-5836					
APPLICATION SPEC			NAME			
			RECEPTACLE ASSEMBLY MINI CT DC DRAWER SNAP-FIT SINGLE ROW			
MATERIAL	FINISH	WEIGHT	SIZE	CAGE CODE	DRAWING NO	RESTRICTED TO
			A3	00779	C-1612257	-
CUSTOMER DRAWING			SCALE	SHEET	REV	
			2:1	1 OF 2	E	

4

3

2

1

THIS DRAWING IS UNPUBLISHED.

RELEASED FOR PUBLICATION

LOC

DIST

REVISIONS

© COPYRIGHT

BY TYCO ELECTRONICS CORPORATION.

ALL RIGHTS RESERVED.

ES

00

P

LTR

DESCRIPTION

DATE

DWN

APVD

SEE SHEET 1

-

-

-

AS SHOWN : 1612257-7

SEQUENTIAL

SIGNAL

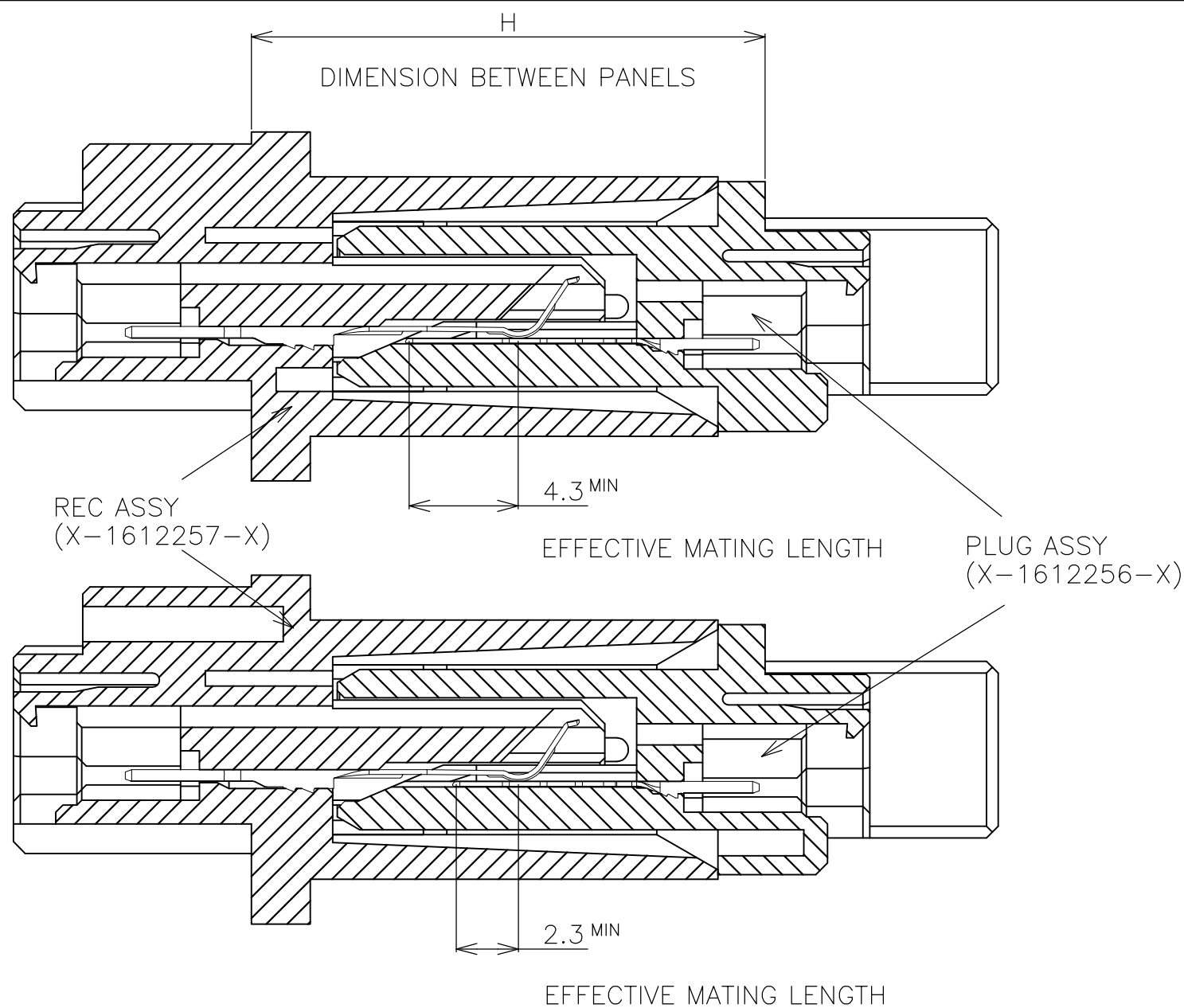

CROSS SECTION

THIS DRAWING IS A CONTROLLED DOCUMENT.

DWN

CHK

APVD

PRODUCT SPEC

APPLICATION SPEC

WEIGHT

CUSTOMER DRAWING



TE Connectivity

NAME

RECEPTACLE ASSEMBLY
MINI CT DC DRAWER SNAP-FIT
SINGLE ROW

SIZE

CAGE CODE

DRAWING NO

RESTRICTED TO

A3

00779

C-1612257

-

SCALE 4:1

SHEET 2 OF 2

REV E

DIMENSIONS:
MM

TOLERANCES UNLESS
OTHERWISE SPECIFIED:

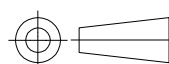

- 0 PLC ±
- 1 PLC ±
- 2 PLC ±
- 3 PLC ±
- 4 PLC ±
- ANGLES ±
- FINISH ±

MATERIAL

FINISH