

**TRIM TRIO
and SEALOK**
interconnection
system





FCI was created in 1989. The company is now the second largest connector manufacturer in the world and is the only European Company amongst the first 10 worldwide. Its activities are geared towards five major sectors: electronics, industrial, military and aerospace, electrical equipment, microelectronics and automotive.

FCI has its headquarters in Paris and employs more than 17,000 people in the world.

With more than 60 production plants in 28 countries, FCI accounts for approximately 50% of the total sales of the Framatome Group, of which the FCI company is a subsidiary.

**FCI
connects
the world**



TRIM TRIO and SEALOK products are produced by the Interconnections division of FCI. The products are marketed through the International sales organisations of FCI as indicated on the back page of this catalogue.

Connectors for Industrial markets

FCI Technology and Capability

Always attentive to the diversified needs of industrial equipment manufacturers, FC-Belgium has developed an unparalleled range of competitive options for signal and power applications addressing electronic controls, scientific and medical instrumentation, servo drives and motors for machine tools and robots.

In house capabilities such as research and development, product and tool design, moulding, stamping, plating and assembly, created a substantial knowledge base in material research of advanced plastics and moulding, as well as metal forming and plating techniques, that improve the performance capabilities of our connector products.

State-of-the art computer techniques have improved the precision of our connector designs and have reduced the overall cycle for new product developments and design-in projects.

FCI Commitment to Quality

FCI connectors for the Industrial markets are all produced with modern quality assurance methods to obtain the product reliability required by our customers. This commitment to quality has pursued ISO 9001 certification, ensuring that many aspects of our business are being continuously upgraded and refined to guarantee the continuation of our quality improvement achievements.





G - Bantamate



Description

Metal circular connector with metal bayonet coupling system

Range

Shell sizes: 8
Contact arrangements: 8 (4 to 48)

Features

Derived from MIL - C 26482
Intermateable with UTG / UTP and UTGS
IP65 (waterprotected version) - 5 sizes
Suitable for EMC requirements
Min 500 matings/unmatings

Accessories

Different types of cable clamps
Shielded cable clamp
Dustcaps
Discrimination pins

UTG - Metalok Bantam



Description

Plastic circular connector with metal bayonet coupling system

Range

Shell sizes: 8
Contact arrangements: 11 (3 to 48)

Features

Derived from MIL - C 26482
Intermateable with UTO / UTP
IP65 (waterprotected version)
Min 500 matings/unmatings
3 VDE versions, 2 power versions

Accessories

Different types of cable clamps
Dustcaps
Discrimination pins

UTP - Full plastic Bantam



Description

Full plastic circular connector with rugged plastic bayonet coupling system

Range

Shell sizes: 8
Contact arrangements: 10 (3 to 48)

Features

Derived from MIL - C 26482
Intermateable with UTO / UTG
IP65 (waterprotected version)
Min 250 matings/unmatings
2 VDE versions

Accessories

Different type of cable clamps
Dustcaps
Discrimination pins

UTGS - Shielded Bantam



Description

Metallised plastic circular connector with metal bayonet coupling system for EMC requirements

Range

Shell sizes: 8
Contact arrangements: 11 (3 to 48)

Features

Derived from MIL - C 26482
Intermateable with UTO
IP65 (waterprotected version)
Suitable for EMC requirements
Min 500 matings/unmatings
3 VDE versions

Accessories

Dustcaps
Discrimination pins

UTGW - SEALOK



Description

Plastic circular high density connector with metal bayonet coupling system, intermateable with MIL - C - 26482 Series I connectors

Range

Shell sizes: 7
Contact arrangements: 7 (6 to 61)

Features

Intermateable and intermountable with MIL - C 26482 Series I connectors
IP65 (waterprotected version)
Min 500 matings/unmatings
Military performance levels

Accessories

Different types of cable clamps
Dustcaps

MBG - Banatamate II



Description

Plastic circular connector with metal quick mating feature

Range

Shell sizes: 5
Contact arrangements: 5 (4 to 46)

Features

Min 5000 matings/unmatings
Quick and easy mating with latching system

Accessories

Cable clamp



MS-M Hyfen series

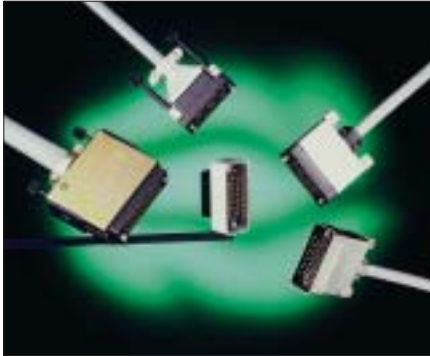

Description

High performance rectangular cable connector

Range

Shell sizes: 8
Contact arrangements: 8 (14 to 104)

Features

Per MIL - C 28748
Intermateable with MSO

Accessories

Different types of cable clamps
Guide and jackscrew pins
Pin protection shrouds
Discrimination pins

MSO series



Description

Rectangular boardmount connector to mate with MS-M cable connectors

Range

Shell sizes: 5
Contact arrangements: 5 straight (9 to 75)
3 right angle (9,18,34)

Features

Solid machined or stamped and formed contacts
Intermateable with MS-M

Accessories

Guide and jackscrew pins
Discrimination pins

V35 - DTE/DCE

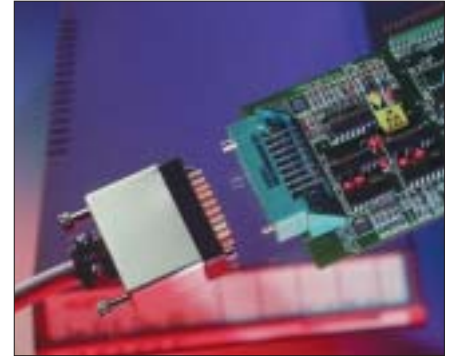

Description

Rectangular cable and boardmount connector for V.35 DTE/DCE interface applications

Range

1 shell size with 34 contact positions
straight and right angle boardmount connector

Features

In compliance with international standards of ISO 2593 for TSS V.35 interfacing
Solid machined or stamped and formed contacts for boardmount connector
Shielded cable and boardmount connectors available

Accessories

Different type of cable clamps (incl. shielded)
Guide and jackscrew pins
Pin protection shrouds and discrimination pins

SMS - Qikmate cable connectors



Description

Low cost rectangular cable connectors for cable to cable and cable to panel applications

Range

Shell sizes: 10
Contact arrangements: 10 (2 to 36)

Features

Intermateable with SMS Boardmount
Moulded-on cable hood
No extra hardware required
Positive locking with retaining latches
Discrimination cavities in between contact cavities

Accessories

Pin protection shrouds
Discrimination pins
Tie wraps

SMS - Qikmate boardmount



Description

Low cost rectangular boardmount connector to mate with SMS cable connectors

Range

Shell sizes: 10
Contact arrangements: 10 straight (2 to 36)
4 right angle (3,6,12,18)

Features

Solid machined or stamped and formed contacts
No extra hardware required
Intermateable with SMS cable connectors
Discrimination cavities in between contact cavities

Accessories

Discrimination pins

PI43 Eurorack connectors

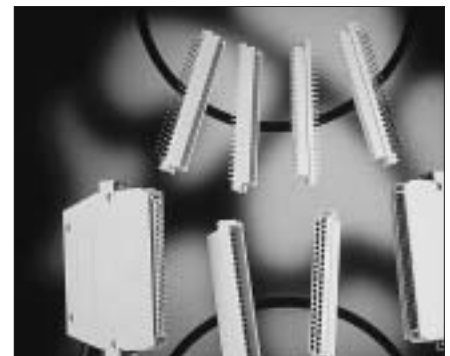

Description

Rectangular cable and boardmount connector manufactured to DIN41612 style C dimensions

Range

1 shell size with 43 contact positions
straight and right angle boardmount connector

Features

19" rack mounted
Designed to DIN41612 style C dimensions
Solid machined contacts for boardmount connector

Accessories

Cable clamps
Locking keys for front and backpanel applications



In house capabilities



R&D
Product engineering
Tool design
Manufacturing engineering



Toolroom



Moulding



Stamping



Plating



Assembly



• Circular connectors

Page

Circular introduction	Circular introduction	1
Metal circular connector	G – Bantamate	12
Plastic connector with metal coupling system	UTG – Metalok Bantam	17
Full plastic circular connector	UTP – Full plastic Bantam	21
Shielded connectors... how to assemble ...	Shielding, how to assemble...	24
Shielded connectors for EMC requirements	UTGS – Shielded Bantam	27
Specials	Circular specials	31
Plastic high density connector with metal coupling system	UTGW – Sealok	35
Circular accessories	Circular accessories	40
Plastic connector with quick mating feature	MBG – Bantamate II	48

• Rectangular connectors

Rectangular introduction	Rectangular introduction	52
High performance cable connectors	MS-M	53
Rectangular boardmount connectors	MS0	61
V.35 DTE/DCE interface connectors	V.35 DTE/DCE	66
Economical connectors	SMS – Qikmate	72
Eurorack connectors	PI43	87

• Contacts

Contacts introduction	Contacts introduction	99
Machined TRIM TRIO contacts	RM/RC	103
Stamped and formed TRIM TRIO contacts	SM-M/SC-M	106
Coax TRIM TRIO contacts	RMDX/RCDX	108
Stamped and formed SEALOK contacts	SM-W/SC-W	114
Fibre optic TRIM TRIO contacts	8012 – Fibre optic	116

• Accessories

Discrimination keys for TRIM TRIO connectors	Dicrimination keys	117
--	--------------------	-----

• Tooling

Tooling introduction	Tooling introduction	119
Crimp and extraction tooling for TRIM TRIO and SEALOK contacts	Crimptooling1	120



TRIM TRIO – The principle

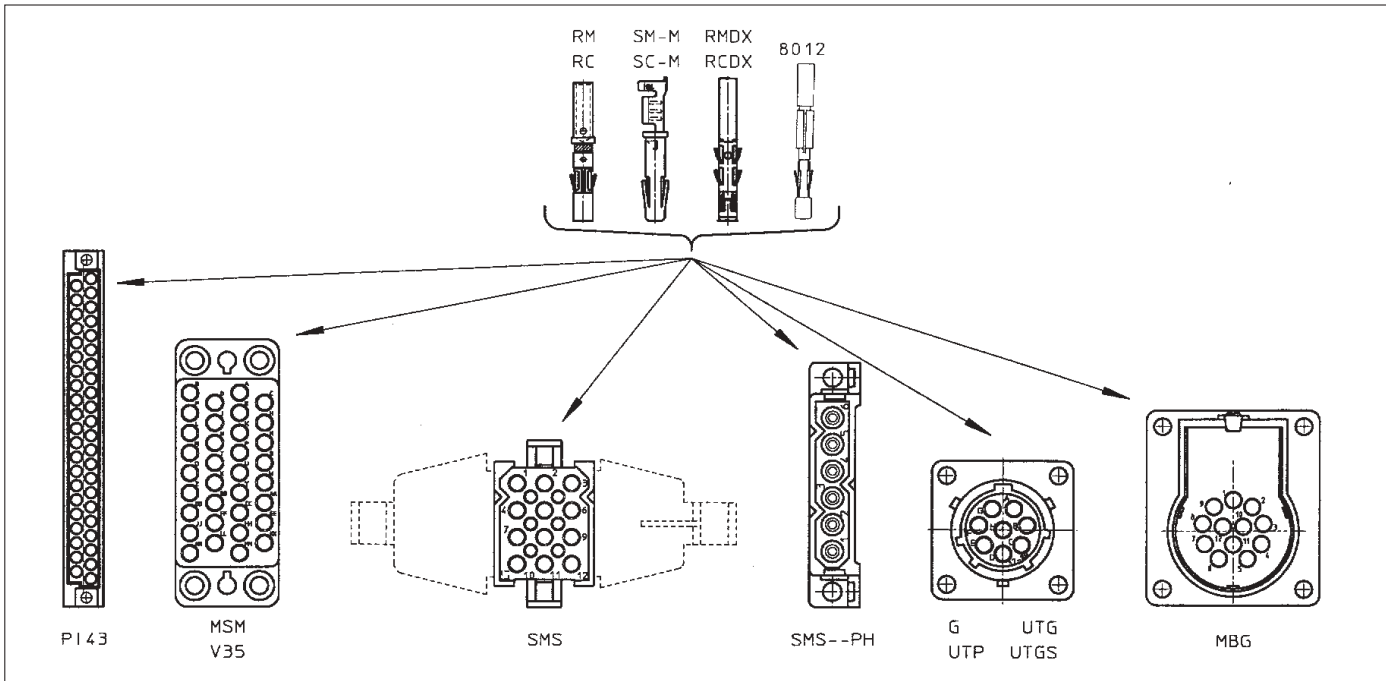

The TRIM TRIO interconnection system is a fully integrated system, in which 4 contact types can be used in a variety of connector styles and sizes, ranging from 1 to 104 contact positions.

This interchangeability offers boundless design possibilities with a large commonality throughout the entire range.

The commonality in the system is established in:

- contact performance and wire range.
- configuration of contact cavities in the housings.
- crimp tooling
- assembly procedures.
- quality assurance procedures.
- field service and maintenance.
- personnel training.

Products

The contacts, both male and female, accommodate a wire range of AWG14 up to AWG30. The 4 contact families are:

- machined contacts for high performance (up to 13 Amp current rating), with gold or tin plating.
- stamped and formed two-piece contacts, for more cost effective applications (up to 13 Amp current rating).
- subminiature coaxial contacts, in a multi-piece and a mono-crimp version, for coaxial or twisted-pair cables.
- Fibre optic contacts to accommodate 1000 μ plastic fibres with a cable diameter of 2.2 mm.

The housings offer many options in contact cavities and backshell possibilities.

The main versions are:

- circular connectors:
 - full metal
 - plastic with metal coupling system
 - full plastic
 - metallised plastic for shielding
 - plastic with quick mating feature
- rectangular, high performance, rack and panel and printed circuit board versions.
- rectangular, low cost, rack and panel and printed circuit board versions.
- rectangular connectors for V.35 applications.
- rectangular connectors for eurorack applications.

(See TRIM TRIO selection matrix on the next page)

The beauty of the TRIM TRIO system means that the 4 contact types can be combined (both male and female) in any TRIM TRIO connector type of any geometry.

The keywords in the TRIM TRIO interconnection system are standardisation, versatility, reliability and economy. These words explain why the TRIM TRIO name is so well known, and its connectors are used all over the world.

Standardisation

- The same contact cavity for each type of housing
- identical crimp tooling for all types of contacts except fibre optics

- reduced manufacturing methods
- standardised operator training
- international acceptance

Versatility

- wide range in current capability
- various contact platings
- wire and cable accommodations
- housings accommodate pin and socket (male and female) contacts
- variety of terminations
- variations in mounting
- number of sizes
- discrimination keying
- broad range of installation tooling
- variety of possible applications

Reliability

- proven materials
- guaranteed quality assurance per ISO 9001 certification
- rigid inspection procedures
- positive polarisation
- pin protection
- rugged mouldings
- restricted entry contacts

Economy

- low assembly cost
- minimal tooling downtime
- easy connecting and disconnecting
- low wiring cost
- simplified personnel education
- low inspection cost
- removable contacts
- reduced number of components
- low installed cost



Versatility

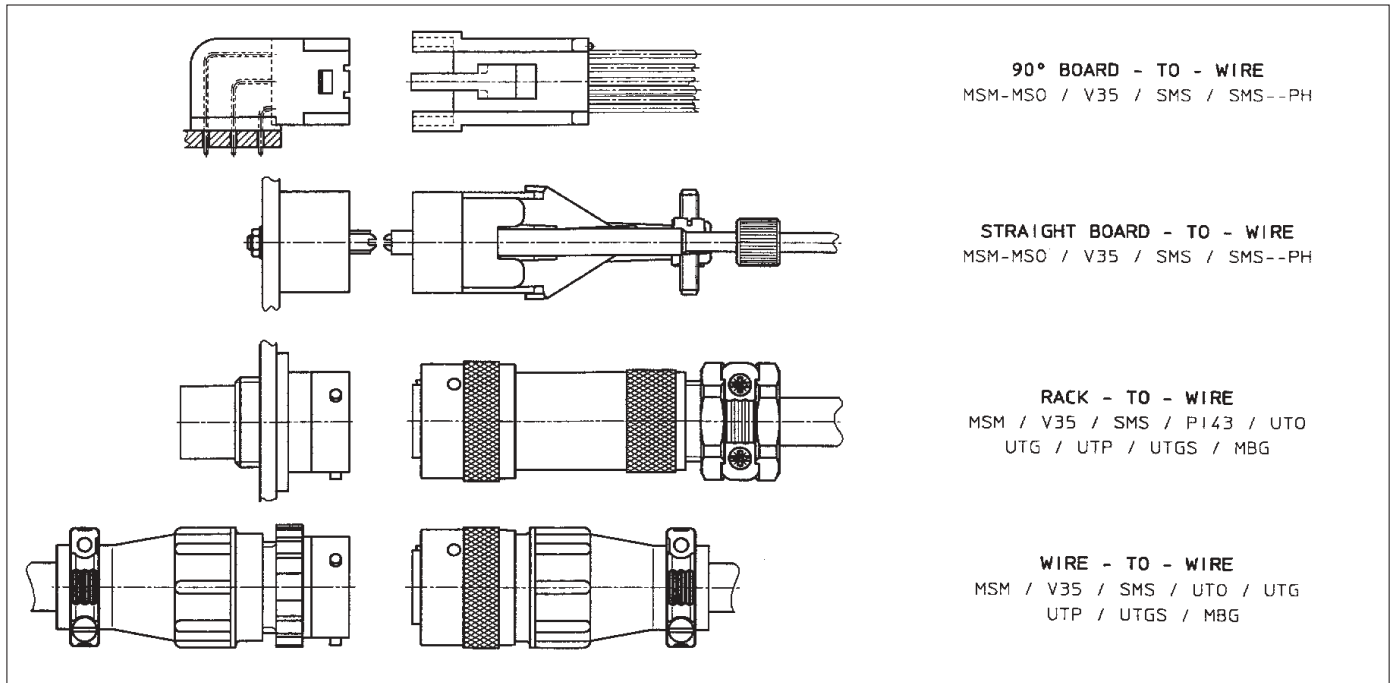

TRIM TRIO selection matrix

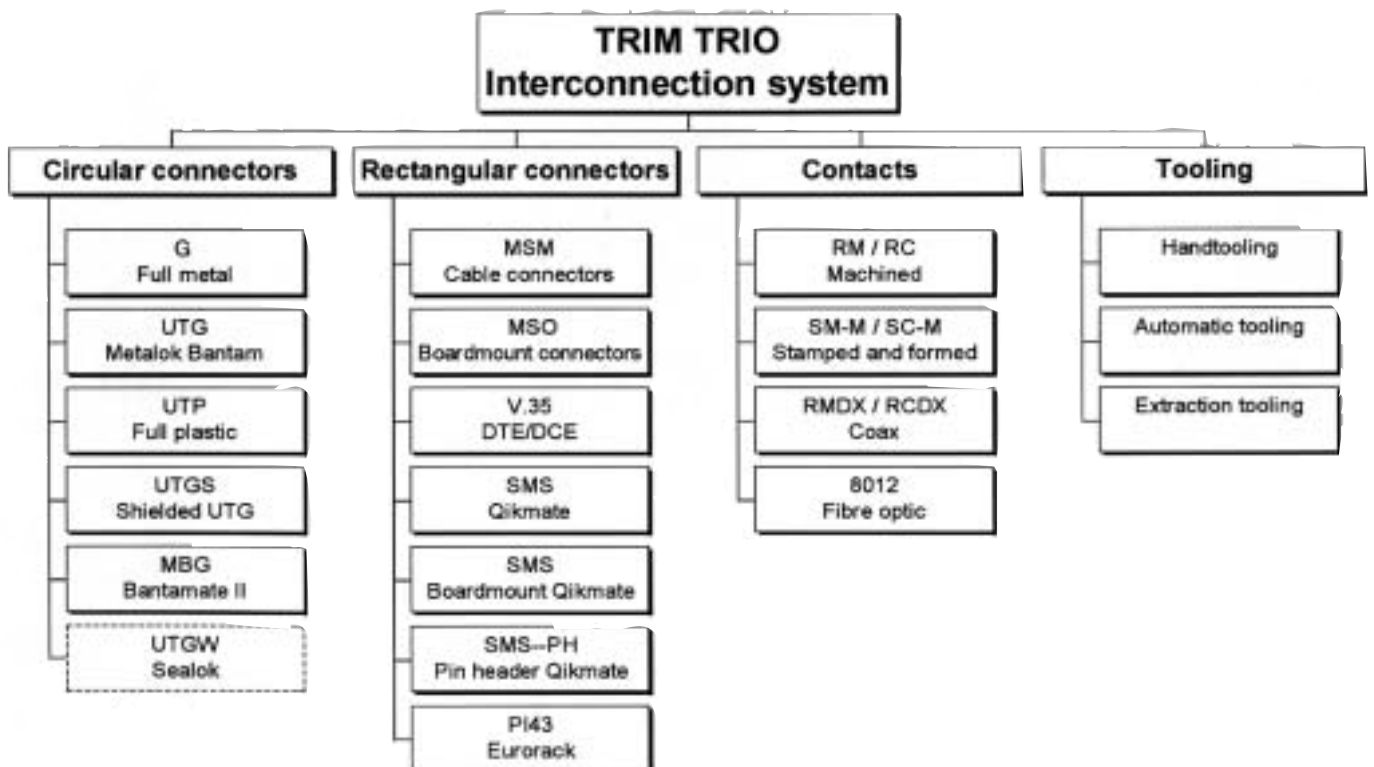



Description

The TRIM TRIO and SEALOK circular connectors are an integrated group of economical, reliable, versatile standardised connectors for a broad spectrum of interconnection applications. Being derived from MIL-C-26482, input and output connections can be made with a large number of sizes ranging from:
 4 to 48 contact positions in TRIM TRIO
 4 to 46 contact positions in MBG Bantamate II
 6 to 61 contact positions in SEALOK

What are the links and differences between TRIM TRIO circular, MBG Bantamate II and SEALOK ?

To avoid misunderstandings on the circular connector ranges, it has to be clearly understood that there are inevitable links and differences between all the circular product ranges (see fig).

Intermateability

- TRIM TRIO circular connectors are available in G, UTG, UTP and UTGS and are fully intermateable, interchangeable and intermountable.
- MBG Bantamate II with his unique quick mating feature plus high number of mating cycles is not mateable with other TRIM TRIO circular connectors.
- SEALOK is derived from UTG range in TRIM TRIO and is fully intermateable and intermountable with MIL-C-26482 (62GB) and VG-95328 connectors.

Contacts

- TRIM TRIO and MBG Bantamate II circular connectors are using the size 16 TRIM TRIO contacts available in machined, stamped and formed, coax and fibre optic versions.
- SEALOK uses size 20 SEALOK contacts, only available in stamped and formed versions.

Accessories

- TRIM TRIO and Sealok use the same accessories such as backshells and dustcaps.
- MBG Bantamate II has his own backshell

Tooling

- TRIM TRIO and MBG Bantamate II and SEALOK use all the same crimp barrels per wire size and the same crimp tooling.

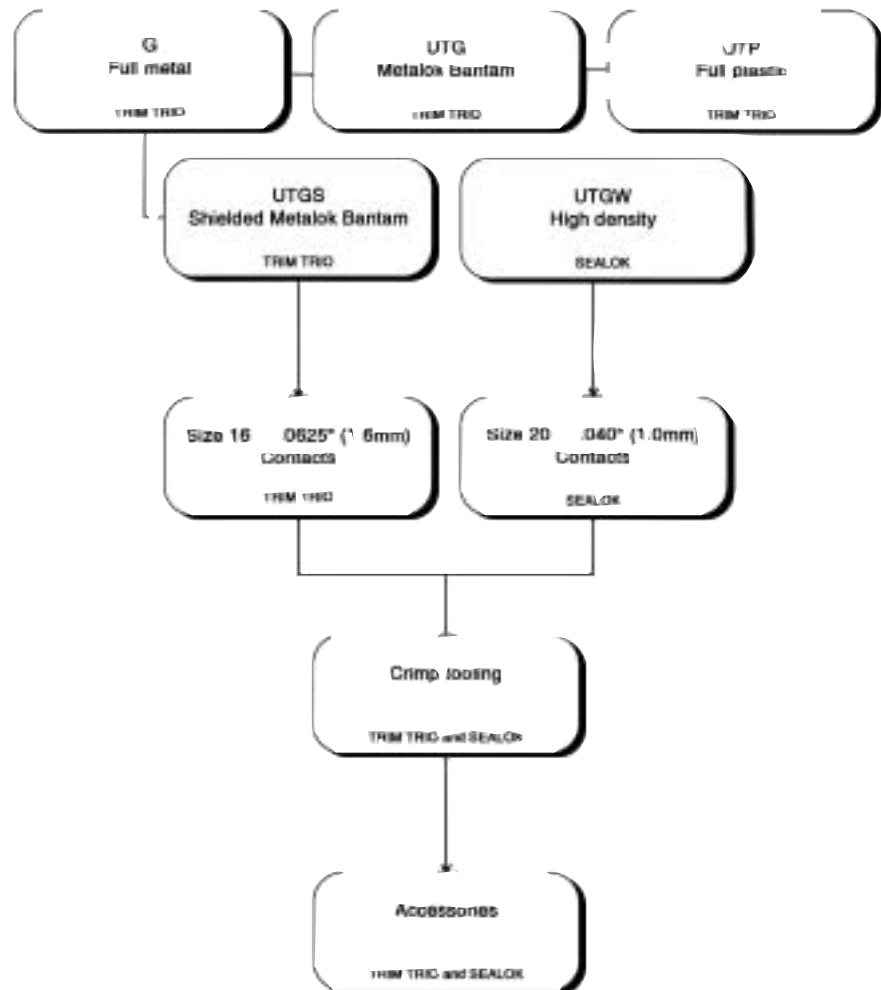



Selection matrix Circular connectors

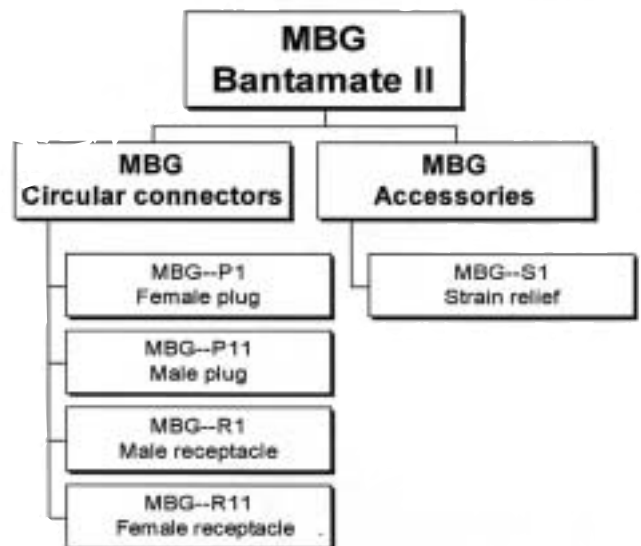
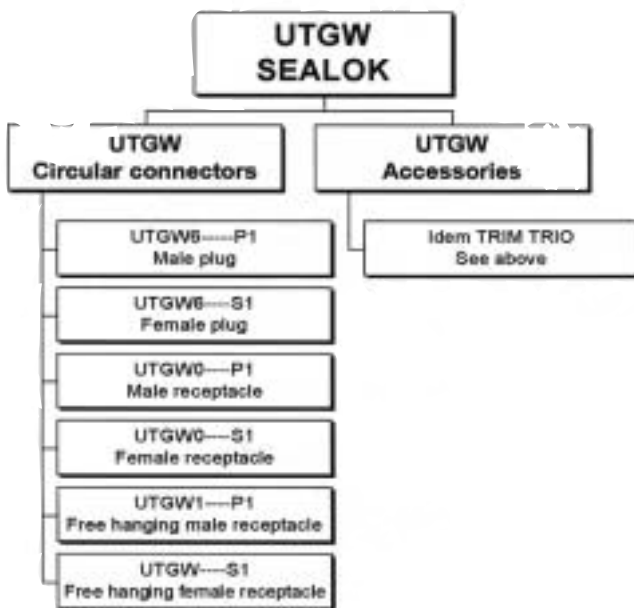
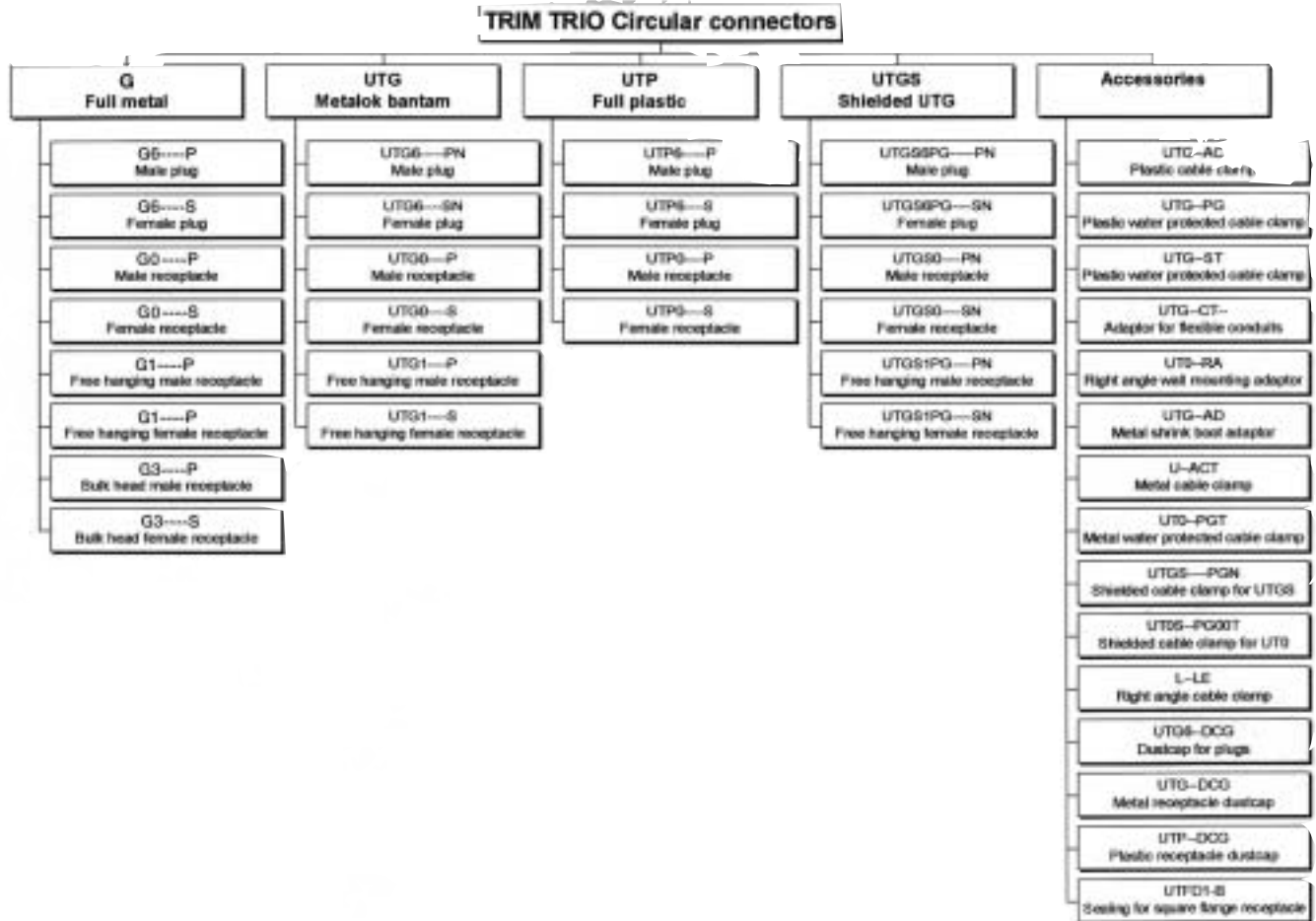



TRIM TRIO Insert arrangements and moulded-in contact identification

TRIM TRIO arrangements only available for UTG, UTGS and UTP

SIZE
10-4



SIZE
12-8

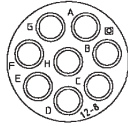

SIZE
14-12

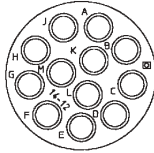

SIZE
16-19

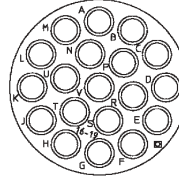

SIZE
18-23

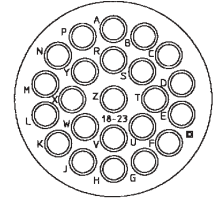

SIZE
20-28

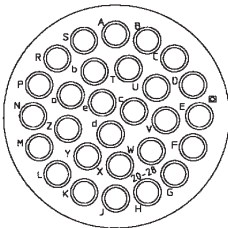

SIZE
22-35

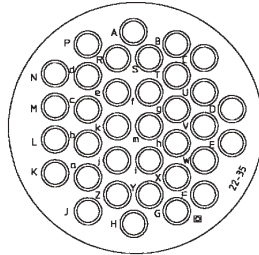

SIZE
24-48

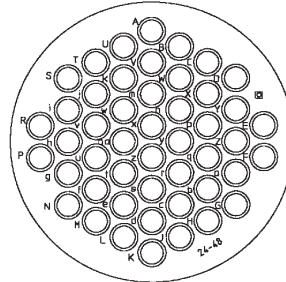

TRIM TRIO additional arrangements only available for UTG, UTGS and UTP

SIZE 10-3
VDE 0110
GROUP C 250 V



SIZE 18-7
VDE 0110
GROUP C 380 V

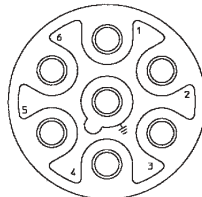

SIZE 20-20
VDE 0110
GROUP C 660 V

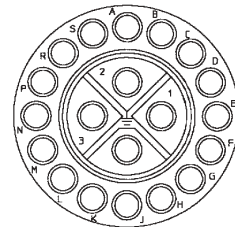

Contact identification positions shown are for mating face of pin contact, connectors, and wire face of socket contact connectors.



Trim Trio G Series Insert Arrangements

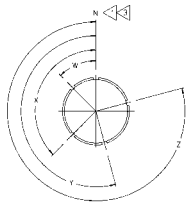
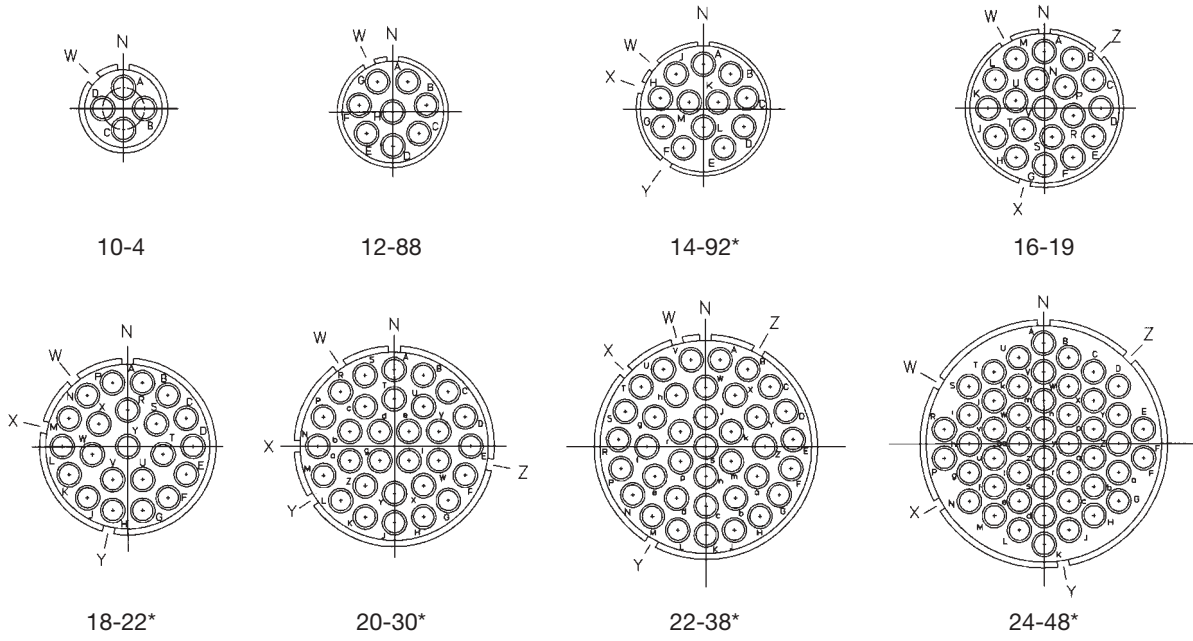

Alternate Keyway Positions

- ▶ Typical mating face of pin insert shown. (Socket insert opposite) 'N' Normal position 0°. Polarization letters show master key position with respect to contact hole identification characters.
- ▶ Unless otherwise specified 'N' keyway is standard position on all keyways, angles given are counter clockwise from 'N' position. (Socket insert opposite)

Shell Size	Arrang. No.	Insert Position In Shell			
		W	X	Y	Z
10	4	45°	—	—	—
12	88	26°	—	—	—
14	92	49°	71°	145°	—
16	19	30°	165°	—	315°
18	22	39°	77°	167°	—
20	30	34°	90°	123°	259°
22	38	15°	47°	150°	331°
24	48	60°	120°	189°	315°

*Also available in interfacial seal version. To order, add suffix number 21 to standard catalog number.

SEALOK insert arrangements

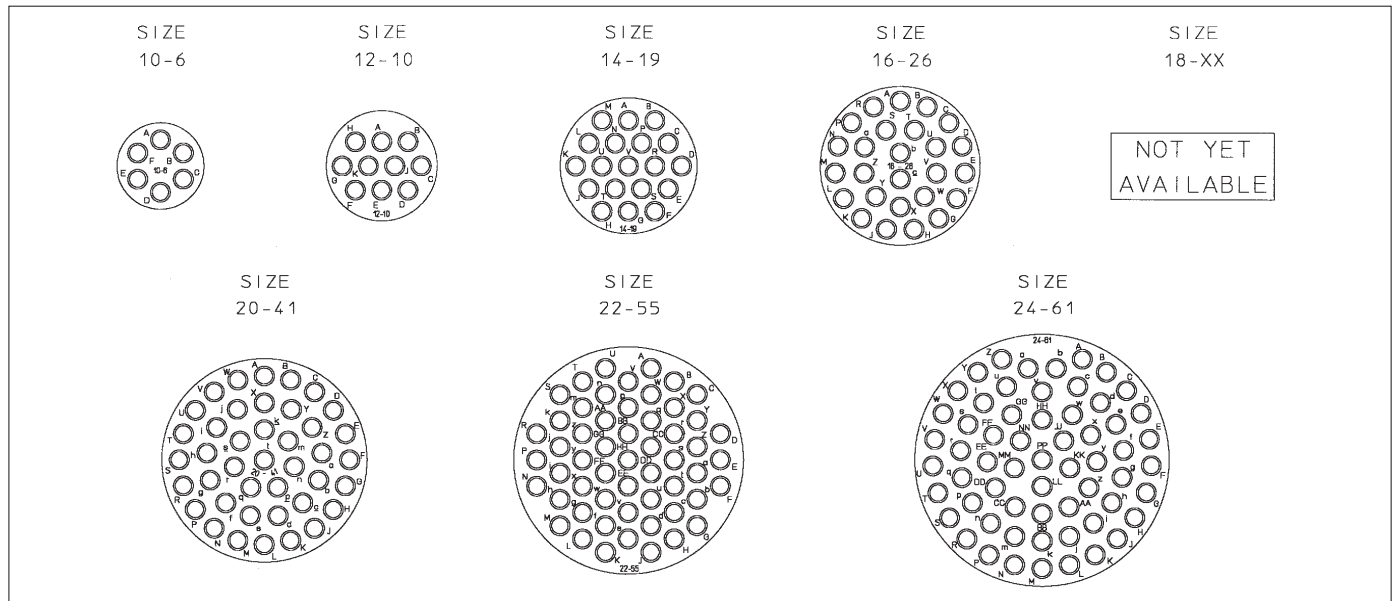

Marking on wiring face is moulded-in.
 Marking on mating face is moulded-in for socket versions. For pin versions, each mating face has an interfacial seal with silkscreen marking.

Mating Dimensions TRIM TRIO and SEALOK

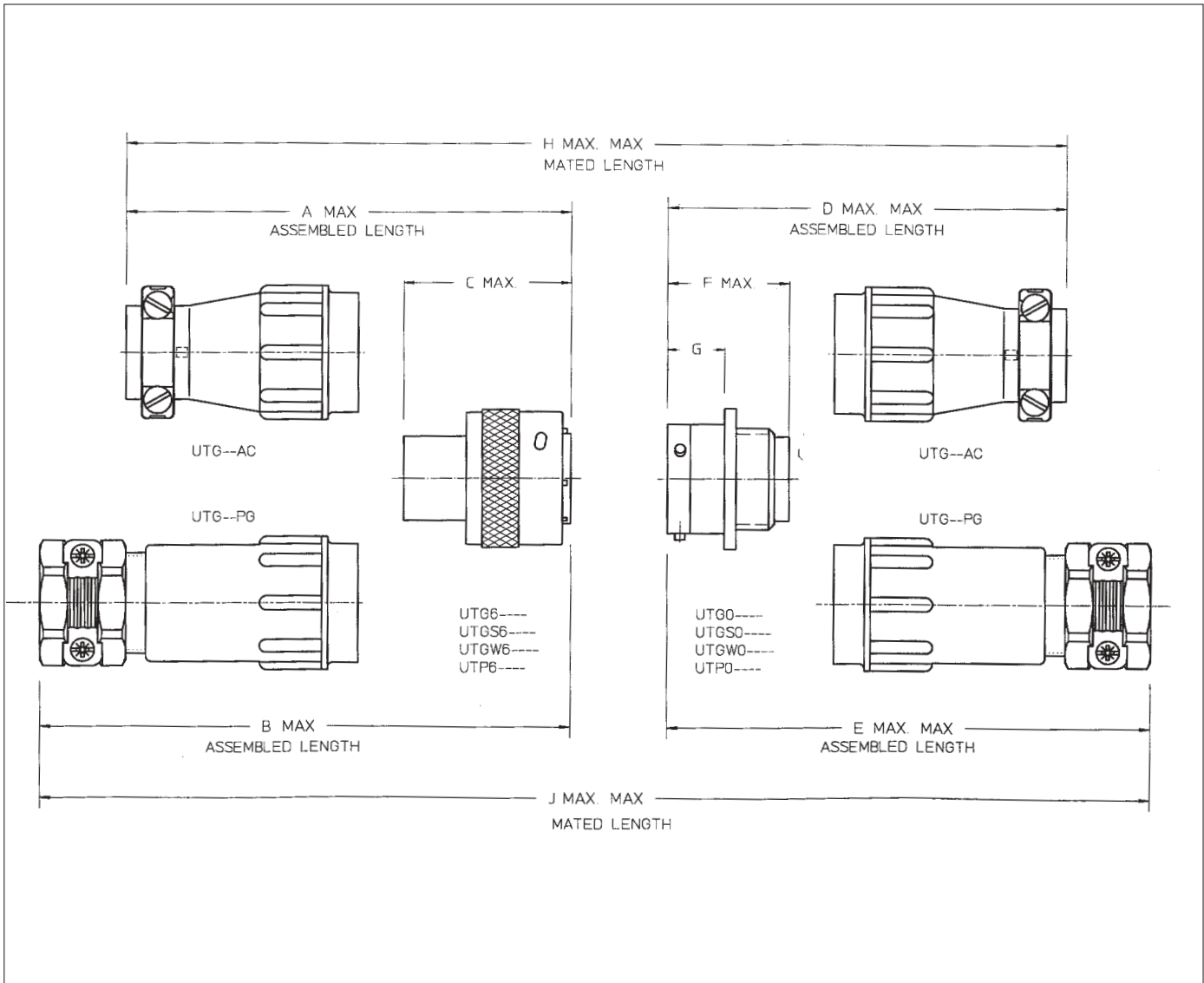

Shell size	Dimensions in mm										
	A max.	B max.	C max.	D max.	E max.	F max.	G ^{±0.2}	H max.	J max.		
10	57	72	31.8	57.5	72.5	24.3	11.4	106	136		
12		74			74.0				139		
14	63	81		63.5	81			26	14.6	118	153
16		85		85	161						
18	67	88		67.5	89	26	15.4	126	168		
20	74	101		76	103			140	191		
22	79	117		82	110	26	15.4	151	207		
24	84	123		88	127			162	240		
10-3VDE	57	72			57.5	72.5	31.7	11.4	106	136	
18-7 VDE	73.5	94.5		33	74	95.5	34	17.9	133	175	
20-20VDE	74	101	31.8	76	103	26	14.6	140	191		



TRIM TRIO cavity dimensions on wire face

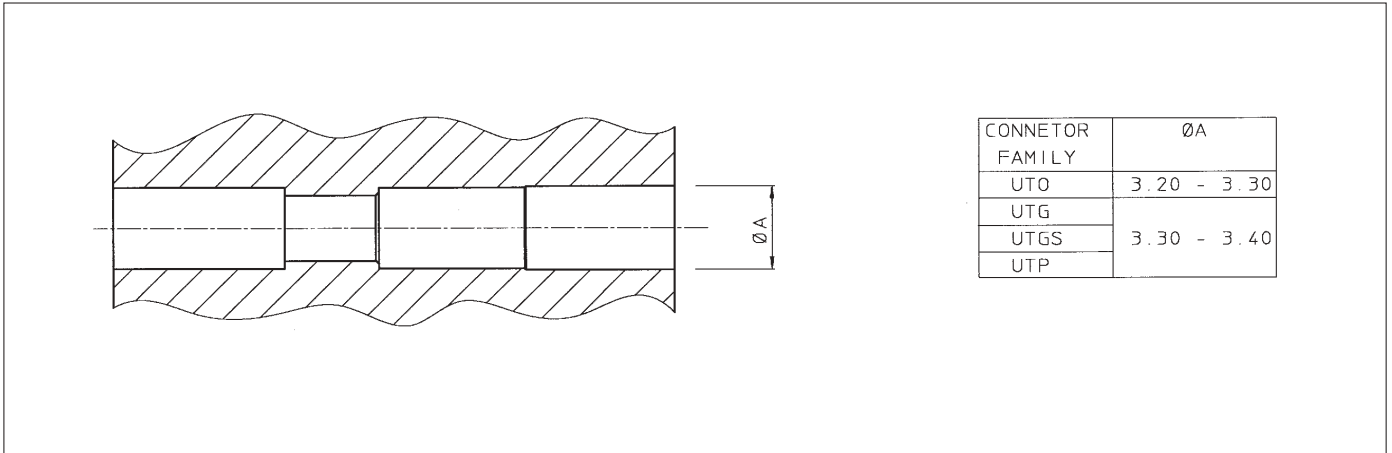

SEALOK cavity dimensions on wire face

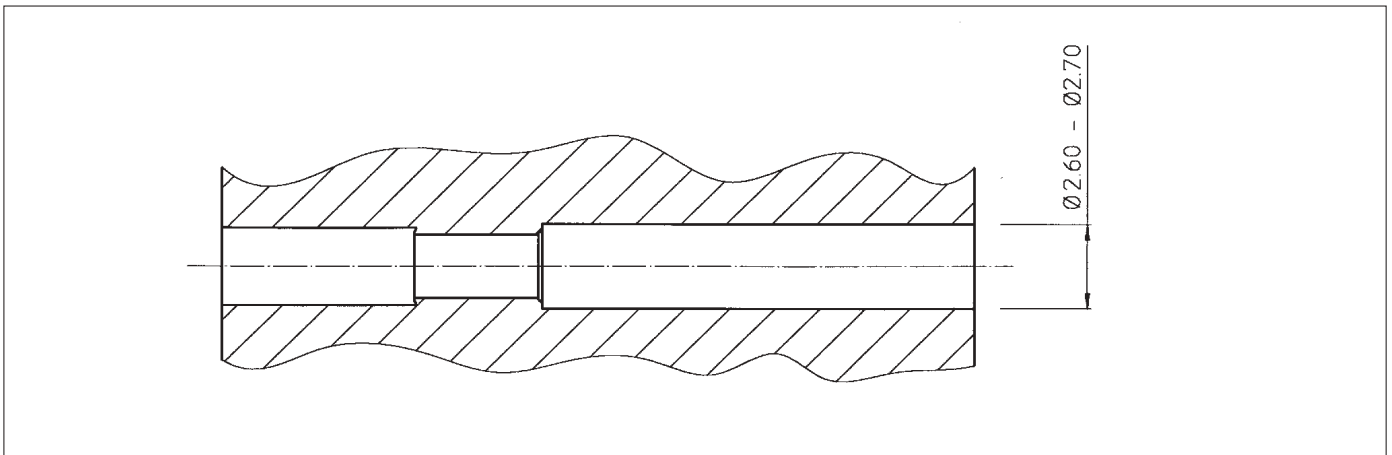

TRIM TRIO and SEALOK threading dimensions

Shell size	Shell thread size for backshells	PG - thread on PG cable clamp
10	9/16 - 24 UNEF	PG9
12	11/16 - 24 UNEF	PG11
14	13/16 - 20 UNEF	PG13.5
16	15/16 - 20 UNEF	PG16
18	1-1/16 - 18 UNEF	
20	1-3/16 - 18 UNEF	PG21
22	1-5/16 - 18 UNEF	
24	1-7/16 - 18 UNEF	PG29



Metal circular connector

(Suitable for EMC requirements)

Description

“G” Bantam industrial circular connectors are a range of multiway connectors available in 8 shell sizes and 8 insert arrangements, interchangeable and intermountable with the Trim-Trio “UTG”, “UTGS” and “UTP industrial connector families.

“G” is equipped with identical shells from military connectors complying to MIL-C-26482 spec.

Strong and rugged built to resist every environmental and mechanical requirement for indoor and outdoor applications.

In combination with the shielded backshell, “G” offers the perfect solution to EMC requirements.

Features and benefits

- Suitable for EMC requirements.
- Shielded backshell is independent of the cable diameter and its shielding.
- Available in 8 shell sizes and 8 insert arrangements.
- Available in plug and receptacle version for both male and female contacts.
- Shells and accessories are made from tin plated corrosion resistant Aluminium.
- Plastic inserts with flammability rating: UL94-V0.
- Alu. bayonet ring:
 - Metal wave spring loaded.
 - Locks with audible positive “click”
 - Assures 500 matings and unmatings

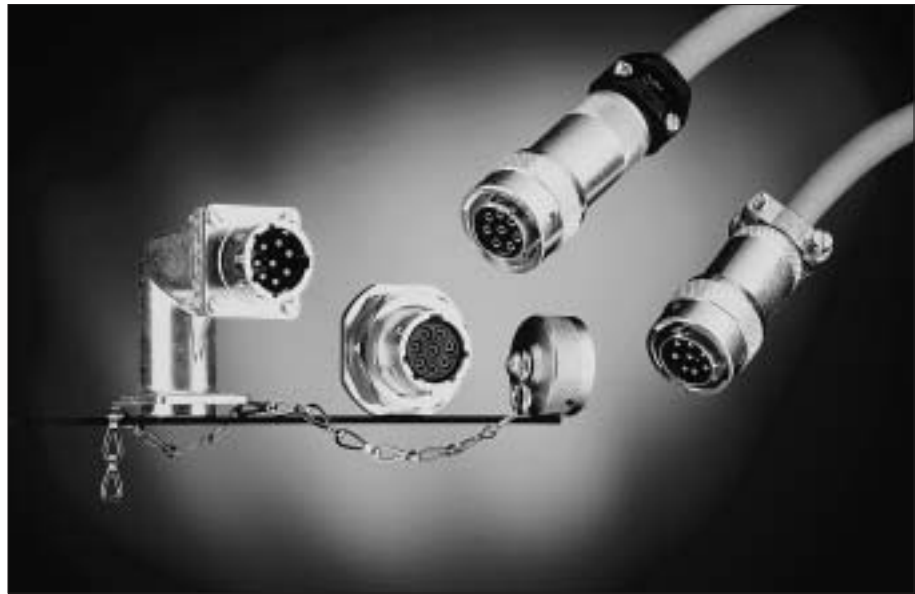

Performance characteristics

Operating temperature:	-55°C to +125°C
Insulation resistance:	5000 MΩ min.
Test potential:	2000 VAC
Durability:	500 matings and unmatings.
Vibration resistance:	Per MIL-STD202 method 204
Thermal shock:	Per MIL-STD202 method 207
Corrosion:	Salt spray per MIL-STD 202 method 101
Shielding effectiveness:	95 dB at 1 Mhz (see shielded connectors section)
Degree of protection per DIN 40050:	IP65 in mated condition. “21” version used with UTG-PG cable clamp

Construction

Shells and accessories:	Aluminium alloy
Coupling ring:	Aluminium alloy
Tri-lock pins:	Stainless steel
Coupling spring:	Spring steel
Insert:	Glass-filled thermoset UL94-V0
Finish:	Cadmium plate (standard)

Contact accommodation

- “G” connectors accept Trim-Trio crimp-type removable snap-lock contacts (see contacts section)
- Contacts to be ordered separately.

How to order

	G	0	A	16	19	P	N	H	21
Type:	0-1-2-6-4-3-7-8-9								
Termination Class:	A-B-F-L-J-JF-P								
Shell Size:	10-12-14-16-18-20-22-24								
Insert Arrangement:	4-88-92-19-22-30-38-48								
Contact Type:	P: pin - S: socket								
Insert Polarization:	N-W-X-Y-Z								
Finish:	H-E								
Interfacial Seal (optional):	Available in Shell sizes 14, 18, 20, 22 and 24								

Cable plug for pin contacts (G6B- - - -P--)

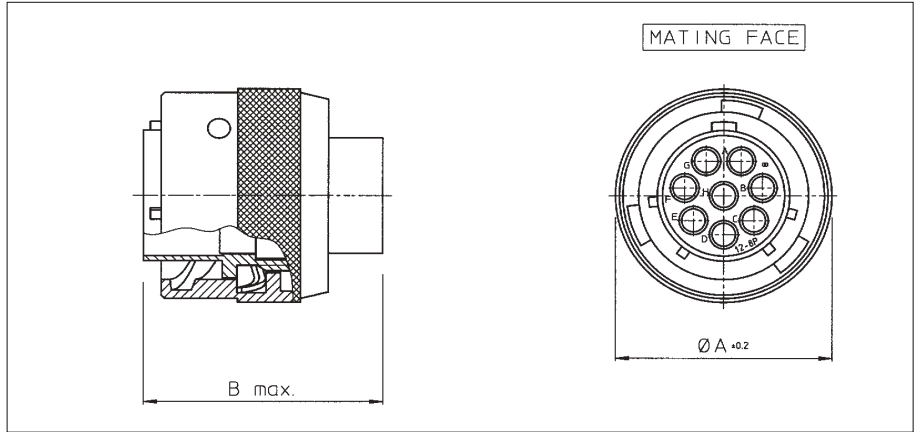

Part number	Shell size	$\varnothing A \pm 0.2$	B max.
G6B10-4P--	10	21.39	31.06mm 1.223 in.
G6B12-88P--	12	24.74	
G6B14-92P--	14	27.74	
G6B16-19P--	16	31.12	
G6B18-22P--	18	34.09	
G6B20-30P--	20	37.47	
G6B22-38P--	22	40.44	
G6B24-48P--	24	43.99	

Cable plug for socket contacts (G6B- - - -S--)

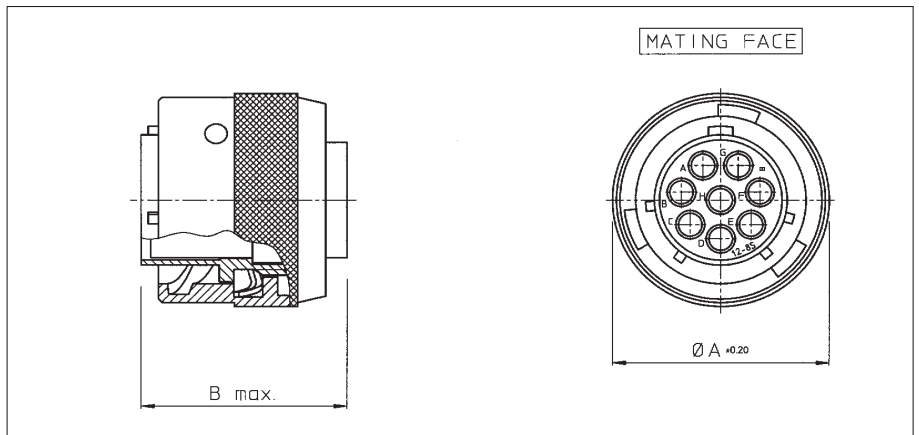

Part number	Shell size	$\varnothing A \pm 0.2$	B max.
G6B10-4S--	10	21.39	24.18mm
G6B12-88S--	12	24.74	
G6B14-12S--	14	27.74	
G6B16-19S--	16	31.12	25.93mm
G6B18-22S--	18	34.09	
G6B20-30S--	20	37.47	27.53mm
G6B22-38S--	22	40.44	
G6B24-48S--	24	43.99	



Wall mounting receptacle for pin contacts (G0B- - -P--)

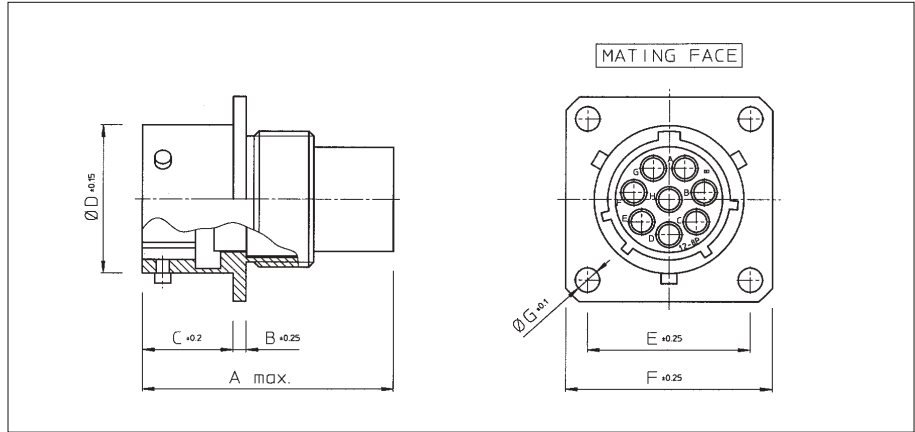

Part number	Shell size	A max.	B ±0.25	C ±0.2	Ø D ±0.15	E ±0.25	F ±0.25	Ø G ±0.1
G0B10-4P--	10	31.29	1.6	10.95	14.99	18.26	24.23	3.05
G0B12-88P--	12				19.05	20.62	26.59	
G0B14-92P--	14				22.23	23.01	28.98	
G0B16-19P--	16				25.40	24.61	31.34	
G0B18-22P--	18				28.58	26.97	33.73	
G0B20-30P--	20	32.87	2.4	14.12	31.75	29.36	36.91	3.73
G0B22-38P--	22			34.93	31.75	40.08		
G0B24-48P--	24			14.96	38.10	34.93	43.26	

Wall mounting receptacle for socket contacts (G0B- - -S--)

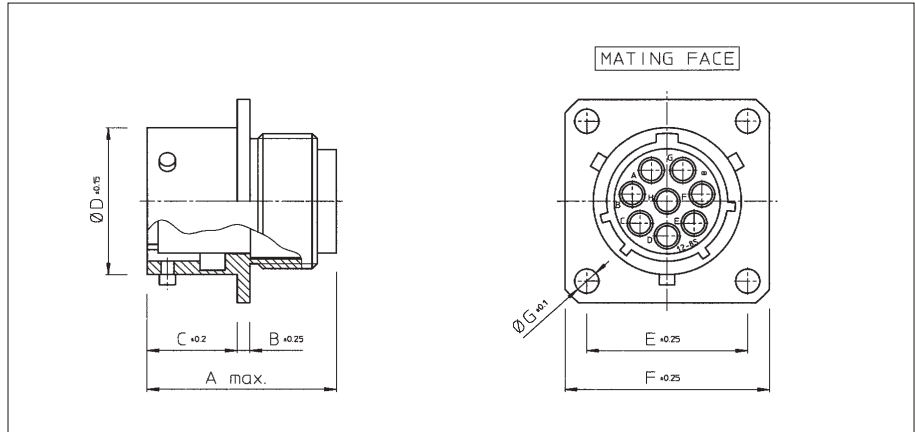

Part number	Shell size	A max.	B ±0.25	C ±0.2	Ø D ±0.15	E ±0.25	F ±0.25	Ø G ±0.1
G0B10-4S--	10	24.41	1.6	10.95	14.99	18.26	24.23	3.05
G0B12-88S--	12				19.05	20.62	26.59	
G0B14-92S--	14				22.23	23.01	28.98	
G0B16-19S--	16				25.40	24.61	31.34	
G0B18-23S--	18				28.58	26.97	33.73	
G0B20-30S--	20	27.74	2.4	14.12	31.75	29.36	36.91	3.73
G0B22-38S--	22	34.93		31.75	40.08			
G0B24-48S--	24	29.34		14.96	38.10	34.93	43.26	



Free hanging receptacle for pin contacts (G1B- - -P--) - suitable for cable to cable applications

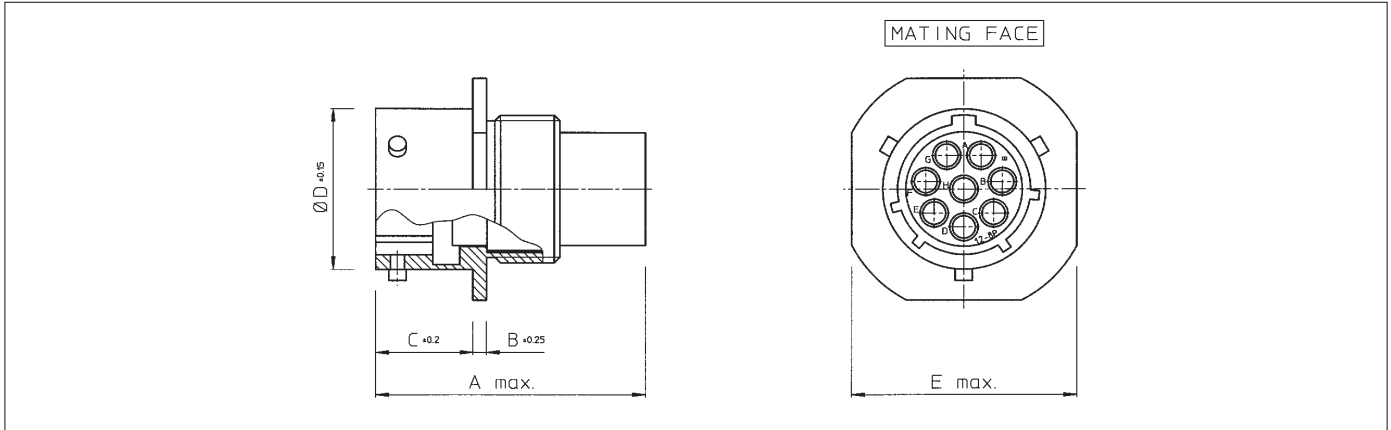

Part number	Shell size	A max.	B ± 0.25	C ± 0.2	$\varnothing D_{\pm 0.15}$	$\varnothing E_{max.}$
G1B10-4P--	10	31.29	1.6	2.4	14.99	24.23
G1B12-88P--	12				19.05	26.59
G1B14-92P--	14				22.23	28.98
G1B16-19P--	16				25.40	31.34
G1B18-22P--	18				28.58	33.73
G1B20-30P--	20	32.87	2.4	2.9	31.75	36.91
G1B22-38P--	22				34.93	40.08
G1B24-48P--	24				38.10	43.26

Free hanging receptacle for pin contacts (G1B- - -S--) - suitable for cable to cable applications

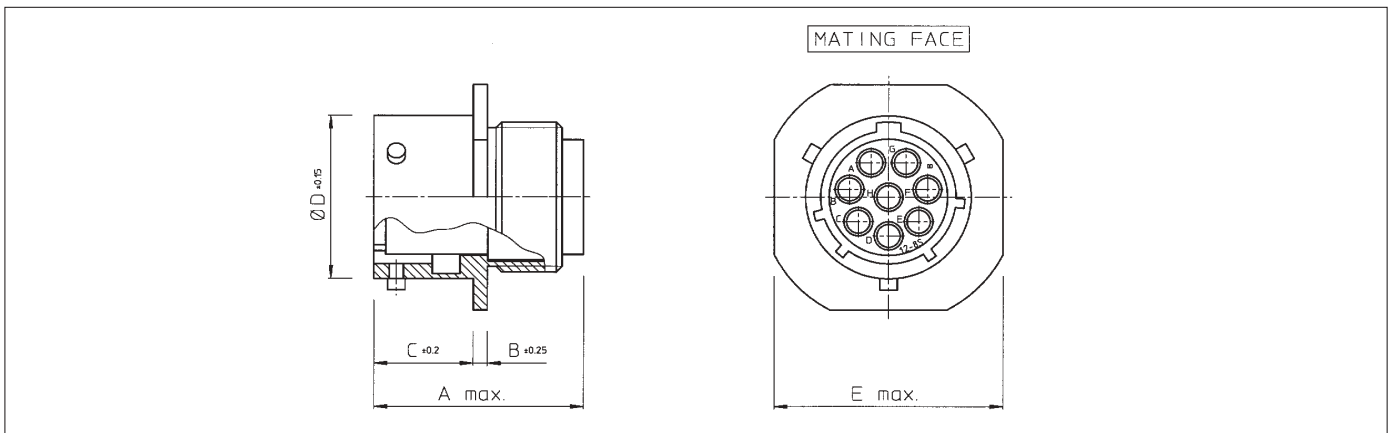

Part number	Shell size	A max.	B ± 0.25	C ± 0.2	$\varnothing D_{\pm 0.15}$	$\varnothing E_{max.}$
G1B10-4S--	10	24.41	1.6	2.4	14.99	24.23
G1B12-88S--	12				19.05	26.59
G1B14-92S--	14				22.23	28.98
G1B16-19S--	16				25.40	31.34
G1B18-22S--	18				28.58	33.73
G1B20-30S--	20	27.74	2.4	2.9	31.75	36.91
G1B22-38S--	22	34.93			40.08	
G1B24-48S--	24	29.34			38.10	43.26



Bulk head receptacle for pin contacts (G3B- - - -P--) - suitable for rear panel mounting

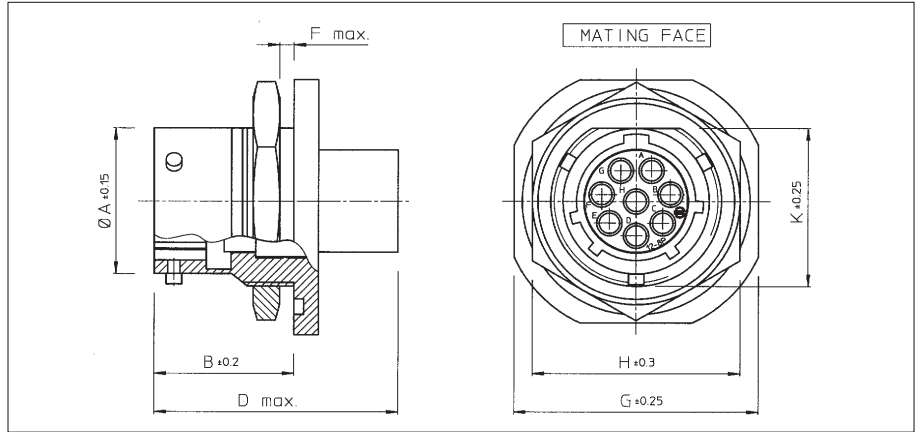

Part number	Shell size	A ±0.15	B ±0.2	D max.	F max.	G ±0.25	H ±0.2	K ±0.2
G3B10-4P--	10	14.99	17.55	31.29	3.18	27.38	22.66	16.64
G3B12-88P--	12	19.05				20.78		
G3B14-92P--	14	22.23				23.93		
G3B16-19P--	16	25.40				27.08		
G3P18-23P--	18	28.58				30.25		
G3B20-30P--	20	31.75	22.33	32.87	6.35	46.43	40.11	33.43
G3B22-38P--	22	34.93	36.60					
G3B24-48P--	24	38.10	23.16			52.78	48.06	39.78

Bulk head receptacle for pin contacts (G3B- - - -S--) - suitable for rear panel mounting

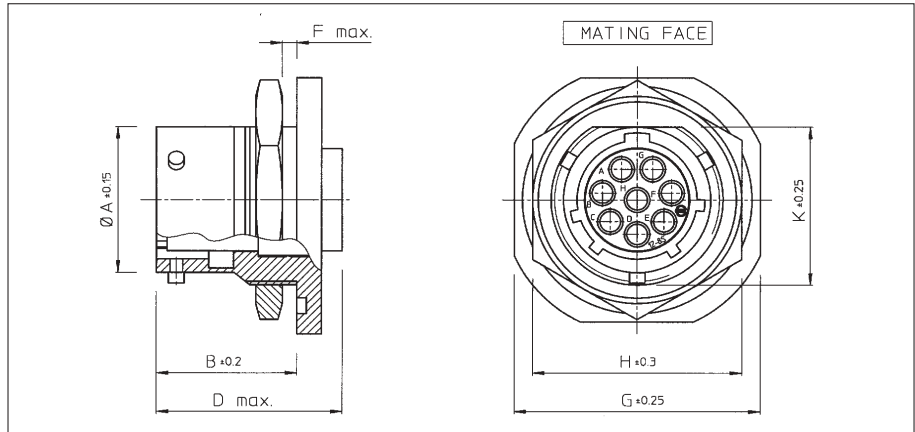

Part number	Shell size	A ±0.15	B ±0.2	D max.	F max.	G ±0.25	H ±0.2	K ±0.2
G3B10-4S--	10	14.99	17.55	24.41	3.18	27.38	22.66	16.64
G3B12-88S--	12	19.05				20.78		
G3B14-92S--	14	22.23				23.93		
G3B16-19S--	16	25.40				27.08		
G3P18-23S--	18	28.58				30.25		
G3B20-30S--	20	31.75	22.33	27.74	6.35	46.43	40.11	33.43
G3B22-38S--	22	34.93	36.60					
G3B24-48S--	24	38.10	23.16			29.34	52.78	48.06



Plastic connector with metal coupling system

Description

“UTG” Metalok Bantam plastic industrial circular connectors with metal coupling are a range of multiway connectors to provide the complete answer to the need for lightweight, robust circular connectors. They are available in 8 shell sizes, 11 insert arrangements all interchangeable, interchangeable and intermountable with the Trim-Trio “UT0” and “UTP industrial connector families.



Features and benefits

- Available in 8 shell sizes and 11 insert arrangements incl. 3 VDE versions and one power version.
- Available in plug and receptacle versions for both male and female contacts.
- Connectors and accessories are moulded from highly durable glass-filled thermoplastic.
- Flammability rating: UL94-V0.
- UL approved-file Nr.: E31151
- Metal bayonet ring:
 - Metal wave spring loaded.
 - Locks with audible positive “click”
 - Assures 500 matings and unmatings

Performance characteristics

Operating temperature:	-55°C to +125°C
Insulation resistance:	5000 MΩ min.
Test potential:	2000 VAC
Durability:	500 matings and unmatings.
Vibration resistance:	Per MIL-STD202 method 204
Thermal shock:	Per MIL-STD202 method 207
Degree of protection per DIN 40050: IP65 in mated condition. “H” version used with UTG —PG cable clamp	

Construction

Connector body	Glass filled thermoplast UL94-V0
	Colour: black
Coupling ring:	Nickel plated brass
Tri-lock pins:	Stainless steel
Coupling spring:	Spring steel

Contact accommodation

- “UTG” connectors accept Trim-Trio crimp-type removable snap-lock contacts (see contact section)
- Contacts to be ordered separately.

How to order

Connector family :	UTG	0	14	12	P	--	--	B	
	UTG	6	14	12	S	N	--	B	
Body variation:	0 : Wall mounting receptacle 6 : Cable plug 1 : Free hanging receptacle								
Shell size:									
Insert arrangement:									
Type of contacts:	P : Pin contacts S : Socket contacts								
Plating	N : Nickelplated bayonet ring (Plug Part Numbers Only)								
Application	No letter : Standard version H : Water protected version (only receptacle)								
Design variation	No letter : Moulded-in contact marking (standard version) Others : Specials versions								
Packing:	No letter: Standard version: Each connector individually packed in plastic bag B: Bulk packing per qty of 100 pcs								



Cable plug for pin contacts (UTG6- - - -PN)

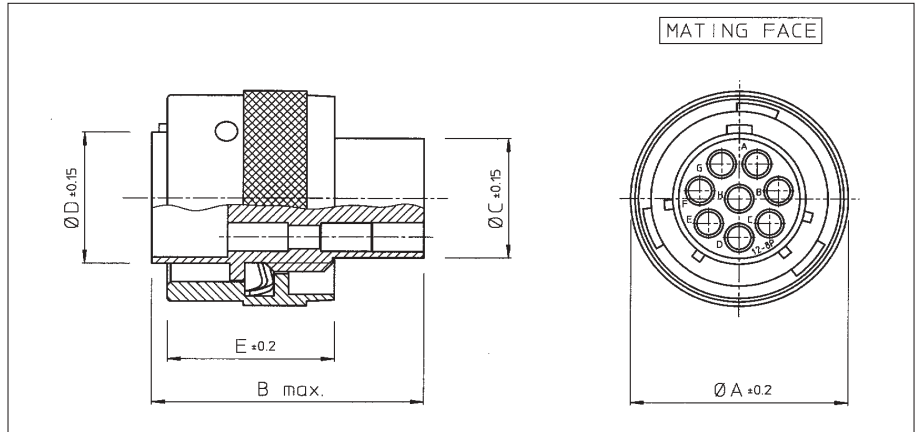

Part number	Shell size	Ø A ±0.2	B max.	Ø C ±0.15	Ø D ±0.15	E ±0.2
UTG6104PN / UTG6103PNVDE	10	21.6	31.8	10.9	12.2	19.1
UTG6128PN	12	24.8		13.8	15.1	
UTG61412PN	14	28.0		17.0	18.3	
UTG61619PN	16	31.2		19.9	21.5	
UTG61823PN / UTG6187PNVDEU	18	34.3	31.8 / 33.0	22.4	24.0	
UTG62028PN / UTG62020PN	20	37.5	31.8 / 35.3	25.6	27.2	
UTG62235PN	22	40.7	31.8	26.5	30.4	
UTG62448PN	24	43.9		31.7	33.5	

For bulk packing (qty 100 pcs) add B at the end of cat. Nr. eg. UTG61412PNB

Cable plug for socket contacts (UTG6- - - -SN)

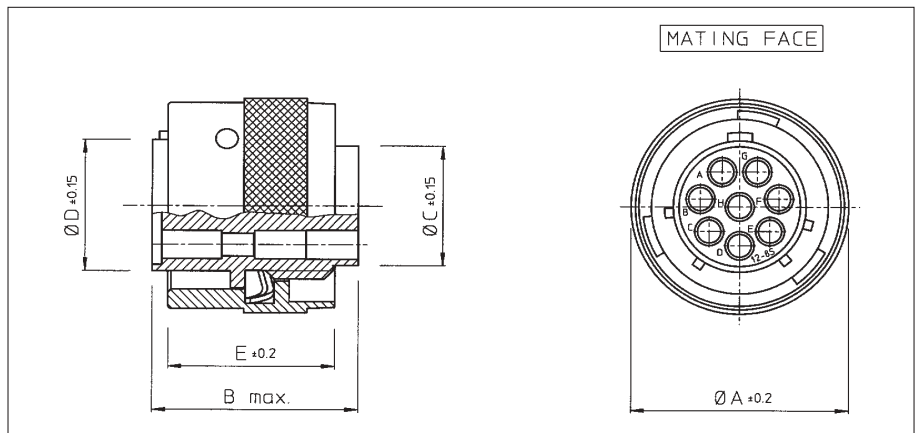

Part number	Shell size	Ø A ±0.2	B max.	Ø C ±0.15	Ø D ±0.15	E ±0.2
UTG6104SN / UTG6103SNVDE	10	21.6	23.9 / 26.75	10.9	12.2	19.1
UTG6128SN	12	24.8	23.9	13.8	15.1	
UTG61412SN	14	28.0		17.0	18.3	
UTG61619SN	16	31.2	19.9	21.5		
UTG61823SN / UTG6187SNVDEU	18	34.3	23.9 / 29.0	22.4	24.0	
UTG62028SN / UTG62020SN	20	37.5	24.9	25.6	27.2	
UTG62235SN	22	40.7		28.5	30.4	
UTG62448SN	24	43.9	26.2	31.7	33.5	

For bulk packing (qty 100 pcs) add B at the end of cat. Nr. eg. UTG61412SNB



Wall mounting receptacle for pin contacts (UTG0- - - -P)

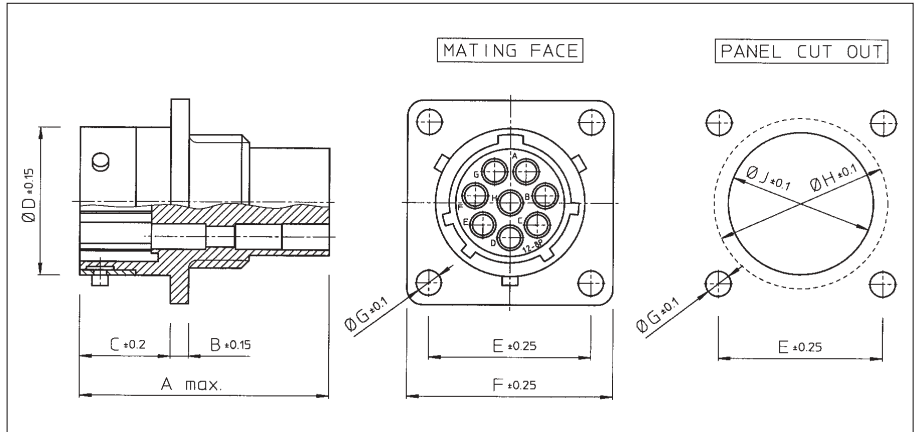

Part number	Shell size	A max.	B ±0.15	C ±0.2	Ø D ±0.15	E ±0.25	F +0.25	Ø G ±0.1	Ø H ±0.1	Ø J ±0.1
UTG0104P / UTG0103PVDE	10	31.7	2.3	11.3	15.0	18.3	23.8	3.2	17.3	15.1
UTG0128P	12				19.0	20.6	26.2		21.8	18.2
UTG01412P	14				22.2	23.0	28.6		25.0	21.4
UTG01619P	16				25.3	24.6	31.0		28.1	24.6
UTG01823P / UTG0187PVDEU	18	31.7/34.0	2.5	11.3/17.9	28.5	27.0	33.3	3.9	31.3	27.8
UTG02028P / UTG02020P	20	33.3/34.3	3.5	14.5	31.7	29.4	36.5		34.5	30.9
UTG02235P	22	33.3		34.9	31.8	39.7	37.7		34.1	
UTG02448P	24	15.3		38.0	34.9	42.9	40.9		37.3	

For waterprotected version add "H" behind "P" e.g. UTG01412PH

For bulk packing (qty 100 pcs) add B at the end of cat. Nr. eg. UTG01412PB

Wall mounting receptacle for socket contacts (UTG0- - - -S)

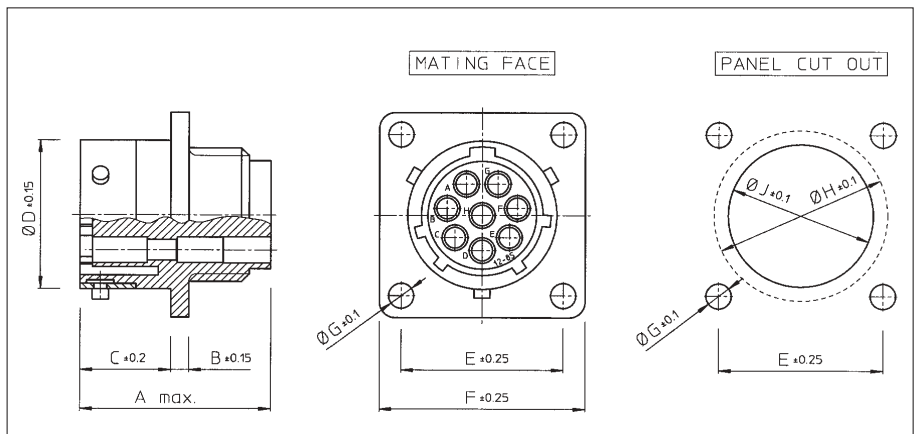

Part number	Shell size	A max.	B ±0.15	C ±0.2	Ø D ±0.15	E ±0.25	F +0.25	Ø G ±0.1	Ø H ±0.1	Ø J ±0.1
UTG0104S / UTG0103SVDE	10	24.3/27.6	2.3	11.3	15.0	18.3	23.8	3.2	17.3	15.1
UTG0128S	12	24.3			19.0	20.6	26.2		21.8	18.2
UTG01412S	14				22.2	23.0	28.6		25.0	21.4
UTG01619S	16				25.3	24.6	31.0		28.1	24.6
UTG01823S / UTG0187SVDEU	18	24.3/30.4	2.5	11.3/17.9	28.5	27.0	33.3	3.9	31.3	27.8
UTG02028S / UTG02020S	20	27.0	3.5	14.5	31.7	29.4	36.5		34.5	30.9
UTG02235S	22	28.0		34.9	31.8	39.7	37.7		34.1	
UTG02448S	24	30.4		15.3	38.0	34.9	42.9		40.9	37.3

For waterprotected version add "H" behind "P" e.g. UTG01412SH

For bulk packing (qty 100 pcs) add B at the end of cat. Nr. eg. UTG01412SB



Free hanging receptacle for pin contacts (UTG1- - - -P)

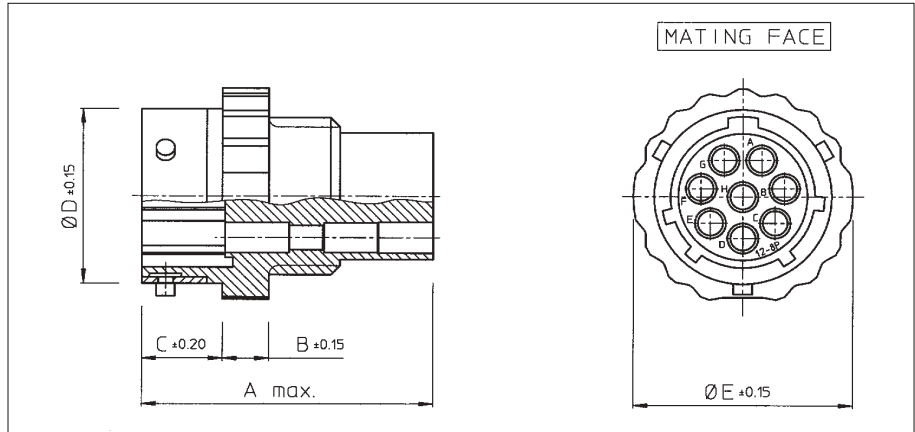

Part number	Shell size	A max.	B ± 0.15	C ± 0.2	$\varnothing D \pm 0.15$	$\varnothing E \pm 0.15$
UTG1104P / UTG1103PVDE	10	31.7	5.0	8.65	15.0	19.5
UTG1128P	12				19.0	23.5
UTG11412P	14				22.2	27.0
UTG11619P	16				25.3	30.0
UTG11823P / UTG1187PVDEU	18	31.7/34.0	5.0	8.65/15.35	28.5	33.0
UTG12028P / UTG12020P	20	33.3/34.3		12.05	31.7	36.5
UTG12235P	22	33.3		34.9	39.5	
UTG12448P	24			13.85	38.0	42.5

For waterprotected version add "H" behind "P" e.g. UTG11412PH

For bulk packing (qty 100 pcs) add B at the end of cat. Nr. eg. UTG11412PB

Free hanging receptacle for socket contacts (UTG1- - - -S)

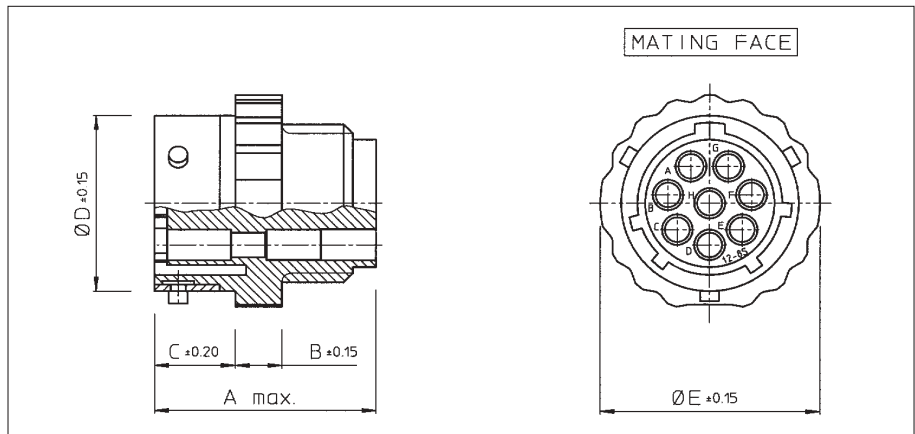

Part number	Shell size	A max.	B ± 0.15	C ± 0.2	$\varnothing D \pm 0.15$	$\varnothing E \pm 0.15$
UTG1104S / UTG1103SVDE	10	24.3/27.6	5.0	8.65	15.0	19.5
UTG1128S	12	24.3			19.0	23.5
UTG11412S	14				22.2	27.0
UTG11619S	16				25.3	30.0
UTG11823S / UTG1187SVDEU	18	24.3/30.4	5.0	8.65/15.35	28.5	33.0
UTG12028S / UTG12020S	20	25.9		12.05	31.7	36.5
UTG12235S	22			34.9	39.5	
UTG12448S	24				13.85	38.0

For waterprotected version add "H" behind "P" e.g. UTG11412SH

For bulk packing (qty 100 pcs) add B at the end of cat. Nr. eg. UTG11412SB



Full plastic circular Trim Trio connector

Description

“UTP” full plastic industrial circular connectors are a range of multiway connectors.

“UTP” provides the complete answer to the need for economical lightweight, robust circular connectors and is unique in offering a plastic bayonet coupling ring incorporating a metal wave spring, which locks with an audible positive “click”. It is available in 8 shell sizes, 10 insert arrangements all intermateable, interchangeable and intermountable with the Trim-Trio “UT0” (full metal) and “UTG” (plastic with metal coupling ring) industrial connector families.



Features and benefits

- Available in 8 shell sizes and 10 insert arrangements incl. 2 VDE versions.
- Available in plug and receptacle versions for both male and female contacts.
- Connectors and accessories are moulded from highly durable glass-filled thermoplastic.
- Flammability rating: UL94-V0.
- Plastic bayonet ring:
 - Vibration proof thermoplast
 - Metal wave spring loaded.
 - Locks with audible positive “click”

Performance characteristics

Operating temperature:	-55°C to +125°C
Insulation resistance:	5000 MΩ min.
Test potential:	2000 VAC
Durability:	250 matings and unmatings.
Degree of protection per DIN 40050: IP65 in mated condition. “H” version used with UTG-PG cable clamp	

Construction

Connector, Bayonet ring and accessories
Gas filled thermoplast UL94-V0
Colour: black
Coupling spring: Spring steel

Contact accommodation

- “UTP” connectors accept Trim-Trio crimp-type removable snap-lock contacts (see contacts section)
- Contacts to be ordered separately.

How to order

Connector family :	UTP	0	14	12	P	H	--	B
	UTP	6	14	12	S		--	B
Body variation:	0 : Wall mounting receptacle 6 : Cable plug							
Shell size:								
Insert arrangement:								
Type of contacts:	P : Pin contacts S : Socket contacts							
Application	No letter : Standard version H : Water protected version (only receptacle)							
Design variation	No letter : Moulded-in contact marking (standard version) Others : Specials versions							
Packing:	No letter: Standard version: Each connector individually packed in plastic bag B: Bulk packing per qty of 100 pcs							



New

Cable plug for pin contacts (UTP6- - - -P)

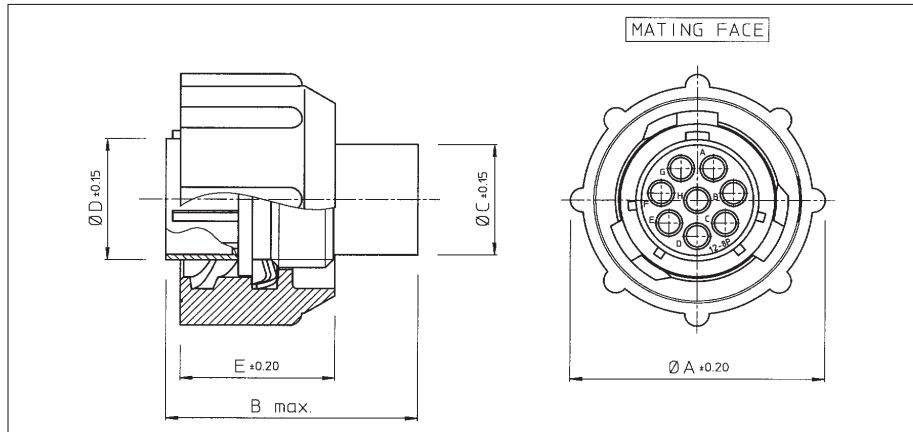

Part number	Shell size	$\varnothing A \pm 0.2$	B max.	$\varnothing C \pm 0.15$	$\varnothing D \pm 0.15$	$\varnothing E \pm 0.2$
UTP6104P / UTP6103PVDE	10	26.7	31.8	10.9	12.2	19.1
UTP6128P	12	31.4		13.8	15.1	
UTP61412P	14	34.5		17.0	18.3	
UTP61619P	16	37.8		19.9	21.5	
UTP61823P / UTP6187PVDEU	18	40.8	31.8 / 33.0	22.4	24.0	
UTP62028P	20	43.9	31.8	25.6	27.2	
UTP62235P	22	47.0		28.5	30.4	
UTP62448P	24	50.1		31.7	33.5	

For bulk packing (qty 100 pcs) add B at the end of cat. Nr. eg. UTP61412PB

Cable plug for socket contacts (UTP6- - - -S)

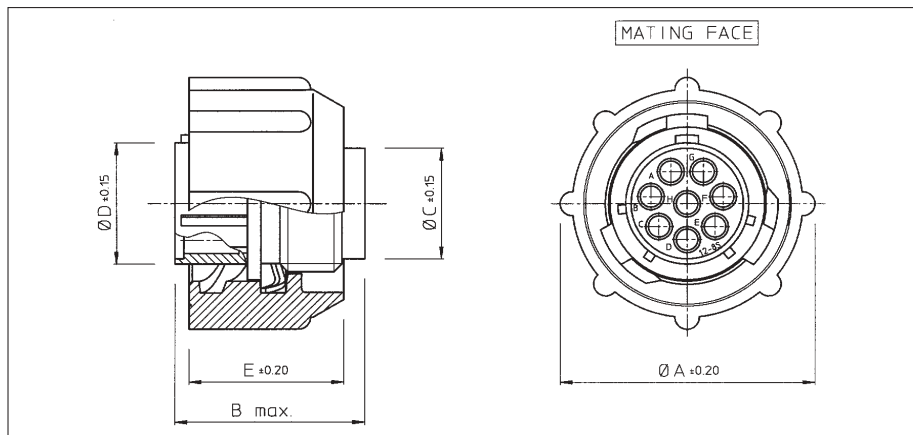

Part number	Shell size	$\varnothing A \pm 0.2$	B max.	$\varnothing C \pm 0.15$	$\varnothing D \pm 0.15$	$\varnothing E \pm 0.2$
UTP6104S / UTP6103SVDE	10	26.7	23.9	10.9	12.2	19.1
UTP6128S	12	31.4		13.8	15.1	
UTP61412S	14	34.5		17.0	18.3	
UTP61619S	16	37.8		19.9	21.5	
UTP61823S / UTP6187SVDEU	18	40.8	23.9 / 29.0	22.4	24.0	
UTP62028S	20	43.9	24.9	25.6	27.2	
UTP62235S	22	47.0		28.5	30.4	
UTP62448S	24	50.1		26.2	33.5	

For bulk packing (qty 100 pcs) add B at the end of cat. Nr. eg. UTP61412SB



New

Wall mounting receptacle for pin contacts (UTP0- - - -P)

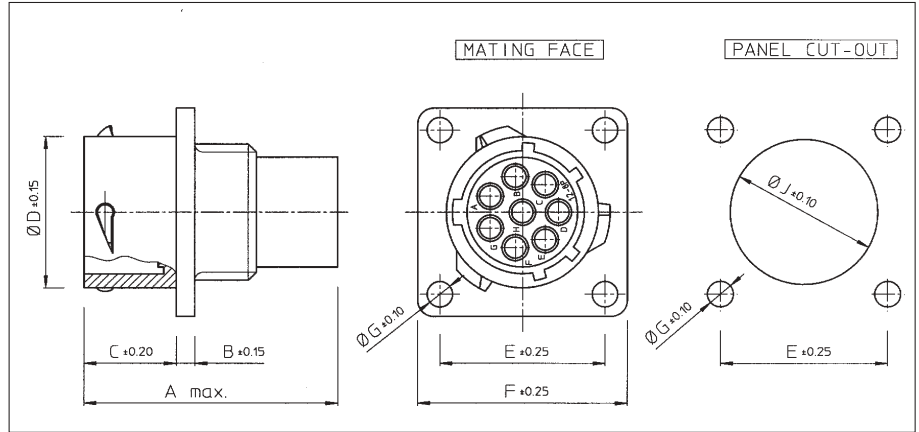

Part number	Shell size	A max.	B ± 0.15	C ± 0.2	$\varnothing D \pm 0.15$	E ± 0.25	F ± 0.25	$\varnothing G \pm 0.1$	$\varnothing H \pm 0.1$	$\varnothing J \pm 0.1$
UTP0104P / UTP0103PVDE	10	31.7	2.3	11.3	15.0	18.3	23.8	3.2	15.1	
UTP0128P	12				19.0	20.6	26.2		18.2	
UTP01412P	14				22.2	23.0	28.6		21.4	
UTP01619P	16				25.3	24.6	31.0		24.6	
UTP01823P / UTP0187PVDEU	18	31.7/34.0	2.5	11.3/17.9	28.5	27.0	33.3	3.2	27.8	
UTP02028P	20	33.3	3.5	14.5	31.7	29.4	36.5	3.9	30.9	
UTP02235P	22			34.9	31.8	39.7	34.1			
UTP02448P	24			15.3	38.0	34.9	42.9		37.3	

For waterprotected version add "H" behind "P" e.g. UTP01412PH

For bulk packing (qty 100 pcs) add B at the end of cat. Nr. eg. UTP01412PB

Wall mounting receptacle for socket contacts (UTP0- - - -S)

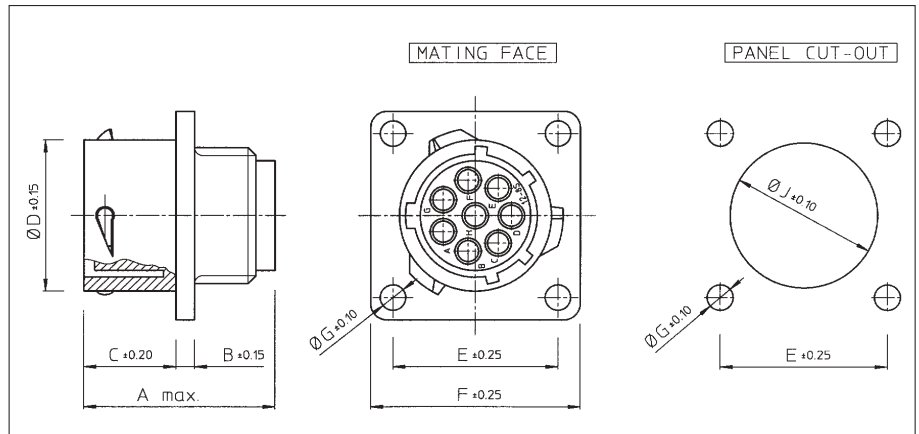

Part number	Shell size	A max.	B ± 0.15	C ± 0.2	$\varnothing D \pm 0.15$	E ± 0.25	F ± 0.25	$\varnothing G \pm 0.1$	$\varnothing H \pm 0.1$	$\varnothing J \pm 0.1$
UTP0104S / UTP0103SVDE	10	24.3/27.6	2.3	11.3	15.0	18.3	23.8	3.2	15.1	
UTP0128S	12	24.3			19.0	20.6	26.2		18.2	
UTP01412S	14				22.2	23.0	28.6		21.4	
UTP01619S	16				25.3	24.6	31.0		24.6	
UTP01823S / UTP0187SVDEU	18	24.3/30.4	2.5	11.3/19.7	28.5	27.0	33.3	3.2	27.8	
UTP02028S	20	27.0	3.5	14.5	31.7	29.4	36.5	3.9	30.9	
UTP02235S	22	28.0		34.9	31.8	39.7	34.1			
UTP02448S	24	30.4		15.3	38.0	34.9	42.9		37.3	

For waterprotected version add "H" behind "P" e.g. UTP01412SH

For bulk packing (qty 100 pcs) add B at the end of cat. Nr. eg. UTP01412SB



New

Shielded circular TRIM TRIO connectors UT0 and UTGS

Description

With the increasing coverage of the electromagnetic spectra and the constantly increasing use of electronic hardware, the need for control on electronic equipment to operate in electromagnetically noisier environments and greater control is one of the main issues.

More and more electronic equipment will be required to meet an EMC (Electro Magnetic Compatibility) specification which controls the level of EM emissions being upset by interfering RF (Radio Frequency) and EM (Electro Magnetic) fields.

A full solution to the problem consists in the consideration of each and every aspect within a design, starting at the board level and working outwards through the connector to the enclosure and then on to the power supply and signal cabling. As a result, UT0 and UTGS are available with shielded backshells including a “two conical ferrule shielding system”.

Shielding effectiveness is a functional method to characterise the shield leakage, since it offers us the relation between the measured power progression from shielding leakage and the reference power delivered to the test-cell

Test set-up

The measurements are performed with the triaxial setup.

The connectors are embedded in a rectangular testcell (see picture)

For the circular connectors an inner conductor is constructed to obtain a 50(coaxial transmission line, to which a power level Pin is delivered. The shield of the connector and the walls from the triaxial cell form the second coaxial transmission line. The output power

Pout at one end of the short-circuited second transmission line is measured with a spectrum analyser. From the average of these quantities, the shielding effectiveness is calculated (see formula and resulting chart).

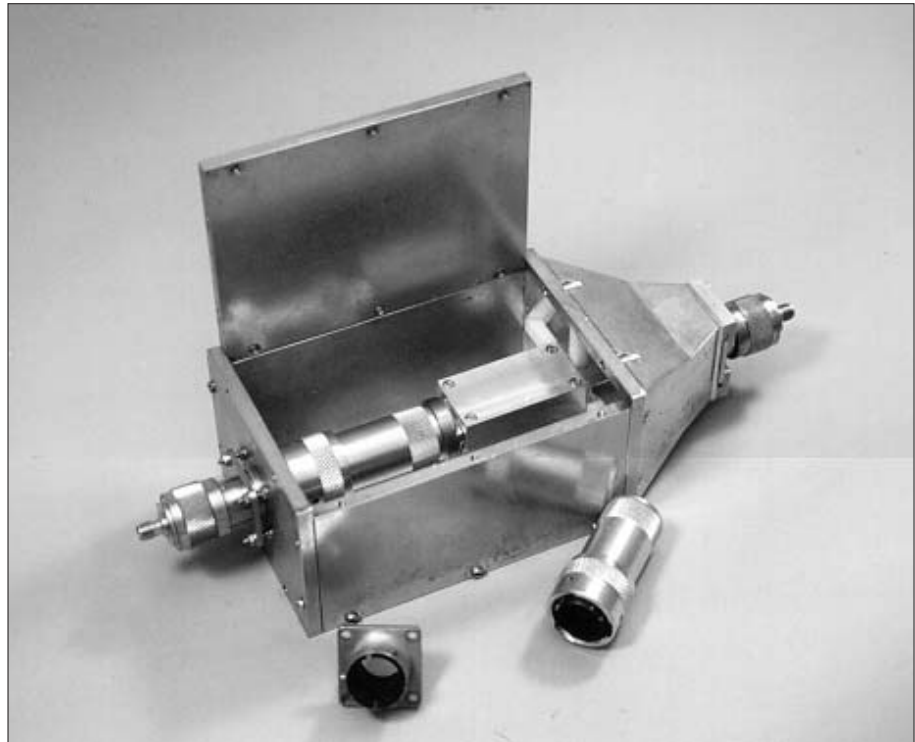

Formula: Shielding effectiveness in dB

$$S.E. (dB) = 10 \times \text{Log} \left(\frac{P_{\text{Leakage}}}{P_{\text{Ref.}}} \right)$$

Shielding effectiveness chart for UT0 and UTGS

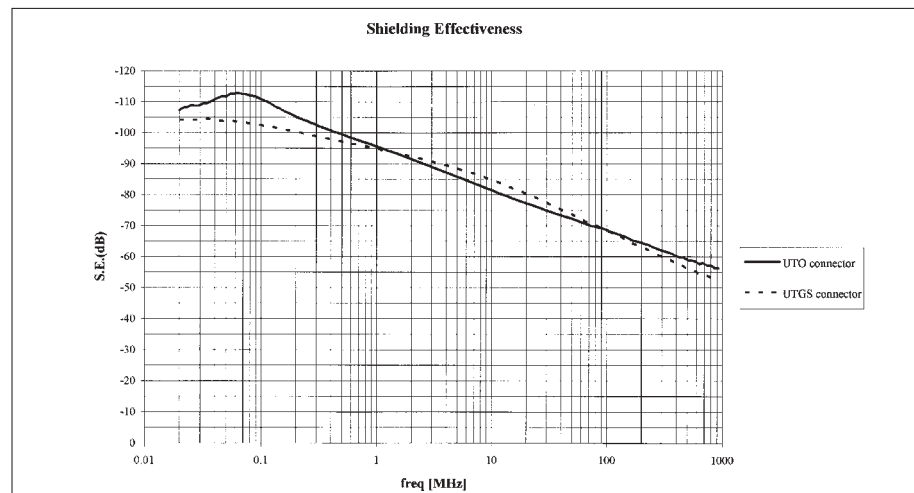

Shielded connectors



New

How to assemble shielded connectors ...

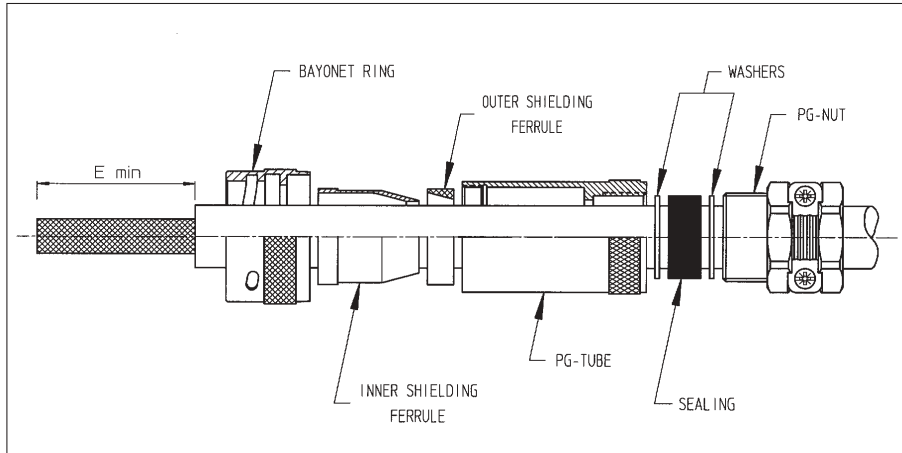

SIZE-NR.	POS.	DIM E
10	- 4	22.3
12	- 8	22.3
14	- 12	26.2
16	- 19	28.1
18	- 23	31.7
20	- 28	35.3
22	- 35	40.5
24	- 48	44.4

Put all parts over the cable, including the coupling ring, as shown on the picture. Strip the outer jacket with the dimensions given in the table.

Recommended cable strip dimensions

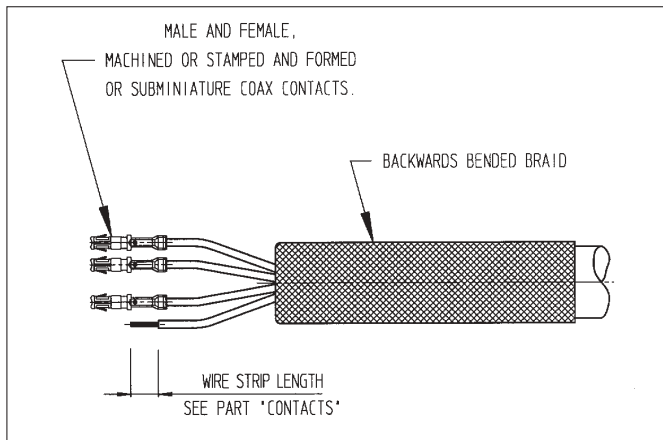

Bend the braid backwards over the cable jacket. Strip the wires (refer to contact section). Crimp the contacts.

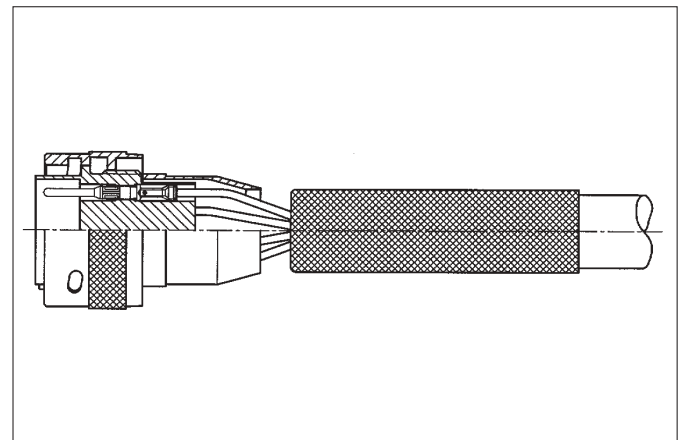

Insert contact into connector. Slide inner shielding ferrule over the connector.

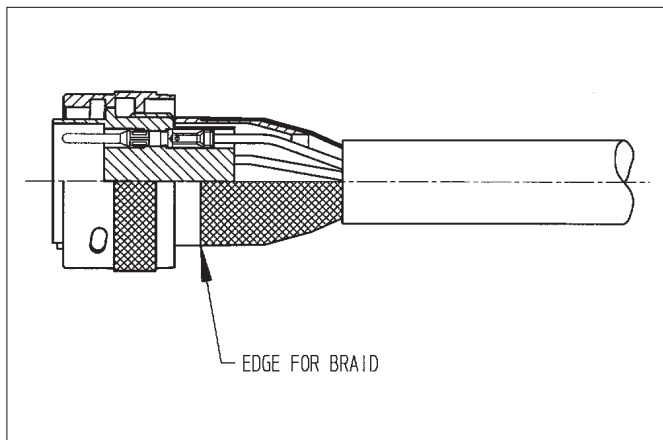

Bend the braid back over the conical part of the inner shielding ferrule. Cut the shield so that it does not pass the front edge as shown

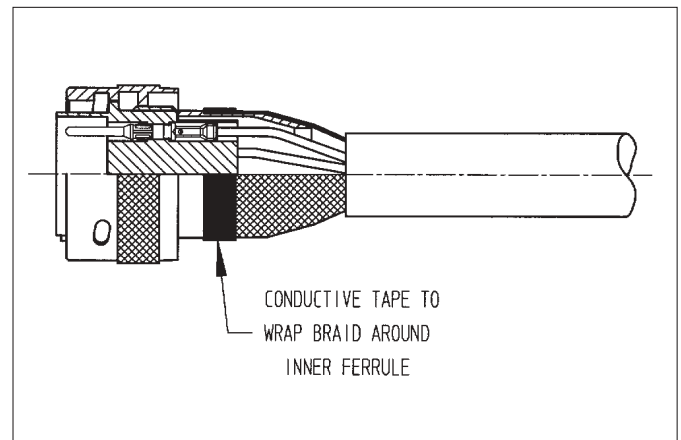

Wrap shielding around inner shielding ferrule using a conductive tape. Make sure that the braid is wrapped equally around the ferrule to avoid misalignment when assembled.

Shielded connectors



New

How to assemble shielded connectors ... (cont.)

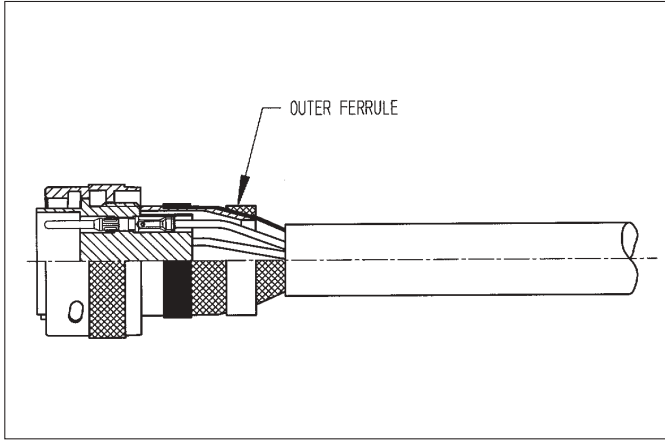

Slide coupling ring forwards over the connector.
Slide outer shielding ferrule over the shield.
Push the cable a little forward to avoid stress on wires, contact and braid after tightening the PG-tube.

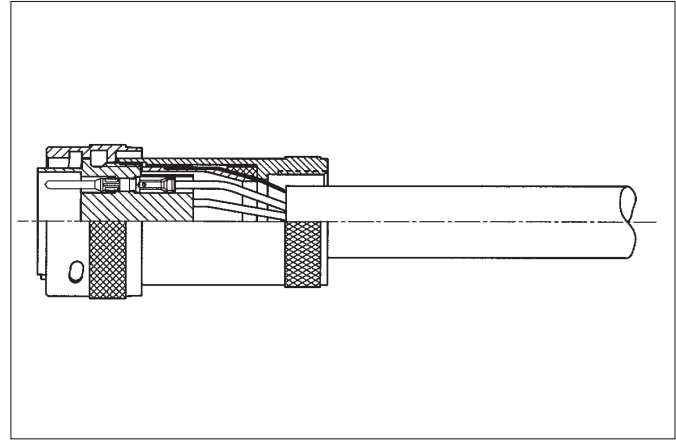

Screw the PG-tube onto the connector using a strap wrench.
Put the plug in an empty receptacle and fix the receptacle in a bench.
Tighten the PG-tube with the recommended torque moments given in table and prevent the cable of twisting.
For Strap wrench and torque meters cosult factory.

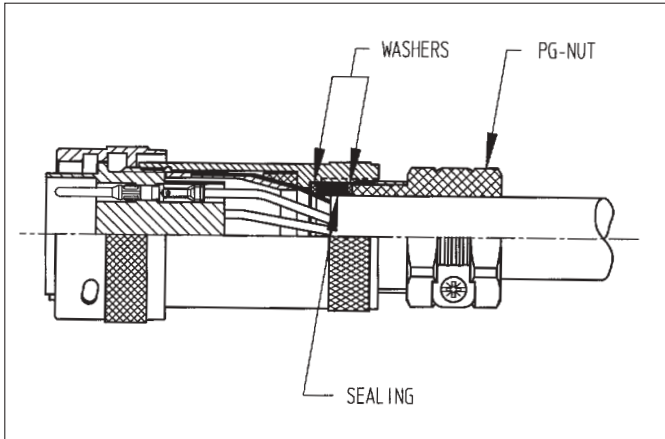

Screw the sealing and the PG-nut into the PG-tube to achieve sealing.
Tighten up cable clamp.
Note: Tightening the PG-tube with its PG-nut and sealing might twist the braid.

SIZE-NR . POS .	TORQUE PG-TUBE
10 - 4	4 Nm max .
12 - 8	6 Nm max .
14 - 12	10 Nm max .
16 - 19	10 Nm max .
18 - 23	10 Nm max .
20 - 28	15 Nm max .
22 - 35	15 Nm max .
24 - 48	15 Nm max .

Recommended torque moments to tighten PG-tube onto connector.

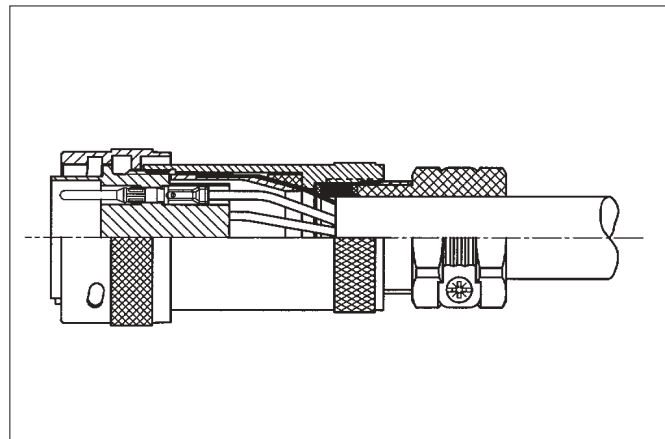

Shielded connector in assembled condition.



New

Metallised plastic connector for EMC requirements

Description

“UTGS” Shielded Bantam are a range of industrial circular connectors suitable for EMC requirements.

It is a range of multiway connectors available in 8 shell sizes and 13 insert arrangements all intermateable, interchangeable and intermountable with the Trim-Trio “UT0” metal connector families. Finding its origin in the “UTG” range, “UTGS” keeps the metal locking system, whilst the connectors are selectively metallised.

This together with a new shielded backshell offers a competent, reliable, user friendly and cost effective solution .

Features and benefits

- Suitable for EMC requirements.
- Shielded backshell is independent from the cable diameter and its shielding.
- Available in 8 shell sizes and 13 insert arrangements incl. 3 VDE versions and one power version.
- Available in plug and receptacle versions for both male and female contacts.
- Connectors are moulded from highly durable glass-filled thermoplastic. Selectively nickel plated
- Flammability rating: UL94-V0.
- Metal bayonet ring:
 - Metal wave spring loaded.
 - Locks with audible positive “click”
 - Assures 500 matings and unmatings



Performance characteristics

Operating temperature:	-55°C to +125°C
Insulation resistance:	5000 MΩ min.
Test potential:	2000 VAC
Durability:	500 matings and unmatings.
Vibration resistance:	Per MIL-STD202 method 204
Thermal shock:	Per MIL-STD202 method 207
Corrosion:	Salt spray per MIL-STD 202 method 101
Shielding effectiveness: 95 dB at 1 Mhz (See shielded connectors section)	
Degree of protection per DIN 40050: IP65 in mated condition. “H” version	

Construction

Connector body	Glass filled thermoplast UL94-V0
	Colour: black
	Selectively nickel plated
Coupling ring:	Nickel plated brass
Tri-lock pins:	Stainless steel
Coupling spring:	Spring steel
Shielded backshell :	Nickel plated Aluminium alloy.

Contact accommodation

- “UTGS” connectors accept Trim-Trio crimp-type removable snap-lock contacts (see contact section)
- Contacts to be ordered seperately.

How to order

Connector family:	UTGS	0	PG	14	12	P	H	-	N	B
	UTGS	6		14	12	S		-	N	-
Body variation:	0 : Wall mounting receptacle 6 : Cable plug 1 : Free hanging receptacle									
Shielded backshell:										
Shell size:										
Insert arrangement:										
Type of contacts:	P : Pin contacts S : Socket contacts									
Application:	No letter : Standard version H : Water protected version (only receptacle)									
Design variation:	No letter : Moulded-in contact marking (standard version) others : Special versions									
Plating:	N : Nickel plated									
Packing:	No letter : Standard version: Each connector individually packed in plastic bag B : Bulk packing per qty of 100 pcs									



New

Shielded cable plug for pin contacts (UTGS6PG- - - -PN)

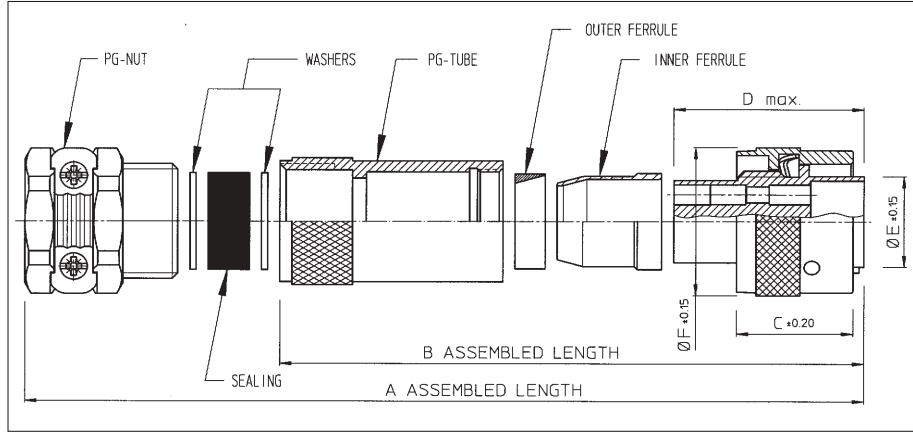

Part number	Shell size	A	B	C ±0.2	D Max.	Ø E ±0.15	F ±0.15	Max cable Ø
UTGS6PG104PN / UTGS6PG103PNVDE	10	70/74.1	52.2/56.3	19.1	31.8	12.2	21.6	11.0
UTGS6PG128PN	12	74	53.2			15.1	24.8	13.5
UTGS6PG1412PN	14	81	58.2			18.3	28.0	14.5
UTGS6PG1619PN	16	84	61.2		21.5	31.2	16.5	
UTGS6PG1823PN / UTGS6PG187PNVDEU	18	88/94.4	65.2/71.6		31.8/33.0	24.0	34.3	16.5
UTGS6PG2028PN / UTGS6PG2020PN	20	101	70.9		31.8/35.3	27.2	37.5	22.0
UTGS6PG2235PN	22	107	76.9		31.8	30.4	40.7	22.0
UTGS6PG2448PN	24	120	81.9			33.5	43.9	29.5

- For ass'y procedure see shielded connectors section
 For bulk packing (qty 100 pcs) add B at the end of cat. Nr. eg. UTGS6PG1412PNB

Shielded cable plug for socket contacts (UTGS6PG- - - -SN)

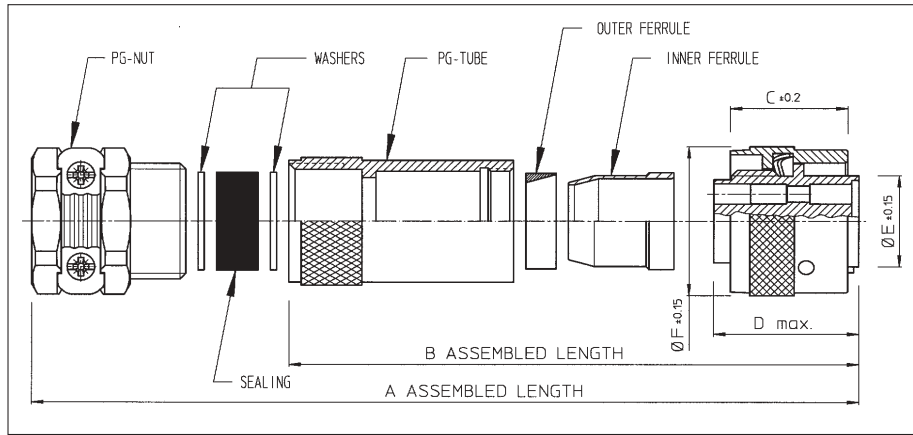

Part number	Shell size	A	B	C ±0.2	D Max.	Ø E ±0.15	F ±0.15	Max cable Ø	
UTGS6PG104SN / UTGS6PG103SNVDE	10	70 / 74.1	52.2 / 56.3	19.1	23.9/26.8	12.2	21.6	11.0	
UTGS6PG128SN	12	74	53.2		23.9	23.9	15.1	24.8	13.5
UTGS6PG1412SN	14	81	58.2				18.3	28.0	14.5
UTGS6PG1619SN	16	84	61.2				21.5	31.2	16.5
UTGS6PG1823SN / UTGS6PG187SNVDEU	18	88 / 94.4	65.2 / 71.6		23.9/29.0	24.0	34.3	16.5	
UTGS6PG2028SN / UTGS6PG2020SN	20	101	70.9		24.9	27.2	37.5	22.0	
UTGS6PG2235SN	22	107	76.9		26.2	30.4	40.7	22.0	
UTGS6PG2448SN	24	120	81.9			33.5	43.9	29.5	

- For ass'y procedure see shielded connectors section
 For bulk packing (qty 100 pcs) add B at the end of cat. Nr. eg. UTGS6PG1412SNB



New

Shielded wall mounting receptacle for pin contacts (UTGS0- - - -PN)

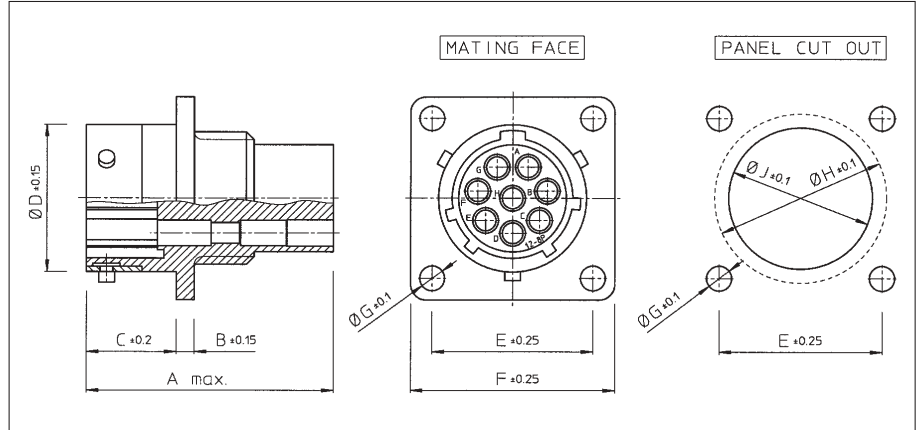

Part number	Shell size	A max.	B ±0.15	C ±0.2	Ø D ±0.15	E ±0.25	F ±0.25	Ø G ±0.1	Ø H ±0.1	Ø J ±0.1
UTGS0104PN / UTGS0103PNVDE	10	31.7	2.3	11.3	15.0	18.3	23.8	3.2	17.3	15.1
UTGS0128PN	12				19.0	20.6	26.2		21.8	18.2
UTGS01412PN	14				22.2	23.0	28.6		25.0	21.4
UTGS01619PN	16				25.3	24.6	31.0		28.1	24.6
UTGS01823PN / UTGS0187PNVDEU	18	31.7/34.0	2.5	11.3/17.9	28.5	27.0	33.3		31.3	27.8
UTGS02028PN / UTGS02020PN	20	33.3/34.3	3.5	14.5	31.7	29.4	36.5		34.5	30.9
UTGS02235PN	22	33.3		34.9	31.8	39.7	37.7		34.1	
UTGS02448PN	24	15.3		38.0	34.9	42.9	3.9		40.9	37.3

For waterprotected version add "H" behind "P" e.g. UTGS01412PHN
 For bulk packing (qty 100 pcs) add B at the end of cat. Nr. eg. UTGS01412PNB

Shielded wall mounting receptacle for socket contacts (UTGS0- - - -SN)

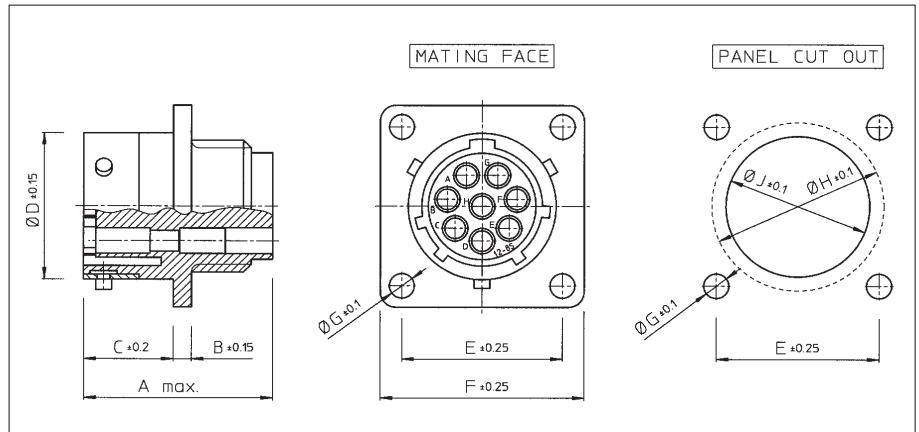

Part number	Shell size	A max.	B ±0.15	C ±0.2	Ø D ±0.15	E ±0.25	F ±0.25	Ø G ±0.1	Ø H ±0.1	Ø J ±0.1
UTGS0104SN / UTGS0103SNVDE	10	24.3/27.6	2.3	11.3	15.0	18.3	23.8	3.2	17.3	15.1
UTGS0128SN	12	24.3			19.0	20.6	26.2		21.8	18.2
UTGS01412SN	14				22.2	23.0	28.6		25.0	21.4
UTGS01619SN	16				25.3	24.6	31.0		28.1	24.6
UTGS01823SN / UTGS0187SNVDEU	18	24.3/30.4	2.5	11.3/17.9	28.5	27.0	33.3		31.3	27.8
UTGS02028SN / UTGS02020SN	20	27.0	3.5	14.5	31.7	29.4	36.5		34.5	30.9
UTGS02235SN	22	28.0		34.9	31.8	39.7	37.7		34.1	
UTGS02448SN	24	30.4		15.3	38.0	34.9	42.9		3.9	40.9

For waterprotected version add "H" behind "P" e.g. UTGS01412SHN
 For bulk packing (qty 100 pcs) add B at the end of cat. Nr. eg. UTGS01412SNB



Shielded free hanging receptacle for pin contacts (UTGS1PG- - -PN)

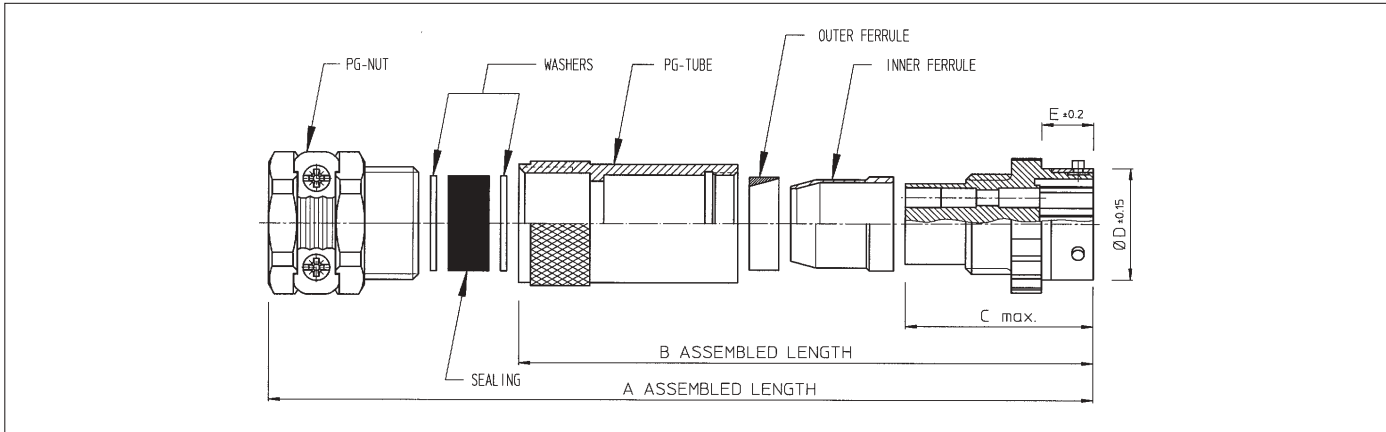

Part number	Shell size	A	B	C max	D ± 0.15	$\varnothing E \pm 0.2$
UTGS1PG104PN / UTGS1PG103PNVDE	10	70 / 74.1	52.2 / 56.3	31.7	15.0	8.65
UTGS1PG128PN	12	74	53.2		19.0	
UTGS1PG1412PN	14	81	58.2		22.2	
UTGS1PG1619PN	16	84	61.2		25.3	
UTGS1PG1823PN / UTGS1PG187PNVDEU	18	88 / 94.4	65.2 / 71.6	31.7 / 34.0	28.5	8.65 / 15.35
UTGS1PG2028PN / UTGS1PG2020PN	20	101	70.9	33.3	31.7	12.05
UTGS1PG2235PN	22	107	76.9		34.9	
UTGS1PG2448PN	24	120	81.9		38.0	

For waterprotected version add "H" behind "P" e.g. UTGS1PG1412PHN
 For bulk packing (qty 100 pcs) add B at the end of cat. Nr. eg. UTGS1PG1412PNB

Shielded free hanging receptacle for socket contacts (UTGS1PG- - -SN)

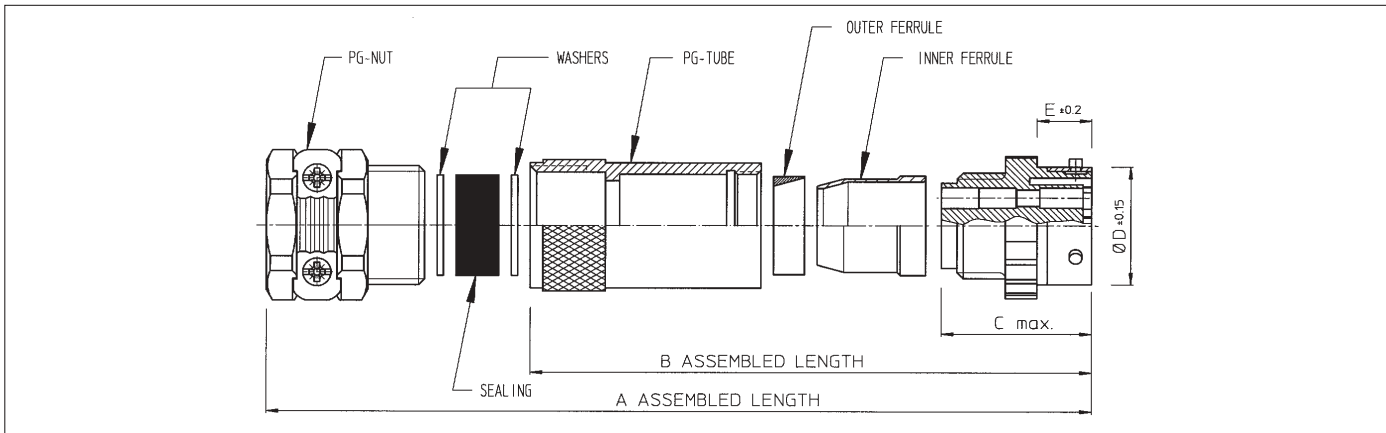

Part number	Shell size	A	B	C max	D ± 0.15	$\varnothing E \pm 0.2$
UTGS1PG104SN / UTGS1PG103SNVDE	10	70 / 74.1	52.2 / 56.3	24.3 / 27.6	15.0	8.65
UTGS1PG128SN	12	74	53.2	24.3	19.0	
UTGS1PG1412SN	14	81	58.2		22.2	
UTGS1PG1619SN	16	84	61.2		25.3	
UTGS1PG1823SN / UTGS1PG187SNVDEU	18	88 / 94.4	65.2 / 71.6	24.3 / 30.4	28.5	8.65 / 15.35
UTGS1PG2028SN / UTGS1PG2020SN	20	101	70.9	25.9	31.7	12.05
UTGS1PG2235SN	22	107	76.9		34.9	
UTGS1PG2448SN	24	120	81.9		38.0	

For waterprotected version add "H" behind "P" e.g. UTGS1PG1412SHN
 For bulk packing (qty 100 pcs) add B at the end of cat. Nr. eg. UTGS1PG1412SNB



New

TRIM TRIO special circular connectors for:

- Mixed power / signal
- Boardmount applications

Description

Based upon design-in projects, this range of special connectors is an extension of the long established and popular TRIM TRIO circular connector series, but with the advantage of offering a number of additional features.

Features and benefits

TRIM TRIO connectors suitable for mixed power / signal application.
 TRIM TRIO connectors with preloaded stamped and formed contacts for boardmount application
 Design-in flexibility of TRIM TRIO



UTG size 24-7 with mixed power / signal contacts.

Description

UTG size 24-7 is a standard shell size 24 connector with a modified insert arrangement to accept 7 power contacts of 3.6mm and 2 TRIM TRIO signal contacts. The power contacts are suitable for currents up to 44 Amps. The central contact cavity is advanced moulded for grounding purposes. UTG size 24-7 is VDE 0110 group C - 660V approved.

Typical performance characteristics

VDE 0110 Group C - 660 V approved.
 Central power cavity is advanced for grounding purposes.
 For further characteristics refer to UTG series.

Construction

Refer to UTG series.

Power contacts 3.6mm for up to 44 Amps

Power contacts of 3.6mm are available as standard contacts from the 8P/8PM series. Contacts are for AWG 10, 12 and 14. For all further information such as references, plating, crimp tooling and extraction tooling refer to the 8P / 8GN catalog.

TRIM TRIO size 16 signal contacts

Trim-Trio crimp-type removable snap-lock contacts (refer to TRIM TRIO contacts section)

- Contacts to be ordered separately

UTG size 18-7 with mixed power / signal contacts.

Description

UTG size 18-7 is a standard shell size 18 connector with a modified insert arrangement to accept 2 power contacts of 2.4mm and 5 TRIM TRIO signal contacts. The power contacts are suitable up to 26 Amps and the housings are moulded to obtain 2 mating levels. UTG size 18-7 is per VDE 0110 group C - 380V

Typical performance characteristics

Per VDE 0110 Group C - 380 V.
 2 mating levels.
 For further characteristics refer to UTG series.

Construction

Refer to UTG series.

Power contacts 2.4mm for up to 26 Amps

Power contacts of 2.4mm are available as standard contacts from the 8P/8PM series. Contacts are for AWG 26 up to AWG 14. For all further information such as references, plating, crimp tooling and extraction tooling refer to the 8P / 8GN catalog.

TRIM TRIO size 16 signal contacts

Trim-Trio crimp-type removable snap-lock contacts (refer to TRIM TRIO contacts section)

- Contacts to be ordered separately

UTP7 size 12-8 receptacle for boardmount applications

Description

UTP7 size 12-8 is a receptacle with a central bulkhead instead of the standard square flange with 4 mounting holes. This central bulkhead receptacle is suitable for rear panel mounting and is preassembled with size 16 stamped and formed dipsolder contacts. The receptacle is standard supplied with a ferrite ring at the back of the connector for EMC regulations.

Typical performance characteristics

Ferrite ring at the back of the connector for EMC regulations.
 IP67 in mated conditions.
 For further characteristics refer to UTP series.

Construction

Refer to UTP series.

Performance characteristics for size 16 stamped and formed dipsolder contacts

Current rating 5 Amps
 Contact resistance 6 m Ω
 Plating: 0.4µ Au min in contact area, SnPb on solder tail.

- For receptacle without ferrite ring, right-angle solder tails or other plating specifications, consult factory



New

UTG size 24-7 with mixed power / signal contacts

Cable plug connector for pin contacts. Part number: UTG6247PN

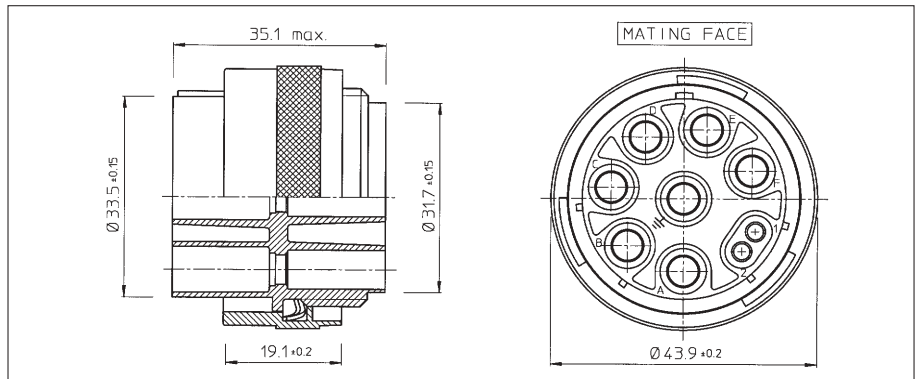

Cable plug connector for socket contacts. Part number: UTG6247SN

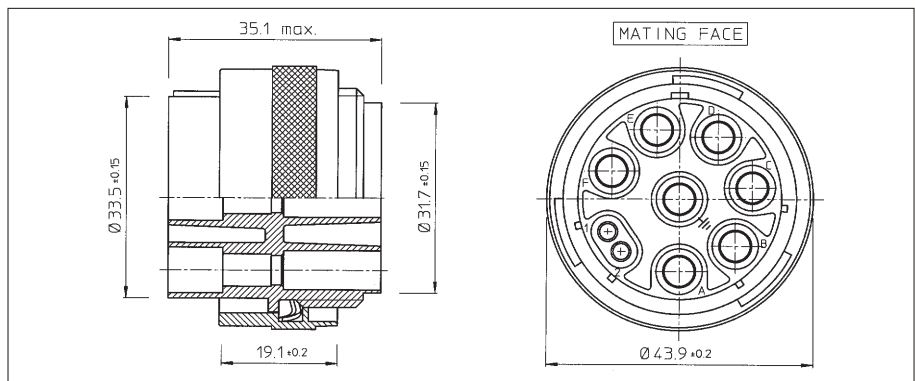

Panel mount receptacle for pin contacts. Part number: UTG0247P

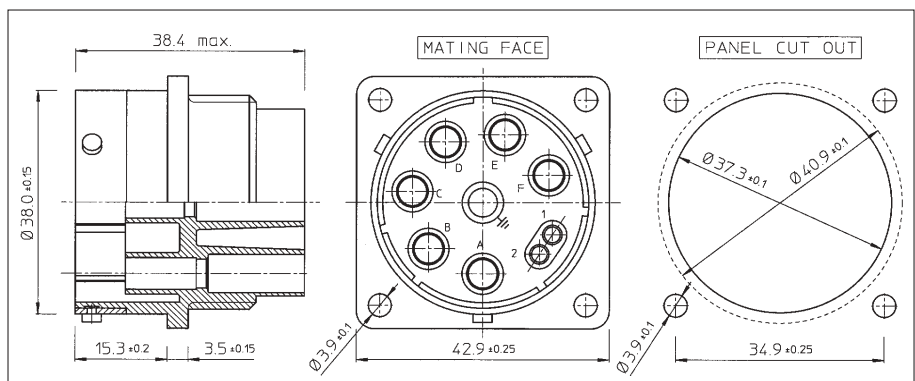

Panel mount receptacle for socket contacts. Part number: UTG0247S

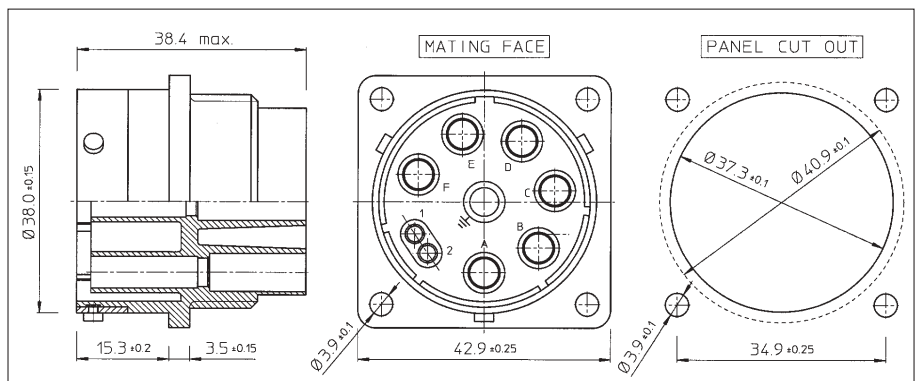



New

UTG size 18-7 with mixed power / signal contacts

Cable plug connector for pin contacts. Part number: UTG6187PNVDE34

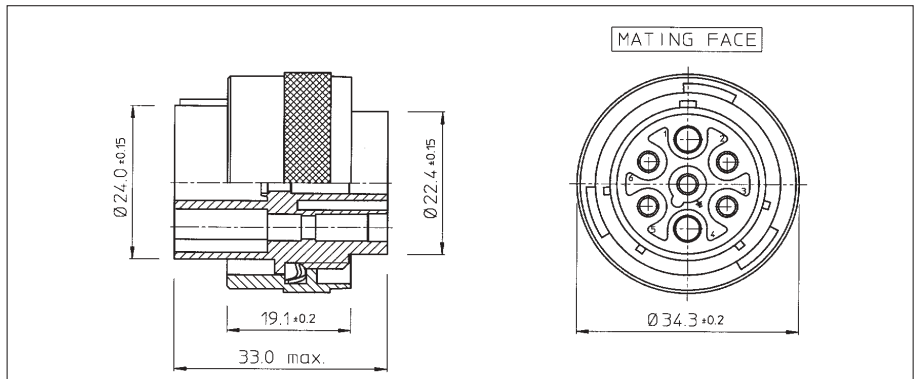

Cable plug connector for socket contacts. Part number: UTG6187SNVDE34

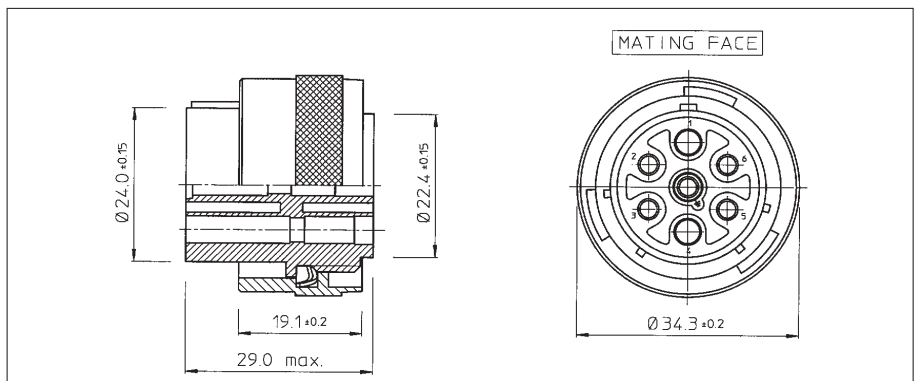

Panel mount receptacle for pin contacts. Part number: UTG0187PVDE34

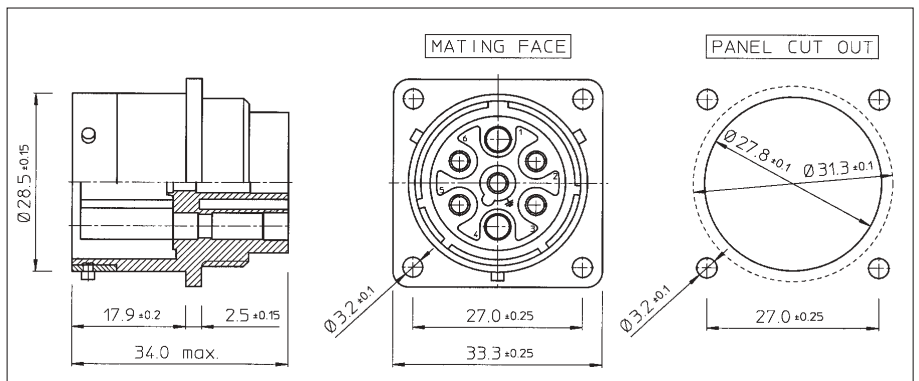

Panel mount receptacle for socket contacts. Part number: UTG0187SVDE34

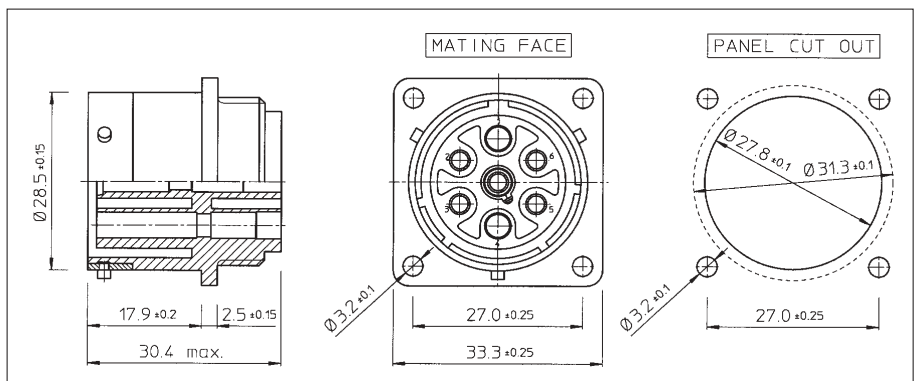



New

UTP7 size 12-8 receptacle for boardmount applications

Bulkhead panelmount receptacle with straight stamped and formed male dipsolder contacts.

Part Number: UTP7128PHSE30K9

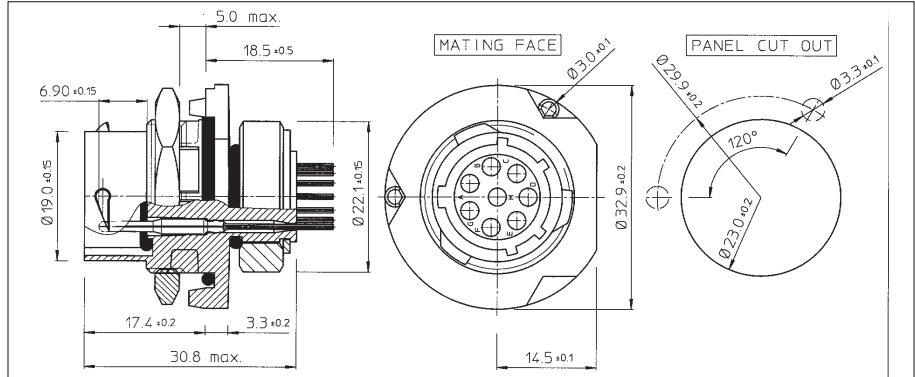

Bulkhead panelmount receptacle with right angle stamped and formed male dipsolder contacts.

Part Number: Consult factory

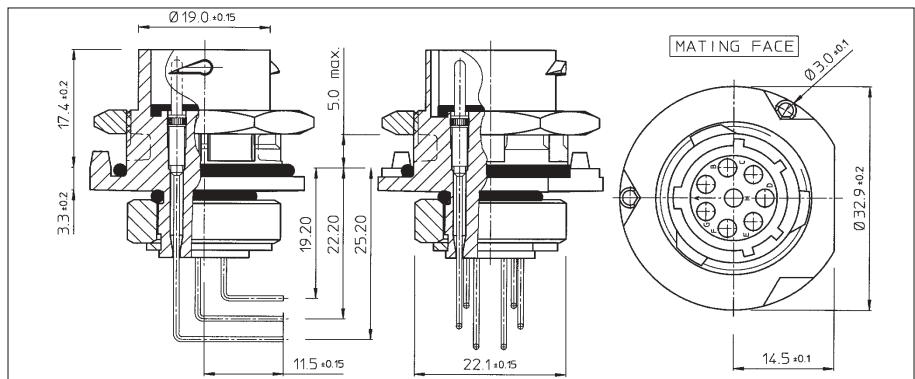



Plastic high density connector with metal coupling

Intermateable with MIL-C-26482 VG-95328 62GB

Description

“UTGW” SEALOK industrial circular connectors are a range of multiway connectors, using N°20 SM-W/SC-W SEALOK contacts with a pin diameter of .040” (1.0mm). This high density connector provides the complete answer to the need for lightweight, robust and economical circular connectors intermateable and intermountable with MIL-C-26482 Series I. 62GB and VG-95328 connectors.



Features and benefits

- Available in 7 shell sizes and 7 insert arrangements.
- Intermateable with MIL-C-26482 series I, 62GB and VG-95328 connectors.
- Plastic connector with metal coupling system.
- Available in cable plug, wall mounting receptacle and free hanging receptacle versions for both male and female contacts.
- Connectors and accessories are moulded from highly durable glass-filled thermoplastic.
- Flammability rating: UL94-V0.
- Bayonet ring:
 - Metal wave spring loaded.
 - Locks with audible positive “click”
- Interfacial seal on pin mating face for the ultimate in environmental protection.
- Interfacial seals have silkscreened cavity marking.

Performance characteristics

Operating temperature:	-55°C to +125°C
Insulation resistance:	5000 MΩ min.
Test potential:	2000 V RMS
Durability:	500 matings and unmatings.
Vibration resistance:	Per MIL-STD1344A Method 2004, Condition III
Thermal shock:	Per MIL-STD1344A Method 2005, Condition A
Salt spray:	Per MIL-STD1344A Method 1001, 48 hrs (mated)
Degree of protection per DIN 40050: IP67 in mated condition used with UTG-ST + UTG-PG cable clamp	

Construction

Connector body	Glass filled thermoplast UL94-V0
	Colour: black
Interfacial seal:	Neoprene rubber
Coupling ring:	Nickel plated brass
Tri-lock pins:	Stainless steel
Coupling spring:	Spring steel

Contact accommodation

- “UTGW” connectors only accept SEALOK crimp type removable snap-lock SM-W / SC-W contacts (see contacts section)
- Contacts to be ordered seperately.

How to order

Connector family	UTGW	0	14	19	P	1	B
	UTGW	6	14	19	S	1	B
Body variation:	0 : Wall mounting receptacle 6 : Cable plug 1 : Free hanging receptacle						
Shell size:							
Insert arrangements:							
Type of contacts:	P : Pin contacts S : Socket contacts						
Design variation:	1 : Interfacial sealing						
Packing:	No letter: Standard version: Each connector individually packed in plastic bag B: Bulk packing per qty of 100 pcs						



New

Cable plug for pin contacts (UTGW6- - - -P1)

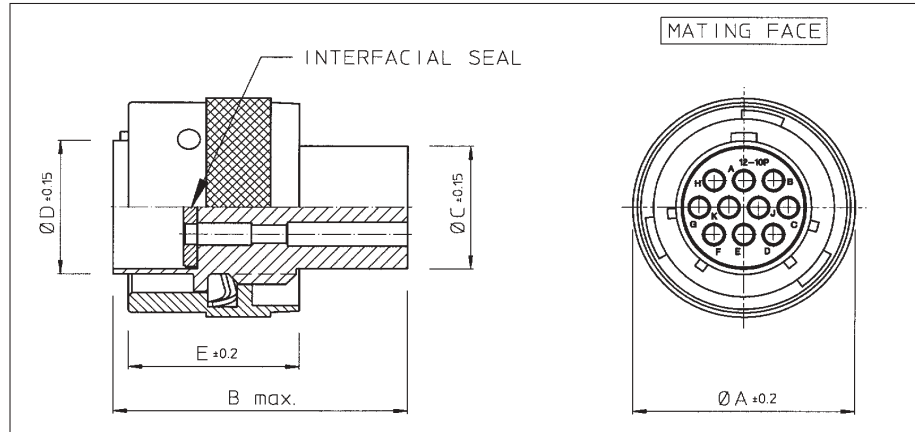

Part number	Shell size	$\varnothing A \pm 0.2$	B Max.	$\varnothing C \pm 0.15$	$\varnothing D \pm 0.15$	E ± 0.2
UTGW6106P1	10	21.6	31.8	10.9	12.2	19.1
UTGW61210P1	12	24.8		13.8	15.1	
UTGW61419P1	14	28.0		17.0	18.3	
UTGW61626P1	16	31.2		19.9	21.5	
UTGW62041P1	20	37.5		25.6	27.2	
UTGW62255P1	22	40.7		26.5	30.4	
UTGW62461P1	24	43.9		31.7	33.5	

For bulk packing (qty 100 pcs) add B at the end of cat. Nr. eg. UTGW61419P1B

Cable plug for socket contacts (UTGW6- - - -S1)

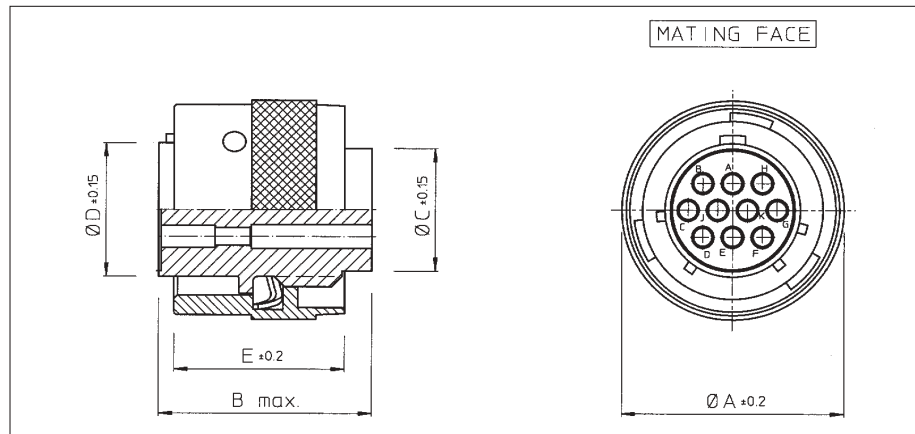

Part number	Shell size	$\varnothing A \pm 0.2$	B Max.	$\varnothing C \pm 0.15$	$\varnothing D \pm 0.15$	E ± 0.2	
UTGW6106S1	10	21.6	23.7	10.9	12.2	19.1	
UTGW61210S1	12	24.8		13.8	15.1		
UTGW61419S1	14	28.0		17.0	18.3		
UTGW61626S1	16	31.2		19.9	21.5		
UTGW62041S1	20	37.5		24.9	25.6		27.2
UTGW62255S1	22	40.7		26.5	30.4		
UTGW62461S1	24	43.9		26.2	31.7		33.5

For bulk packing (qty 100 pcs) add B at the end of cat. Nr. eg. UTGW61419S1B



New

Wall mounting receptacle for pin contacts (UTGW0- - -P1)

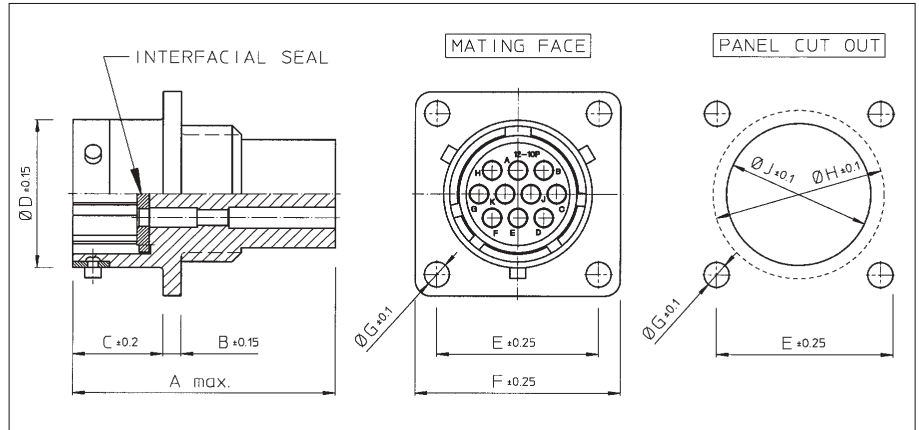

Part number	Shell size	A Max.	B ± 0.15	C ± 0.2	Ø D ± 0.15	E ± 0.25	F ± 0.25	Ø G ± 0.1	Ø J ± 0.1
UTGW0106P1	10	31.7	2.3	11.3	15.0	18.3	23.8	3.2	15.1
UTGW01210P1	12				19.0	20.6	26.2		18.2
UTGW01419P1	14				22.2	23.0	28.6		21.4
UTGW01626P1	16				25.3	24.6	31.0		24.6
UTGW02041P1	20	33.3	3.5	14.5	31.7	29.4	36.5	3.9	30.9
UTGW02255P1	22				34.9	31.8	39.7		34.1
UTGW02461P1	24				38.0	34.9	42.9		37.3

For bulk packing (qty 100 pcs) add B at the end of cat. Nr. eg. UTGW01419P1B

Wall mounting receptacle for socket contacts (UTGW0- - -S1)

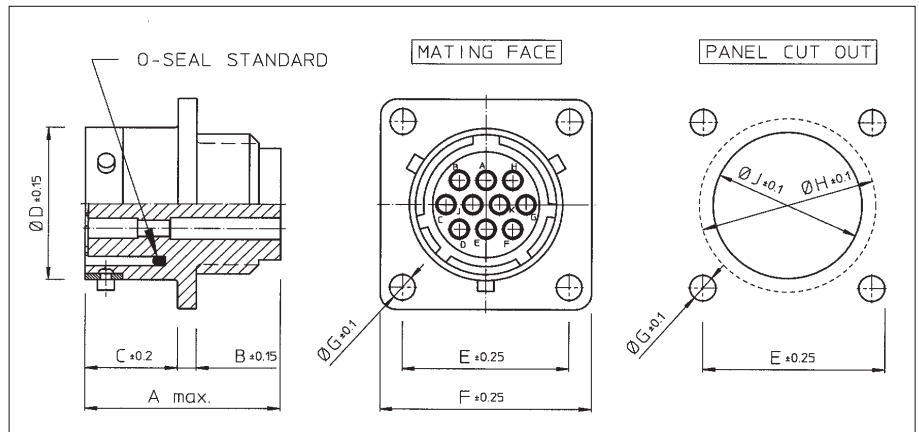

Part number	Shell size	A Max.	B ± 0.15	C ± 0.2	Ø D ± 0.15	E ± 0.25	F ± 0.25	Ø G ± 0.1	Ø J ± 0.1
UTGW0106S1	10	24.3	2.3	11.3	15.0	18.3	23.8	3.2	15.1
UTGW01210S1	12				19.0	20.6	26.2		18.2
UTGW01419S1	14				22.2	23.0	28.6		21.4
UTGW01626S1	16				25.3	24.6	31.0		24.6
UTGW02041S1	20	27.0	3.5	14.5	31.7	29.4	36.5	3.9	30.9
UTGW02255S1	22	28.0			34.9	31.8	39.7		34.1
UTGW02461S1	24	30.4			38.0	34.9	42.9		37.3

For bulk packing (qty 100 pcs) add B at the end of cat. Nr. eg. UTGW01419S1B



New

Free hanging receptacle for pin contacts (UTGW1- - -P1)

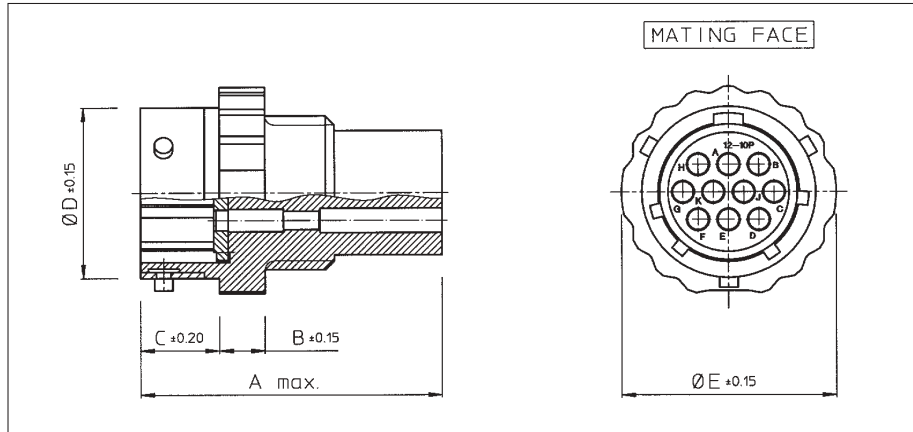

Part number	Shell size	A Max.	B ± 0.15	C ± 0.2	Ø D ± 0.15	Ø E ± 0.15
UTGW1106P1	10	31.7	5.0	8.65	15.0	19.5
UTGW11210P1	12				19.0	23.5
UTGW11419P1	14				22.2	27.0
UTGW11626P1	16				25.3	30.0
UTGW12041P1	20	33.3		12.05	31.7	36.5
UTGW12255P1	22			34.9	39.5	
UTGW12461P1	24			13.85	38.0	42.5

For bulk packing (qty 100 pcs) add B at the end of cat. Nr. eg. UTGW11419P1B

Free hanging receptacle for socket contacts (UTGW1- - -S1)

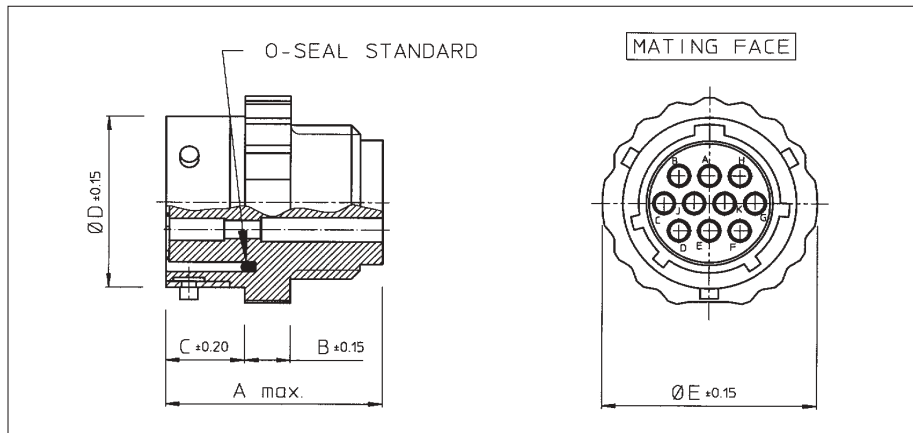

Part number	Shell size	A Max.	B ± 0.15	C ± 0.2	Ø D ± 0.15	Ø E ± 0.15
UTGW1106S1	10	24.3	5.0	8.65	15.0	19.5
UTGW11210S1	12				19.0	23.5
UTGW11419S1	14				22.2	27.0
UTGW11626S1	16				25.3	30.0
UTGW12041S1	20	25.9		12.05	31.7	36.5
UTGW12255S1	22			34.9	39.5	
UTGW12461S1	24			13.85	38.0	42.5

For bulk packing (qty 100 pcs) add B at the end of cat. Nr. eg. UTGW11419S1B



New

Intermateable cross reference list SEALOK versus MIL-C-26482 series 1

Sealok P/N	Description	Crimp 26482 S1	Solder 26482 S1
UTGW6106P1	Cable plug for pin contacts	MS3126*106P	MS3116*610P
UTGW61210P1		MS3126*1210P	MS3116*1210P
UTGW61419P1		MS3126*1419P	MS3116*1419P
UTGW61626P1		MS3126*1626P	MS3116*1626P
UTGW62041P1		MS3126*2041P	MS3116*2041P
UTGW62255P1		MS3126*2255P	MS3116*2255P
UTGW62461P1		MS3126*2461P	MS3116*2461P
UTGW6106S1	Cable plug for socket contacts	MS3126*106S	MS3116*610S
UTGW61210S1		MS3126*1210S	MS3116*1210S
UTGW61419S1		MS3126*1419S	MS3116*1419S
UTGW61626S1		MS3126*1626S	MS3116*1626S
UTGW62041S1		MS3126*2041S	MS3116*2041S
UTGW62255S1		MS3126*2255S	MS3116*2255S
UTGW62461S1		MS3126*2461S	MS3116*2461S
UTGW0106P1	Wall mounting receptacle for pin contacts	MS3120*106P	MS3110*610P
UTGW01210P1		MS3120*1210P	MS3110*1210P
UTGW01419P1		MS3120*1419P	MS3110*1419P
UTGW01626P1		MS3120*1626P	MS3110*1626P
UTGW02041P1		MS3120*2041P	MS3110*2041P
UTGW02255P1		MS3120*2255P	MS3110*2255P
UTGW02461P1		MS3120*2461P	MS3110*2461P
UTGW0106S1	Wall mounting receptacle for socket contacts	MS3120*106S	MS3110*610S
UTGW01210S1		MS3120*1210S	MS3110*1210S
UTGW01419S1		MS3120*1419S	MS3110*1419S
UTGW01626S1		MS3120*1626S	MS3110*1626S
UTGW02041S1		MS3120*2041S	MS3110*2041S
UTGW02255S1		MS3120*2255S	MS3110*2255S
UTGW02461S1		MS3120*2461S	MS3110*2461S

*Adaptable to standard 26482 termination





Plastic cable clamp with strain relief (UTG - - AC)

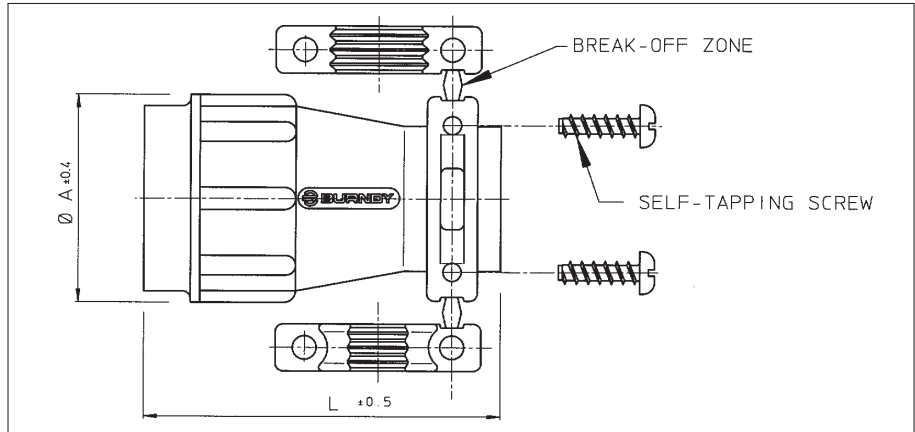

Part number	Shell size	Cable range \varnothing	$\varnothing A \pm 0.4$	$L \pm 0.5$
UTG10AC	10	3.0 - 8.7	21.0	40.0
UTG12AC	12	3.0 - 12.8	24.0	40.0
UTG14AC	14	4.0 - 13.8	27.0	46.0
UTG16AC	16	5.0 - 17.0	30.2	46.0
UTG18AC	18	5.0 - 19.0	33.3	50.0
UTG20AC	20	5.0 - 21.0	36.5	55.0
UTG22AC	22	5.0 - 23.0	39.7	60.0
UTG24AC	24	8.0 - 27.0	42.9	65.0

Plastic cable clamp with strain relief nut for waterprotected (IP65) applications (UTG - - PG)

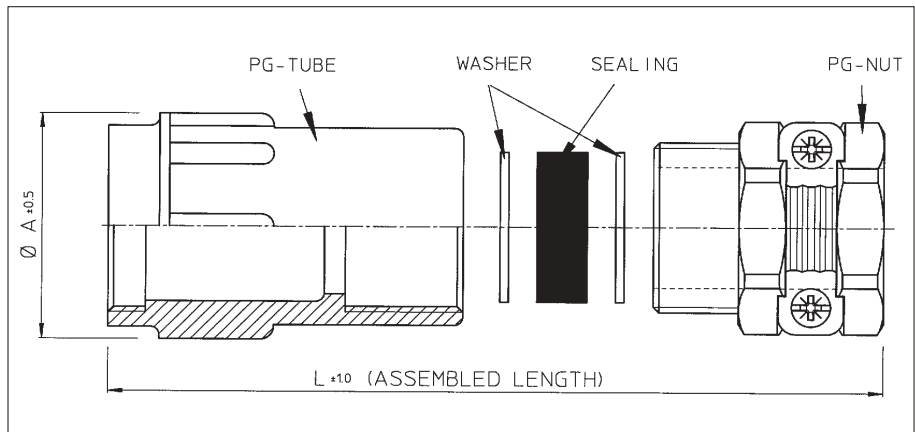

Part number	Shell size	Sealing* outer dia x inner dia's	$L \pm 1$	$A \pm 0.5$
UTG10PG	10	13.5 x 5 x 8	54	21.0
UTG12PG	12	16 x 7 x 10.5 x 13	57	24.0
UTG14PG	14	18.5 x 7 x 10.5 x 13 x 16	62	27.0
UTG16PG	16	20.5 x 8 x 10.5 x 13 x 16	68	30.2
UTG18PG	18	20.5 x 8 x 10.5 x 13 x 16	71	33.3
UTG20PG	20	26 x 11 x 15 x 18 x 22	82	36.5
UTG22PG	22	26 x 11 x 15 x 18 x 22	88	39.7
UTG24PG	24	35 x 19 x 23 x 27 x 31	103	42.9

*In order to accommodate different cable dia's, the sealing exists of different layers which can be pulled out easily.



New

Plastic cable clamp with strain relief nut for waterprotected (IP65) applications (UTG--ST)

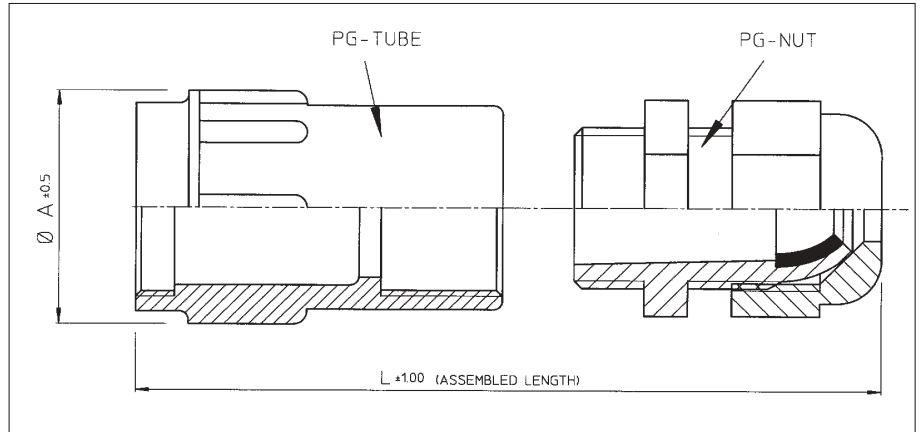

Part number	Shell size	Cable range	Dia. A ± 0.5	L ± 1
UTG10ST	10	2 - 6	21.0	64
UTG12ST	12	3 - 7	24.0	64
UTG14ST	14	6 - 9	27.0	69
UTG16ST	16	7 - 12	30.2	72
UTG18ST	18		33.3	76
UTG20ST	20	9 - 16	36.5	80
UTG22ST	22		39.7	86
UTG24ST	24	13 - 20	42.9	91



New

Right angle wall mounting adaptor for receptacle connectors (UT0--RA--)

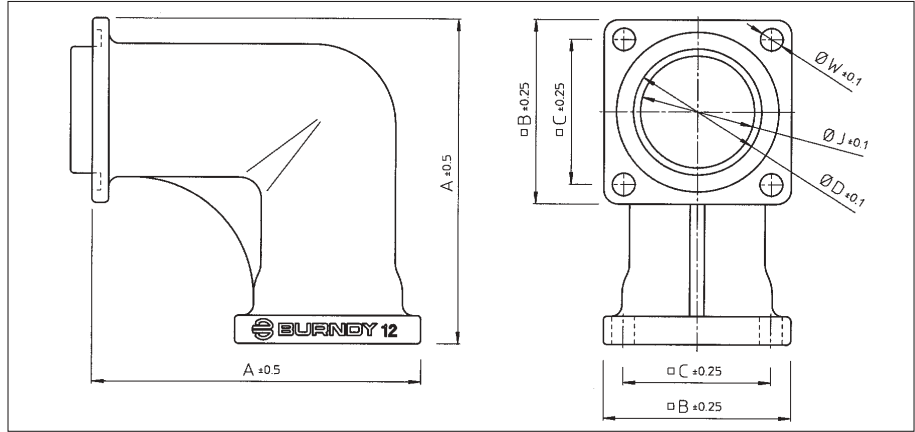

Part number	Shell size	A ± 0.5	$\varnothing B \pm 0.25$	$\varnothing C \pm 0.25$	$\varnothing D \pm 0.1$	$\varnothing W \pm 0.1$	$\varnothing J \pm 0.1$
UT010RAT	10	43.8	23.8	18.2	14.8	3.2	14.9
UT012RAT	12	46.2	26.2	20.5	17.9		18.0
UT014RAT	14	48.6	28.6	22.9	21.1		21.2
UT016RAT	16	51.0	31.0	24.5	24.3		24.4
UT018RAT	18	53.3	33.3	26.9	27.5		27.6
UT020RAT	20	56.5	36.5	29.2	30.6		30.7
UT022RAT	22	59.7	39.7	31.6	33.8		33.9
UT024RAT	24	62.9	42.9	34.8	37.0	3.9	37.1

Standard plating is tin. For black anodised plating replace "T" by "AB" e.g. UT012RAAB
 For waterprotected version with O-seals add "H" e.g. UT012HRAT or UT012HRAAB

Metal shrink boot adaptor (UTG--AD)

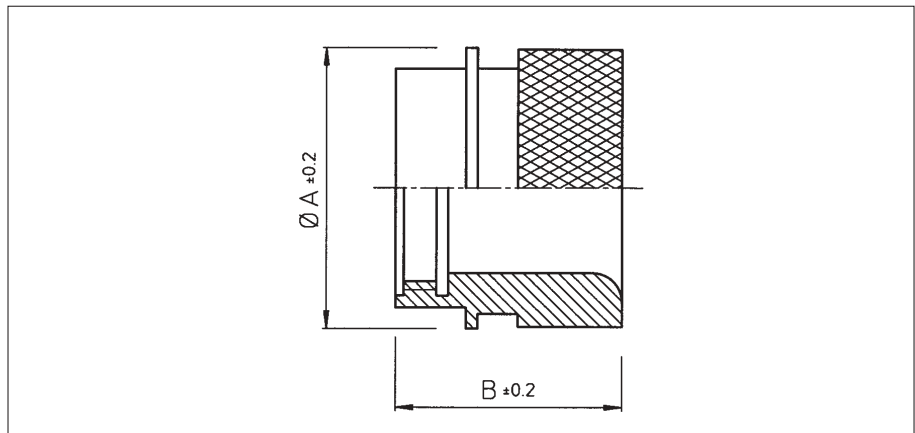

Part number	Shell size	$\varnothing A \pm 0.2$	B
UTG10AD	10	21.0	19.2
UTG12AD	12	24.0	
UTG14AD	14	27.0	
UTG16AD	16	30.0	21.5
UTG18AD	18	33.3	22.8
UTG20AD	20	36.5	
UTG22AD	22	39.7	
UTG24AD	24	42.9	21.9

Standard plating is anodised black. For tin plating add "T" at the end of the part number e.g. UTG12ADT



Metal cable clamp with strain relief (U--ACT)

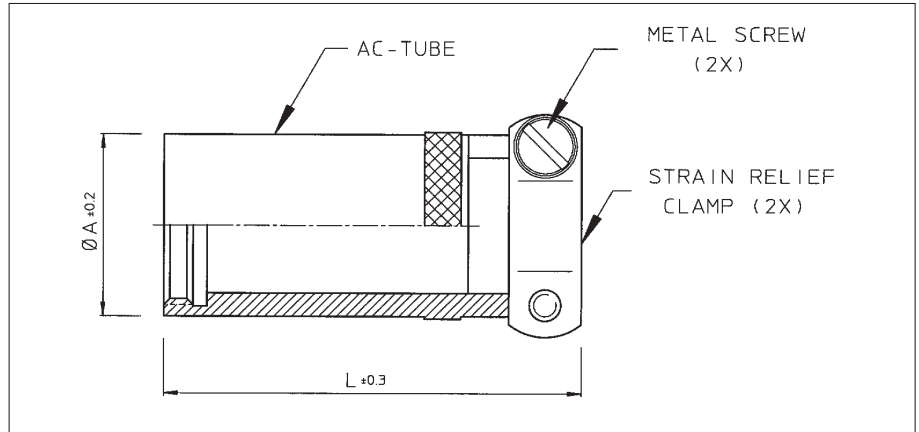

Part number	Shell size	A ^{±0.2}	L ^{±0.3}
U10ACT	10	16.7	41.2
U12ACT	12	20.2	41.0
U14ACT	14	23.1	46.0
U16ACT	16	26.2	49.3
U18ACT	18	29.7	53.5
U20ACT	20	32.6	56.6
U22ACT	22	35.8	58.6
U24ACT	24	39.2	62.6

Metal cable clamp with strain relief nut for waterprotected applications (UT0--PGT)

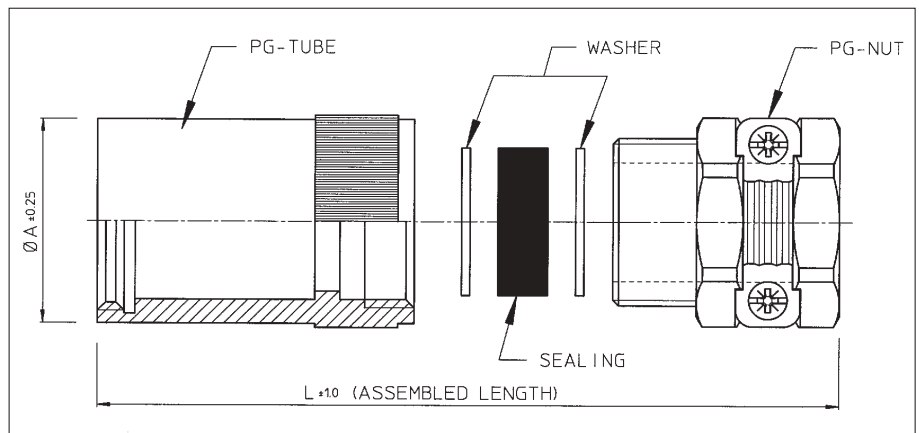

Part number	Shell size	Sealing* outer dia x inner dia's	L ^{±1}	A ^{±0.25}
UT010PGT	10	13.5 x 5 x 8	53	16.7
UT012PGT	12	16 x 7 x 10.5 x 13	57	20.1
UT014PGT	14	18.5 x 7 x 10.5 x 13 x 16	62	23.0
UT016PGT	16	20.5 x 8 x 10.5 x 13 x 16	68	26.2
UT018PGT	18	20.5 x 8 x 10.5 x 13 x 16	71	29.6
UT020PGT	20	26 x 11 x 15 x 18 x 22	82	32.5
UT022PGT	22	26 x 11 x 15 x 18 x 22	88	35.7
UT024PGT	24	35 x 19 x 23 x 27 x 31	103	39.2

*In order to accommodate different cable dia's, the sealing exists of different layers which can be pulled out easily.



New

Shielded cable clamp only suitable for UTGS connectors (UTGS----PGN)

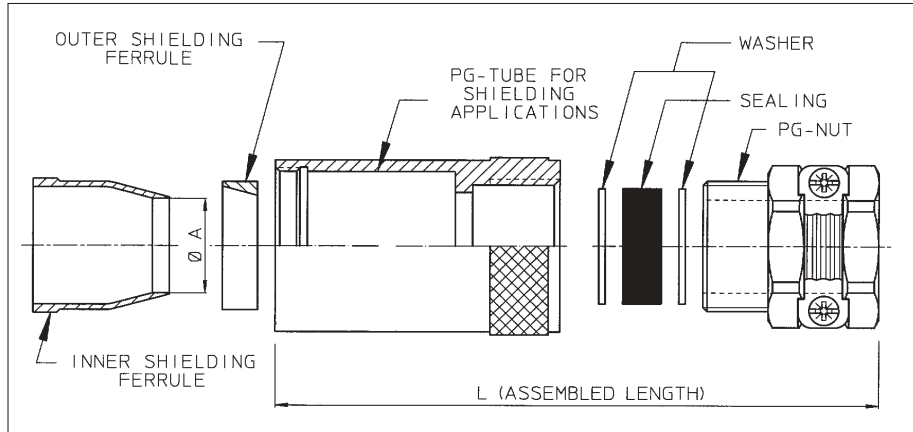

Part number		Shell size	Ø A	L	Sealing* outer dia x inner dia's
For pin contacts	For socket contacts				
	UTGS10PGN	10	8.8	54	13.5 x 5 x 8
	UTGS12PGN	12	12.0	57	16 x 7 x 10.5 x 13
	UTGS14PGN	14	14.4	62	18.5 x 7 x 10.5 x 13 x 16
	UTGS16PGN	16	16.4	68	20.5 x 8 x 10.5 x 13 x 16
	UTGS18PGN	18	16.8	71	20.5 x 8 x 10.5 x 13 x 16
UTGS20PGPN	UTGS20PGSN	20	22.3	82	26 x 11 x 15 x 18 x 22
UTGS22PGPN	UTGS22PGSN	22	22.3	88	26 x 11 x 15 x 18 x 22
UTGS24PGPN	UTGS24PGSN	24	30.0	103	35 x 19 x 23 x 27 x 31

*In order to accommodate different cable dia's, the sealing exists of different layers which can be pulled out easily.

New

Shielded cable clamp only suitable for UT0 connectors (UT0S----PG00T)

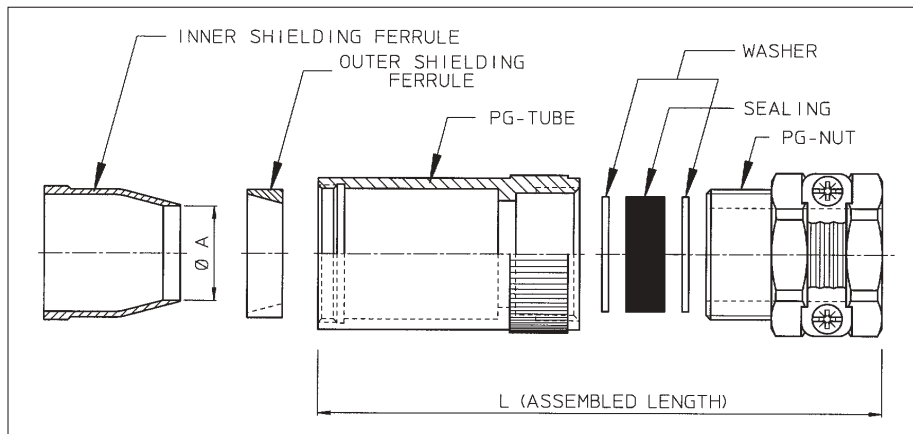

Part number		Shell size	Ø A	L	Sealing* outer dia x inner dia's
For pin contacts	For socket contacts				
	UT0S10PG00T	10	8.8	54	13.5 x 5 x 8
	UT0S12PG00T	12	12.0	57	16 x 7 x 10.5 x 13
	UT0S14PG00T	14	14.4	62	18.5 x 7 x 10.5 x 13 x 16
	UT0S16PG00T	16	16.4	68	20.5 x 8 x 10.5 x 13 x 16
	UT0S18PG00T	18	16.8	71	20.5 x 8 x 10.5 x 13 x 16
UT0S20PGP00T	UT0S20PGS00T	20	22.3	82	26 x 11 x 15 x 18 x 22
UT0S22PGP00T	UT0S22PGS00T	22	22.3	88	26 x 11 x 15 x 18 x 22
UT0S24PGP00T	UT0S24PGS00T	24	30.0	103	35 x 19 x 23 x 27 x 31

*In order to accommodate different cable dia's, the sealing exists of different layers which can be pulled out easily.



Metal right angle cable clamp with strain relief (L--LE)

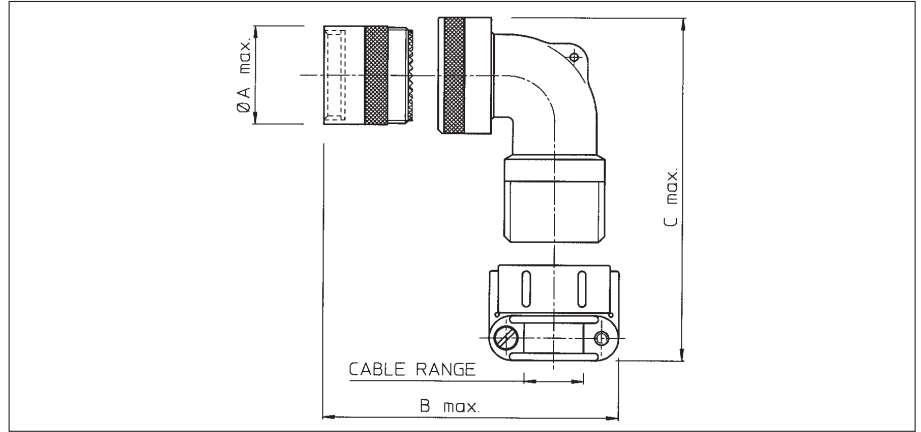

Part number	shell size	A max	B max	C max	Cable range
L10LE	10	18.3	61.4	64.0	7.2 - 11.1
L12LE	12	21.4	63.1	66.0	9.9 - 14.2
L14LE	14	24.7	66.6	75.8	13.0 - 15.8
L16LE	16	27.7	76.2	79.2	14.6 - 19.0
L18LE	18	31.0	81.6	96.3	17.8 - 23.8
L20LE	20	34.1	83.1	97.9	17.8 - 23.8
L22LE	22	37.4	87.4	106.6	19.0 - 31.7
L24LE	24	40.4	87.4	108.2	19.0 - 31.7



Environmental dustcap for plugs (UTG6--DCG)

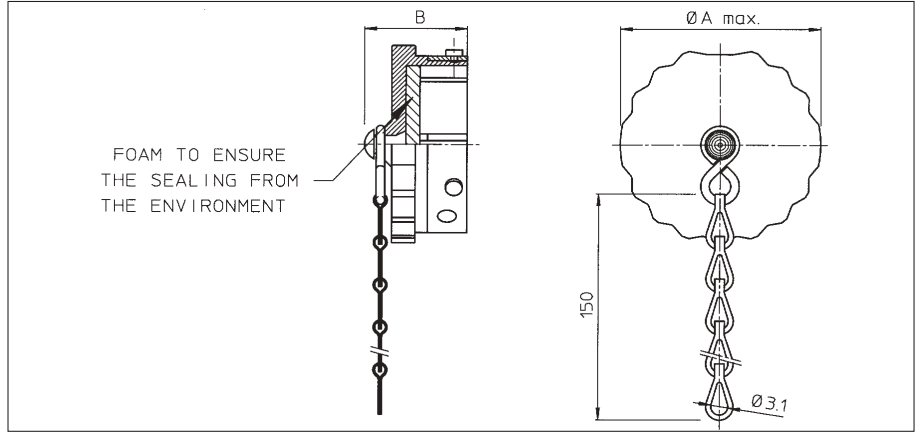

Part number	Shell size	A max.	B
UTG610DCG	10	20.0	20.8
UTG612DCG	12	24.0	
UTG614DCG	14	27.5	
UTG616DCG	16	30.5	
UTG618DCG	18	33.5	
UTG620DCG	20	36.5	22.5
UTG622DCG	22	40.0	
UTG624DCG	24	43.0	

For dustcap without chain skip "G" e.g. UTG612DC

Metal environmental dustcap for receptacles (UTG--DCG)

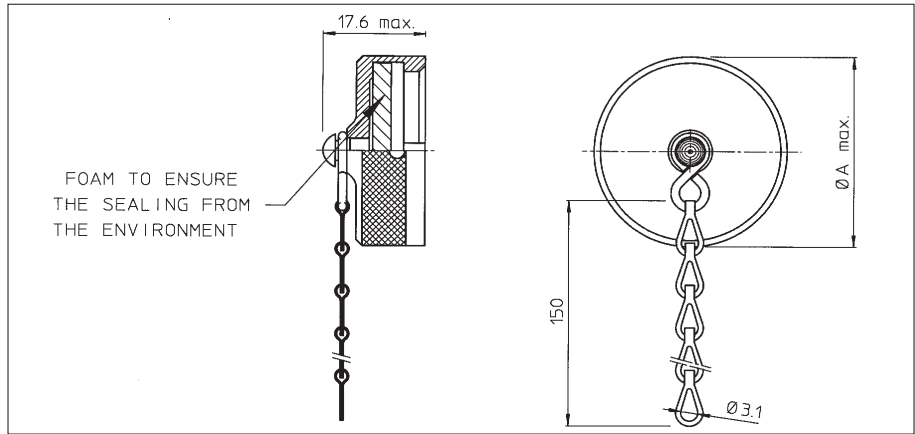

Part number	Shell size	A max.
UTG10DCG	10	20.8
UTG12DCG	12	24.9
UTG14DCG	14	28.1
UTG16DCG	16	31.3
UTG18DCG	18	34.4
UTG20DCG	20	37.6
UTG22DCG	22	40.8
UTG24DCG	24	43.9

For dustcap without chain skip "G" e.g. UTG12DC



New

Plastic environmental dustcap for receptacles (UTP--DCG)

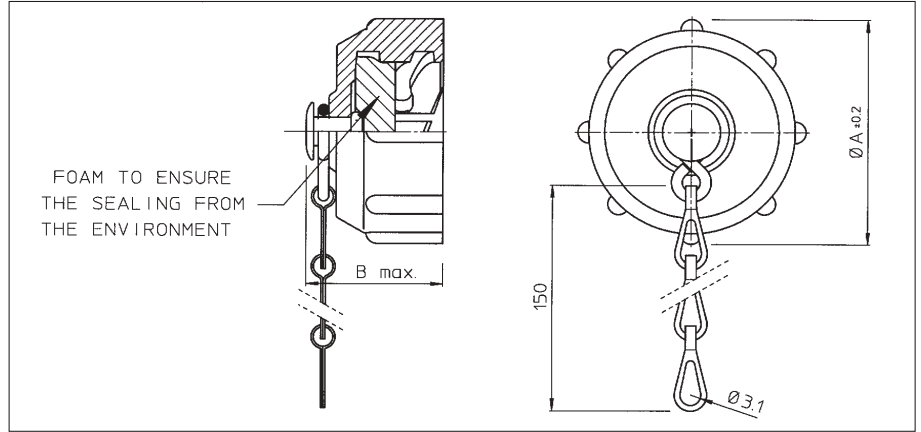

Part number	Shell size	Ø A ±0.2	B max.
UTP10DCG	10	26.7	19.3
UTP12DCG	12	31.4	20.0
UTP14DCG	14	34.5	
UTP16DCG	16	37.8	
UTP18DCG	18	40.8	20.2
UTP20DCG	20	43.9	
UTP22DCG	22	47.0	
UTP24DCG	24	50.1	21.8

For dustcap without chain skip "G" e.g. UTP12DC

Sealing for square flange receptacle (UTFD1-B)

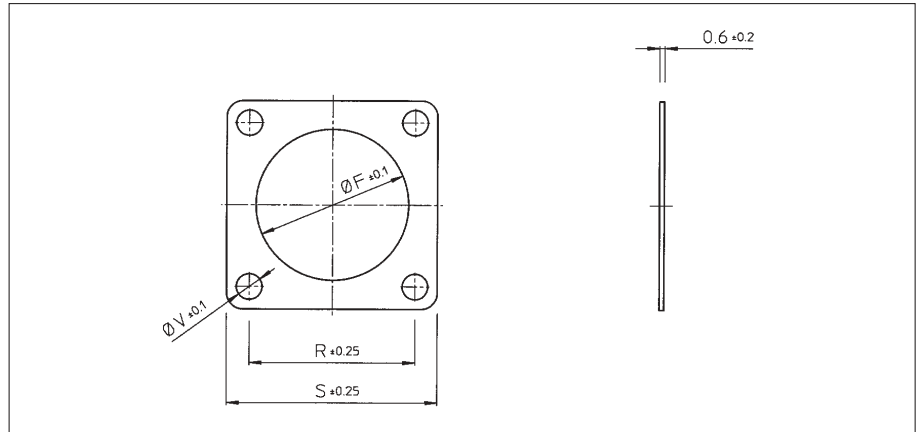

Part number	shell size	Ø F ±0.1	R ±0.25	S ±0.25	Ø V
UTFD12B	10	15.9	18.3	23.8	3.3
UTFD13B	12	19.0	20.6	26.2	
UTFD14B	14	22.2	23.0	28.6	
UTFD15B	16	25.4	24.6	31.0	
UTFD16B	18	28.6	27.0	33.3	
UTFD17B	20	31.8	29.4	36.5	
UTFD18B	22	34.9	31.8	39.7	
UTFD19B	24	38.1	34.9	42.9	4.0



Plastic connector with quick mating feature

Description

The BANTAMATE II cylindrical plastic connector has been designed for use in applications requiring a high number of mating cycles and rapid connections and disconnections.

Bantamate II meets minimum durability requirements of 5000 mating/unmating cycles by using a unique contact wiping system consisting of a lubricant saturated foam pad bonded to a spring loaded stripper plate within the receptacle or plug. On mating, the stripper plate is pushed deep into the connector wiping a thin film of lubricant onto the male contacts. A distinctive shape provides mating ease in blind or difficult to reach applications. Some typical applications would include test equipment, medical diagnostic equipment, or any of the hardware interconnections found in the modern electronic office.

Features and benefits

- 5000 mating / unmating cycles
- Lubricated male contacts with spring actuated foam plate
- Quick and easy installation with latching mechanism
- Easy mating due to the positive polarisation, even in blind spots
- Unmated male contacts are protected by the spring actuated plate
- Available with 4, 12, 19, 30, and 46 contact positions.
- Applicable for front or rear panel mounting as well as free hanging applications
- UL recognised File number E31151
- CSA certified LR54977



Performance characteristics

Operating temperature:	-55°C to +125°C
Insulation resistance:	5000 MΩ min.
Test potential:	2000 VAC
Durability:	Min. 5000 matings cycles
Vibration resistance:	5-50Hz, 0,5 dA; 8 hours axis
Thermal shock:	5 cycles -55°C to +105°C
Humidity:	10 days at 85% RH, +85°C

Construction

Connector body and strain relief:	Glass filled thermoplast UL94-V0
Colour:	black
Locking latch and hook:	Stainless steel, passivated
Compression Spring:	Music wire, Nickel plated
Lubricating pad:	Polyurethane foam
Rivet:	Brass, Tin plated
Strain relief screws:	Steel, Cadmium plated

Contact accommodation

- "MBG" connectors accept Trim-Trio crimp-type removable snap-lock contacts (see contact section)
- Contacts to be ordered separately.

How to order

Connector family	MBG	12	P	1
Insert arrangement:	4, 12, 19, 30, 46 positions			
Body variation:	P: Plug body R: Receptacle body S: Strain relief			
Design variation:	1: Standard version with male contacts in receptacle 11: Reversed version with male contacts in plug			



Female plug connector for socket contacts (MBG--P1) - Standard version
Male plug connector for pin contacts (MBG--P11) - Reversed version

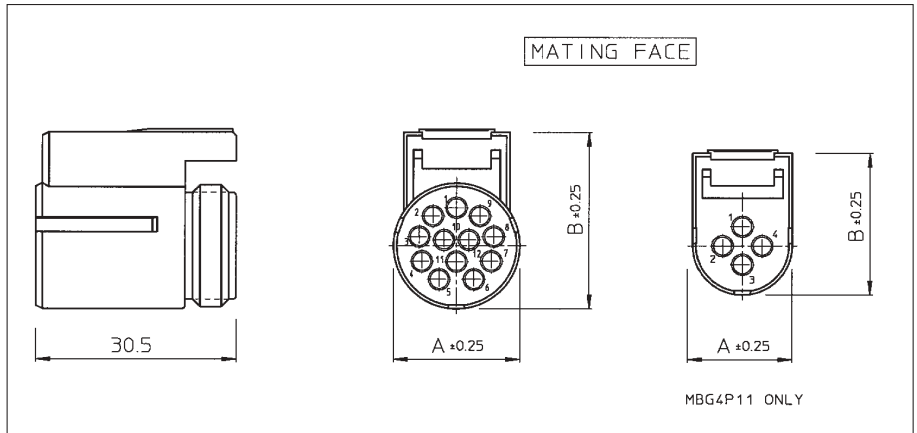

Female plug	Part number	Male plug	$\varnothing A \pm 0.25$	$B \pm 0.25$
MBG4P1		MBG4P11	15.08	21.90
MBG12P1		MBG12P11	19.43	27.25
MBG19P1		MBG19P11	22.83	30.53
MBG30P1		MBG30P11	27.94	35.51
MBG46P1		MBG46P11	34.42	41.91

Panel mounting male receptacle connector for pin contacts (MBG--R1) - Standard version
Panel mounting female receptacle connector for socket contacts (MBG--R11) - Reversed version

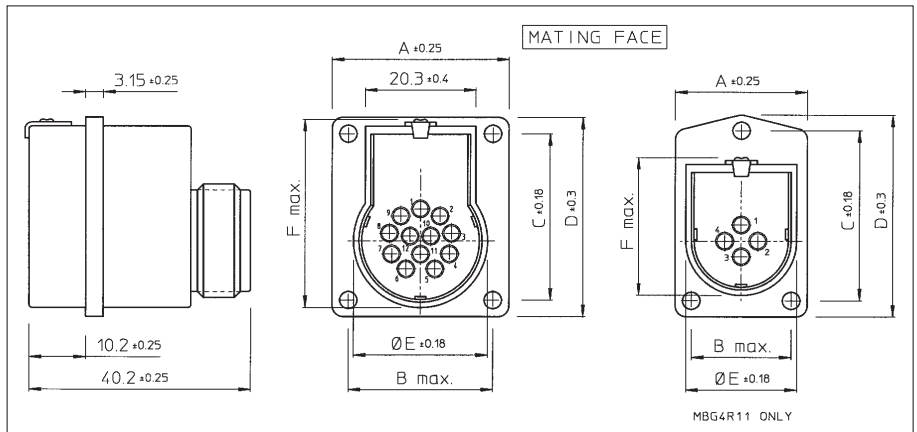

Part number	Male Receptacle	Female Receptacle	$\varnothing A \pm 0.25$	B max.	$C \pm 0.18$	$D \pm 0.30$	$\varnothing E \pm 0.18$	F max.
MBG4R1		MBG4R11	23.90	18.08	31.45	37.36	20.07	29.46
MBG12R1		MBG12R11	32.49	26.54	30.76	36.86	24.64	34.93
MBG19R1		MBG19R11	32.44	26.54	34.04	40.13	27.86	38.10
MBG30R1		MBG30R11	35.61	28.65	38.00	44.91	38.10	43.31
MBG46R1		MBG46R11	42.24	35.13	46.94	54.05	39.70	49.61



Strain relief (MBG--S1)

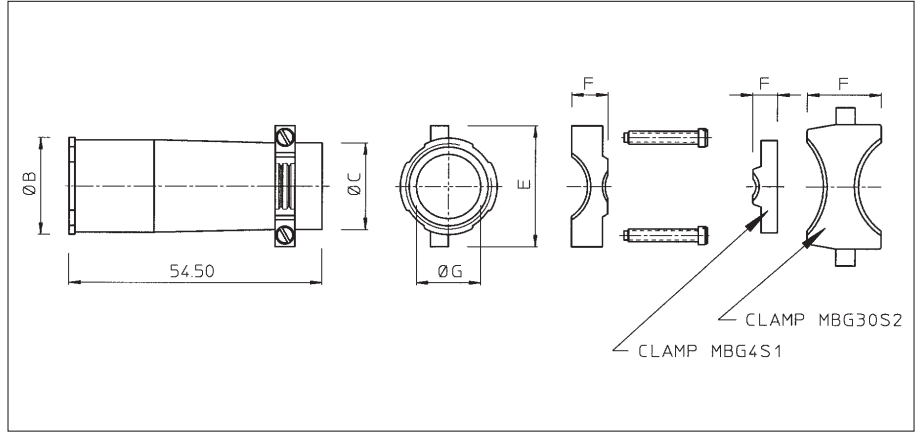

Part number	$\varnothing C$	$\varnothing D$	E	F	Cable range $\varnothing G$ side A	Cable range $\varnothing G$ side B
MBG4S1	12.2	15.0	20.1	5.3	8.51/6.35	-
MBG12S1	18.8	21.1	26.4	7.9	11.30/7.65	14.99/11.38
MBG19S1	21.3	24.4	29.0	9.4	13.08/8.66	17.53/13.12
MBG30S1	26.7	29.0	34.5	16.3	19.02/15.88	22.86/19.05
MBG30S2	26.7	29.0	34.5	15.9	12.67/10.01	15.85/12.70
MBG46S1	Not available					

Insert arrangements and moulded-in contact identification

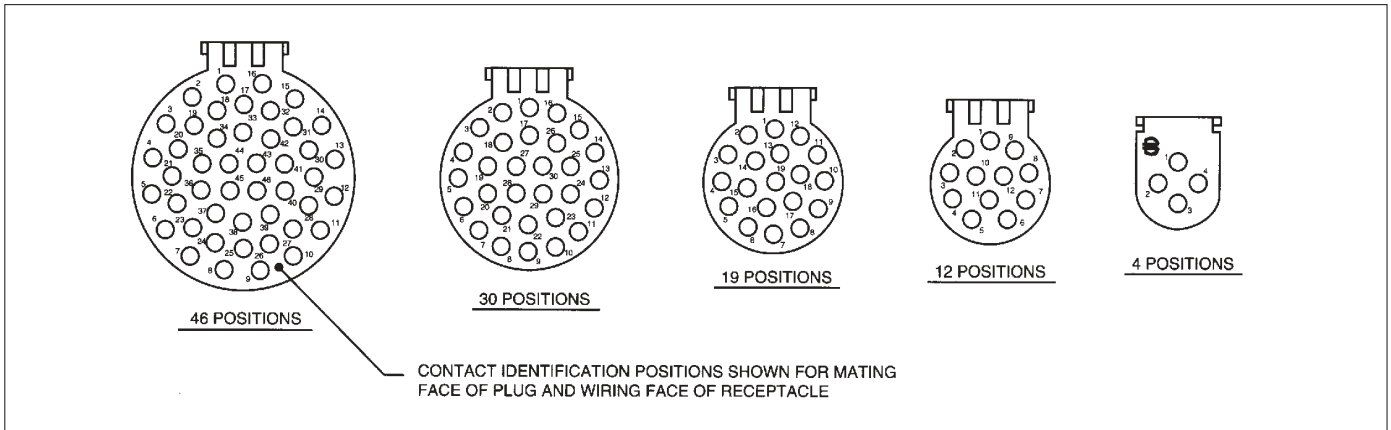

Contact identification positions shown are for mating face of plug and wiring face of receptacle.



Panel cut-out dimensions for receptacle - Standard version (MBG--R1)

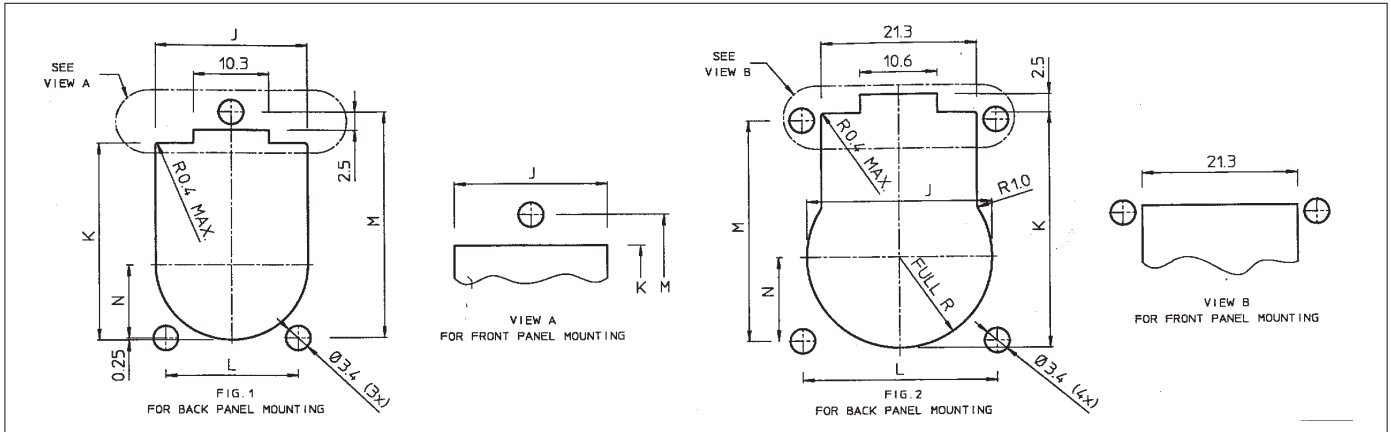

Part number	Fig.	J	K	L	M	N
MBG4R1	1	20.86	27.41	18.08	31.45	10.16
MBG12R1	2	25.30	32.74	26.54	30.76	11.65
MBG19R1	2	28.50	35.89		34.04	13.32
MBG30R1	2	33.73	40.97	28.65	38.00	15.49
MBG46R1	2	40.36	47.22	35.13	46.94	18.85

Panel cut-out dimensions for receptacle - Reversed version (MBG--R11)

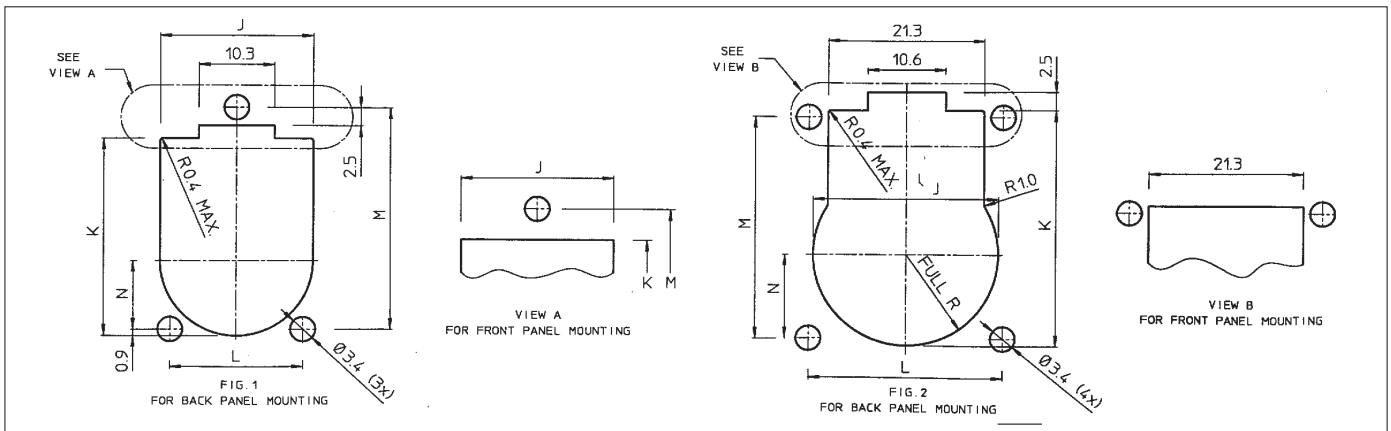

Part number	Fig.	J	K	L	M	N
MBG4R11	1	20.86	27.41	18.08	31.45	10.16
MBG12R11	2	25.30	32.74	26.54	30.76	11.65
MBG19R11	2	28.50	35.89		34.04	13.32
MBG30R11	2	33.73	40.97	28.65	38.00	15.49
MBG46R11	2	40.36	47.22	35.13	46.94	18.85



Overview rectangular TRIM TRIO connectors

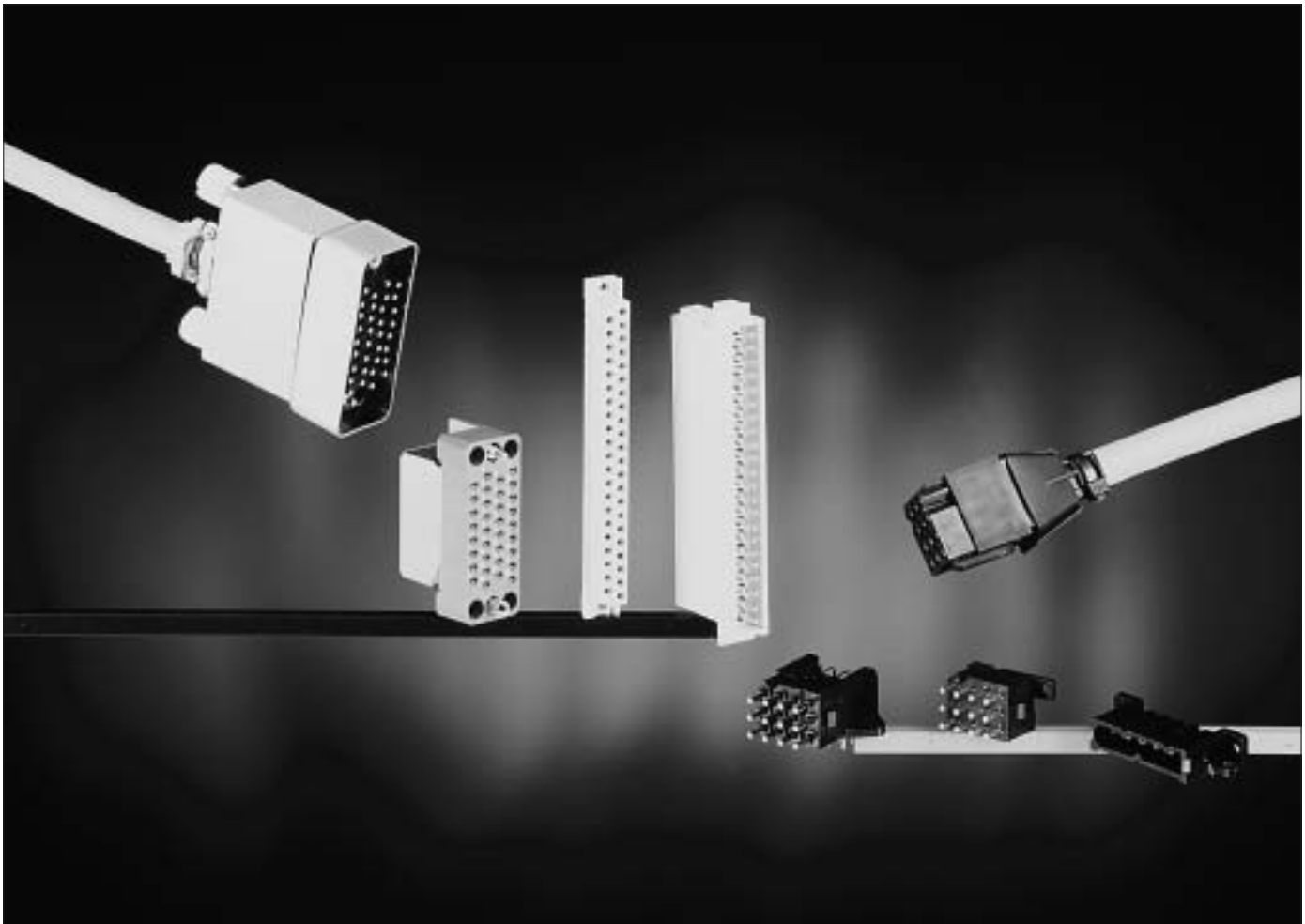

Selection matrix Rectangular connectors

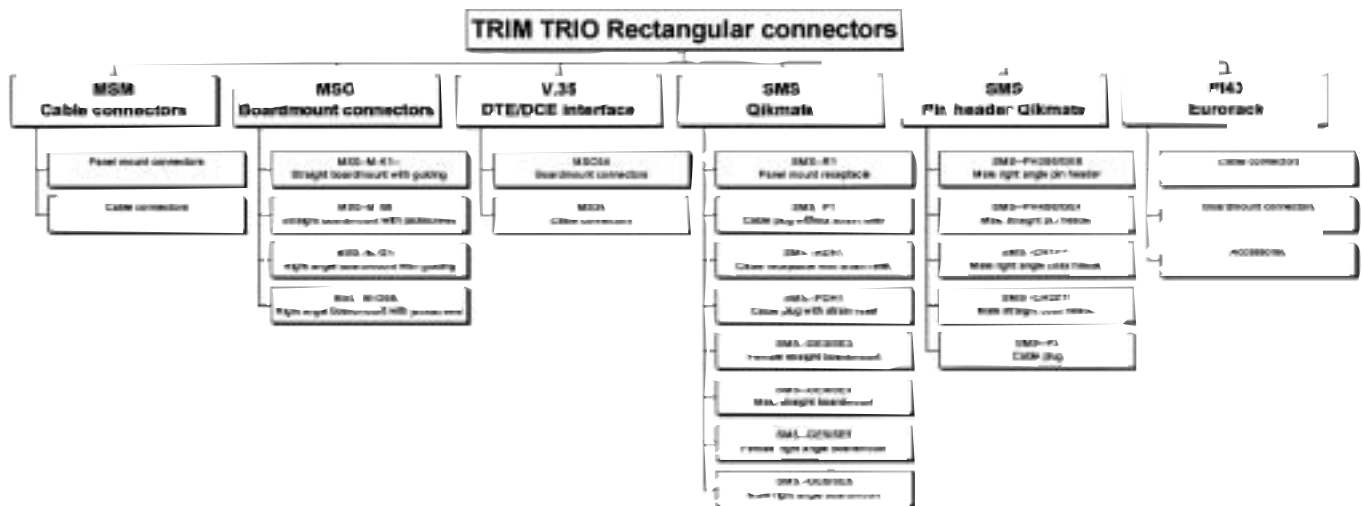



High performance hyfen rectangular cable connectors

Description

MSM rectangular connectors offers an extremely reliable, rugged, and versatile connection system .

They are a range of multiway connectors available in 8 sizes from 14 to 104 positions. MS-M cable connectors can be offered with a full range of hardware and accessories. Guiding pins and sockets, turnable jackscrews, a variety of cable hoods, pin protection shrouds and discrimination pins make this connector range a truly versatile system.



Features and benefits

- Connectors supplied pre-assembled except for panel mount versions.
- Available in 14-20-26-34-42-50-75 and 104 positions.
- 34 contact positions suitable for V.35 applications (see V.35 section)
- Full range of accessories available including hoods, strain relief clamps, guide pins, jackscrews and pin protection shrouds.
- MS-M hyfen complies with NFC 93426 - HE 621-622 and MIL-C-28748 specifications.

Performance characteristics

Operating temperature:	-55°C to +125°C
Insulation resistance:	5000 MΩ min.
Test potential:	2000 VAC
Durability:	500 matings and unmatings.
Vibration resistance	Per MIL-STD 202 method 204
Shock:	Per MIL-C-STD 202 method 207

Construction

Connector Material :	Glass filled Phenolic
Flammability rating :	UL94-V0
Hoods:	Aluminium alloy - anodized
Cable clamps:	Stainless steel
Polarizing hardware:	Brass nickel plated
Shrouds:	Aluminium alloy colour less anodized

Contact accommodation

- “MS-M” Hyfen connectors accept Trim-Trio crimp-type removable snap-lock contacts (see contact section)
- Contacts to be ordered separately.

How to order

Series	MS MSD	14	PM	1	S9
Connector Density:	14-20-26-34-42-50-75				
Plug/Receptacle:	PM-RM				
Variation Number:					
Accessories/Shroud:					



Contact arrangement

14 POS.

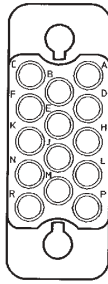

20 POS.

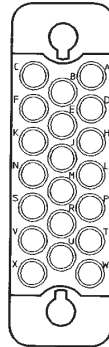

26 POS.

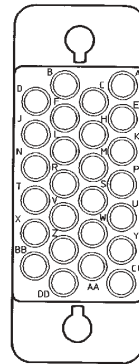

34 POS.

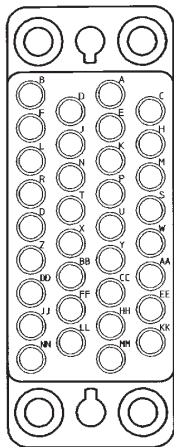

42 POS.

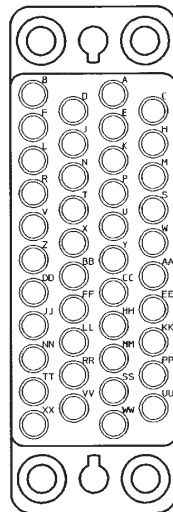

50 POS.

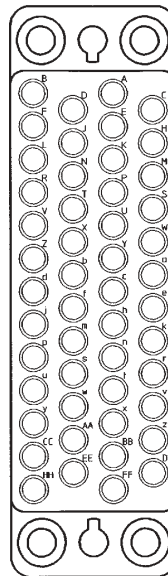

75 POS.

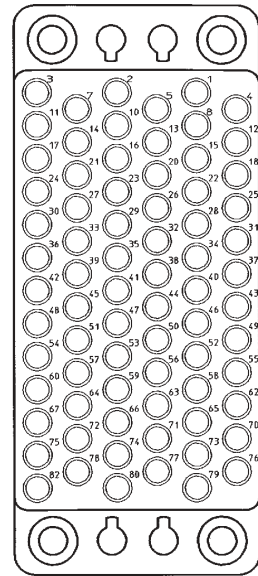

The contact position identification letters or numbers shown in the above diagrams apply to MS-M plug and receptacle connectors. Dimensionally, corresponding types of plug and receptacle mouldings are the same and differ only in that the contact position lettering/numbering of the plug (MS-PM) is a mirror image of that of the receptacle (MS-RM). Note that pins and/or sockets can be used in either the plug or receptacle moulding.

Note: Contact identification is shown for wiring face of the receptacle and mating face at plug connector.



Panel mount connectors with guiding hardware (MS--M1)

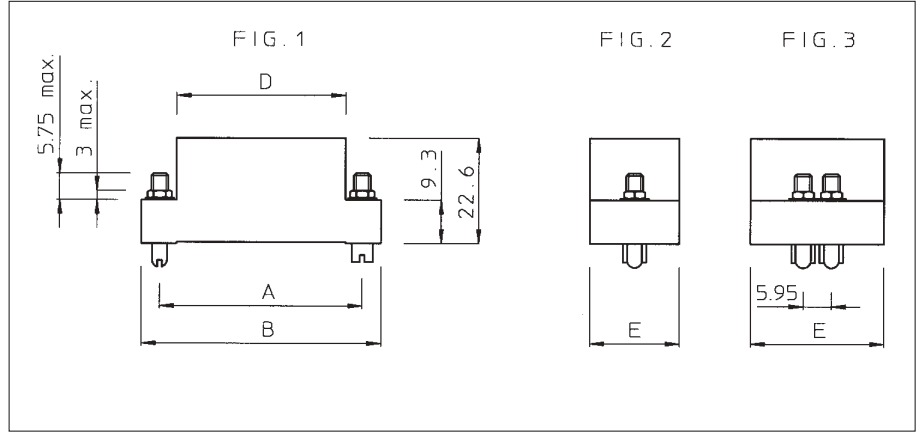

Connector size	Part number		A	B	D	E	Fig.
	Plug version for male contacts	Receptacle version for female contacts					
14	MS14PM1	MS14RM1	23.8	31.8	20.1	11.7	1-2
20	MS20PM1	MS20RM1	31.75	39.65	27.95	11.7	
26	MS26PM1	MS26RM1	33.3	41.3	27.2	15.0	
34	MS34PM1	MS34RM1	42.8	50.8	35.7	19.05	
42	MS42PM1	MS42RM1	50.55	58.65	42.95		
50	MS50PM1	MS50RM1	57.95	65.85	50.85	18.95	1-3
75	MS75PM1	MS75RM1				28.1	

(*) Complete part number with "S" for connector with protective shroud.

Panel mount connectors with fixed jackscrew hardware (MS--M58)

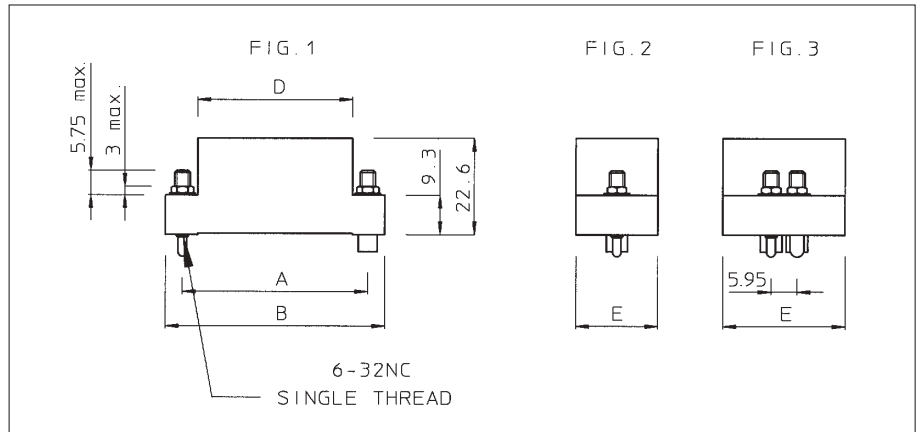

Connector size	Part number		A	B	D	E	Fig.
	Plug version for male contacts	Receptacle version for female contacts					
14	MS14PM58	MS14RM58	23.8	31.8	20.1	11.7	1-2
20	MS20PM58	MS20RM58	31.75	39.65	27.95	11.7	
26	MS26PM58	MS26RM58	33.3	41.3	27.2	15.0	
34	MS34PM58	MS34RM58	42.8	50.8	35.7	19.05	
42	MS42PM58	MS42RM58	50.55	58.65	42.95		
50	MS50PM58	MS50RM58	57.95	65.85	50.85	18.95	1-3
75	MS75PM58	MS75RM58				28.1	

(*) Complete part number with "S" for connector with protective shroud.



Cable connector with metal butterfly hood and guiding hardware (MS--M120)

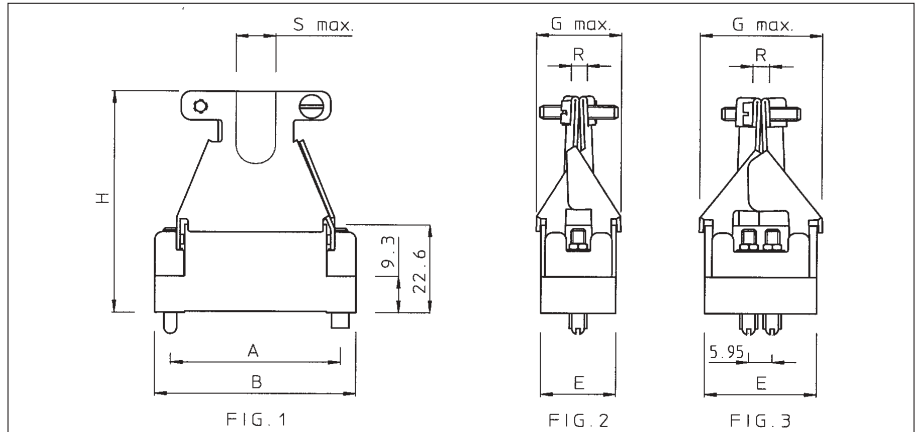

Connector size	Part number		A	B	E	G max.	H	S max.	R max.	Fig.
	Plug version for male contacts	Receptacle version for female contacts								
14	MS14PM120	MS14RM120	23.8	31.8	11.7	14.7	48.7	8.5	8	1-2
20	MS20PM120	MS20RM120	31.75	39.65	15.0	18		10	8.5	
26	MS26PM120	MS26RM120	33.3	41.3				9		
34	MS34PM120	MS34RM120	42.8	50.8			13			
42	MS42PM120	MS42RM120	50.55	58.65	19.05	22.2	56.7	16	11	
50	MS50PM120	MS50RM120	57.95	65.85	18.95	21		19.5		
75	MS75PM120	MS75RM120			28.1			31.8		21

(*) Complete part number with "S" for connector with protective shroud.

Cable connector with metal butterfly hood and fixed jackscrew hardware (MS--M140)

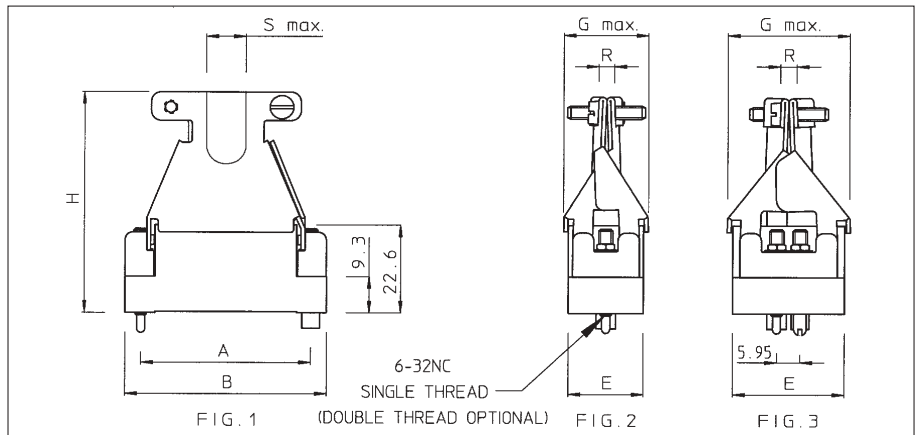

Connector size	Part number		A	B	E	G max.	H	S max.	R max.	Fig.
	Plug version for male contacts	Receptacle version for female contacts								
14	MS14PM140	MS14RM140	23.8	31.8	11.7	14.7	48.7	8.5	8	1-2
20	MS20PM140	MS20RM140	31.75	39.65	15.0	18		10	8.5	
26	MS26PM140	MS26RM140	33.3	41.3				9		
34	MS34PM140	MS34RM140	42.8	50.8			13			
42	MS42PM140	MS42RM140	50.55	58.65	19.05	22.2	56.7	16	11	
50	MS50PM140	MS50RM140	57.95	65.85	18.95	21		19.5		
75	MS75PM140	MS75RM140			28.1			31.8		21

(*) Complete part number with "S" for connector with protective shroud.



MSD104 receptacle cable connector with central jackscrew (MS104RM-)

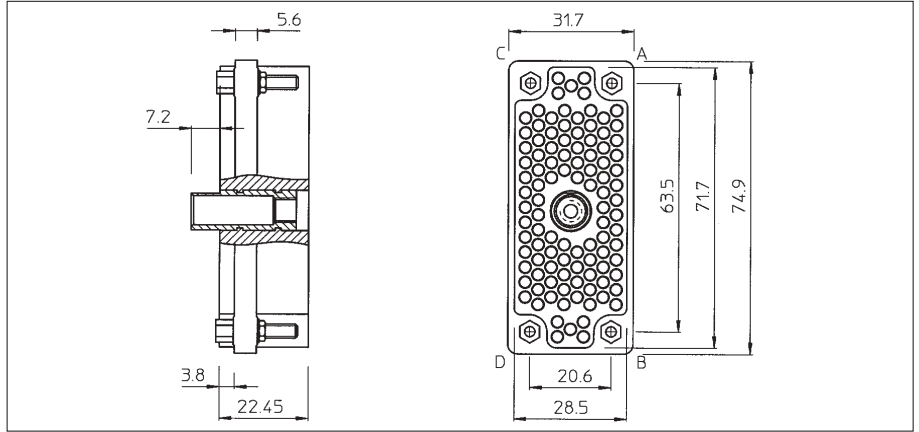

Connector size	Part number	Orientation of guide sockets
104	MSD104RM489	A, B, C, D

Other orientations of guide sockets on request

MSD104 plug cable connector without cable clamp (MS104PM-)

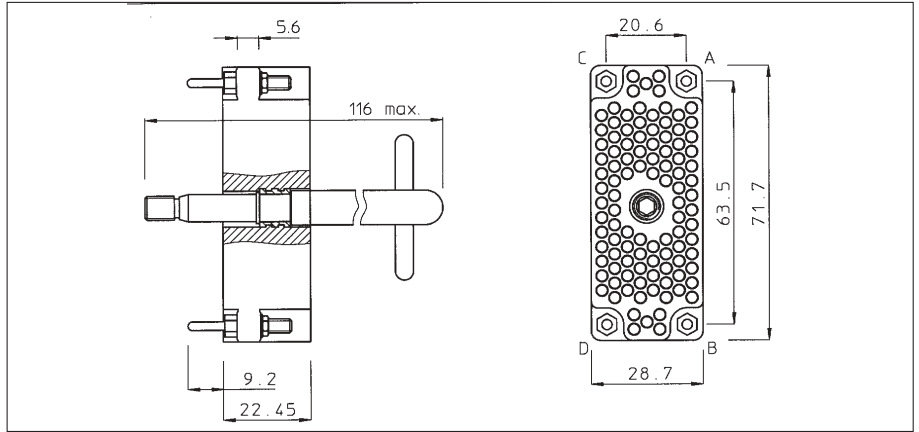

Connector size	Part number	Orientation of guide sockets
104	MSD104PM494	A, B, C, D

Other orientations of guide sockets on request



MS104 cable connector with cable clamp (MS104PM-)

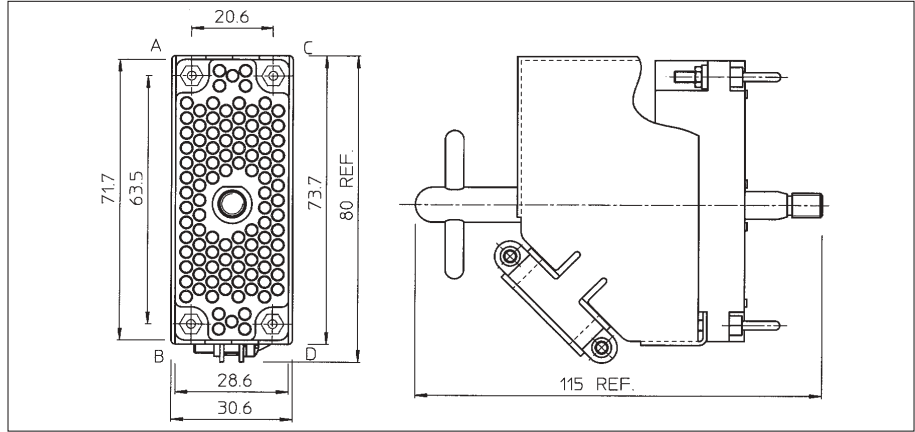

Connector size	Part number	Orientation of guide pins
104	MS104PM494(*)GE10	A, B, C, D

Other orientations of guide sockets on request

(*) Complete part number with "S" for connector with protective shroud.

MS-M panel cut-out dimensions

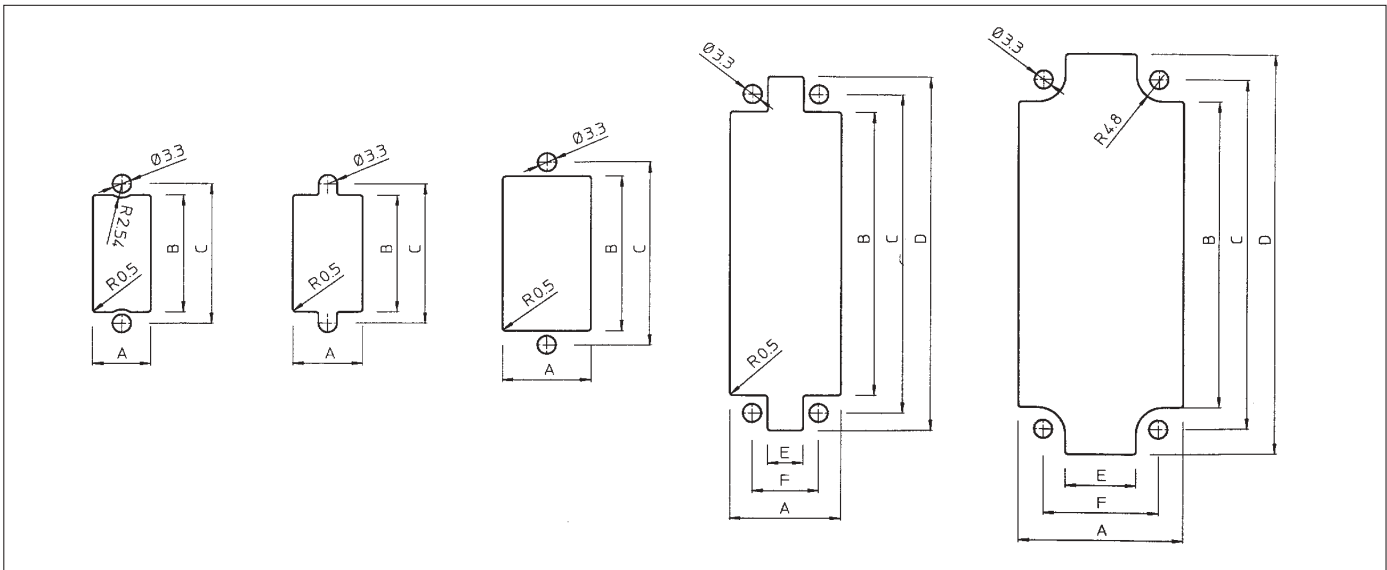

Connector size	Fig.	A	B	C	D	E	F
14	1 or 2	12.45	20.83	23.80			
20	1 or 2	12.45	28.70	31.75			
26	2 or 3	15.75	28.20	33.32			
34	4		36.60	42.82	49.30		
42	4	19.81	43.70	50.55	56.90	6.35	11.89
50	4		51.56	57.95	64.30		
75	4	29.08				14.22	19.40
104	5	29.46	55.63	63.50	72.64	12.70	20.62



Rectangular boardmount connectors to mate with MSM cable connectors

Description

The MSO series, derived from the MSM series, is for straight or right-angled application on a printed circuit board. Pre-assembled MSO connectors with pin or socket N(16 contacts are intermateable with the existing MSM rectangular cable connectors.

The N° 16 TRIM TRIO .0625" (1.6mm) diameter contacts are available in either solid machined or stamped and formed versions.

The polarizing hardware can be delivered in either guiding or jackscrew versions.

Features and benefits

- Connectors supplied pre-assembled with dip solder contacts.
- Contacts available in solid machined or stamped and formed version.
- Available in 9-18-34-50-75 positions.
- For right-angled versions, there is a choice of 9-18 and 34 contact positions.
- 34 contact positions suitable for V.35 applications (see section V.35)
- Polarising hardware prevent mismatching.
- UL94-V0 rated thermoplast.

Performance characteristics

Operating temperature:	-55°C to +125°C
Current rating:	7.5 Amp
Contact resistance:	≤ 3 mΩ
Insulation resistance:	5000 M min.
Test potential:	2000 VAC
Operating voltage:	750 V RMS
Durability:	500 matings and unmatings.

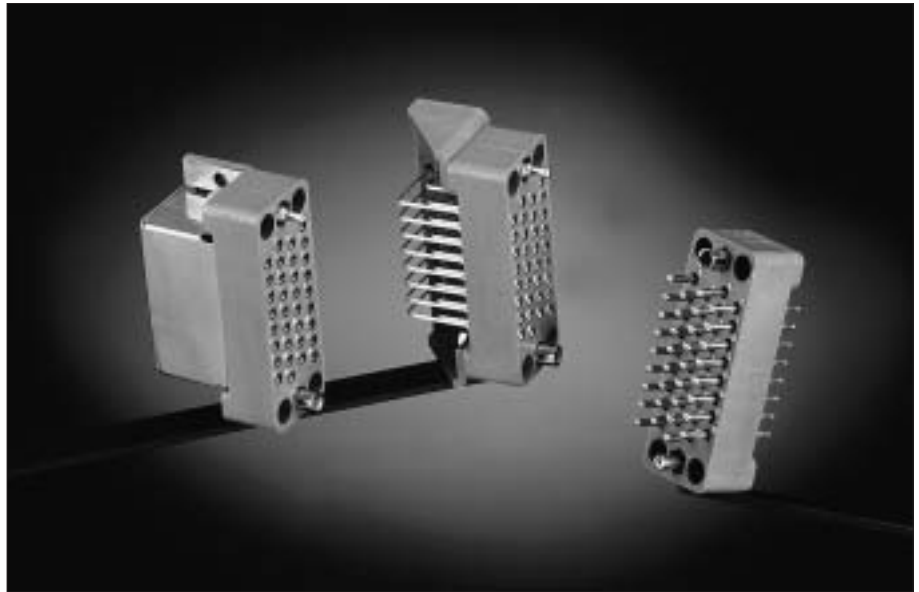

Construction

Connector Material : Glass filled polysulfone
 Flammability rating : UL94-V0

Polarizing hardware: Brass nickel plated

Contacts: High conductive copper alloy

Plating table

Plating for solid machined contacts:
 No digit (std) = Min. 0.4 μ Gold all over, over Nickel.

J = Gold flash all over, over Nickel.

T = 3 - 5μ Tin all over

Plating for Stamped and formed contacts :

K9 (std) = Min. 0.4μ Gold in contact area,
 3 - 5μ SnPb on solder tail.

T = 3 - 5μ Tin all over

Intermateability

- "MSO" with pre-assembled contacts are intermateable with the "MSM" rectangular cable connectors equipped with Trim-Trio crimp-type removable snap-lock contacts (see contact section)
- Contacts to be ordered separately.

How to order

Connector family	MSO	34	M	R	G	58	SE1	K9
Contact arrangement								
N° 16 contacts								
Type of housing	P: Plug body with male contacts R: Receptacle body with female contacts							
Contact termination	K: straight dipsolder G: Right angle dipsolder							
Type of hardware	1: Guide pin and socket 58: Threaded jackscrew pin and socket							
Design variation	E1: Solid machined contacts SE1: stamped and formed contacts							
Plating indication								



Straight boardmount with guiding hardware (MSO--M-K1--)

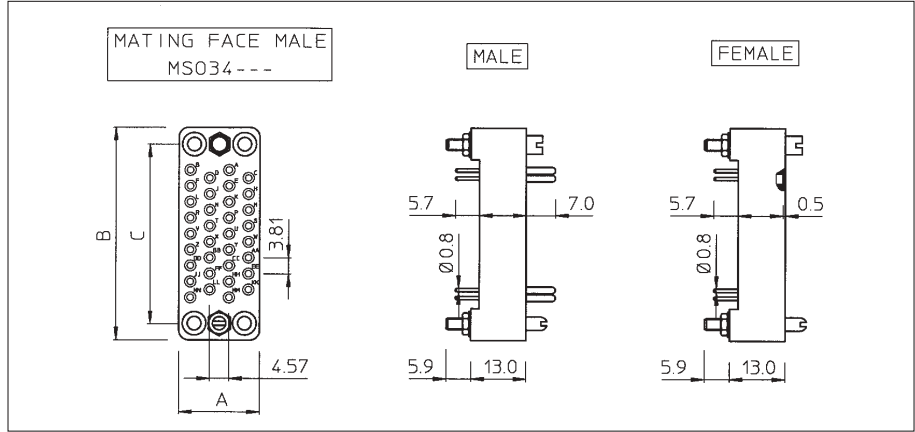

connector size	Part number				A	B	C
	Version with solid machined contacts		Version with stamped and formed contacts				
	male	female	male	female			
9	MSO9MPK1E1	MSO9MRK1E1	MSO9MPK1SE1K9	MSO9MRK1SE1K9	9.5	33.3	25.4
18	MSO18MPK1E1	MSO18MRK1E1	MSO18MPK1SE1K9	MSO18MRK1SE1K9	15.2	65.8	57.9
34	MSO34MPK1E1	MSO34MRK1E1	MSO34MPK1SE1K9	MSO34MRK1SE1K9	19.0		
50	MSO50MPK1E1	MSO50MRK1E1	MSO50MPK1SE1K9	MSO50MRK1SE1K9	18.9		
75	MSO75MPK1E1	MSO75MRK1E1	MSO75MPK1SE1K9	MSO75MRK1SE1K9	19.4		

For other platings: See plating table.

Other solder tail lengths on request

Selective loading on request

New

Straight boardmount with jackscrew hardware (MSO--M-K58--)

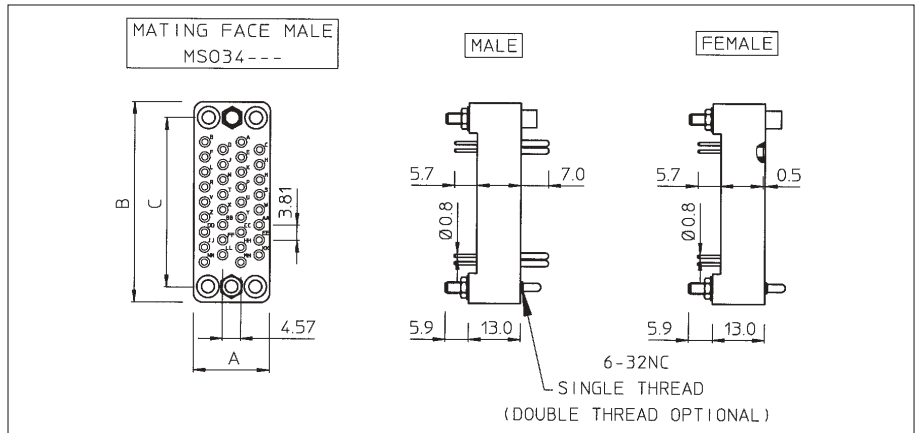

connector size	Part number				A	B	C
	Version with solid machined contacts		Version with stamped and formed contacts				
	male	female	male	female			
9	MSO9MPK58E1	MSO9MRK58E1	MSO9MPK58SE1K9	MSO9MRK58SE1K9	9.5	33.3	25.4
18	MSO18MPK58E1	MSO18MRK58E1	MSO18MPK58SE1K9	MSO18MRK58SE1K9	15.2	65.8	57.9
34	MSO34MPK58E1	MSO34MRK58E1	MSO34MPK58SE1K9	MSO34MRK58SE1K9	19.0		
50	MSO50MPK58E1	MSO50MRK58E1	MSO50MPK58SE1K9	MSO50MRK58SE1K9	18.9		
75	MSO75MPK58E1	MSO75MRK58E1	MSO75MPK58SE1K9	MSO75MRK58SE1K9	19.4		

For other platings: See plating table.

Other solder tail lengths on request

Selective loading on request

New



Right angle boardmount with guiding hardware (MSO--M-G1--)

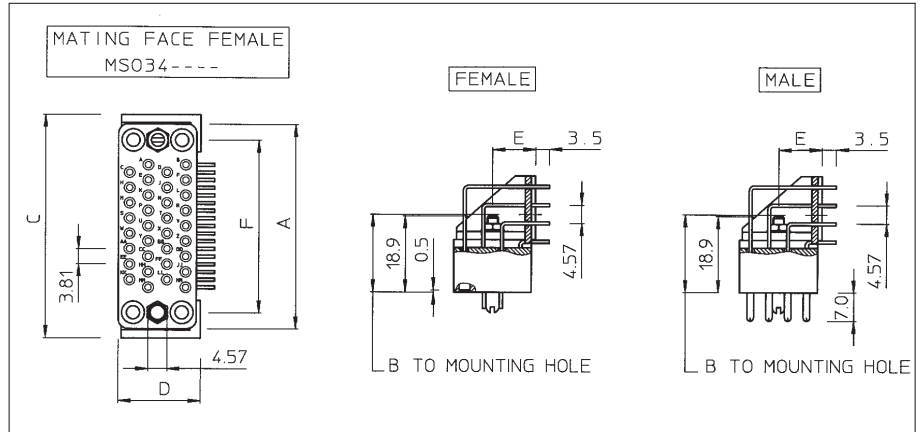
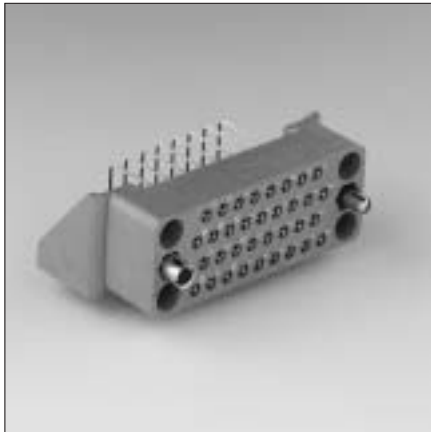

connector size	Part number				A	B	C	D	E	F
	Version with solid machined contacts		Version with stamped and formed contacts							
	male	female	male	female						
9	MSO9MPG1E1	MSO9MRG1E1			33.3	23.0	38.0	16.0	10.0	25.4
18	MSO18MPG1E1	MSO18MRG1E1						18.0		
34	MSO34MPG1E1	MSO34MRG1E1	MSO34MPG1SE1K9	MSO34MRG1SE1K9	50.8	19.3	55.5	20.5	10.5	42.8

For other platings: See plating table.

Other solder tail lengths on request

Selective loading on request

New

Right angle boardmount with jackscrew hardware (MSO--M-G58--)

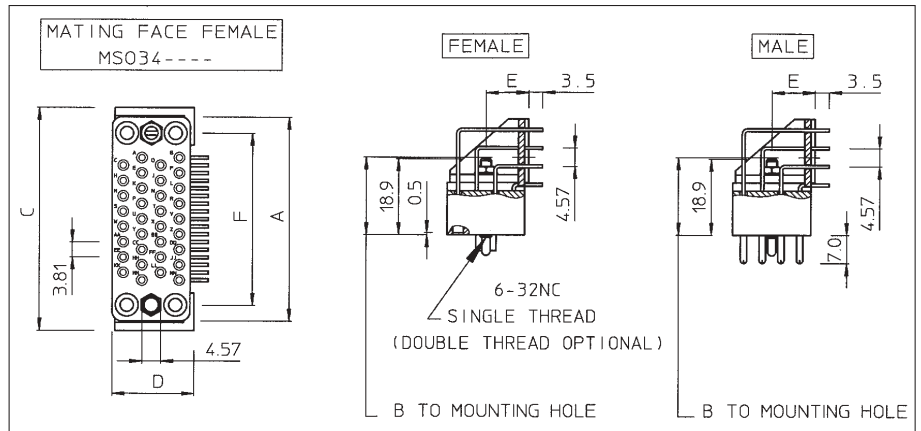
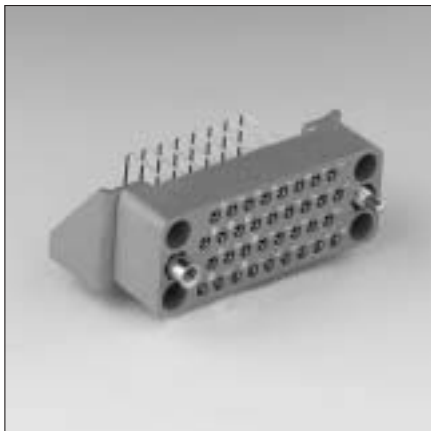

connector size	Part number				A	B	C	D	E	F
	Version with solid machined contacts		Version with stamped and formed contacts							
	male	female	male	female						
9	MSO9MPG58E1	MSO9MRG58E1			33.3	23.0	38.0	16.0	10.0	25.4
18	MSO18MPG58E1	MSO18MRG58E1						18.0		
34	MSO34MPG58E1	MSO34MRG58E1	MSO34MPG58SE1K9	MSO34MRG58SE1K9	50.8	19.3	55.5	20.5	10.5	42.8

For other platings: See plating table.

Other solder tail lengths on request

Selective loading on request

New



MSO recommended drilling hole pattern

Size 9

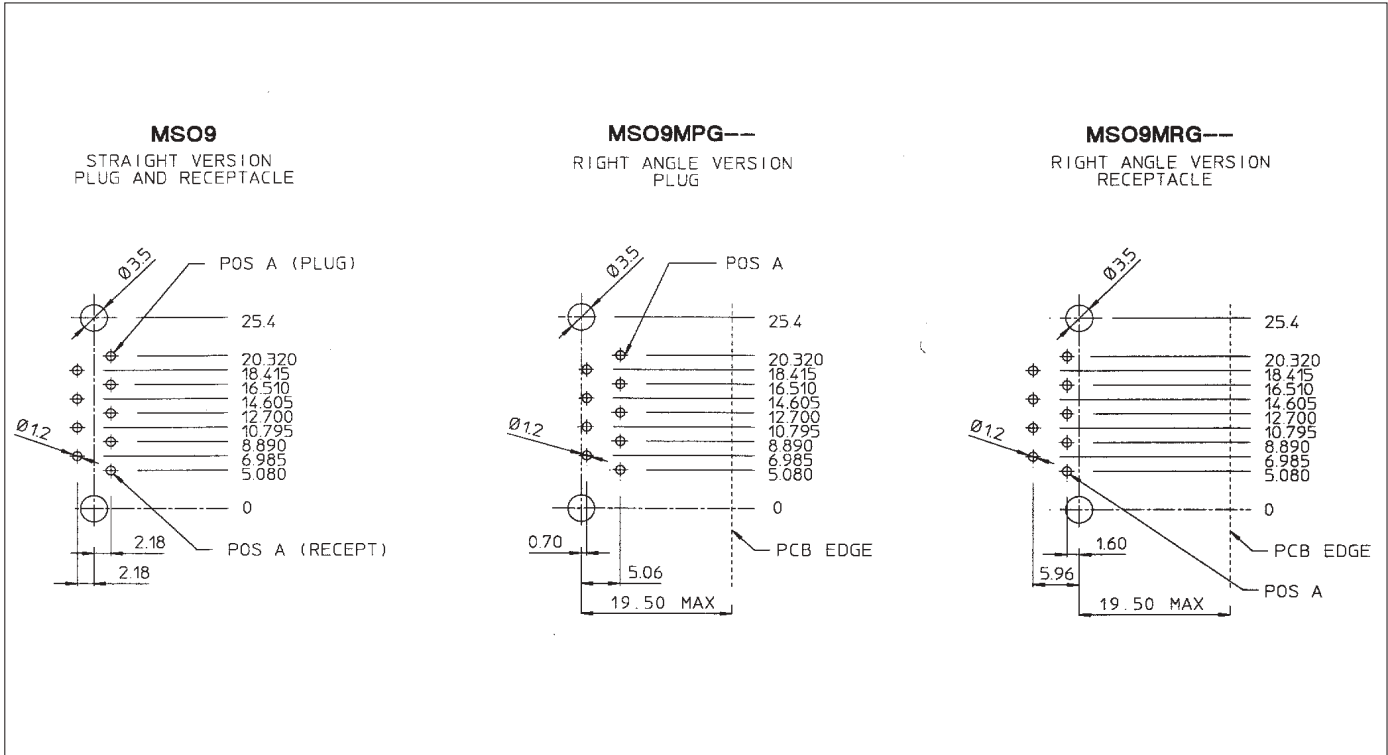

Size 18

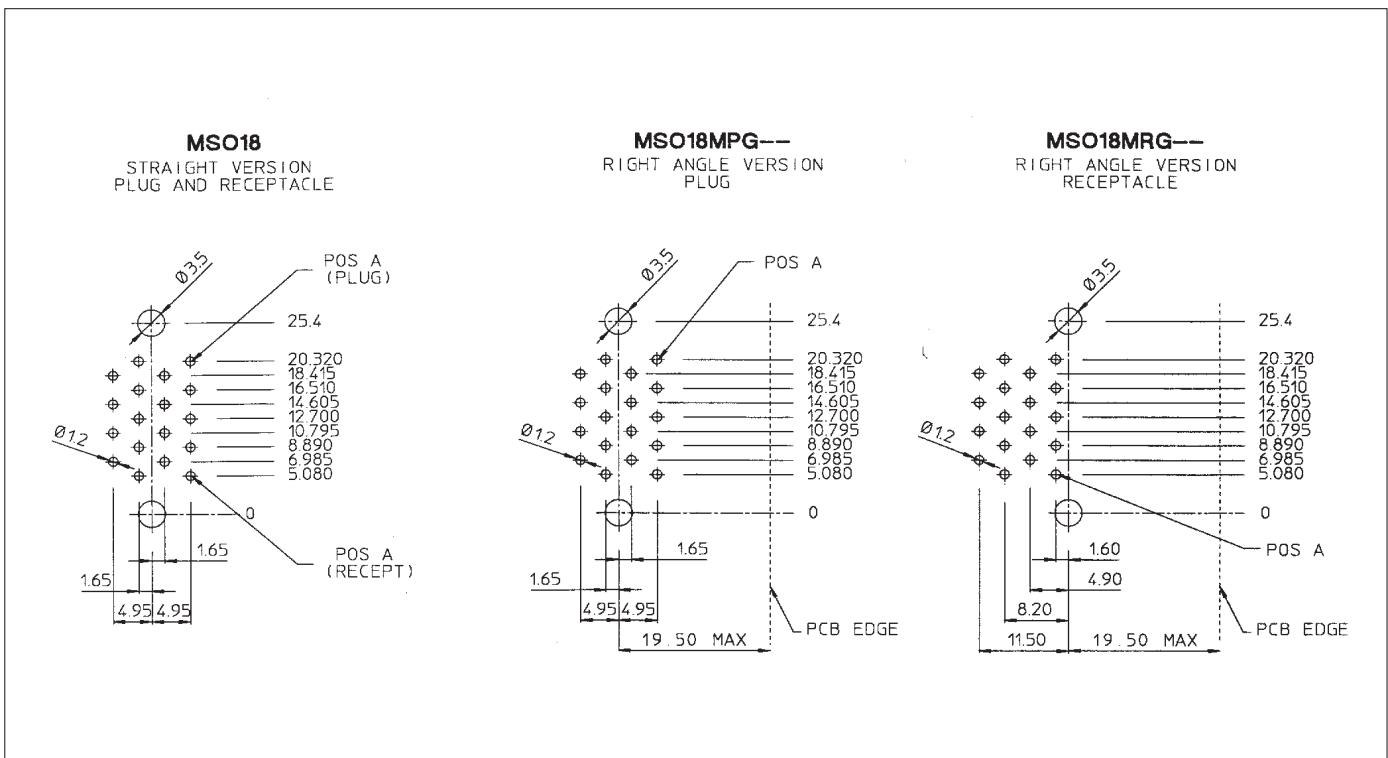



MSO recommended drilling hole pattern

Size 34

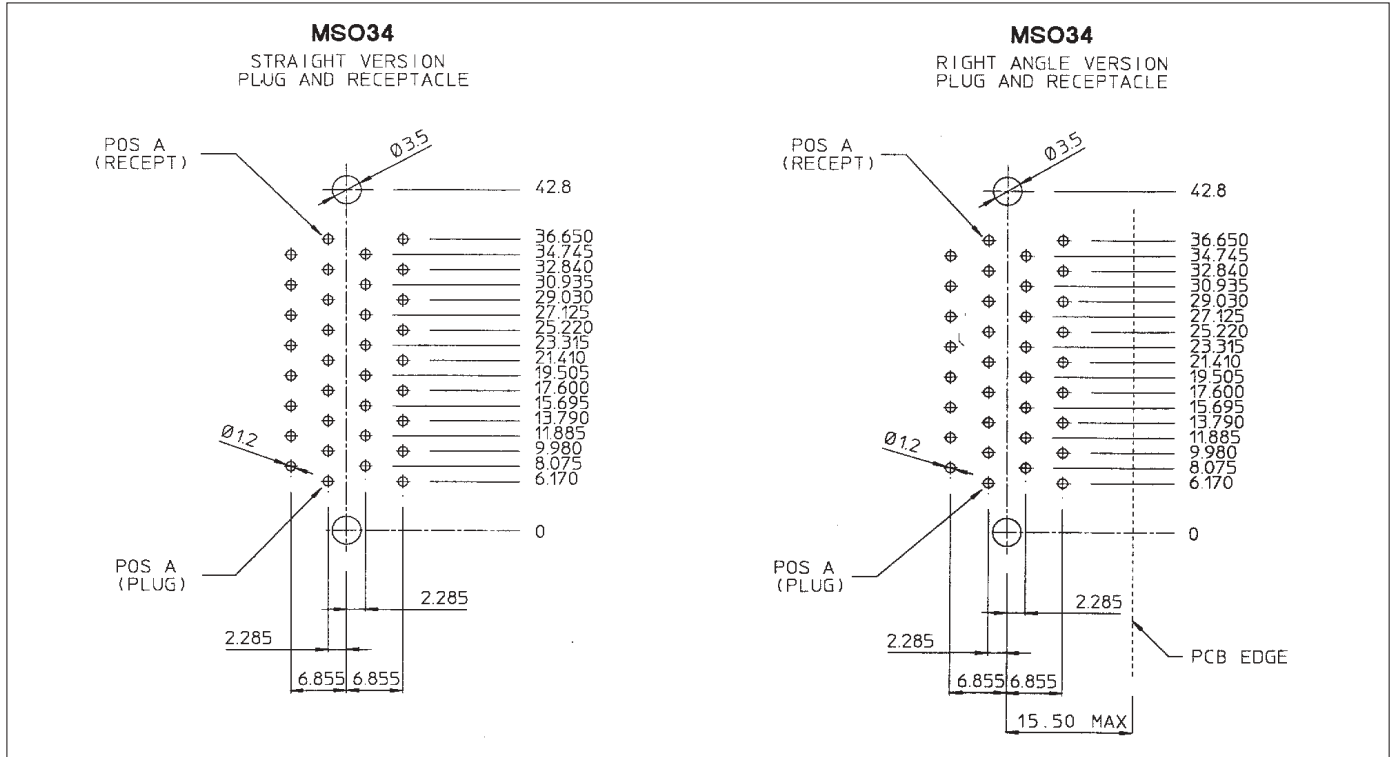

Size 50

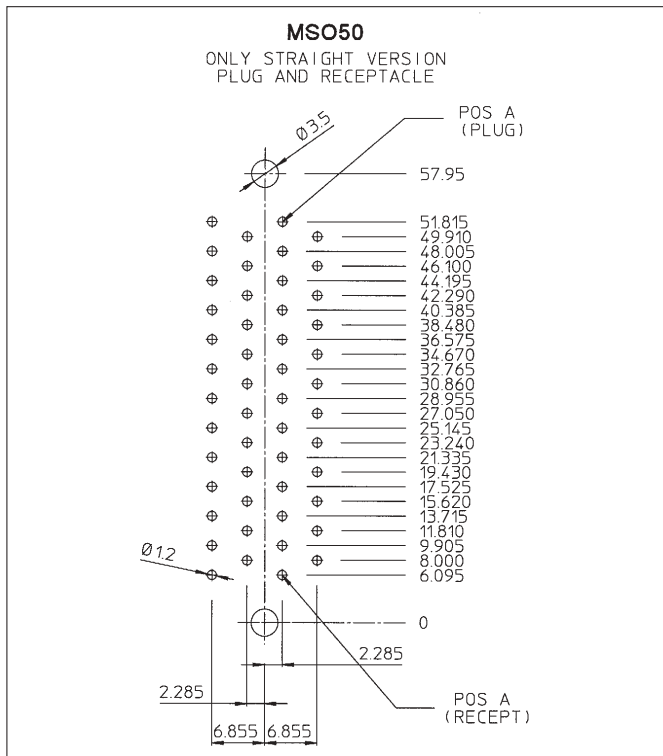

Size 75

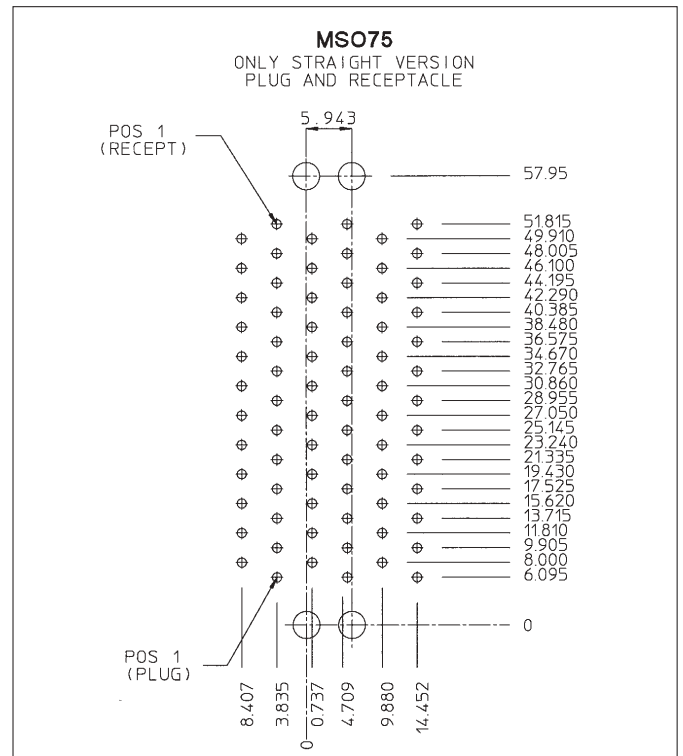



V.35 DTE/DCE Interface connectors

Description

The Telecommunications Standardization Sector TSS V.35, formerly CCITT V.35 is the international standard termed "Data Transmission at 48 Kbps using 60-108 Khz Group-Band Circuits. It makes use of a 34 contact connection system specially designed to be used for DTE/DCE that interface to high speed digital carriers found in computer, modem and telecommunication industries.

Being part of the TRIM TRIO wide range of high reliable rectangular connectors, **MSO34** (boardmount connectors) and **MS34** (cable connectors) are in complete compliance to this specification.

To meet this specification, insulators have been manufactured with 34 contact positions which can be loaded with the international accepted N° 16 TRIM TRIO .0625" (1.6mm) diameter contacts.

The boardmount connectors (**MSO34**) are available in straight and right angle versions equipped with either solid machined or stamped and formed male / female contacts.

Filtered connectors are under development.

The cable connectors (**MS34**) can be offered with a full range of hardware and accessories. Guiding pins and sockets, turnable jackscrew system, different cable hoods with strain relief, pin protection shrouds and discrimination pins make this connector range as complete as possible.

Features and benefits

- Complete compliance with International Standards of ISO 2593 for TSS V.35 (formerly CCITT V.35) interfacing.
- In compliance with NFC 93426 - HE621-622 and MIL-C-28748 specifications.
- UL recognised.
- UL94-V0 rated thermoplastic
- Boardmount connectors supplied pre-assembled with dipsolder contacts in either:
 - Male or female contacts.
 - Machined or stamped and formed contacts
 - Straight or right-angled
- Stamped and formed contacts have selective tin plating on solder tails, thus eliminating extra flux operations.
- *Selective loading possible on request.*
- Filtered versions are under development.

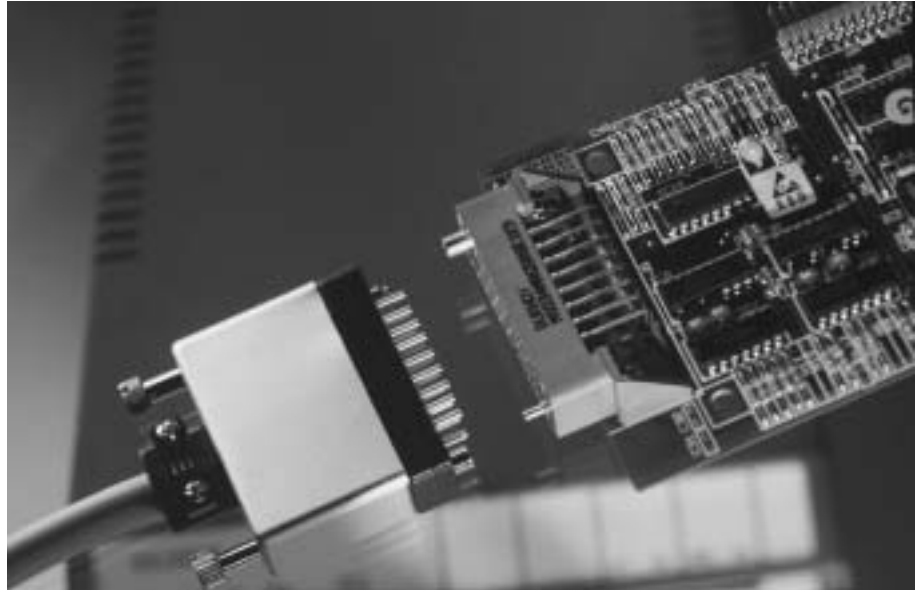

Intermateability

All the references mentioned are perfectly intermateable, provided that 1 mated pair exists out of a plug half and a receptacle half.

Mated pairs can be made for following applications:

- Cable to cable
- Cable to panel
- Cable to straight or right-angled boardmount

Technical data on MSO34 PC-Boardmount connectors

Performance characteristics

Operating temperature:	-55°C to +125°C
Current rating:	7.5 Amp
Contact resistance:	≤ 3mΩ
Operating voltage:	750 V RMS
Insulation resistance:	5000 MΩ min.
Test potential:	2000 VAC
Durability:	500 matings and unmatings.

Plating table

Plating for solid machined contacts:	
No digit (std)	= Min. 0.4μ Gold all over, over Nickel.
J	= Gold flash all over, over Nickel.
T	= 3 - 5μ Tin all over
Plating for Stamped and formed contacts :	
K9 (std)	= Min. 0.4μ Gold in contact area, 3 - 5μ SnPb on solder tail.
T	= 3 - 5μ Tin all over

Construction

Material : Glass-reinforced thermoplastic
 Flammability rating : UL94-V0
 Polarising hardware: Brass nickel plated
 Contacts: High conductive copper alloy

Technical data on MS34 Cable connectors

Performance characteristics

Operating temperature:	-55°C to +125°C
Insulation resistence:	5000 MΩ min.
Test potential:	2000 VAC
Durability:	500 matings and unmatings.
Vibration resistance:	Per MIL-STD 202 method 204
Shock:	Per MIL-STD 202 method 207

Contact accommodation

- "MS" Cable connectors accept Trim Trio crimp-type removable snap-lock contacts
- Contacts to be ordered separately

Construction

Connector body: Glass-reinforced Phenolic
 Flammability rating : UL94-V0
 Cable hoods: Aluminium alloy or Polyamide 6.6
 Cable clamps: Stainless steel
 Protection Shrouds: Aluminium alloy
 Polarising hardware: Brass nickel plated



MSO34 Straight boardmount connectors

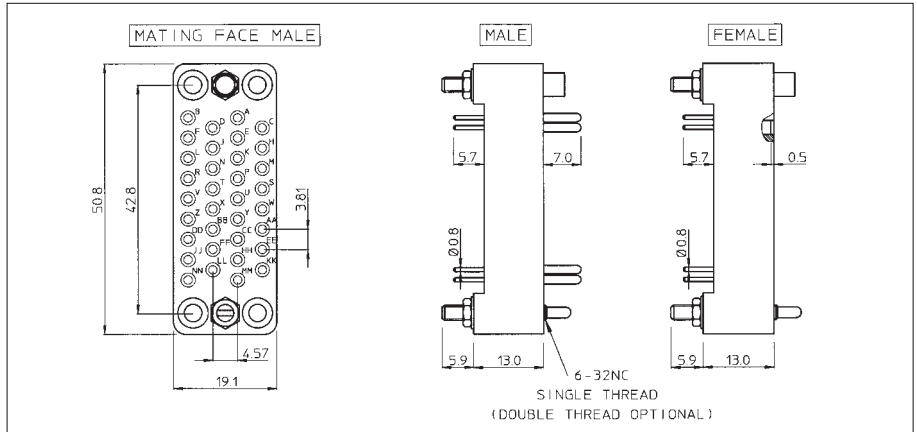

Part number		Description
Version with solid machined contacts	Version with stamped and formed contacts	
MSO34MPK1E1	MSO34MPK1SE1K9	Guide pin, guide socket and male contacts
MSO34MRK1E1	MSO34MRK1SE1K9	Guide pin, guide socket and female contacts
MSO34MPK58E1	MSO34MPK58SE1K9	Jackscrew pin, jackscrew socket and male contacts
MSO34MRK58E1	MSO34MRK58SE1K9	Jackscrew pin, jackscrew socket and female contacts

For other platings: See plating table

New

Other solder tail lengths on request

Selective loading on request

MSO34 Right-angled boardmount connectors

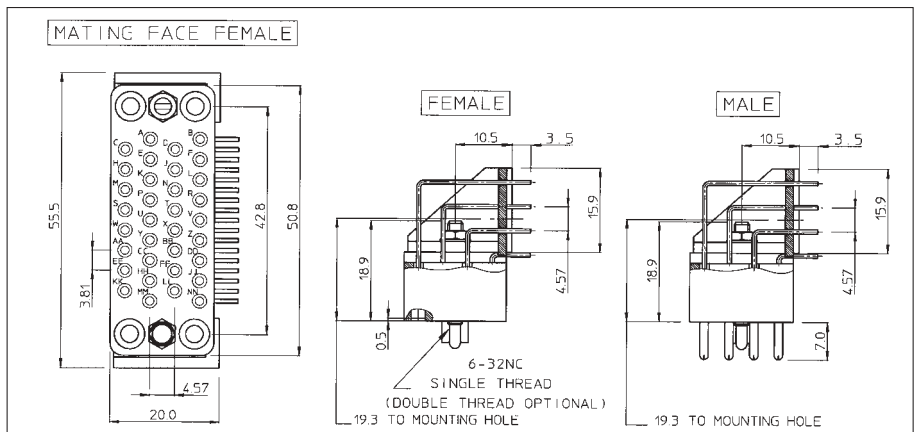
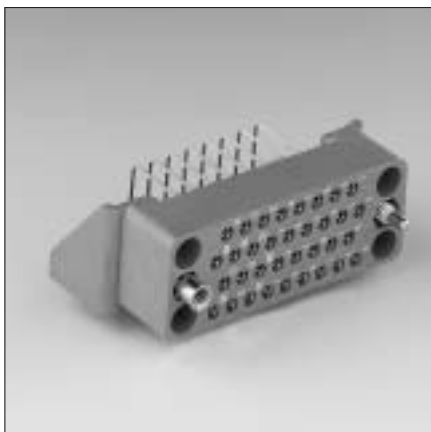

Part number		Description
Version with solid machined contacts	Version with stamped and formed contacts	
MSO34MPG1E1	MSO34MPG1SE1K9	Guide pin, guide socket and male contacts
MSO34MRG1E1	MSO34MRG1SE1K9	Guide pin, guide socket and female contacts
MSO34MPG58E1	MSO34MPG58SE1K9	Jackscrew pin, jackscrew socket and male contacts
MSO34MRG58E1	MSO34MRG58SE1K9	Jackscrew pin, jackscrew socket and female contacts

For other platings: See plating table

New

Other solder tail lengths on request

Selective loading on request



New

MSO34 Shielded right-angle boardmount connectors (under development)

For availability consult factory

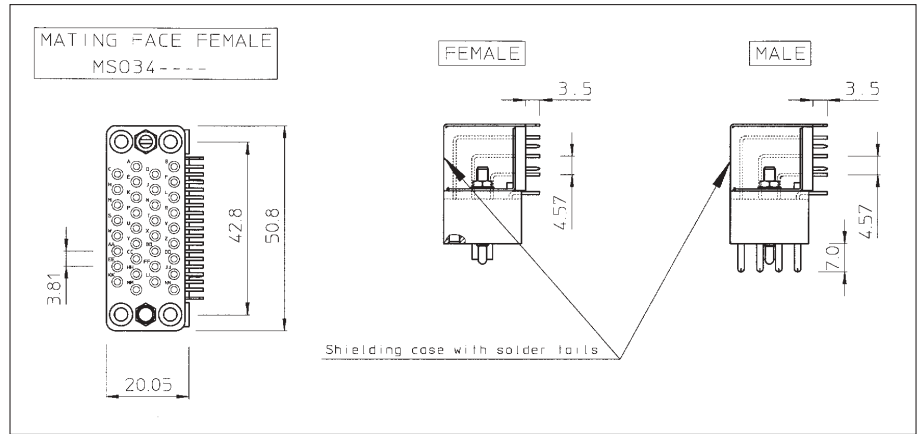

Under development



MS34 Cable connectors without strain relief hood

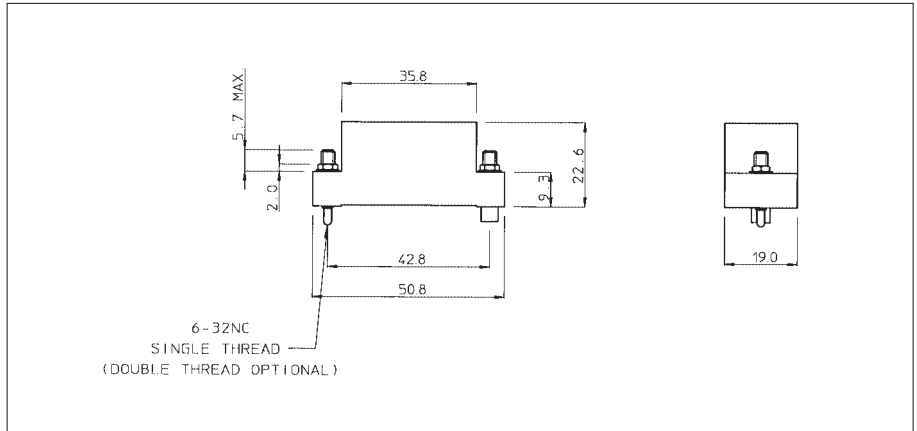

Part number		Description
Version with male contacts	Version with female contacts	
MS34PM1(*)GE00	MS34RM1(*)GE00	Guide pin and guide socket. No strain relief hood.
MS34PM58(*)GE00	MS34RM58(*)GE00	Jackscrew pin and jackscrew socket. No strain relief hood.
MS34PM007(*)GE00	MS34RM007(*)GE00	Turnable jackscrew pin and turnable jackscrew socket. No strain relief hood.

(*) Complete catalogue number with " S " for connector with protective shroud.

MS34 Cable connectors with cable clamp

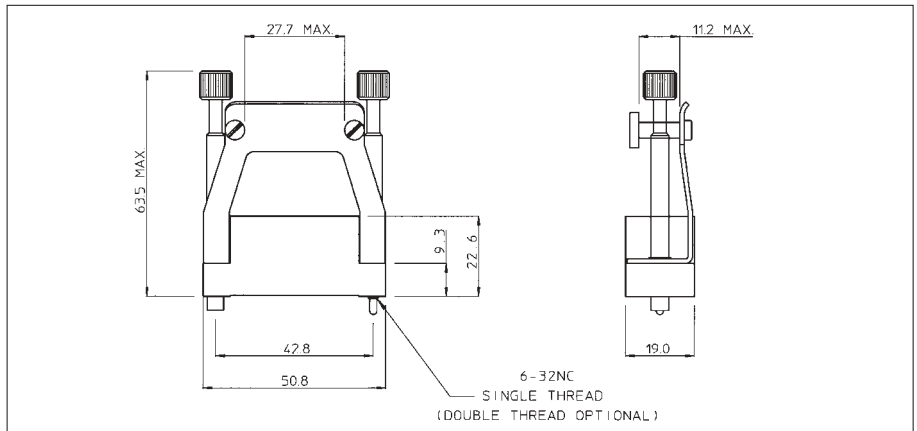

Part number		Description
Version with male contacts	Version with female contacts	
MS34PM117(*)GE00	MS34RM117(*)GE00	Guide pin, guide socket and cable clamp
MS34PM127(*)GE00	MS34RM127(*)GE00	Jackscrew pin, jackscrew socket and cable clamp
MS34PM107(*)GE10	MS34RM107(*)GE10	Turnable jackscrew pin, turnable jackscrew socket and cable clamp.

(*) Complete catalogue number with "S" for connector with protective shroud.



MS34 Cable connectors with metal butterfly hood

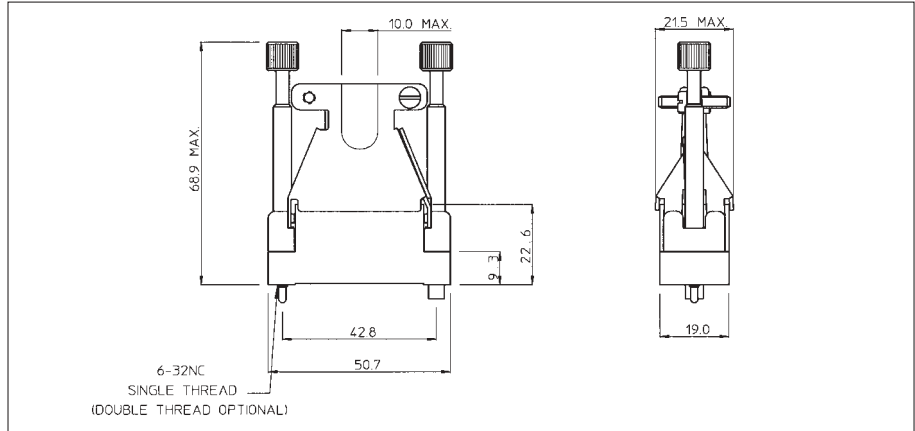

Part number		Description
Version with male contacts	Version with female contacts	
MS34PM120(*)GE00	MS34RM120(*)GE00	Guide pin, guide socket and butterfly hood
MS34PM140(*)GE00	MS34RM140(*)GE00	Jackscrew pin, jackscrew socket and butterfly hood.
MS34PM124(*)GE16	MS34RM124(*)GE16	Turnable jackscrew pin, turnable jackscrew socket and butterfly hood.

(*) Complete catalogue number with "S" for connector with protective shroud.

MS34 Cable connectors with plastic suitcase hood

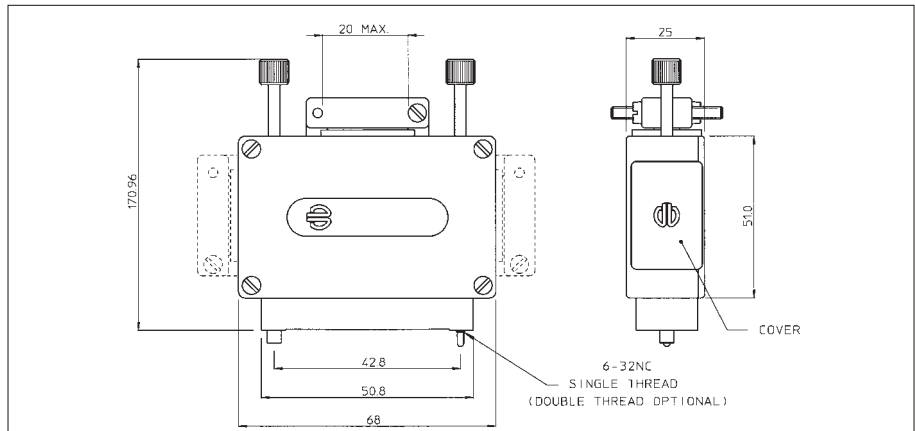

Part number		Description
Version with male contacts	Version with female contacts	
MS34PMEH2(*)	MS34RMEH2(*)	Guide pin, guide socket and plastic suitcase hood.
MS34PMEH3(*)	MS34RMEH3(*)	Jackscrew pin, jackscrew socket and plastic suitcase hood.
MS34PMEH0(*)	MS34RMEH0(*)	Turnable jackscrew pin, turnable jackscrew socket and plastic suitcase hood.

(*) Complete catalogue number with "S" for connector with protective shroud.



New

MS34 Cable connector with metal suitcase hood

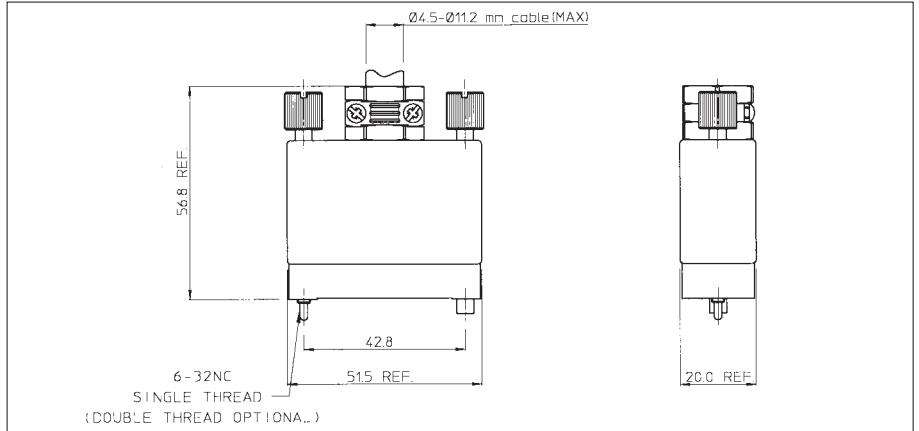

Part number		Description
Version with male contacts	Version with female contacts	
MS34PMEHM(*)	MS34RMEHM(*)	Anodised hood, plastic strain relief and turnable hardware
MS34PMSEHM(*)	MS34RMSEHM(*)	Shielded version with nickel plated hood, metal strain relief and turnable hardware

(*) Complete catalogue number with " S " for connector with protective shroud.

Contacts arrangement for cable connectors

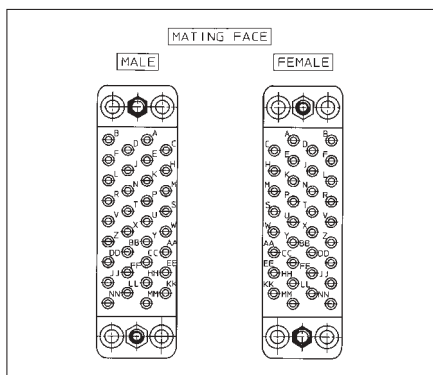

Panel cut-out for cable connectors

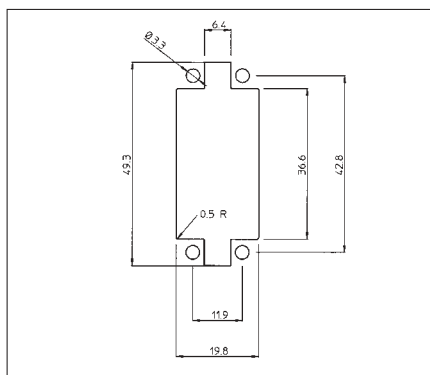

Recommended PCB drilling hole pattern for MSO34

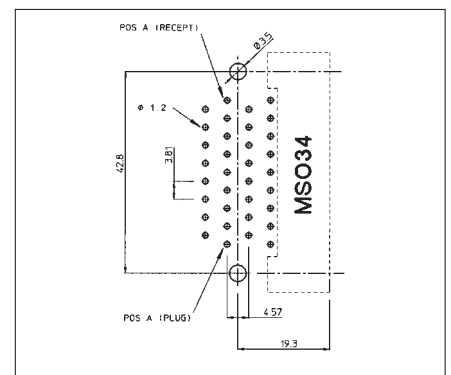



Qikmate panel and cable connectors

Description

The versatile “ SMS “ Qikmate panel and cable connectors are a highly cost-effective system approach to solving the constant demand for more cost effective interconnection techniques.

It is a range of multiway connectors using N° 16 TRIM TRIO .0625” (1.6mm) diameter contacts and available in 10 contact arrangements from 2 to 36 positions. Having no additional hardware, Panel receptacle connectors snap and lock into panel cutouts and cable plugs quick connect and disconnect with positive retention locks.

Cable plug connectors also feature pin-protection skirts, positive polarisation and can be supplied with or without integrated strain relief hoods.

Cable receptacle connectors (only with integrated strain relief hood) are developed to mate with cable plug connectors thus offering solutions for cable to cable applications.

Features and benefits

- Available in 10 contact arrangements.
- Self mountable panel receptacle with positive housing retention.
- Cable plugs with retaining latches for positive locking.
- Cable plug has pin protection skirt to prevent damage of male contacts
- Positive polarization keys prevent mismatching.
- Cable plug and receptacle have integrated strain relief hood which can take a wide range of cables.
- Cable plug and receptacle have discrimination cavities in between contact cavities, thus offering discrimination without contact loss.

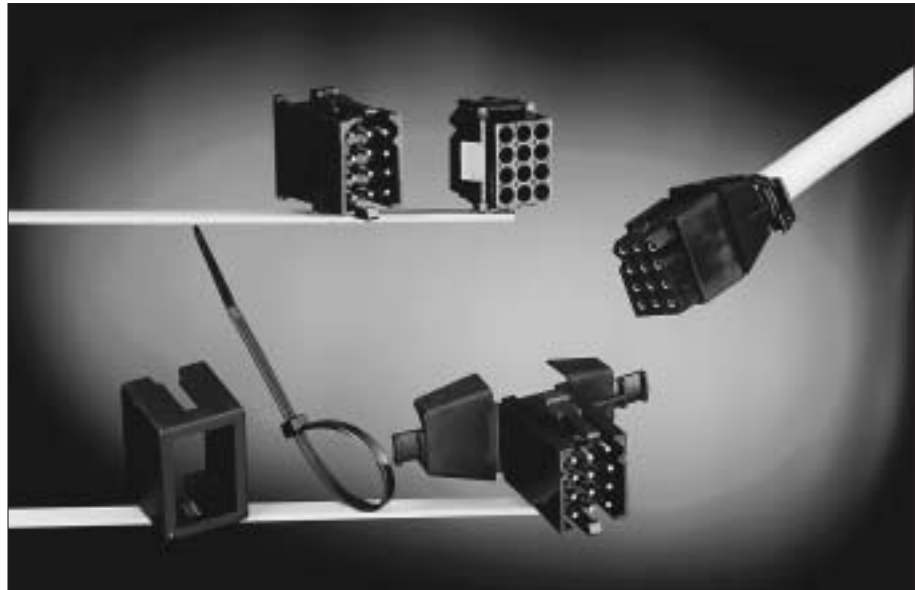

Performance characteristics

Operating temperature:	-55°C to +105°C
Insulation resistance:	5000 M min.
Test potential:	2000 VAC
Durability:	500 matings and unmatings.

Construction

Material :	Polyamide 6.6
Flammability rating :	UL94-V2

Contact accommodation

- “SMS” Qikmate connectors accept Trim-Trio crimp-type removable snap-lock contacts (see contact section)
- Contacts to be ordered separately.

How to order

Connector family	SMS	12	PDH1
Contact arrangement			
Body variation:	R1: Panel mount receptacle		
	P1: Cable plug without strain relief hood		
	PDH1: Cable plug with integrated strain relief hood		
	RDH1: Cable receptacle with integrated strain relief hood		



Contact arrangements for cable plug connectors (SMS--P1 and SMS--PDH1)

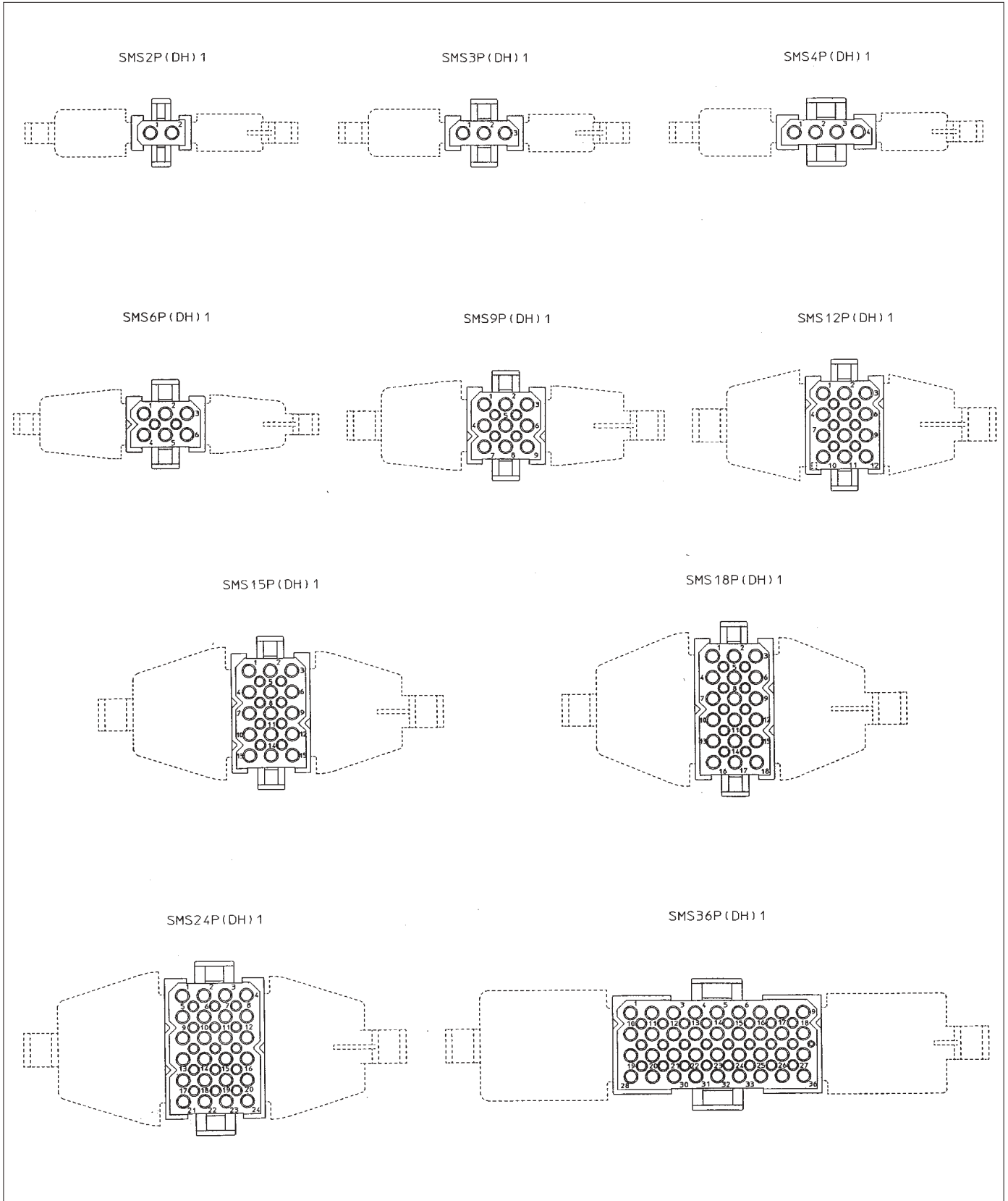

Contact identifications shown are for mating face. Contact identifications of wiring face are identical as shown on the receptacle arrangements



Contact arrangements for cable and panel mount receptacle connectors (SMS--R1 and SMS--RDH1)

SMS2R(DH) 1

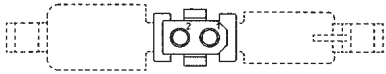

SMS3R(DH) 1

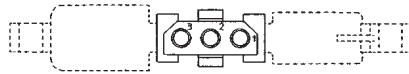

SMS4R(DH) 1

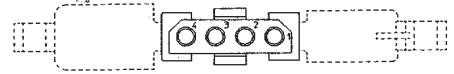

SMS6R(DH) 1

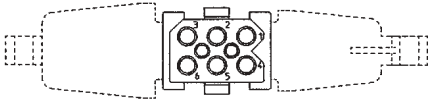

SMS9R(DH) 1

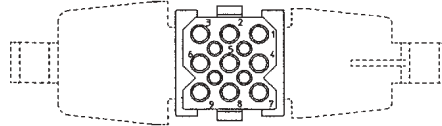

SMS12RDH1

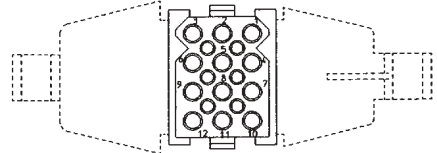

SMS15R(DH) 1

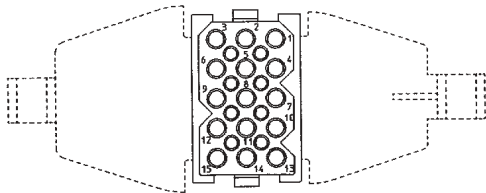

SMS18R(DH) 1

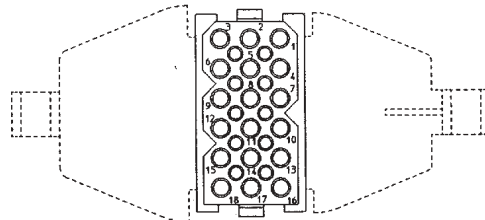

SMS24R(DH) 1

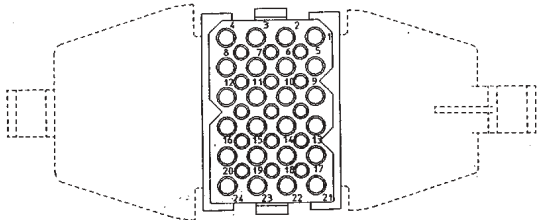

SMS36R(DH) 1

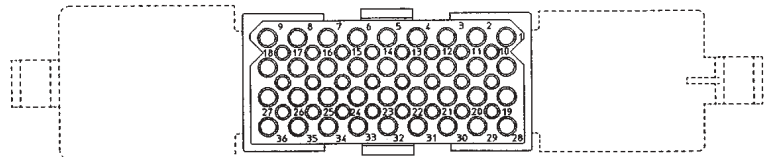

Contact identifications shown are for mating face. Contact identifications of wiring face are identical as shown on the plug arrangements



SMS - Standard Qikmate intermateability chart

INTERMATEABILITY

SMS--PDH1
(PLUG WITH MOULDED
ON CABLE HOODS)

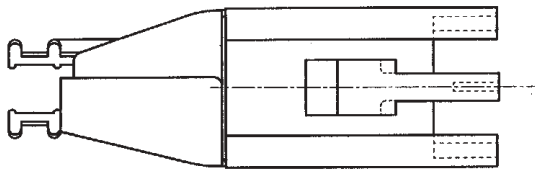

SMS--P1
(PLUG WITHOUT MOULDED
ON CABLE HOODS)

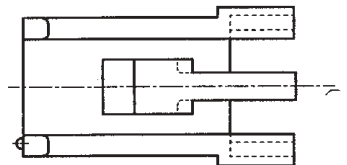

SMS--RDH1
(RECEPTACLE WITH MOULDED
ON CABLE HOODS)

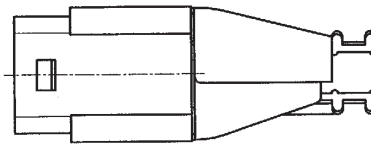

STRAIGHT BOARDMOUNT
FEMALE

SMS--GE3 MACHINED CONTACT

SMS--R/SE3 STAMPED CONTACT

MALE

SMS--GE4 MACHINED CONTACT

SMS--R/SE4 STAMPED CONTACT

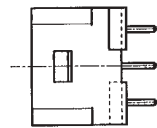

RIGHT ANGLE BOARDMOUNT
FEMALE

SMS--GE5 MACHINED CONTACT

SMS--SE5 STAMPED CONTACT

MALE

SMS--GE6 MACHINED CONTACT

SMS--SE6 STAMPED CONTACT

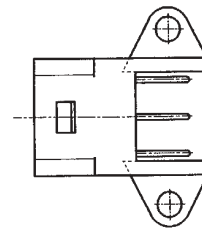

(ONLY IN SIZES
3, 6, 12 AND 18)

SMS--R-1
(PANEL MOUNT
RECEPTACLE)

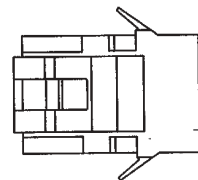



Panel mount receptacle (SMS--R1)

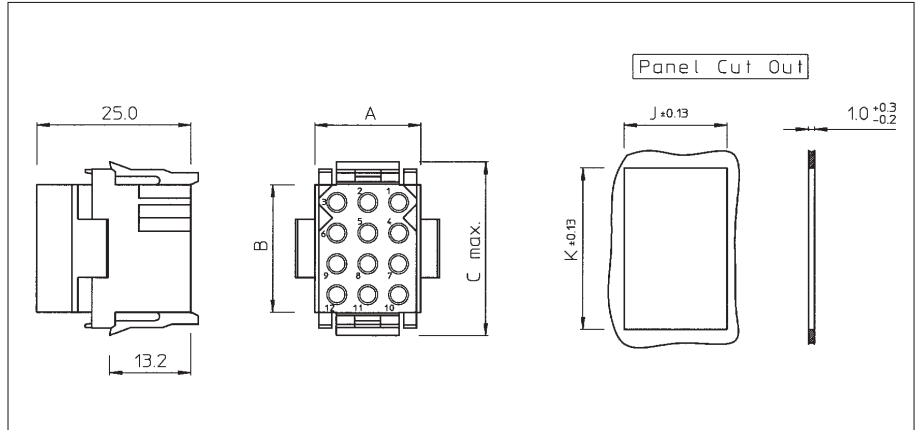

Part number	Number of contact pos.	A	B	C max.	J ±0.13	K ±0.13
SMS2R1	2	11.0	5.8	15.2	11.4	11.6
SMS3R1	3	16.2			16.5	
SMS4R1	4	21.2			21.7	
SMS6R1	6	16.2	10.9	20.3	16.5	16.7
SMS9R1	9		16.0	25.4	16.7	21.6
SMS12R1	12		21.1	30.5		26.7
SMS15R1	15		26.2	35.6		31.8
SMS18R1	18		31.2	40.6	36.9	
SMS24R1	24		21.2		21.7	
SMS36R1	36	46.6	21.1	30.5	47.1	26.7

Cable plug without strain relief hood (SMS--P1)

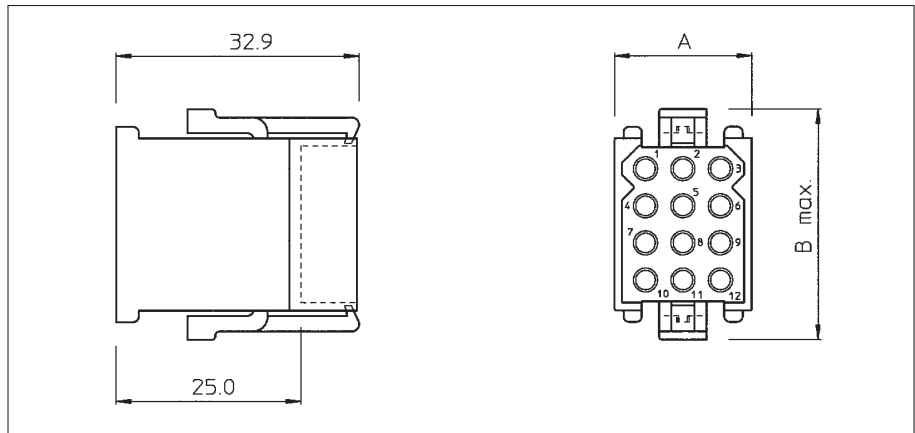

Part number	Number of contact pos.	A	C max.
SMS2P1	2	15.0	17.8
SMS3P1	3	18.6	
SMS4P1	4	23.7	
SMS6P1	6	18.6	22.9
SMS9P1	9		27.9
SMS12P1	12		33.0
SMS15P1	15		38.1
SMS18P1	18		43.2
SMS24P1	24		23.7
SMS36P1	36	49.1	33.0



New

Cable receptacle with integrated strain relief hood (SMS--RDH1)

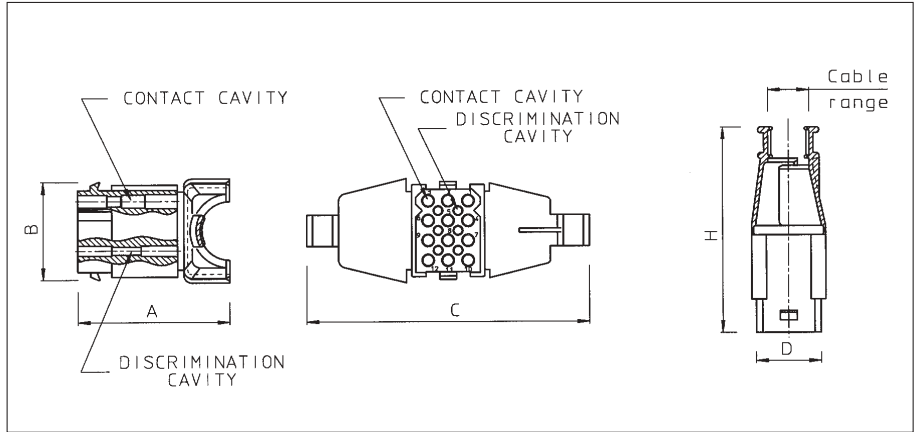

Part number	Number of contact pos.	Number of discrimination pos.	A	B	C	D	H	Cable range	Recommended unirap cable te
SMS2RDH1	2	0	31.6	9.9	64.8	11.1	49..2	0.5 - 8.4	TF4BKD
SMS3RDH1	3	0	35.1		69.0	16.2		0.8 - 7.3	
SMS4RDH1	4	0	38.2		74.4	21.2		1.5 - 10.0	
SMS6RDH1	6	2	34.6	15.0	72.6	16.2	50.9	1.7 - 9.2	TF5BKD
SMS9RDH1	9	4	35.8	20.0	75.3		52.2	3.9 - 14.3	
SMS12RDH1	12	6	38.1	25.1	72.0		52.7	4.0 - 15.0	
SMS15RDH1	15	8	35.9	30.2	81.3	21.2	55.2	5.0 - 16.2	TF5BKD
SMS18RDH1	18	10	36.1	35.3	90.4		57.2	5.8 - 20.3	
SMS24RDH1	24	15	39.7	90.4			57.2	7.1 - 20.4	
SMS36RDH1	36	24	54.6	25.1	128.0	46.6	63.3	8.8 - 24.5	

Cable plug with integrated strain relief hood (SMS--PDH1)

New

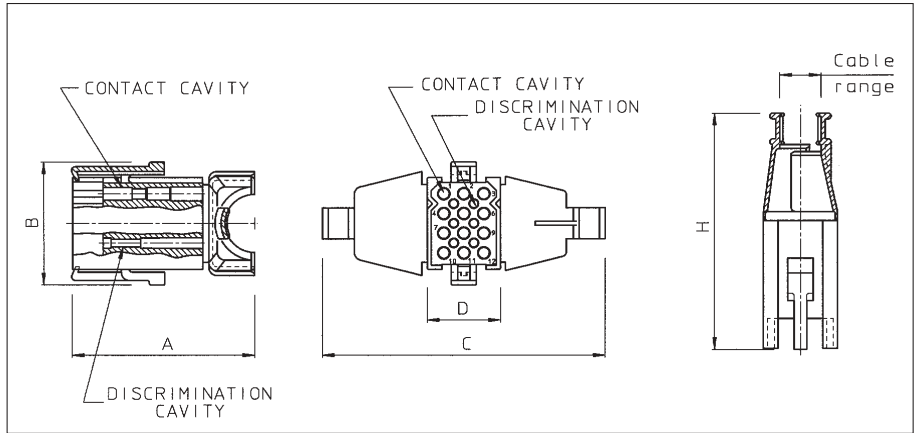

Part number	Number of contact pos.	Number of discrimination pos.	A	B	C	D	H	Cable range	Recommended unirap cable te
SMS2PDH1	2	0	39.5	16.4	64.8	14.1	57.1	0.5 - 8.4	TF4BKD
SMS3PDH1	3	0	43.0		69.0	18.6		0.8 - 7.3	
SMS4PDH1	4	0	46.1		74.4	23.7		1.5 - 10.0	
SMS6PDH1	6	2	42.5	21.5	72.6	18.6	58.8	1.7 - 9.2	TF5BKD
SMS9PDH1	9	4	43.7	26.7	75.3		60.1	3.9 - 14.3	
SMS12PDH1	12	6	46.0	31.7	72.0		60.6	4.0 - 15.0	
SMS15PDH1	15	8	43.8	36.7	81.3	23.7	63.1	5.0 - 16.2	TF5BKD
SMS18PDH1	18	10	44.0	41.8	90.4		65.1	5.8 - 20.3	
SMS24PDH1	24	15	47.6	90.4			65.1	7.1 - 20.4	
SMS36PDH1	36	24	62.5	31.7	128.0	49.1	71.2	8.8 - 24.5	



Accessories for standard Qikmate connectors

Pin protection shroud for panel mount receptacle (SMS--CSB1)

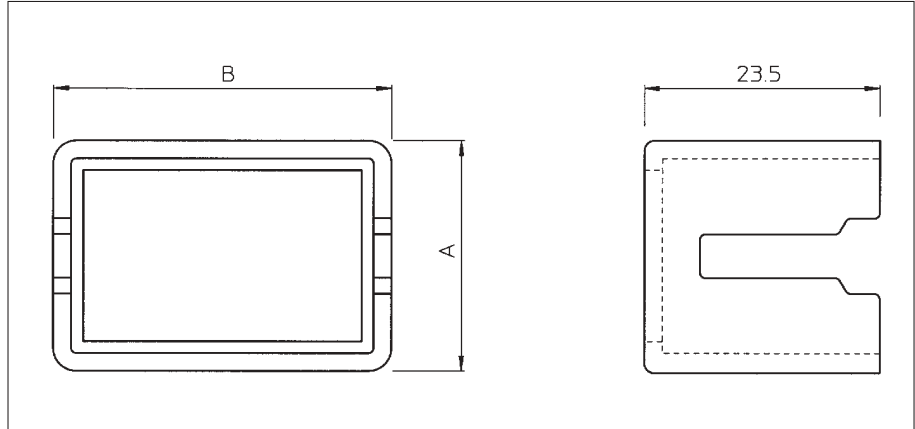

When pins are inserted into the panelmount receptacle half (SMS--R1) of the QIKMATE connector, an optional pin protection shroud can be installed.

The shroud is mounted at the same time as the receptacle by holding the shroud against the mating side of the panel with both cutouts lined up. The receptacle is then inserted in place, trapping the shroud between the receptacle and panel. The use of the pin protection shroud reduces the allowable thickness of the panel from 2.3 to 1.6 mm max.

Part number	Number of contact positions	A	B
SMS2CSB1	2	19.8	18.8
SMS3CSB1	3	23.4	
SMS4CSB1	4	28.4	
SMS6CSB1	6	23.4	23.9
SMS9CSB1	9		29.0
SMS12CSB1	12		34.0
SMS15CSB1	15		39.1
SMS18CSB1	18		44.2
SMS24CSB1	24	28.4	
SMS36CSB1	36	54.1	34.0

Unirap cable tie

Unirap selflocking cable ties are designed per MIL - 23190E and guarantee permanent harness tying either by hand or with special TY501 tooling for pre-selected strap tighness.

Unirap is recommended to harness the integrated strain relief hoods on the QIKMATE cable receptacles and plugs

- **Construction**
black Polyamide 6.6 - UL94-V2
- **Operating Temperature**
-55°C to +100°C
- **Min tensile strength**
TF4BKD =180N TF5BKD =220N
- **Packing qty.** = 100 pcs. in plastic bag.



Discrimination pins

For discrimination pins on both standard Qikmate and Qikmate Pin Headers cable and boardmount:
See accessories section.



Qikmate PC-boardmount connectors

Description

These PC boardmount connectors enable QIKMATE and preassembled TRIM TRIO contacts to be PC board mounted, using conventional solder production techniques. They will then mate and latch with the standard QIKMATE plugs.

Straight boardmount QIKMATE is available in 10 insert arrangements from 2 to 36 positions.

Right-angled boardmount Qikmate is available in 3, 6, 12 and 18 positions.

All boardmount connectors are supplied fully loaded with pin or socket contacts, either in solid machined or stamped and formed contacts.

Stamped and formed contact have selective tin plating on the solder tails, thus eliminating flux operations.

Features and benefits

- Straight versions available in 10 contact arrangements from 2 to 36 positions
- Right-angled versions available in 3, 6, 12 and 18 positions.
- All versions are available with:
 - Pin or socket contacts
 - Stamped and formed or solid machined contacts.
- Some boardmount connectors have discrimination cavities in between contact cavities, thus offering discrimination without contact loss.



Performance characteristics

Operating temperature:	-55°C to +125°C
Insulation resistance:	5000 M min.
Test potential:	2000 VAC
Current rating:	5 Amp
Durability:	500 matings and unmatings.

Construction

Connector body:	Glass filled thermoplast UL94-V2
Contacts:	High conductive copper alloy

Plating table

Plating Table		
Plating Suffix	Description	Plating
TR-29	Tin-Alloy Pre-Plated	
D70	.000005 in (0.13 micron) Gold over .000075 in (1.9 micron) Nickel	Standard
S6	.000030 in (0.75 micron) .Gold over .000075 in (1.9 micron) Nickel	Selective

Intermateability

- “SMS” Qikmate boardmount connectors with preassembled TRIM TRIO boardmount contacts are intermateable only with the “SMS” Qikmate cable plug connectors equipped with TRIM TRIO crimp type removable snap-lock contacts (see contact section)

How to order

Connector family (Self Mountable System)	SMS	12	GE	3	-
	SMS	12	RE	3	
Contact arrangement					
Contact type:	GE: Solid machined contacts RE: Stamped and formed contacts				
Design variation:	3: Straight boardmount with female contacts 4: Straight boardmount with male contacts 5: Right angle boardmount with female contacts 6: Right angle boardmount with male contacts				
Plating indication					



New

Straight boardmount with female contacts (SMS--GE3 / SMS--RE3S6)

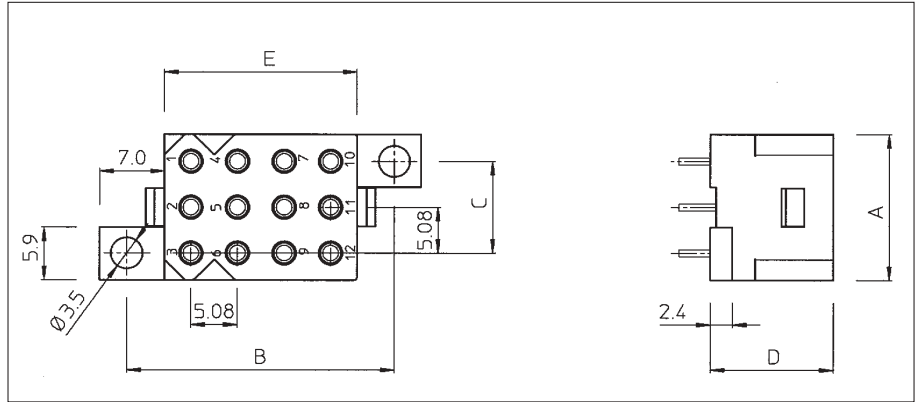

Part number Solid machined contacts	Part number Stamped and formed contacts	Number of contact pos.	Number of discrimination pos.	A	B	C	D	E
SMS2GE3	SMS2RE3S6	2	0	11.0	-	19.1	13.4	5.9
SMS3GE3	SMS3RE3S6	3	0	16.2	14.0	10.2		
SMS4GE3	SMS4RE3S6	4	0	21.3		15.2		
SMS6GE3	SMS6RE3S6	6	0	16.2	19.2	10.2		10.9
SMS9GE3	Not Available	9	4		24.2			16.0
SMS12GE3	SMS12RE3S6	12	0		29.2			21.1
SMS15GE3	Not Available	15	8		34.3			26.1
SMS18GE3	Not Available	18	10		39.4	31.2		
SMS24GE3	SMS24RE3S6	24	0	21.2		15.2		20.9
SMS36GE3	SMS36RE3S6	36	0	46.5	15.2	54.6		

For other platings: see plating table

Straight boardmount with male contacts (SMS--GE4 / SMS--RE4S6)

New

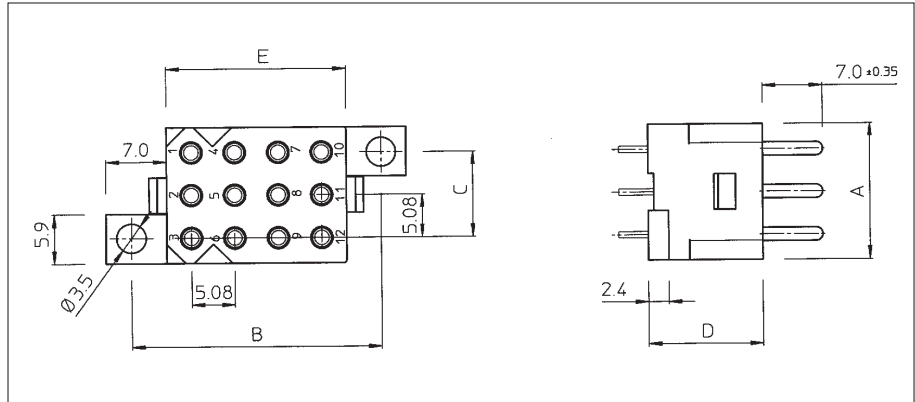

Part number Solid machined contacts	Part number Stamped and formed contacts	Number of contact pos.	Number of discrimination pos.	A	B	C	D	E
SMS2GE4	SMS2RE4S6	2	0	11.0	-	19.1	13.4	5.9
SMS3GE4	SMS3RE4S6	3	0	16.2	14.0	10.2		
SMS4GE4	SMS4RE4S6	4	0	21.3		15.2		
SMS6GE4	SMS6RE4S6	6	0	16.2	19.2	10.2		10.9
SMS9GE4	SMS9RE4S6	9	4		24.2			16.0
SMS12GE4	SMS12RE4S6	12	0		29.2			21.1
SMS15GE4	SMS15RE4S6	15	8		34.3			26.1
SMS18GE4	SMS18RE4S6	18	10		39.4	31.2		
SMS24GE4	SMS24RE4S6	24	0	21.2		15.2		20.9
SMS36GE4	SMS36RE4S6	36	0	46.5	15.2	54.6		

For other platings: see plating table



New

Right angle boardmount with female contacts (SMS--GE5 / SMS--SE5K9)

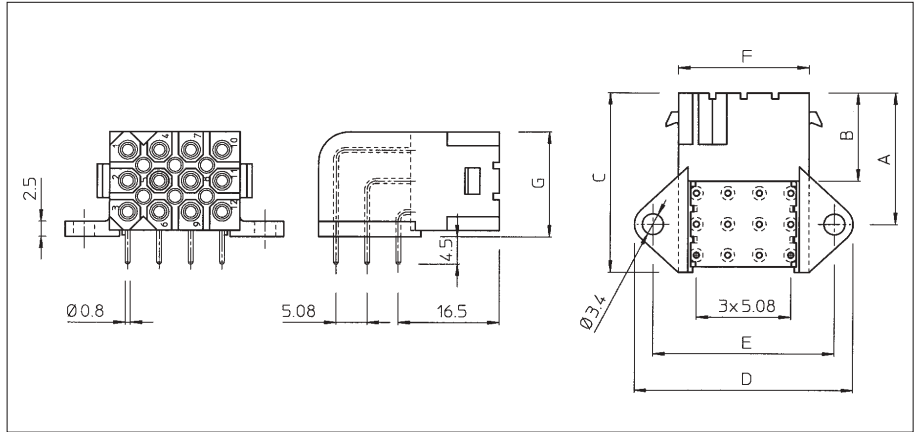

Part number Solid machined contacts	Part number Stamped and formed contacts	Number of contact pos.	Number of discrimination pos.	A	B	C	D	E	F	G
SMS3GE5	SMS3SE5K9	3	0	16.5	14.4	20.5	30.2	24.2	16.2	6.8
SMS6GE5	SMS6SE5K9	6	0	19.0		24.5	35.2	29.2	21.2	11.9
SMS12GE5	SMS12SE5K9	12	6	21.6		29.5				17.2
SMS18GE5	SMS18SE5K9	18	10			45.4	39.4	31.2		

For other platings: see plating table

SMS

Right angle boardmount with male contacts (SMS--GE6 / SMS--SE6K9)

New

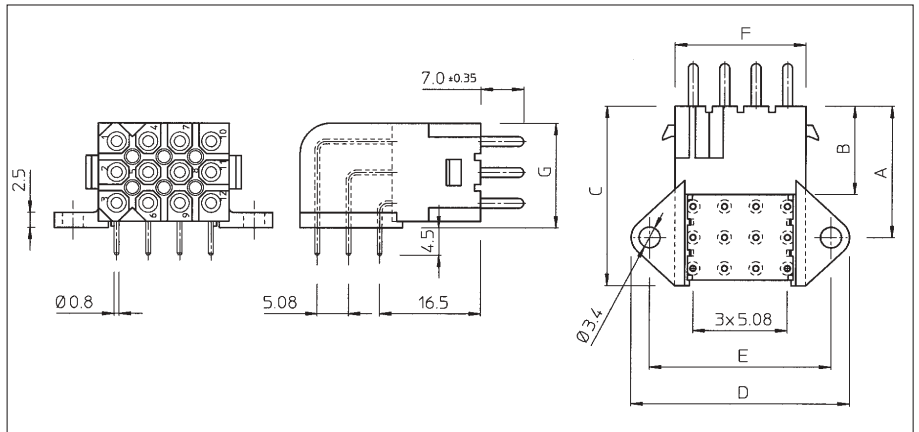

Part number Solid machined contacts	Part number Stamped and formed contacts	Number of contact pos.	Number of discrimination pos.	A	B	C	D	E	F	G
SMS3GE6	SMS3SE6K9	3	0	16.5	14.4	20.5	30.2	24.2	16.2	6.8
SMS6GE6	SMS6SE6K9	6	0	19.0		24.5	35.2	29.2	21.2	11.9
SMS12GE6	SMS12SE6K9	12	6	21.6		29.5				17.2
SMS18GE6	SMS18SE6K9	18	10			45.4	39.4	31.2		

For other platings: see plating table



Recommended PC-Board hole lay out for straight male and female boardmount connectors

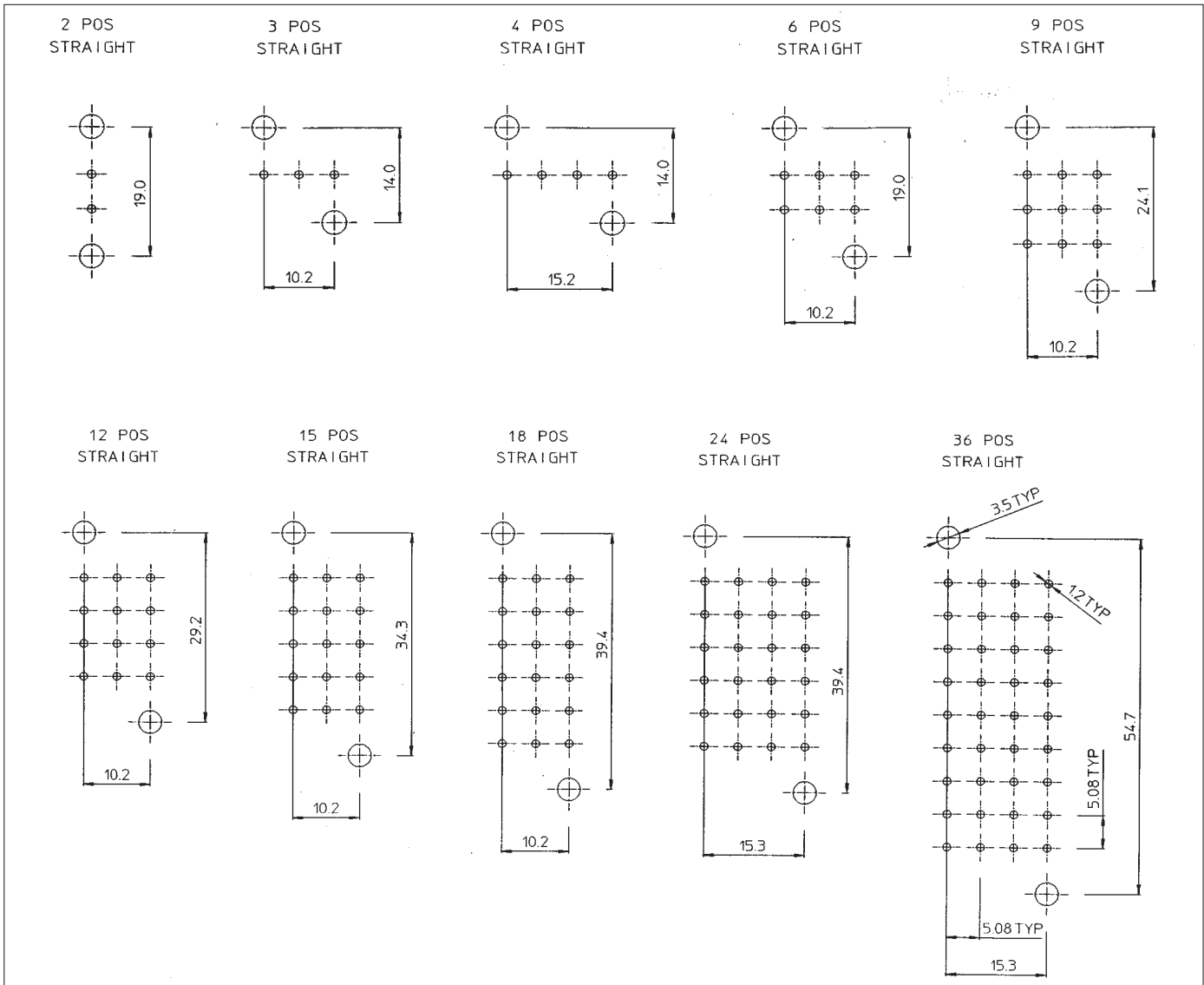

Recommended PC-Board hole lay out for right-angled male and female boardmount connectors

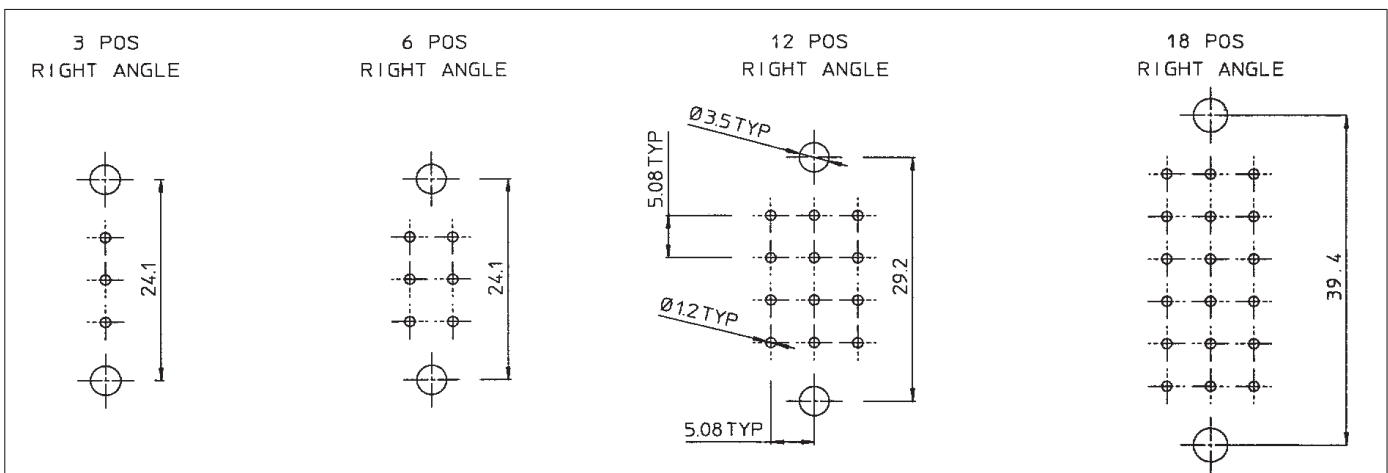



Qikmate PC boardmount Pin Headers and plugs

Description

Qikmate Pin Header, available in 3, 4, 6, 9 and 10 positions, provides the additional versatility of straight and right angle board mounting.

Offered as an alternative to stacked connectors, the in-line contact design of the pin header provides the user with significant PC board space savings.

The boardmount receptacle features positive polarization and a moulded on pin protection skirt and is supplied preassembled with straight or right angled:

- Solid machined or stamped and formed PC board pin contacts.
- Coax PC board pin contacts.

The socket cable plug features positive quick connect / disconnect latches and is designed to accept N° 16 TRIM TRIO .0625" (1.6mm) diameter socket contacts for maximum contact protection.

Features and benefits

- Available in 3, 4, 6, 9 and 10 positions.
- In-line contact design, offering significant PC board space savings.
- Boardmount connectors available in straight and right-angled version preassembled with:
 - Solid machined or stamped and formed pin contacts.
 - Coax pin contacts.

Construction

Connector body:

Glass filled thermoplast UL94-V0

Colour: Black

Contacts: High conductive copper alloy

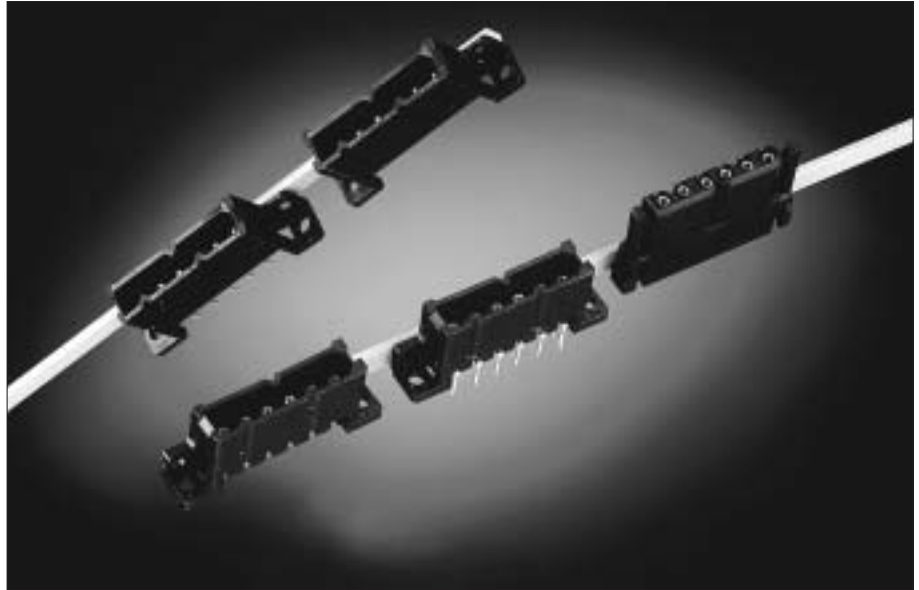

Performance characteristics

Operating temperature:	-55°C to +125°C
Insulation resistance:	5000 MΩ min.
Test potential:	2000 VAC
Current rating:	5 AMP
Durability:	500 matings and unmatings.

Intermateability

- "SMS" Socket plugs accept Trim-Trio crimp-type removable snap-lock contacts (see contact section)
- Contacts to be ordered separately.

Plating table

Plating Table		
Plating Suffix	Description	Plating
TR-29	Tin-Alloy Pre-Plated	
D70	.000005 in (0.13 micron) Gold over .000075 in (1.9 micron) Nickel	Standard
D28	.000030 in (0.75 micron) Gold over .000075 in (1.9 micron) Nickel	Standard
Z17	Min. 0.75µ Au in contact area, Flash on solder tail (inner) Min. 0.75µ Au in contact area, Tin on solder tail (outer)	Selective

How to order

Connector family (Self Mountable System)	SMS	9	PH	3	TR29
	SMS	9	CH	1	Z17
	SMS	9	P3	-	-
Contact arrangement					
Contact type:	PH:	Pin header boardmount.			
	CH:	Coax header boardmount.			
	P3:	Socket cable plug for pin and coax boardmount header.			
Design variation:	1:	Right angle coax header boardmount with male contacts.			
	2:	Straight coax header boardmount with male contacts			
	3:	Right angle pin header boardmount with stamped male contacts			
	4:	Straight pin header boardmount with stamped male contacts			
	GE6:	Right angle pin header boardmount with machined male contacts			
	GE4:	Straight pin header boardmount with machined male contacts			
Plating indication					



Right angle pin header boardmount with male contacts (SMS--PH3 / SMS--PHGE6)

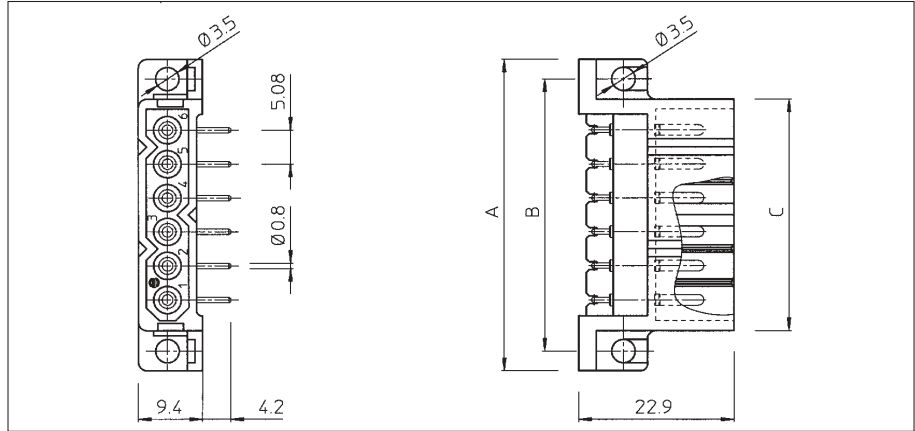

Part number Stamped and formed contacts	Part number Solid machined contacts	Number of contact positions	A	B	C
SMS3PH3TR29	SMS3PHGE6T	3	31.2	25.4	19.3
SMS4PH3TR29	SMS4PHGE6T	4	36.3	30.4	24.4
SMS6PH3TR29	SMS6PHGE6T	6	46.5	40.6	34.5
SMS9PH3TR29	SMS9PHGE6T	9	61.7	55.9	49.8
SMS10PH3TR29	SMS10PHGE6T	10	66.8	61.0	54.9

For other platings: see plating table.

Other solder tail lengths on request

Straight pin header boardmount with male contacts (SMS--PH4 / SMS--PHGE4)

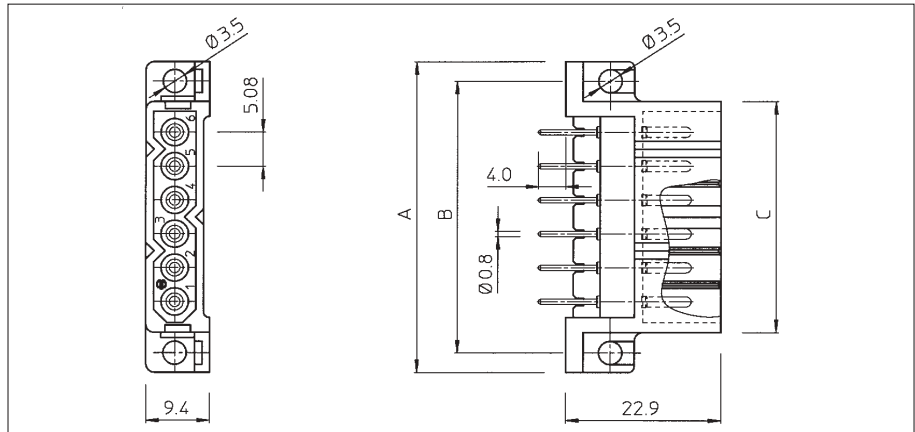

Part number Stamped and formed contacts	Part number Solid machined contacts	Number of contact positions	A	B	C
SMS3PH4TR29	SMS3PHGE4T	3	31.2	25.4	19.3
SMS4PH4TR29	SMS4PHGE4T	4	36.3	30.4	24.4
SMS6PH4TR29	SMS6PHGE4T	6	46.5	40.6	34.5
SMS9PH4TR29	SMS9PHGE4T	9	61.7	55.9	49.8
SMS10PH4TR29	SMS10PHGE4T	10	66.8	61.0	54.9

For other platings: see plating table.

Other solder tail lengths on request



New

Right angle coax header boardmount with male contacts (SMS--CH1Z17)

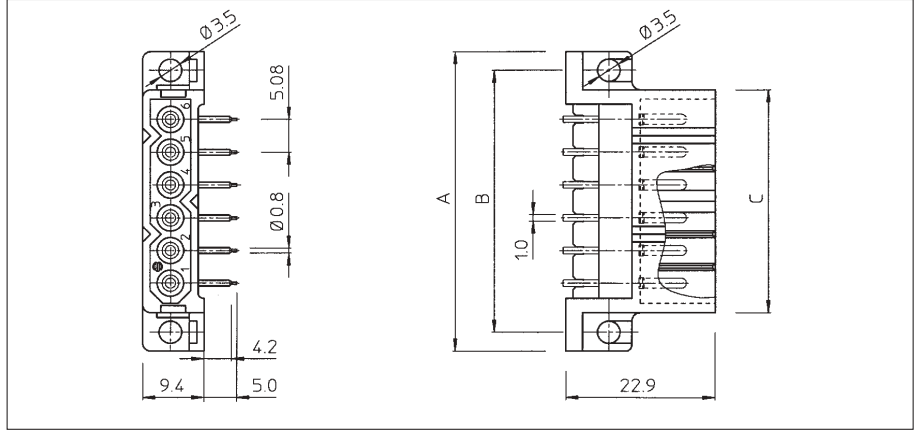

Part number positions	Number of contact	A	B	C
SMS3CH1Z17	3	31.2	25.4	19.3
SMS4CH1Z17	4	36.3	30.4	24.4
SMS6CH1Z17	6	46.5	40.6	34.5
SMS9CH1Z17	9	61.7	55.9	49.8
SMS10CH1Z17	10	66.8	61.0	54.9

For plating spec.: see plating table.

SMS

New

Straight coax header boardmount with male contacts (SMS--CH2Z17)

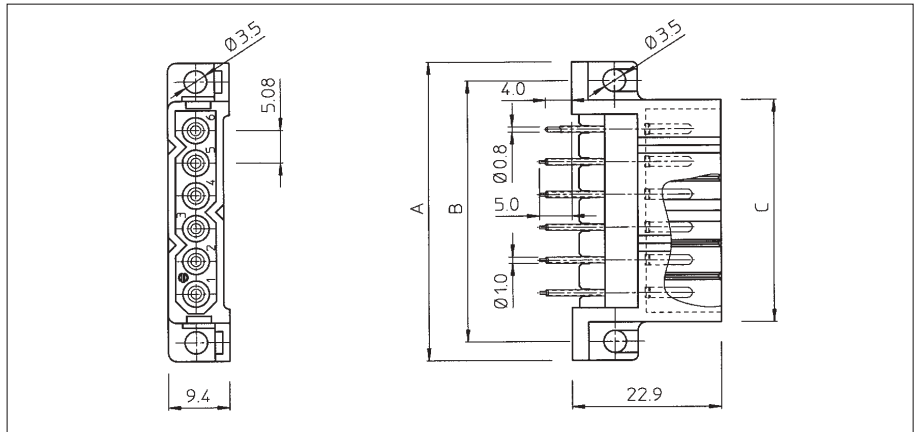

Part number positions	Number of contact	A	B	C
SMS3CH2Z17	3	31.2	25.4	19.3
SMS4CH2Z17	4	36.3	30.4	24.4
SMS6CH2Z17	6	46.5	40.6	34.5
SMS9CH2Z17	9	61.7	55.9	49.8
SMS10CH2Z17	10	66.8	61.0	54.9

For plating spec.: see plating table.



Socket cable plug for pin and coax boardmount header (SMS--P3)

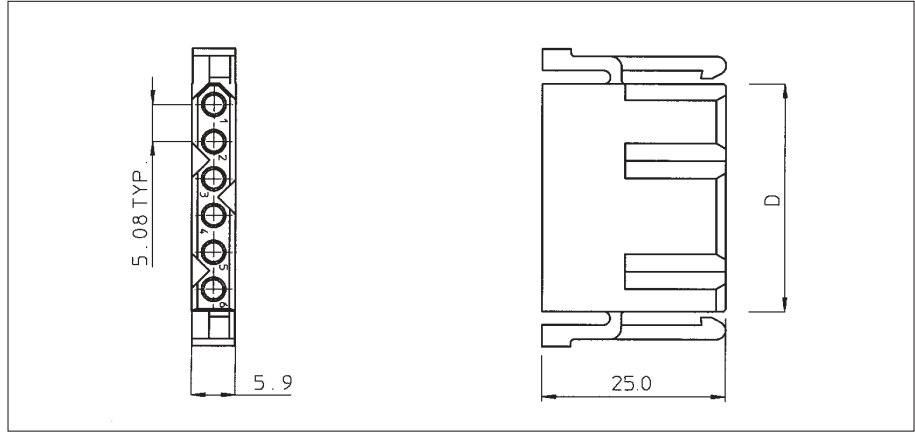

Part number	Number of contact positions	D
SMS3P3	3	16.0
SMS4P3	4	21.1
SMS6P3	6	31.2
SMS9P3	9	46.5
SMS10P3	10	51.6

Recommended PC-board hole layouts

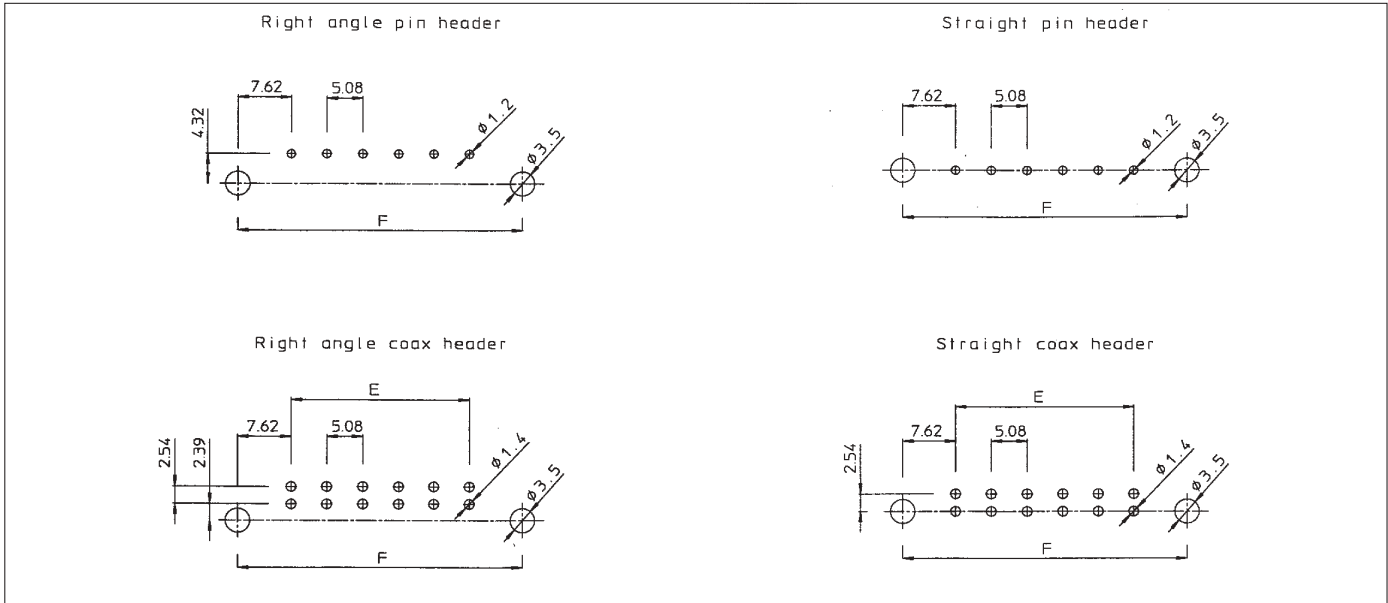

Part number of contact positions	E	F
3	10.18	25.40
4	15.24	30.48
6	25.40	40.64
9	40.64	55.88
10	45.72	60.96



Wire applications

Description

A 43 position two part plug & receptacle connector system, compatible with Trim-Trio contacts and manufactured to DIN41612 style C dimensions.

It is used for power & high frequency signal distribution within a "Eurorack" 19" cardrack system.

Features and benefits

- 19" rack mounted
- Designed to DIN41612 style C dimensions
- Compatible with Trim-Trio contacts
- Contacts are easily replaced
- Any combination of different contact styles can be used within the same housing, including machined, stamped & formed and submix. coax.

Performance characteristics

Operating temperature: -55°C to +125°C

Insulation resistance: 5000 MΩ min.

Construction

Material: 30% glass filled polyester

Flammability rating: UL94V-O

Colour: light grey

Contact accomodation

P143 connectors accept

- RM/RC Machined contacts
- SM/SC Formed two-piece contacts
- RMDX/RCDX coaxial contacts
- Fibre optic contacts

Contacts to be ordered separately, see contact section.

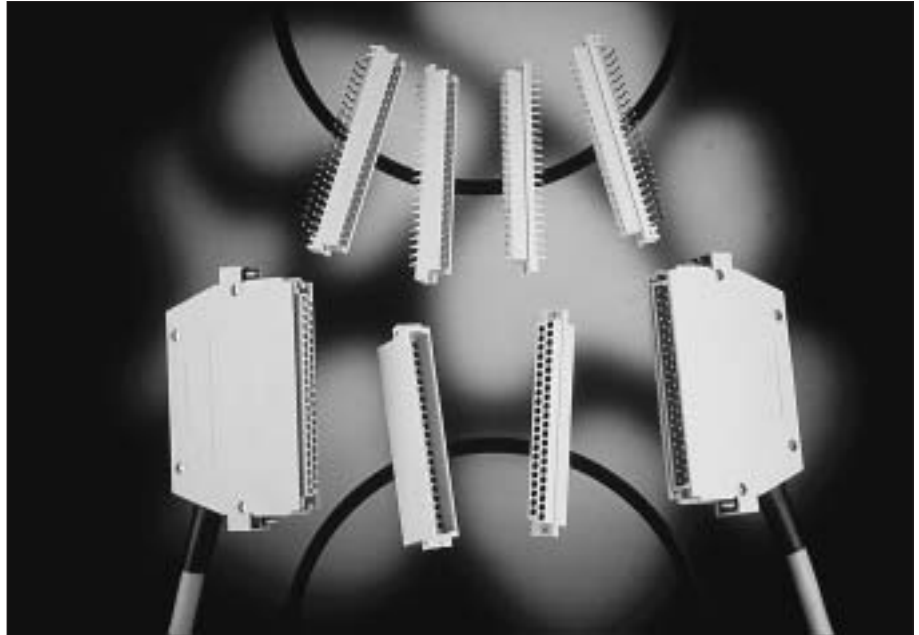

Wire to wire derating curve

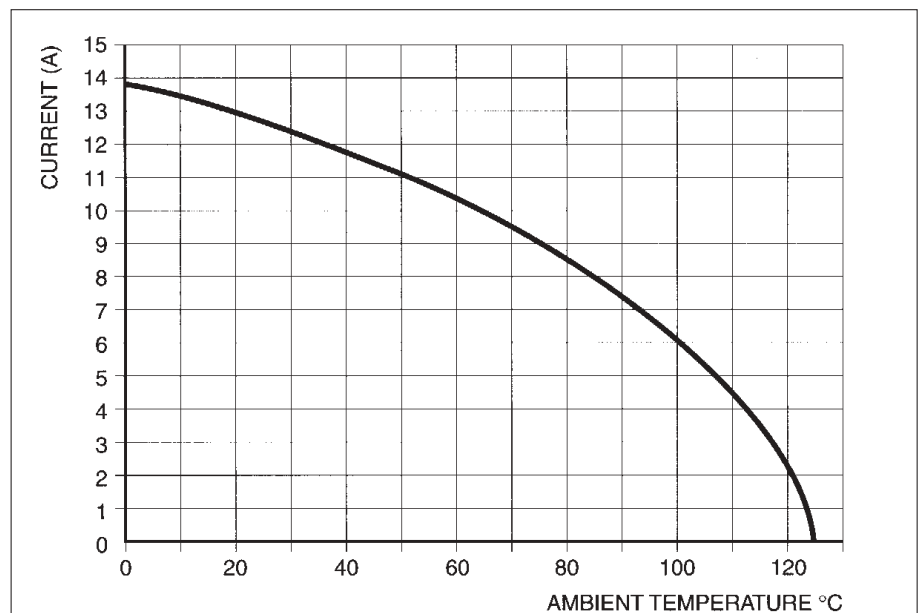

Test with 43 mach. contacts / Ø 1,6 mm / 1,5 mm²



Plug wire housing with 90° mounting

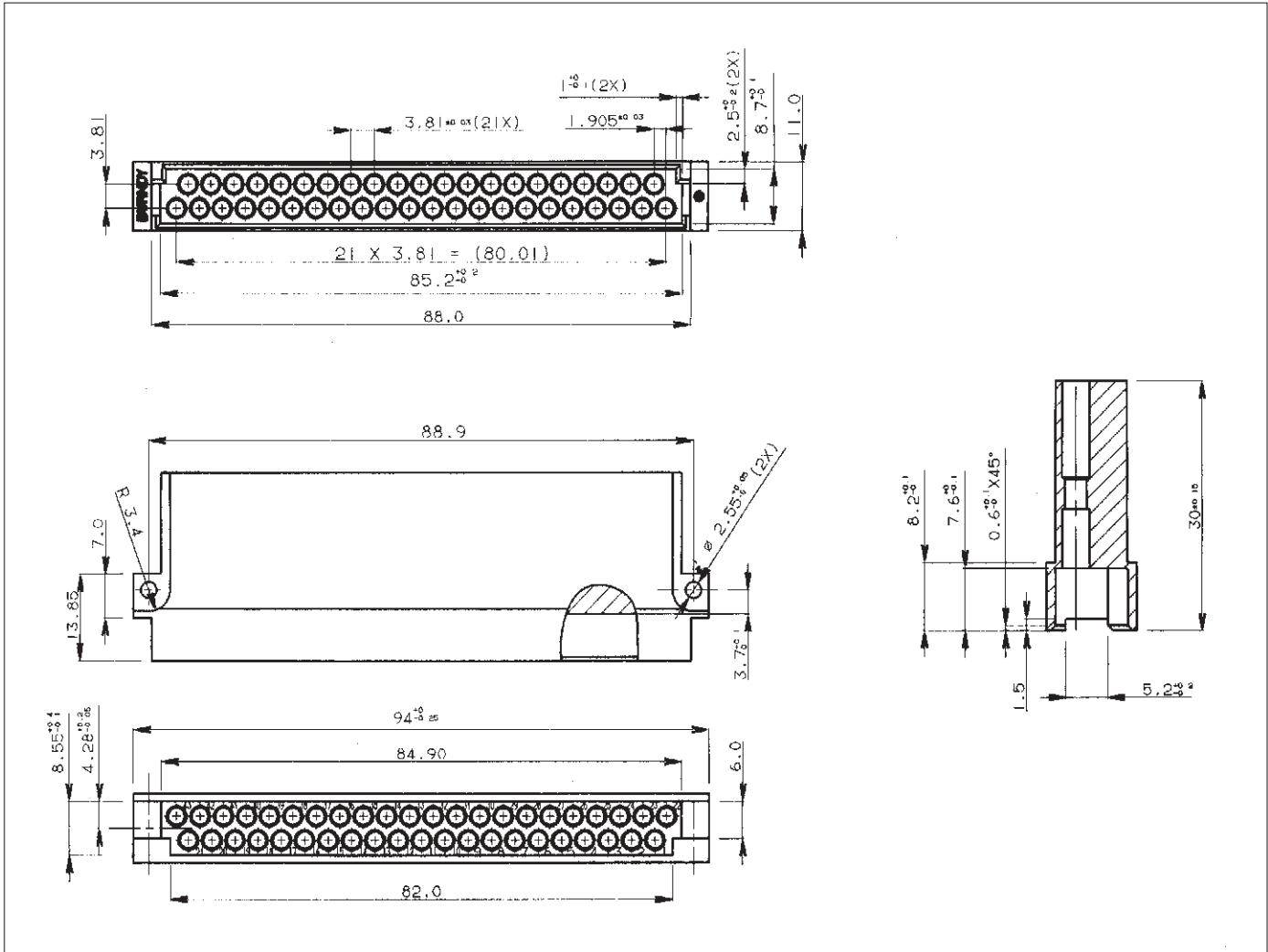

How to order: PI43G2PTA10P1

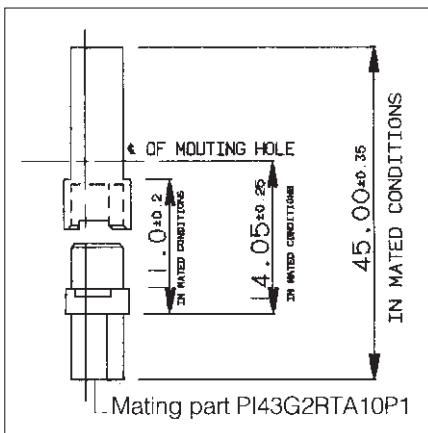



Receptacle wire housing with straight mounting

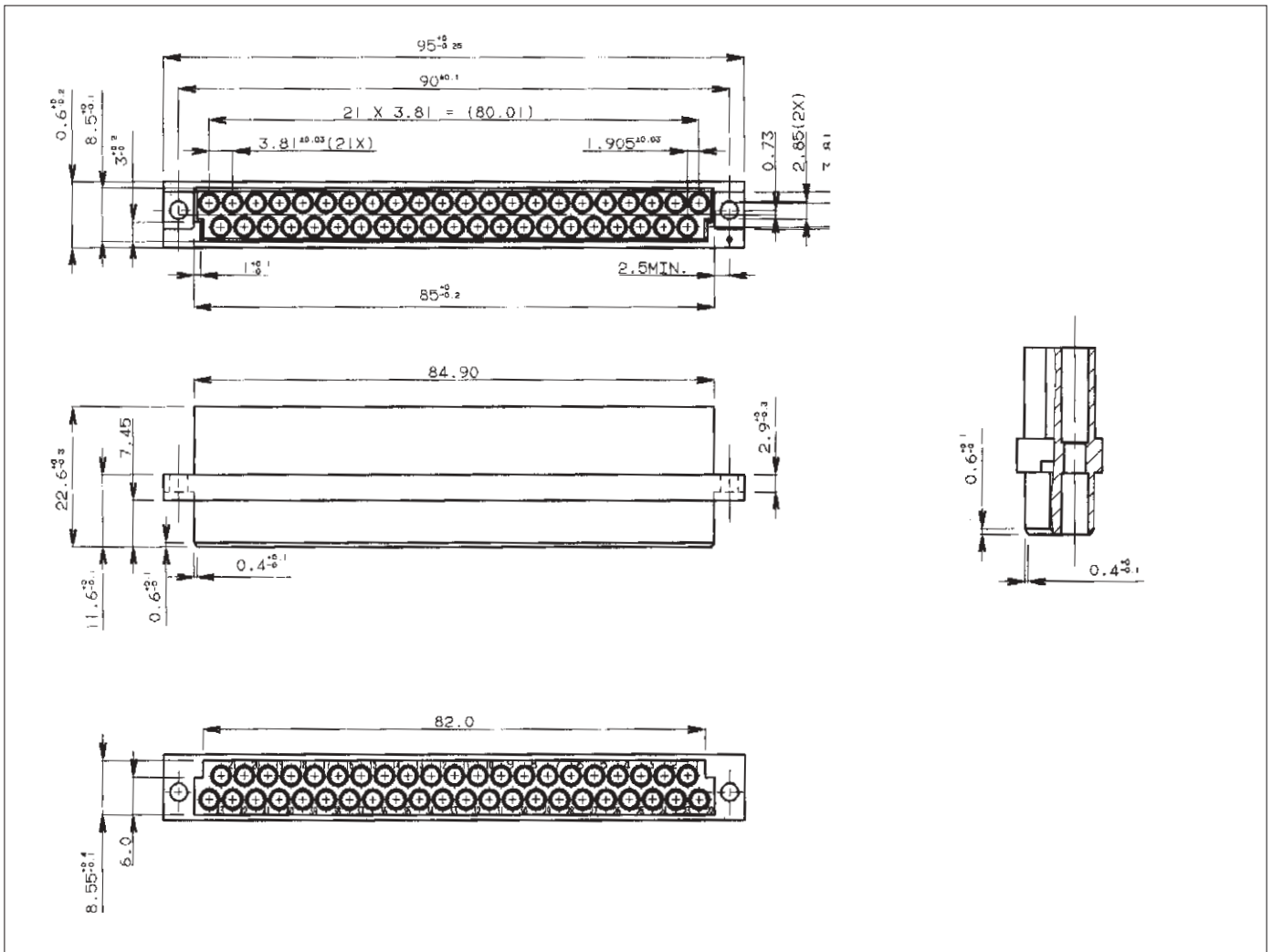

How to order: PI43G2RTA10P1

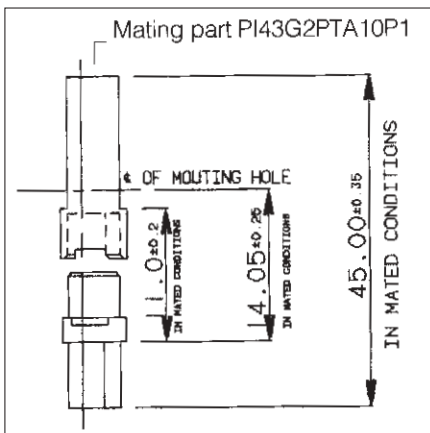



Boardmount applications

Description

The PI43 boardmount version, derived from the wire version, is for direct application on a printed circuit board and manufactured to DIN41612 style C dimensions. The preassembled PI43 connectors with pin or socket N° 16 contacts are intermateable with the existing wire versions. It is used for power & high frequency signal distribution within a "Eurorack" 19" cardrack system.

Features and benefits

- Connector supplied preassembled with 43 dipsolder contacts.
- Available with pin and socket contacts for both straight and right-angle terminations.
- 19" rack mounted
- Designed to DIN41612 style C dimensions.
- Selective loading and other termination lengths optional.

Performance characteristics

Operating temperature: -55°C to +125°C

Current rating: 7,5 Amp

Contact resistance: $\leq 3\text{m}\Omega$

Operating voltage: 750 V RMS

Test potential: 2000 VAC

Insulation resistance: 5000 M Ω

Durability: 500 cycles



Construction

- Connector Body: 30% glass filled polyester
flammability rating: UL94VO
colour: light grey
- Contacts: high conductivity copper alloy
- Plating: no digit (Std) = 0.4 μ min gold over nickel
 - J = gold flash over nickel
 - N = 0.75 μ min gold over nickel
 - T = 3-5 μ Tin

Intermateability

The PI43 boardmount connectors with preassembled contacts are intermateable only with the PI43 wire versions equipped with:

- RC/CM machined contacts
- SC/SM formed two piece contacts

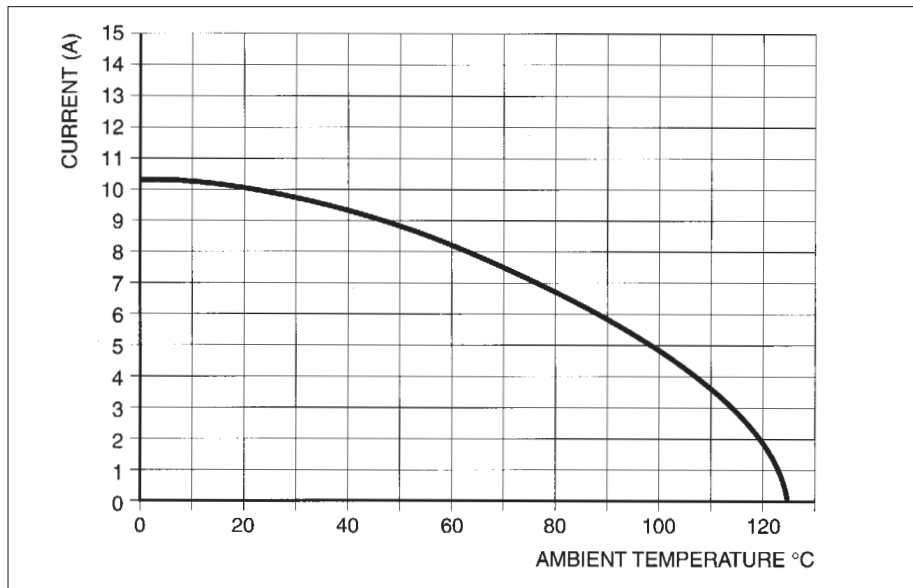

Test with 43 mach. contacts / \varnothing 1,6 mm / 1,5 mm²



Straight boardmount plug

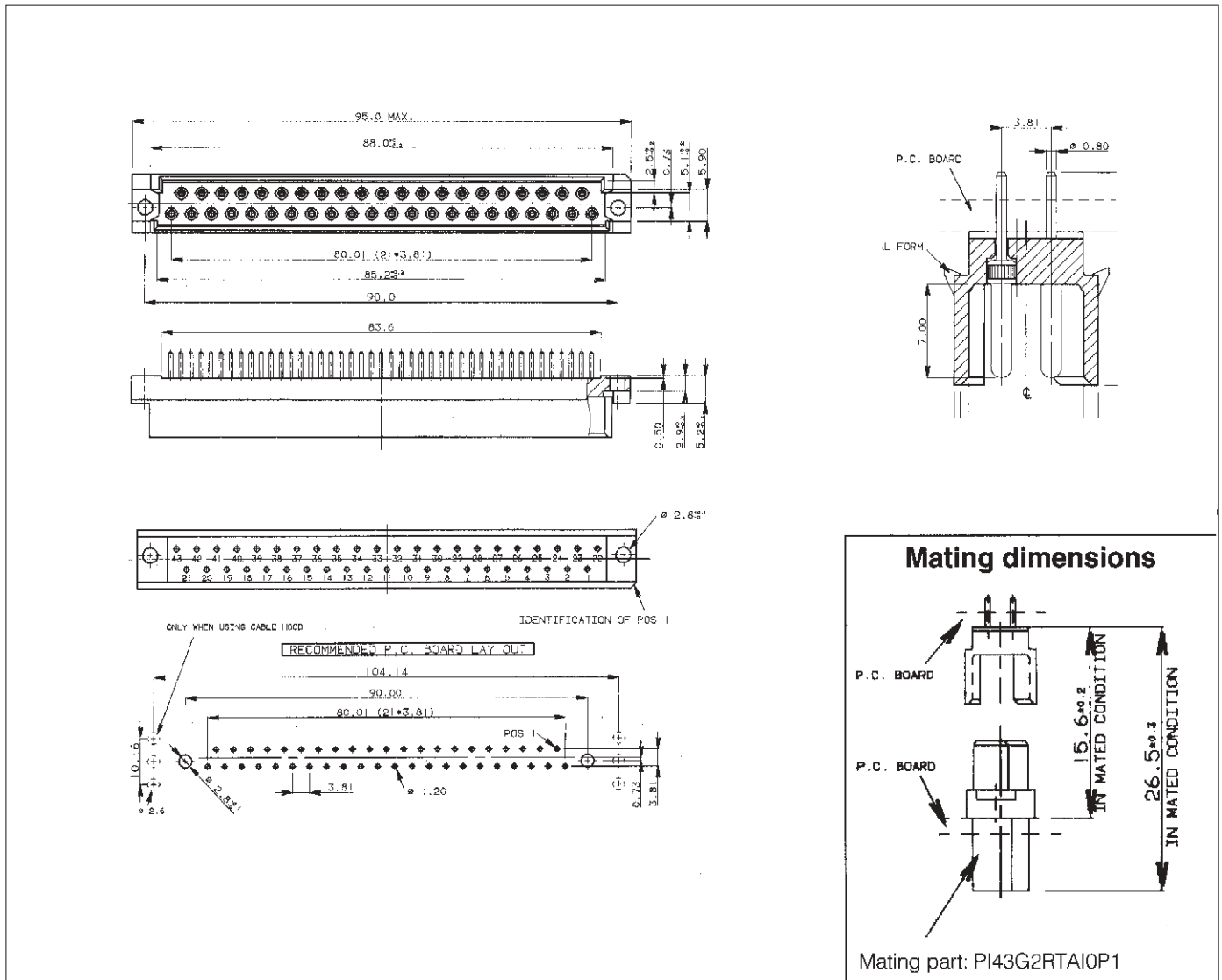

How to order: RPI43G20P5C00 - (standard)

Connector Family	RPI43G	20	P5	C	0	0	-
Contact arrangement:	two rows fully loaded						
Variations:	plug housing with preassembled straight female dipsolder contacts						
Termination:	4,50 mm						
Material:	30% glass filled polyester - colour: grey						
Machined contacts							
Plating:							

Right-angle boardmount plug

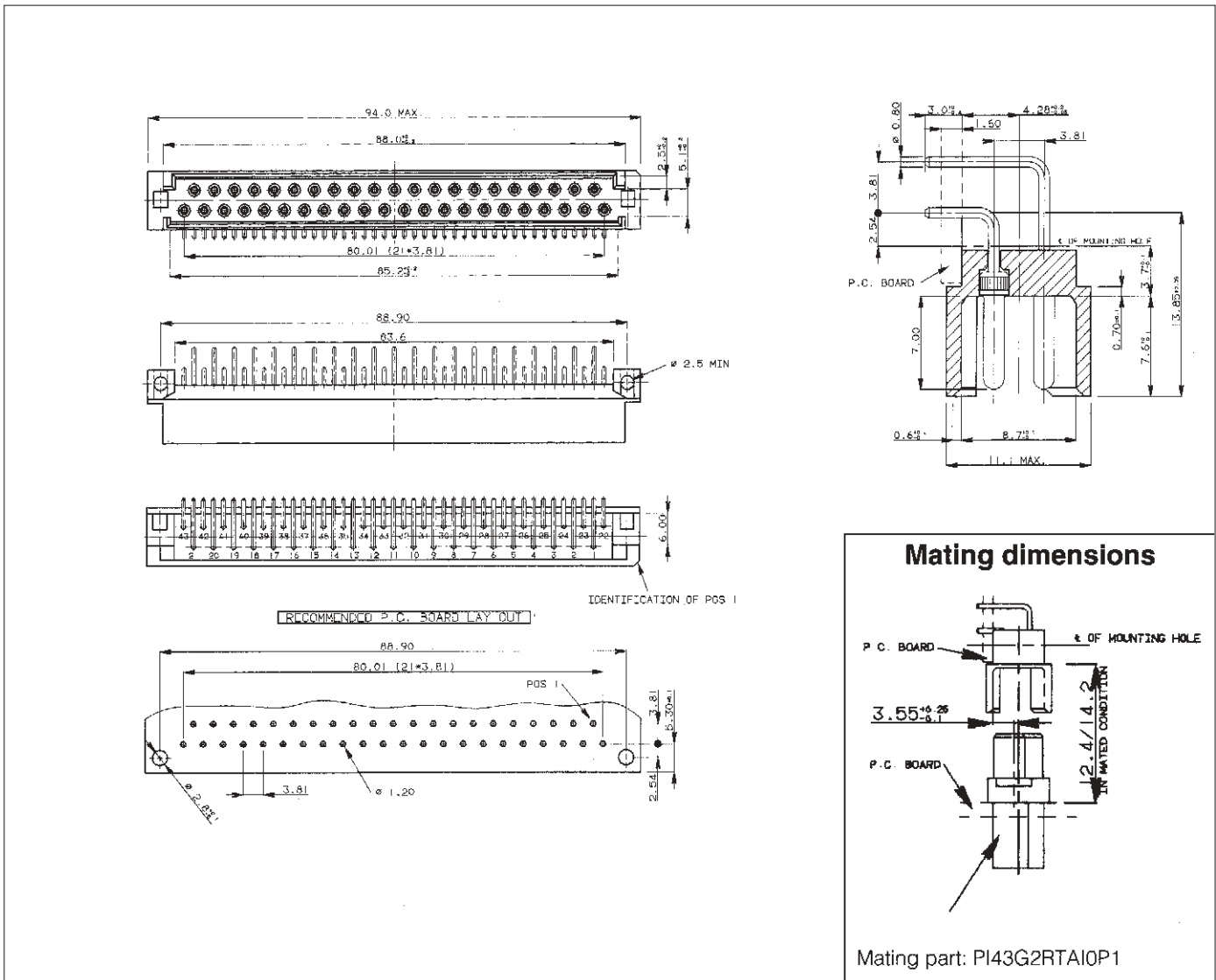

How to order: RPI43G20PTBF08 - (standard)

Connector Family	PI43G	20	PTB	F	0	8	-
Contact arrangement:	two rows fully loaded						
Variations:	plug housing with preassembled right-angle male dipsolder contacts						
Termination:	2,75 mm						
Material:	30% glass filled polyester - colour: grey						
Machined contacts							
Plating:							



Straight boardmount receptacle

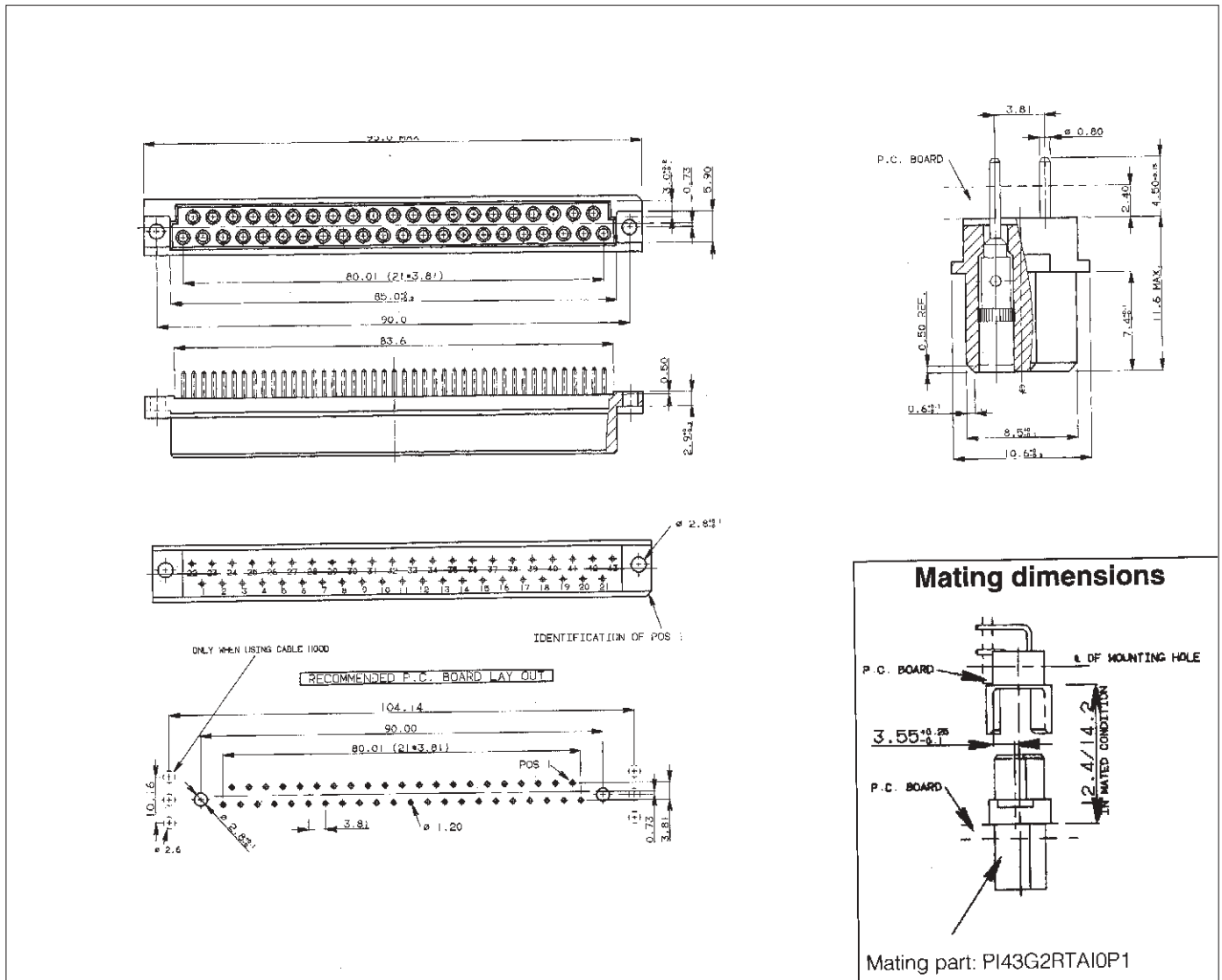

How to order: PI43G20RTBC0E - (standard)

Connector Family	PI43G	20	RTB	C	0	E	-
Contact arrangement:	two rows fully loaded						
Variations:	plug housing with preassembled straight female dipsolder contacts						
Termination:	4,50 mm						
Material:	30% glass filled polyester - colour: grey						
Machined contacts							
Plating:							



Right-angle boardmount receptacle

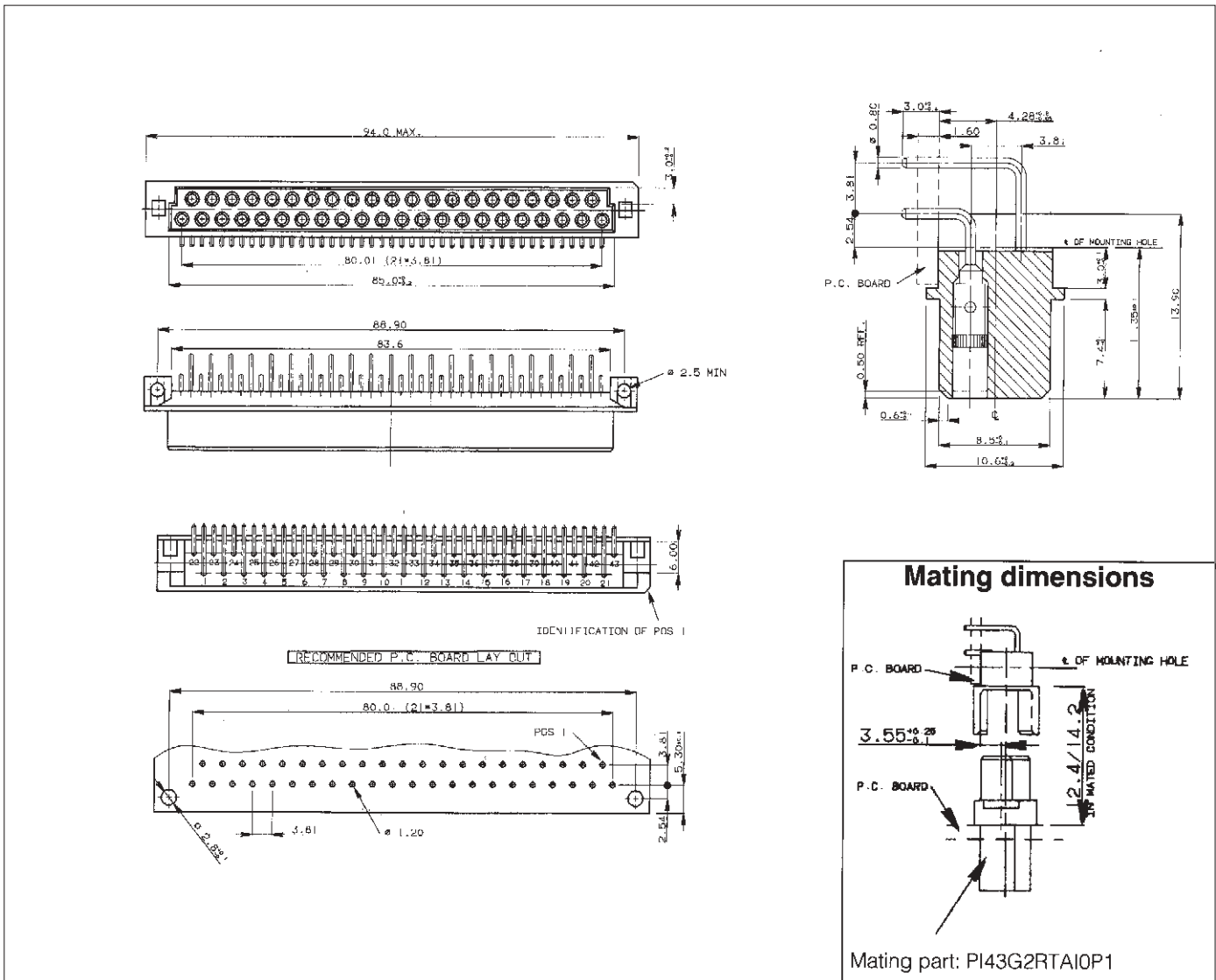

How to order: RPI43G20R5G00 - (standard)

Connector Family	RPI43G	20	R5	G	0	0	-
Contact arrangement:	two rows fully loaded						
Variations:	plug housing with preassembled right-angle male dipsolder contacts						
Termination:	2,75 mm						
Material:	30% glass filled polyester - colour: grey						
Machined contacts							
Plating:							

Accessories

Cable hood + Locking keys

The cable hood + locking keys offers the opportunity to have a reliable cable strain relief and an easy locking system between the two mating parts.

The hood meets the demand for a fully-insulated compact housing suitable for holding either the male or female half of connectors manufactured to DIN41612 style C dimensions.

The locking keys can be chosen in function of the application and assist in guiding and matching the two connector halves and also offering coding possibilities.

Features and benefits

- a strong fully-insulated housing
- Exclusion of any mechanical stress on multi-pin connectors during insertion, operation and withdrawal forces
- 19" rack mounted
- Designed to DIN41612 style C dimensions
- Three alternative cable outlet positions
- Reliable strain relief
- Quick mating
- Locking keys assist in guiding and coding

Construction

- Moulded parts:
 - polycarbonate 30% glass filled
 - colour: hood - lightgrey
 - Locking keys- black
- Flammability rating: UL94V1
- Temperature range: -65°C to +125°C
- Hardware: surface treated steel

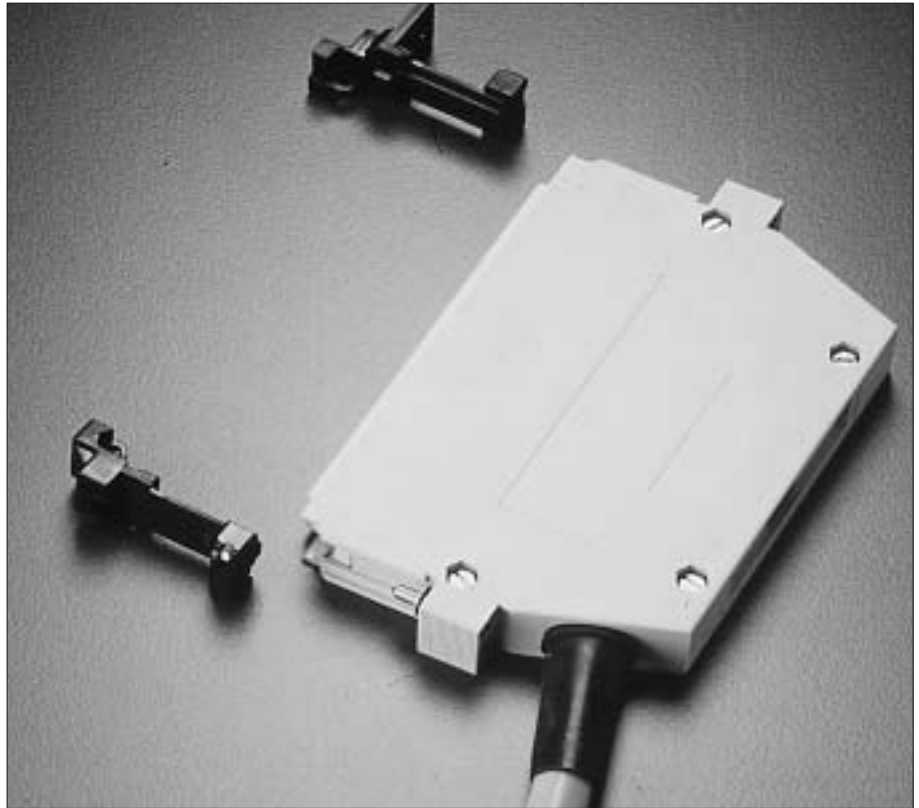

Cable Hood

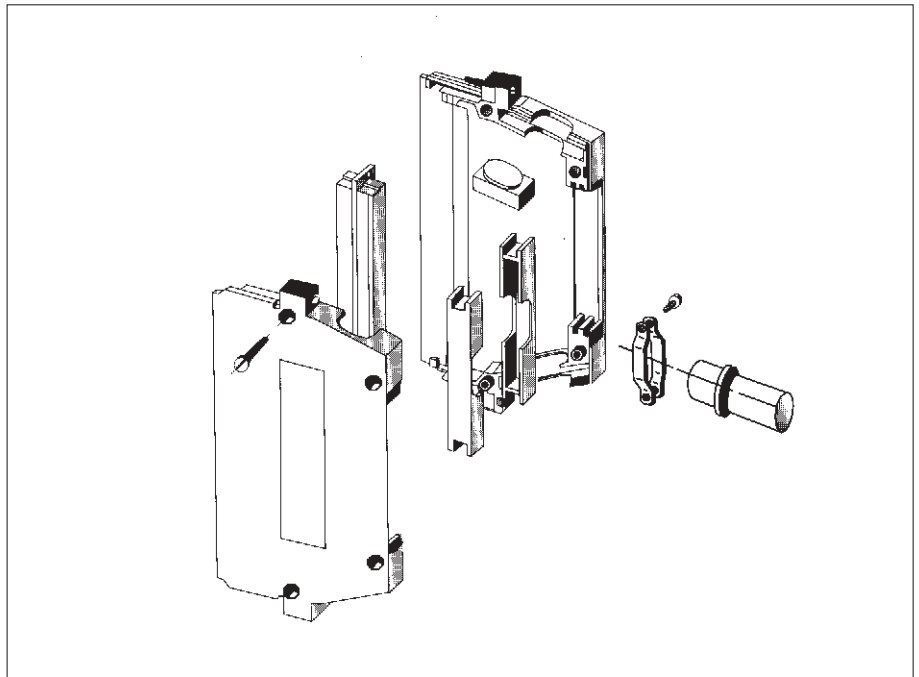

Accessories

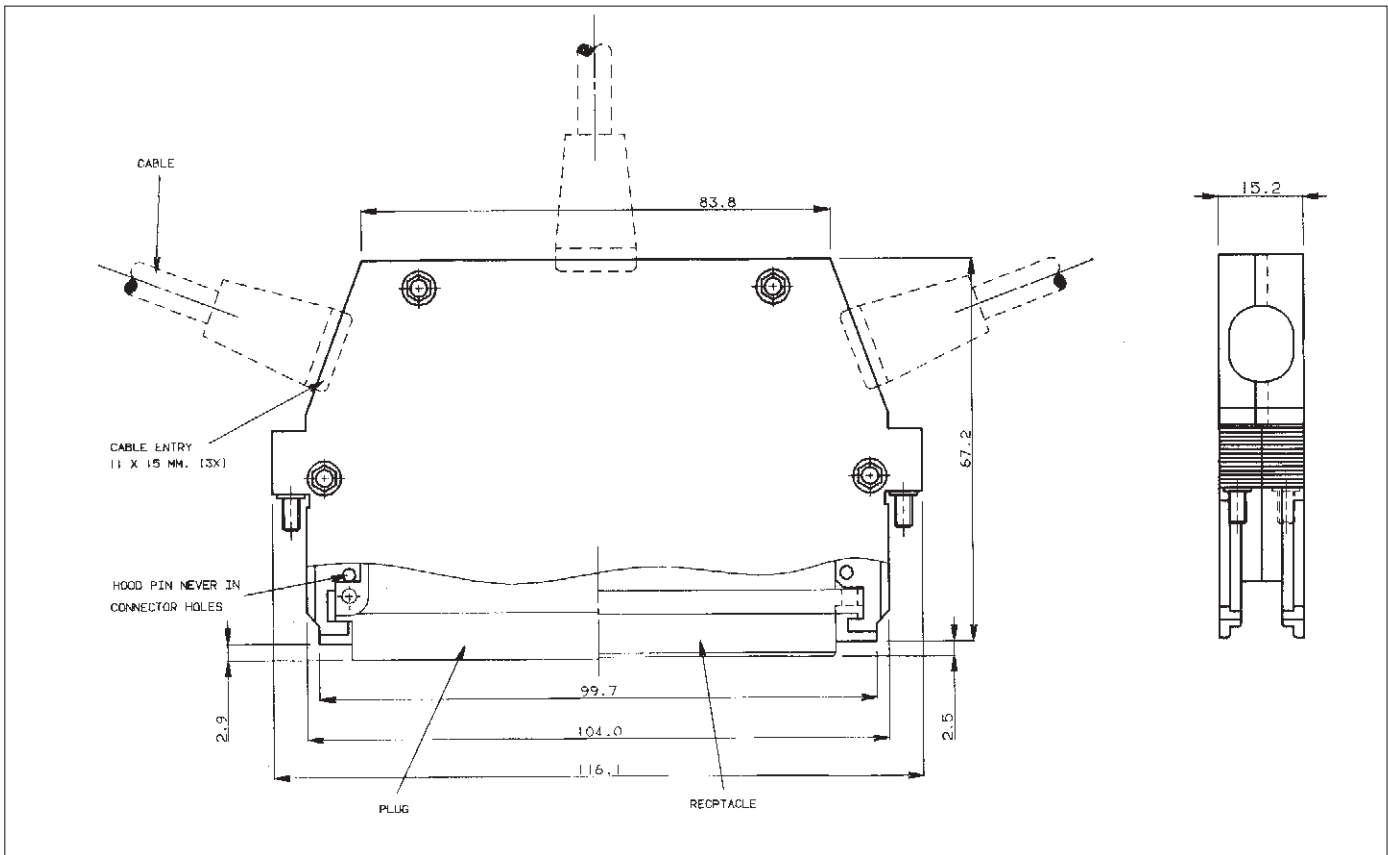

How to order: PI96CAP1

For intermateability chart:

see next pages

Locking keys

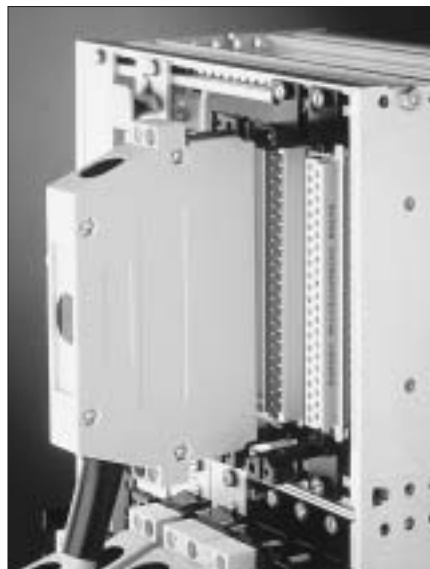
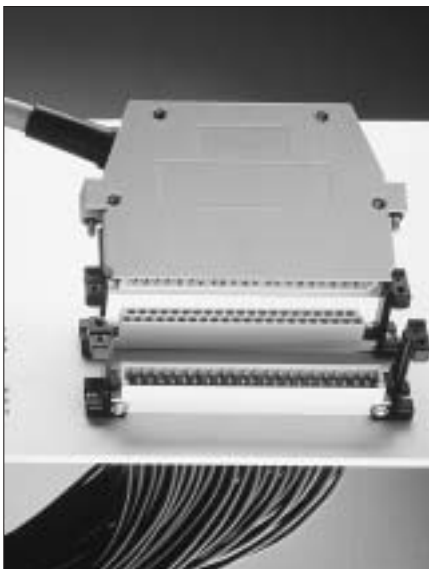



Intermateability chart

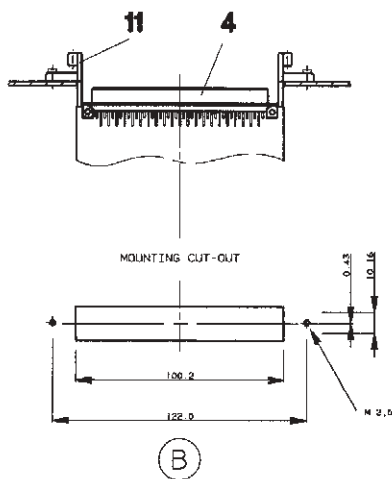
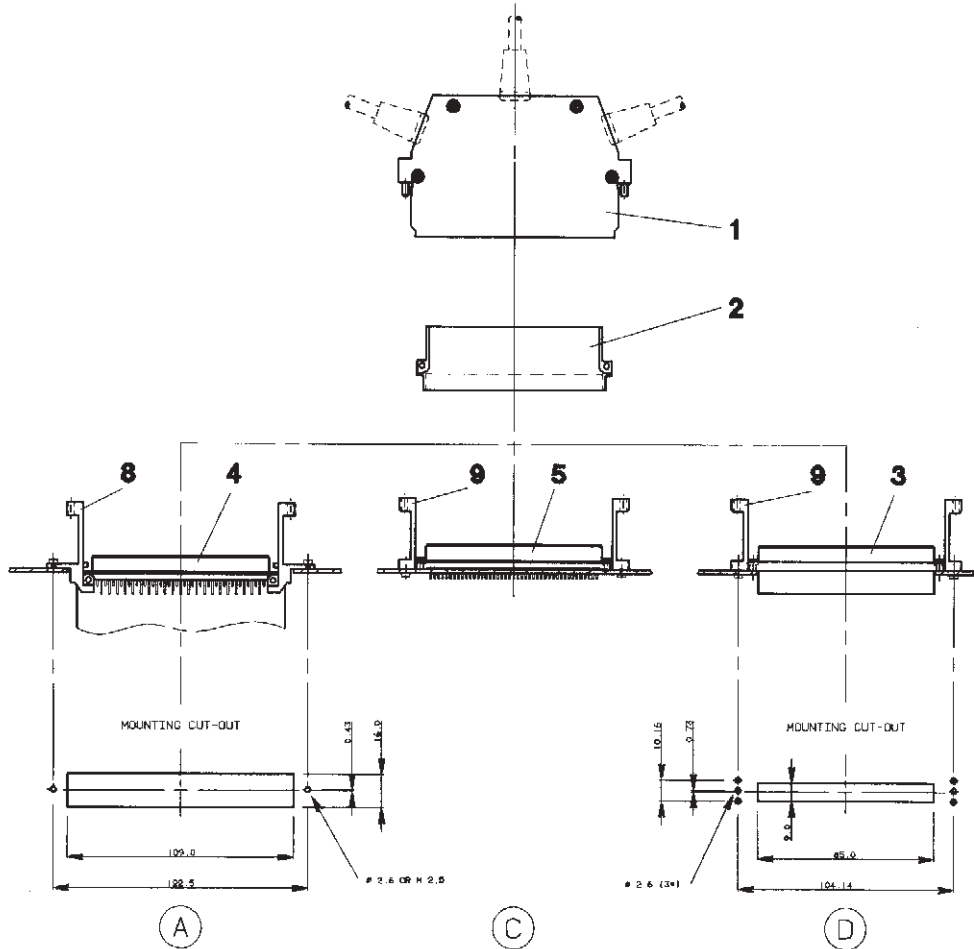

No.	Type of connection	Application all 19" rack mounted
A	Wire plug to right-angle boardmount rec.	Front panel
B	Wire plug to right-angle boardmount rec.	Back panel
C	Wire plug to straight boardmount rec.	Front and back panel
D	Wire plug to wire receptacle	Front and back panel
E	Wire rec. to right-angle boardmount plug	Front panel
F	Wire rec. to right-angle boardmount plug	Back panel
G	Wire rec. to straight boardmount plug	Front and back panel
H	Wire receptacle to wire plug	Front and back panel



Intermateability chart

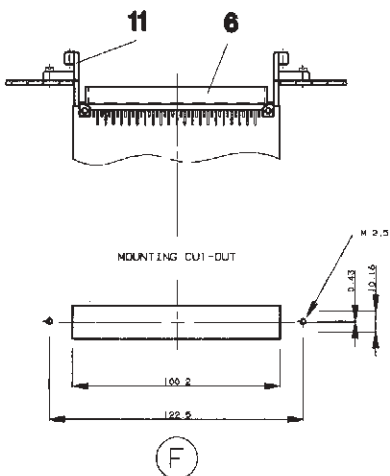
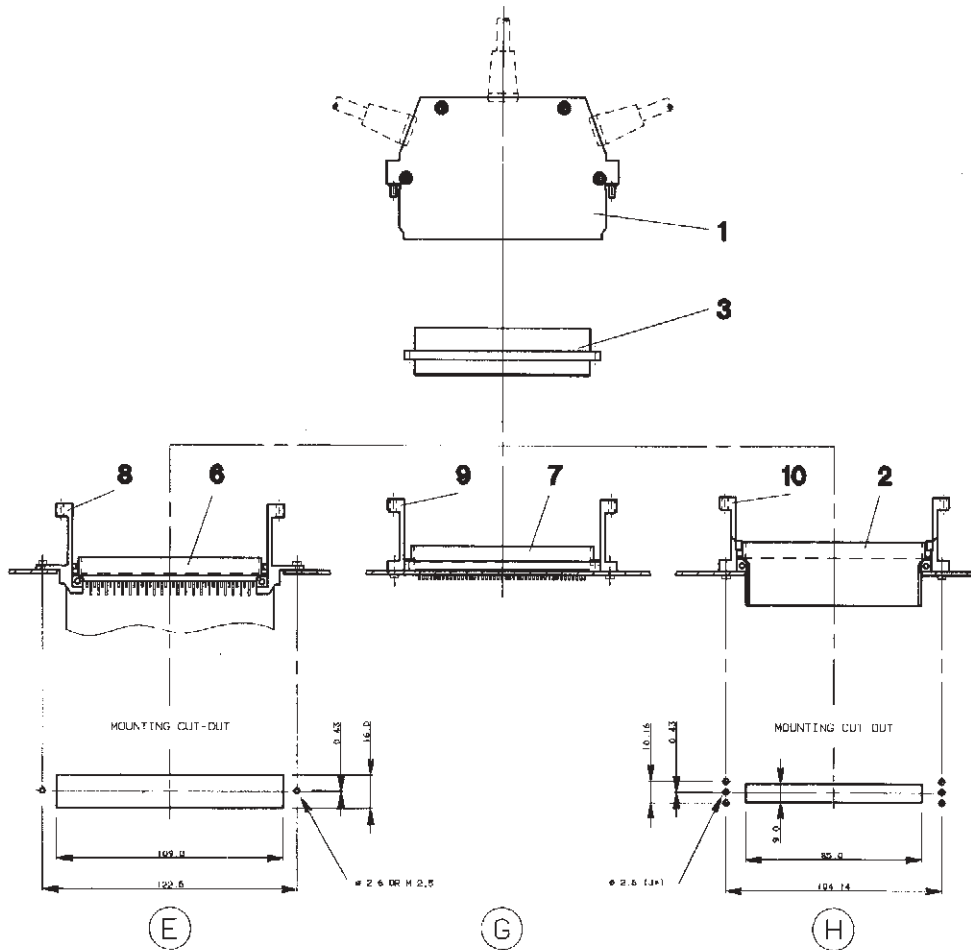

Pos.	Description	How to order standard version
1	Cable hood	PI96CAP1
2	Wire plus	PI43G2PTA10P1
3	Wire receptacle	PI43G2RTA10P1
4	Right-angle boardmount receptacle	RPI43G20R5G00
5	Straight boardmount receptacle	PI43G20RTBC0E
6	Right-angle boardmount plug	PI43G20PTBF08
7	Straight boardmount plug	RPI43G20P5C00
8	Right-angle locking-key set 1	PI96LOK90SET1
9	Straight locking-key set	PI96LOK180SET2
10	Right-angle locking-key set 2	PI96LOK90SET2
11	Right-angle locking-key set 3	PI96LOK90SET3



Overview TRIM TRIO and SEALOK contacts

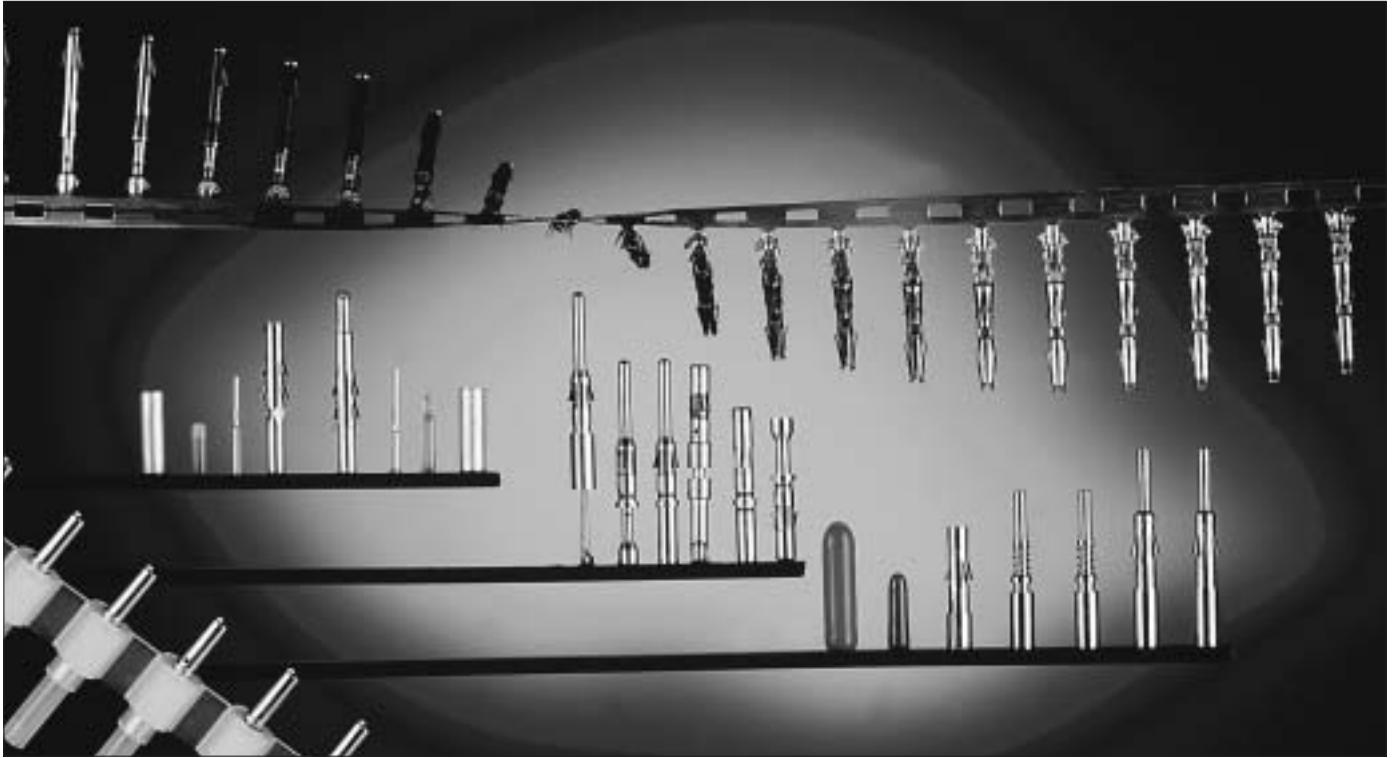

Selection matrix TRIM TRIO and SEALOK contacts

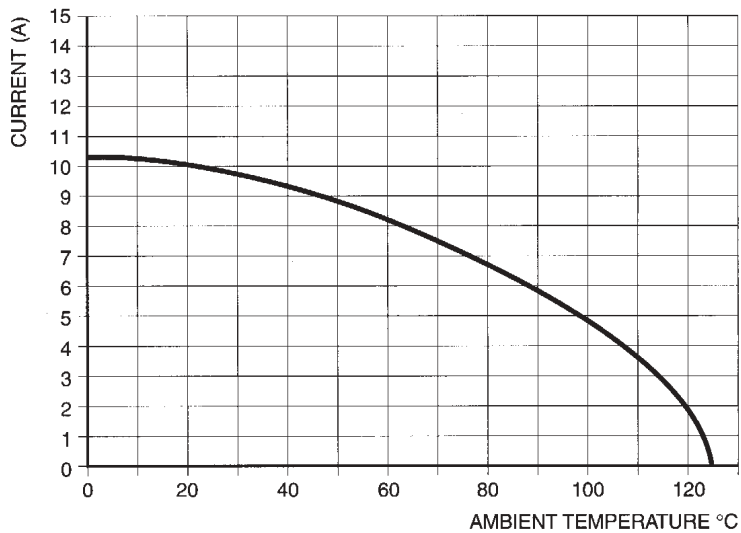



Current ratings for multi-contact connectors

Choice of right connector - contact combination.

The choice of a Trim Trio connector in combination with a Trim Trio contact is essential and different for any application. There is considerable misunderstanding in the field on current carrying capabilities for the various contacts in the Trim Trio programme.

The intention of this part is to give guidance how to interpret the given current ratings in general and how to calculate them for particular applications.

The information given is based upon existing MIL specifications such as: MIL-C-26482, MIL-C-8384, MIL-T-7928, MIL-W-5086, MIL-W-5088, MIL-W-16878, etc. and in conjunction with long field practice.

Current carrying capabilities

Trim Trio contacts are designed to carry a specific current, in accordance with the applicable specification.

This specification will be defined by following variables:

- **Connector size**

The more contacts in a connector, the less current per contact can be loaded.

- **Wire size** (see table 1)

The cross section will determine the internal resistance and temperature rise for a given current.

-Table 1 gives the current ratings for the various wire sizes commonly used with Trim Trio contacts.

- **Current rating** (see table 2)

The current load for a given application will generate heat.

- Table 2 gives the *maximum current carrying capacity* of most of the Trim Trio contacts, the *maximum operating current* and the *recommended continuous current*.

- **Ambient temperature**

The combination of the connector size, the wire size and the current rating will generate a temperature rise.

This temperature rise + a given ambient temperature may not exceed the maximum operating temperature of the connector material (see performance characteristics for each connector family).

Table 1 - Current carrying capabilities per wire size

AWG	wire size mm ²	wire dia. mm Amp.	max.curr. carrying Amp.	max.operating curr. Amp.	recomm. cont. curr.
26	0.13	0.40	3	2	1
24	0.20	0.51	4.5	3	2
22	0.32	0.64	9	5	3
20	0.52	0.81	11	7.5	5
18	0.82	1.02	16	10	7.5
16	1.30	1.29	22	13	10
14	2.10	1.63	32	17	13

Table 2 - Current carrying capabilities per contact type

size	pin dia.	type	max. curr. carrying Amp.	max. operating curr. Amp.	recomm. cont. curr. Amp.
16	.062* 1.6 mm	RM / RC machined	22	13	10
		SM / SC 2 piece stamped	22	13	10
20	.040* 1.0 mm	SM-W / SC-W 2 piece stamped	11	7.5	5

- *Max. current carrying capacity*
- *Max. operating current*
- *Recommended continuous current*

What do these values mean in practice ?

- *Max current carrying capacity* of a contact is defined by the conducting section of the contact in its smallest area. The listed values are obtained from several tests in laboratories under room conditions (21°C). The contact is considered to be in free air.

- *Max operating current* is the current with which the contacts can be energized during a longer or shorter period, without deteriorating and depending on working conditions. These are dissipated heat, cooling provisions, ambient temperature, insulation material, etc.

- *Recommended continuous current* can be applied for all normal cases and working conditions. The values include a safety margin. However, there are restrictions in the application of the given values. The most important restriction is the used wire, its sectional area, insulation temperature range, as well as wires in bundles. Military specifications require that for a cable bundle of 15 conductors or more, the bundle shall not carry more than 20% of the total carrying capacity of the bundle. In smaller bundles, the allowable percentage of total current may be increased as the bundle approaches the single wire condition. This percentage of increase in total current carrying capacity of the bundle is 6% for each conductor less than 15 in a bundle.



From simple calculations, one can see that the closer the bundle approaches the single wire condition, the higher the allowable current per conductor becomes, to even such an extent, that it exceeds the recommended continuous current value. In that case, the recommended continuous value should have preference. In order to make this clear, we will give hereafter some typical examples.

• **Example 1**

Cable bundle, 48 conductors AWG20 (0.5mm²) used with circular TrimTrio connector with insert arrangement 24-48 and machined size 16 contacts RM/RC20.

- Total operating current capacity of bundle 48 x 7.5 A (table I) = 360 A
- Total allowable capacity for bundles of more than 15 wires is 20% = 72 A
- When all conductors are energized equally, this gives:
72 : 48 = 1.5 A per conductor

When for instance 5 conductors are energized to the recommended continuous current of 5 A (see table 1) resulting in 25 A consumption, the other conductors may not take more than
72 - 25 = 47 A all together, or 1 A per conductor.

Any other combination can of course also be taken as long as the total capacity of 72 A is not exceeded and the recommended continuous current is respected.

Remark

Please note that contacts used are of the size 16 type with maximum operating current of 13 A (table 2).

The maximum operating current of the bundle is however restricted to 7.5 A per conductor due to the wire size of AWG20 (see table 1).

• **Example 2**

Cable bundle, 14 conductors AWG22 (0.32 mm²) used with rectangular Trim Trio connector with insert arrangement for 14 contacts, and machined size 16 contacts RM / RC20.

- Total operating current capacity of bundle 14 x 5 (table I) = 70 A
- Total allowable for wire bundle of 15 wires less 1 is 20% + 6% = 26% gives 18.2 A.
- All conductors energized equally, gives:
18.2 : 14 = 1.3 A per conductor

This value is within the recommended rating of 3 A so that it can be applied. See also remark under example 1.

• **Example 3**

Cable bundle, 4 conductors AWG16 (1.3mm²) used with circular Trim Trio connector with insert arrangement 10-4 and stamped 2 piece contacts SM /SC.

- Total operating current capacity of bundle 4 x 13 A (table I) = 52 A
- Total allowable for wire bundle of 15 wires less 11 is 20% + 66% = 86% gives 44.7 A.
- All conductors energized equally, gives:
44.7 : 4 = 11.2 A per conductor

Since the recommended continuous current is 10 A, the conductor should not carry more than 10 A individually.

As said before, the recommended ratings are valid for most common wiring systems and under normal working conditions. For extreme conditions, the given values should be lowered. The percentage of current reduction should be investigated from case to case. A rule-of thumb which can be used for such cases is:

4 Amp. per mm² wire section

It gives us for common used wire sizes the values listed in table 3.

Table 3 - Recommended continuous current for extreme working conditions

AWG	wire size mm2	recommended continuous current Amp.
26	0.13	0.5
24	0.20	0.8
22	0.32	1.3
20	0.52	2.0
18	0.82	3.3
16	1.30	5.2
14	2.10	8.4



Crimping instructions

The conductor and insulation crimp section

Are designed to accommodate wire-conductor and insulation diameters, expressed in AWG (American Wire Gauge) or mm².

For each wire gauge, a correct crimp requires a crimp height that offers the highest performance.

This performance is defined as the highest tensile strength force.

A good conductor crimp can be guaranteed if the tensile strength force is equal or higher as indicated on the graph below. E.g. a conductor of AWG20 (0.52 mm²) has a good crimp if the tensile strength is min 84N.

The tensile strength force is measured in Newtons and is the wire-to-contact connection that will withstand when a straight axial load is applied to the terminated wire. This is however a destructive test and is therefore inappropriate as a 100% inspection method.

An alternative method is to measure crimp height. The crimp height is measured at the conductor-crimp section.

- **If the dimension is to small**, then the conductor is over-crimped and the wire strands could be damaged, which results in a lower tensile strength force.

- **If the dimension is to large**, then the conductor is under-crimped and the wire strands will not be deformed enough to assure that the crimp will pass the tensile strength test.

In both cases, the application tooling's crimp height should be adjusted.

In order to have the right tooling's crimp height go and no-go gauges can be obtained and are defined in function of the type of crimp tooling and the wire gauge. For further information consult factory.

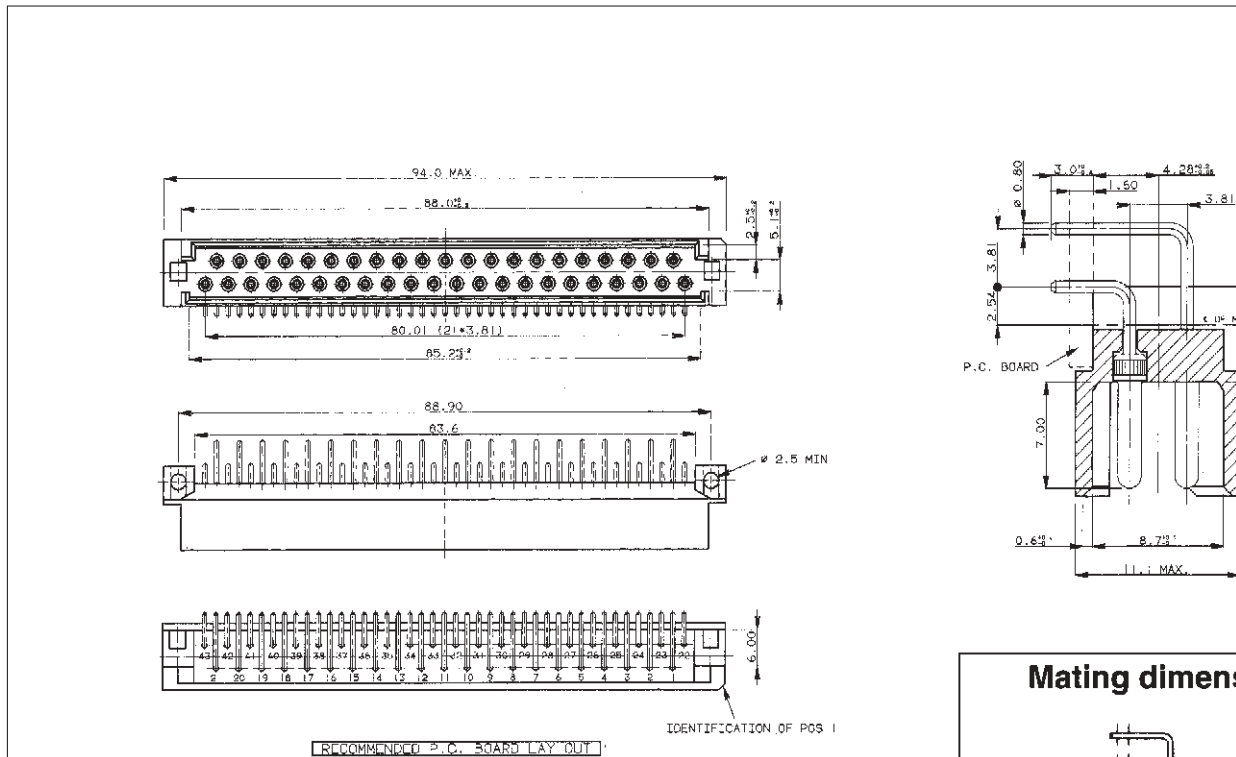



Size 16 solid machined contacts for TRIM TRIO connectors

Description

Size 16 RM/RC .0625" (1.6mm) diameter contacts are precision solid machined crimp snap-in pin and sockets for heavy duty top performance requirements.

Springs on both contacts are made of spring-tempered, heat-treated, beryllium copper.

The socket inner spring supplies high contact pressure to ensure low-resistance contact between pin and socket. The socket contact features closed entry to prevent probe damage. Crimp barrels have insulation grips for vibration support and are provided with a cable stop and inspection hole.

Features and benefits

- Made from high conductive copper alloy with gold or tin over nickel plate finish.
- Heat-treated beryllium copper locking springs assure proper locking and alignment of contacts in the housing.
- Colour coded for different wire sizes.
- Closed entry design on socket contact to prevent probe damage.
- Contacts available in bulk packing

Performance characteristics

Current rating:	13 Amp
Contact resistance:	≤ 3 mΩ
Operating voltage:	750 V RMS
Contact retention in body:	110 N min.
Individual insertion force:	3.5 N max.
Individual withdrawal force:	0.55 N min.

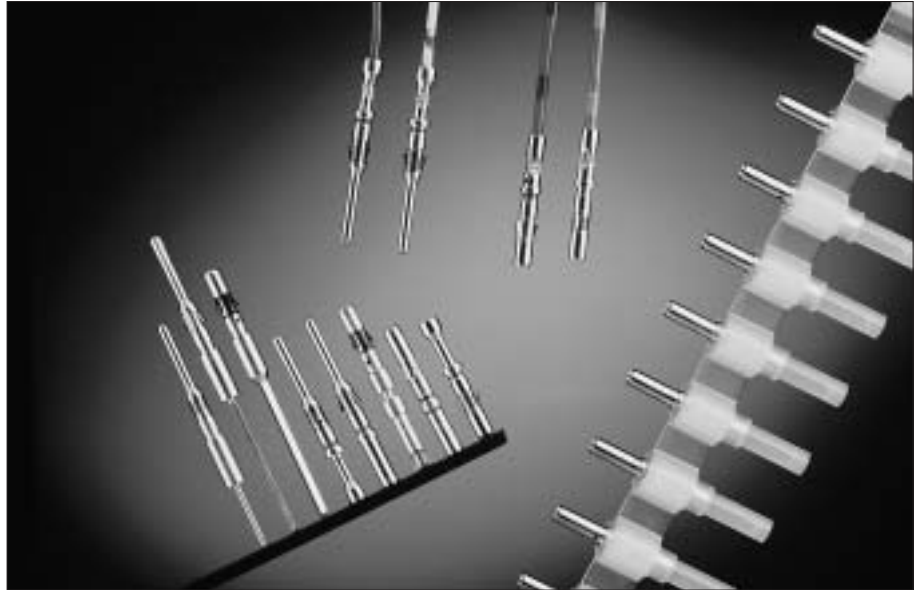

Construction

Contact body: High conductive copper alloy.

Outer spring: Tempered, heat-treated, non-plated beryllium copper.

Inner spring socket: Tempered, heat-treated, plated beryllium copper.

Connector accommodation

Any TRIM TRIO contact can be used in any contact position in any connector in the TRIM TRIO interconnection system.

- MS-M Rectangular connectors
- SMS Qikmate
- PI43 Eurorack connectors
- G-Bantamate
- UTG Metalok bantam
- UTP Full plastic bantam
- UTGS Shielded bantam
- MBG Bantamate II

How to order

	(C) RM	16	M	23	D28
	(C) RC	16	M	23	
Contact type:	RM:	Male contact bulk packing			
	RC:	Female contact bulk packing			
	CRM:	Male contact on plastic carrier strip			
	CRC:	Female contact on plastic carrier strip			
AWG Size:		16, 20, 24, 28, 30			
Size 16:		.0625" (1.6mm) Diameter contacts			
Design variation:		Crimp barrel			
Plating indication:					



Standard RM/RC crimp contacts: Contact size 16 - Pin diameter 1.57mm (.062")

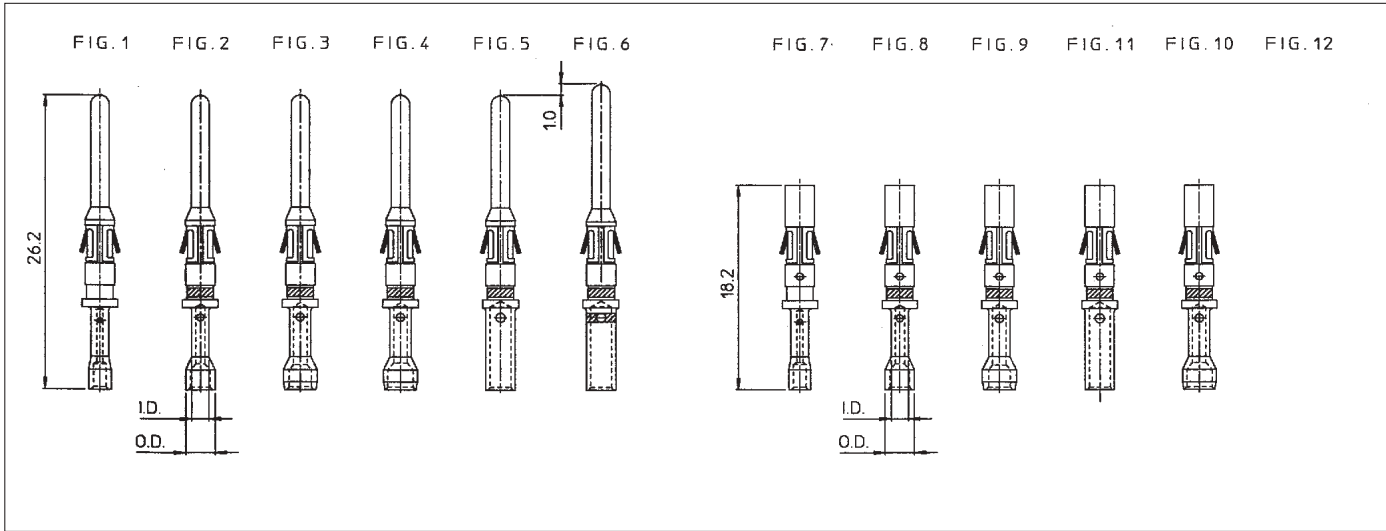

Dimensional table

Pin contacts	Part number		Fig.	wire size		Max. wire dia.	Max. insul. dia.	wire strip length	I.D.	O.D.
	Fig.	Socket contacts		AWG	mm ²					
RM28M1D28	1	RC28M1D28	7	30 - 28	0.05 - 0.08	0.55	1.1	4.8	1.50	1.90
RM24M9D28	2	RC24M9D28	8	26 - 24	0.13 - 0.20	0.8	1.7		1.50	2.55
RM20M13D28	3	RC20M13D28	9	22 - 20	0.32 - 0.52	1.18	1.9		1.83	2.92
RM20M12D28	4	RC20M12D28	10	22 - 20	0.32 - 0.52	1.18	2.2		1.83	2.92
RM16M23D28	5	RC16M23D28	11	20 - 16	0.52 - 1.50	1.82	3.2	7.1	2.55	-
RM16M31D28	6			20 - 16	0.52 - 1.50	1.82	3.2		2.55	-

Crimptooling table

Size	Hand crimp tooling for loose contacts			Extraction tools
	M10S1		M8ND	
	Die set (not incl.)	Stop bushing (not incl.)	Die set (not incl.)	
28	S9	SL40	N24RT10	RX16D11D1 or RX20-25GE1
24			N20RT30	
20	S10	SL39	N16RT21	
16M23	S3D1	SL115	N16RT25	
16M31	S3D1			



Special RM / RC contacts: Contact size 16 - Pin diameter 1.57mm (.062")

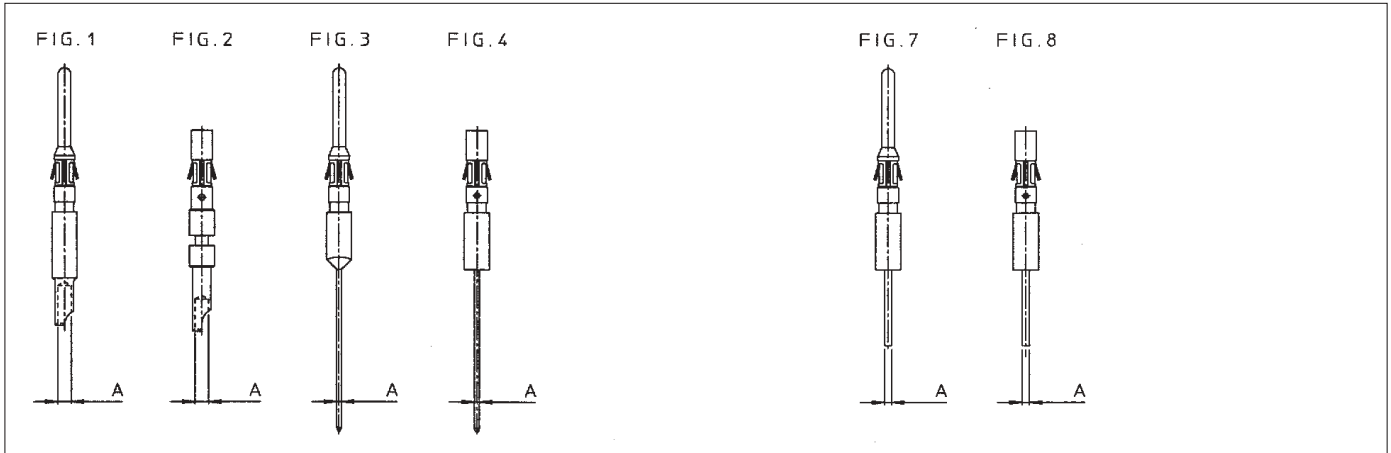

Pin contacts	Part number		Fig.	code	wire size		Post cross section A cavity	Length out of TRIM TRIO part number	Anti-rotating bushing
	Fig.	Socket contacts			AWG	mm ²			
RM16SEOK	1	RC16SE4K	2	Handsolder	16 - 20	1.50 - 0.52	∅1.7	3.5	-
RM20M12G4D28	3	RC20M12G4D28	4	Mini - wrap	28 - 30	0.08 - 0.05	∅ 0.636	16.0	J1661
RM20M12G8D28	7	RC20M12G18D28	8	Dipsolder	-	-	∅ 0.9	5.2	-

The RM/RC contact principle

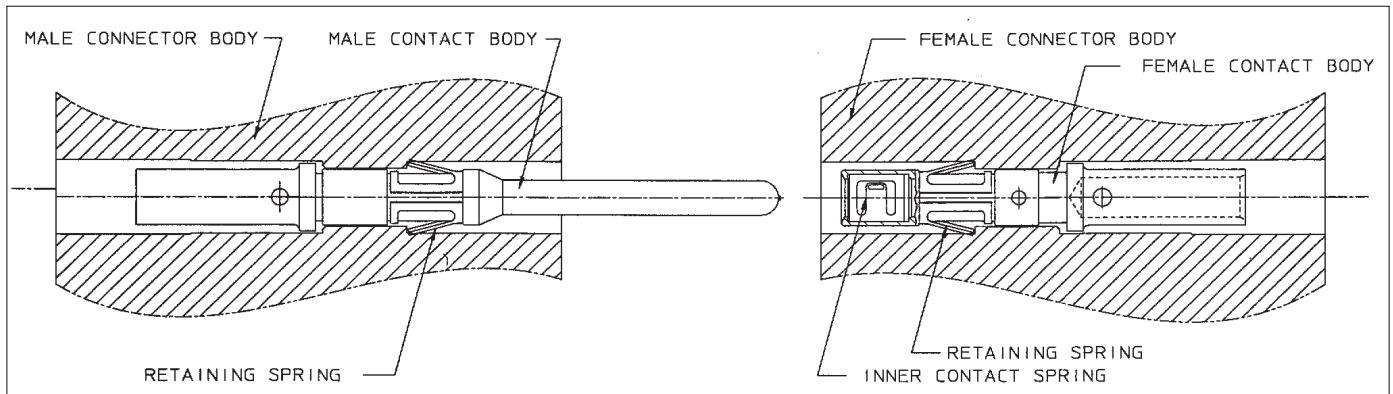



Size 16 stamped and formed contacts for TRIM TRIO connectors

Description

Size 16 SM/SC .0625" (1.6mm) diameter contacts are two piece strip formed crimp snap-in pin and sockets. These contacts consist of a crimp body made of high conductive copper alloy, and a stainless steel retaining spring featuring retention in the housing cavity and a closed entry socket to prevent probe damage. The contact with its open barrel is standard available on strip and packaged with 3000 pcs on reel. This reel packaging combined with semi or even full automatic crimp tooling provides the added advantage of a lower installed cost.

Features and benefits

- Made from high conductive copper alloy with gold or tin over nickel plate finish.
- Two piece construction with dual purpose spring which serves for contact retention and protects the body against damage.
- Contacts available on reel (standard) and in bulk packing (100 pcs).
- Suitable for high volumes and lower installation cost.

Performance characteristics

Current rating:	13 Amp
Contact resistance:	≤ 6 mΩ
Operating voltage:	750 V RMS
Contact retention in body:	65 N min.
Individual insertion force:	3.5 N max.
Individual withdrawal force:	0.55 N min.



Construction

Contact body: High conductive copper alloy.
Outer spring: Stainless steel

Plating table

S6 = 0.75 μ Gold min. in contact area, flash on crimp barrel over Nickel.
D70 = Gold flash all over, over Nickel.
TK6 = Preplated Tin all over.

Connector accommodation

Any TRIM TRIO contact can be used in any contact position in any connector in the TRIM TRIO interconnection system.

- MS-M Rectangular connectors
- SMS Qikmate
- PI43 Eurorack connectors
- G-Bantamate
- UTG Metalok bantam
- UTP Full plastic bantam
- UTGS Shielded bantam
- MBG Bantamate II

How to order

		SM	16	M	(L)	1	S6
		SC	16	M	(L)	1	S6
Contact type:	SM: Male contact SC: Female contact						
AWG Size:	14, 16, 20, 24						
Type of crimp barrel:	American open crimp barrel						
Packing:	No digit: Contacts on strip (qty 3000 per reel) L: Preformed loose piece contacts						
Design variation	1 : Only wire crimp for size 14 and 16 : Wire + insulation crimp for sizes 20 and 24 11 : Wire + insulation crimp for size 16						
Plating indication:	See plating table						



Standard SM/SC crimp contacts: Contact size 16 - Pin diameter 1.57mm (.062")

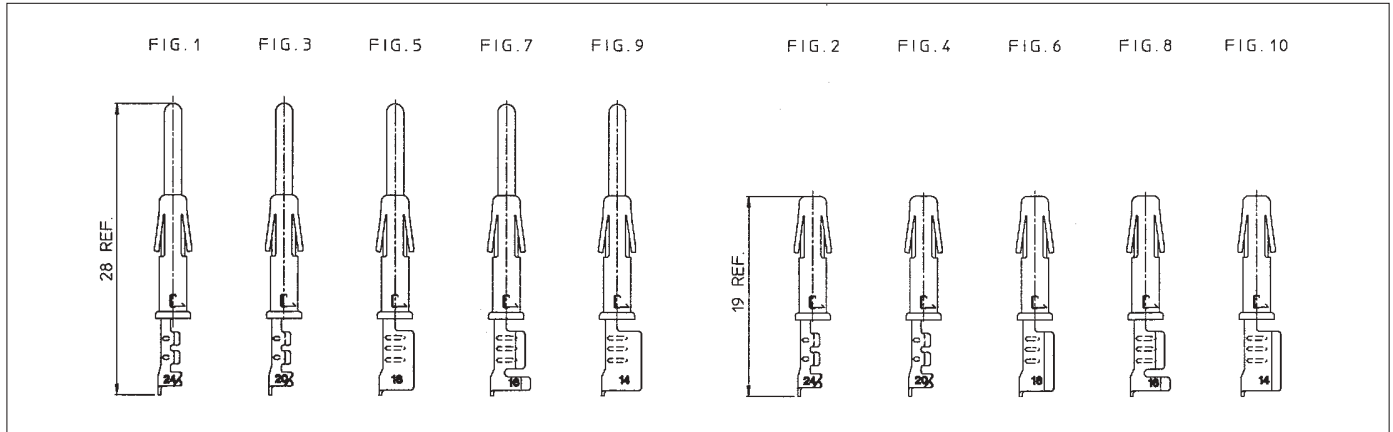

Dimensional table

Part number: contacts on strip Loose pieces				Wire size		Insulation diameter	Wire strip length
Pin contacts	Fig.	Socket contacts	Fig.	AWG	mm ²		
SM24M1S6 SM24ML1S6	1	SC24M1S6 SC24ML1S6	2	26 - 24	0.13 - 0.25	0.89 - 1.58	4.0
SM20M1S6 SM20ML1S6	3	SC20M1S6 SC20ML1S6	4	22 - 20	0.35 - 0.50	1.17 - 2.08	4.0
SM16M1S6 SM16ML1S6	5	SC16M1S6 SC16ML1S6	6	18 - 16	0.80 - 1.50	2.0 - 3.0	4.65
SM16M11S6 SM16ML11S6	7	SC16M11S6 SC16ML11S6	8	18 - 16	0.80 - 1.50	3.0	6.35
SM14M1S6 SM14ML1S6	9	SC14M1S6 SC14ML1S6	10	14	2.0	3.0	6.35

For other platings: See plating table.

Crimptooling table

Size	Hand crimp tooling for loose contacts		Automatic crimp tooling for contacts on strip UTM-2	Extraction tooling
	Hand tools die set included	M8ND Die set (not included)	Crimp Mechanism	
24	Y14MTV (ratchet)	N24RT11	CM11G1	RX16D11D1 or RX2025GE1
20		N20RT29		
16M(L)11		N16RT26	CM27	
16M(L)1		N16RT24	CM11	
14		N14RT13		

For detailed information on crimp tooling : See crimp tooling section



Size 16 MULTIPIECE coaxial contacts for TRIM TRIO connectors

Description

Size 16 RMDX/RCDX Multipiece .0625" (1.6mm) diameter contacts are subminiature coaxial contacts to cover a wide range of subminiature coaxial and twisted pair cables.

They are suitable in applications where a mix of signal, power and coaxial cable terminations for low frequency, shielded signal and high frequency applications are needed.

The contact consist of an inner pin/socket and an outer male/female body.

The thermoplastic insulating bushing in the outer body is designed to accept and permanently retain the inner contact.

The outer ferrule hold the outer braid to the outer contact and act as an insulating support to ensure against bending and vibrating stresses.

The inner and the outer conductor are crimped individually, thereby enabling inspection of both critical crimp points.

Features and benefits

- The inner and outer conductors are crimped individually
- The thermoplastic insulating bushing in the outer body is designed to accept and permanently retain the inner contact.
- Outer ferrule hold the outer braid to the outer contact and act as an insulating support to ensure against bending and vibration.

Performance characteristics

Operating voltage between inner / outer contact:	230 VDC
Test potential between inner / outer contact	750 VAC 1 min.
Operating temperature:	-55°C t0 + 125°C
Contact retention in body:	65 N min.
Contact voltage drop a 1A:	25m V max.
Shielding eff. at 30 MHZ:	140 db.

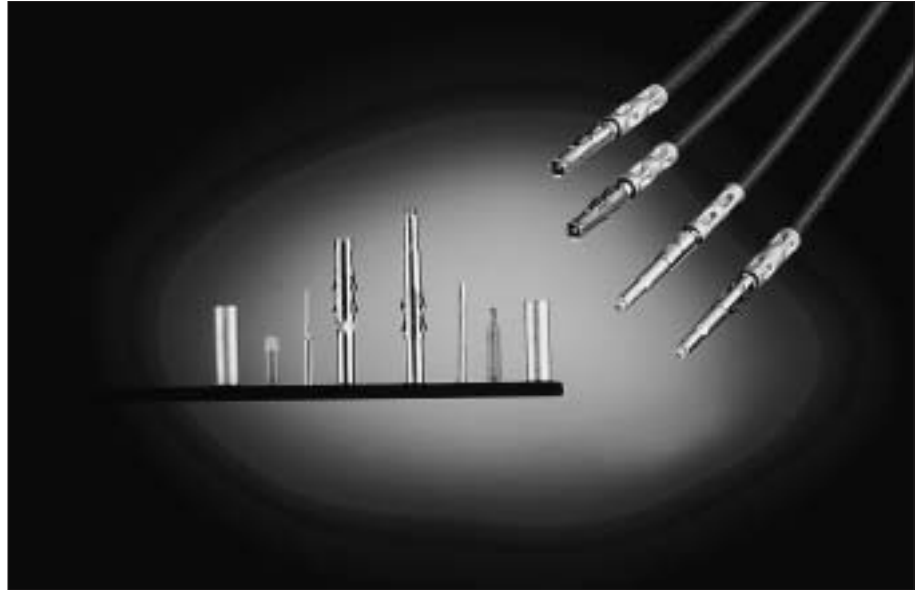

Construction

Inner and outer contacts: High conductive copper alloy

Retaining spring: beryllium copper

Insulating bushing: Polyamide 6.6

Plating table

Retaining spring: Nickel plated

Inner and outer contacts:

D28: 0.75 μ Gold min. over Nickel

Connector accommodation

Any TRIM TRIO contact can be used in any contact position in any connector in the TRIM TRIO interconnection system.

- MS-M Rectangular connectors
- SMS Qikmate
- PI43 Eurorack connectors
- G-Bantamate
- UTG Metalok bantam
- UTP Full plastic bantam
- UTGS Shielded bantam
- MBG Bantamate II

How to order

	RMDX RCDX	K10 K1	D28 D28
Contact type:	RMDX = Male subminiature coax. RCDX = Female subminiature coax.		
Multipiece coax kit	K10 = Kit male coax. K1 = Kit female coax		
Plating indication			



MULTIPIECE Subminiature coax - Male contact for coaxial cable

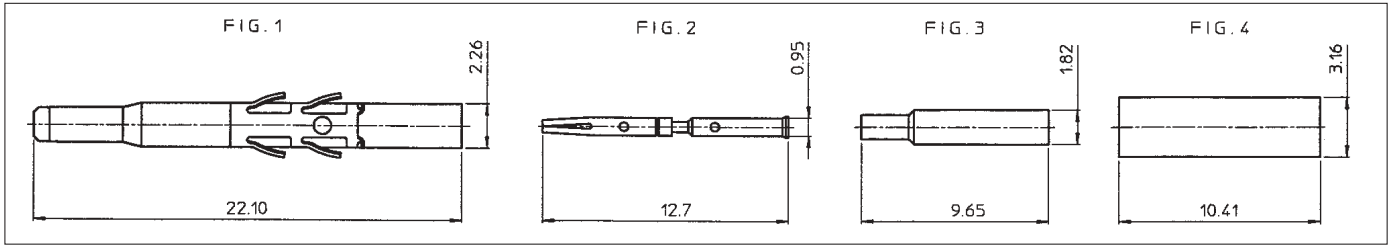

Type of coaxial cable	Contact for inner conductor				Contact for outer braid					Extrac tool	
	Inner female contact		Crimp tool M1051		Outer female contact		Hyring		Crimp tool M1051		
	Part number	Fig.	Stop Bushing	Die set	Part number	Fig	Part number	Fig	Stop Bushing		Die set
RG161U RG179A/U RG179B/U RG187U	RFD26L1D28	2	SL46D2	S23D2	RMDX602D28	1	YOC074	4	SL47-1	S22-1	RX2025 GE1 or RX16D11D1
S26D2				YOC074			4				
S23D2				YOC074 + RMDXB0553			4 3				

Kit reference RMDXK10D28 includes RMDX602D28 + RFD26L1D28 + YOC074 + RMDXB0553 and are packed in plastic bag.

MULTIPIECE Subminiature coax - Female contact for coaxial cable

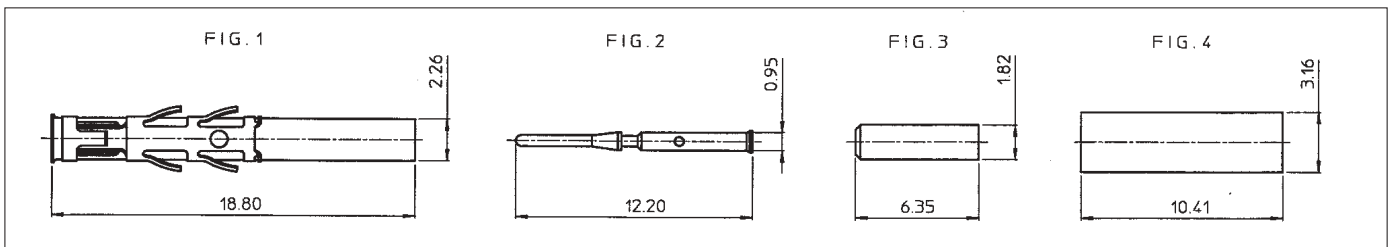

Type of coaxial cable	Contact for inner conductor				Contact for outer braid					Extrac tool	
	Inner female contact		Crimp tool M1051		Outer female contact		Hyring		Crimp tool M1051		
	Part number	Fig.	Stop Bushing	Die set	Part number	Fig	Part number	Fig	Stop Bushing		Die set
RG161U RG179A/U RG179B/U RG187U	RMD26L1D28	2	SL46D2	S23D2	RCDX602D28	1	YOC074	4	SL47-1	S22-1	RX2025 GE1 or RX16D11D1
S26D2				YOC074			4				
S23D2				YOC074 + RCDXB0551			4 3				

Kit reference RCDXK1D28 includes RCDX602D28 + RMD26L1D28 + YOC074 + RCDXB0551 and are packed in plastic bag.



MULTIPIECE Subminiature coax - Male contact for twisted pair cable

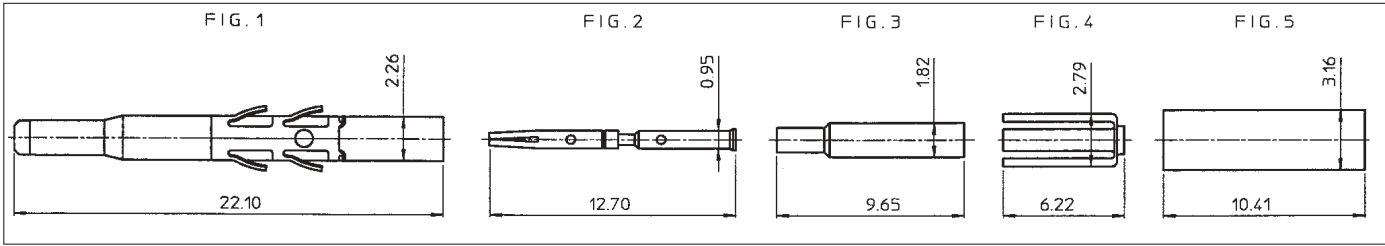

Type of coaxial cable	Contact for inner conductor				Contact for outer braid						Extrac tool
	Inner female contact		Crimp tool M10S1		Outer female contact		Hyring		Crimp tool M10S1		
	Part number	Fig.	Die set	Stop bushing	Part number	Fig	Part number	Fig	Die set	Stop bushing	
2 #24 solid or stranded 2 #26 str	RFD26L1D28	2	S26D2	SL46D2	RMDX602D28	1	YORX090	4	S221	SL471	RX2025 GE1
YOC074							5				
RMDXB0553							3				
2 #24 7/20 str. MIL-W-76 or MIL-W-16878 type B	RFD26L1D28	2	S26D2	SL46D2	RMDX602D28	1	YORX090	4	S221	SL471	or RX16D11D1
YOC074							5				
RMDXB0554							3				
#28 per MIL-W- 81822/3	RFD26L1D28	2	S26D2	SL46D2	RMDX602D28	1	YORX090	4	S221	SL471	or RX16D11D1
YOC074							5				
RMDXB0553							3				

MULTIPIECE Subminiature coax - Female contact for twisted pair cable

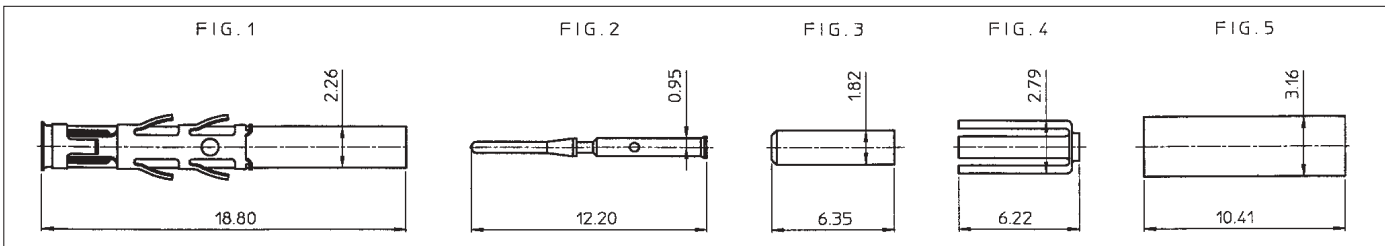

Type of coaxial cable	Contact for inner conductor				Contact for outer braid						Extrac tool
	Inner female contact		Crimp tool M10S1		Outer female contact		Hyring		Crimp tool M10S1		
	Part number	Fig.	Die set	Stop bushing	Part number	Fig	Part number	Fig	Die set	Stop bushing	
2 #24 solid or stranded 2 #26 str	RMD26L1D28	2	S26D2	SL46D2	RCDX602D28	1	YORX090	4	S221	SL471	RX2025 GE1
YOC074							5				
RCDXB0551							3				
2 #24 7/20 str. MIL-W-76 or MIL-W-16878 type B	RMD26L1D28	2	S26D2	SL46D2	RCDX602D28	1	YORX090	4	S221	SL471	or RX16D11D1
YOC074							5				
RCDXB0552							3				
#28 per MIL-W- 81822/3	RMD26L1D28	2	S26D2	SL46D2	RCDX602D28	1	YORX090	4	S221	SL471	or RX16D11D1
YOC074							5				
RCDXB0551							3				



Size 16 monocrimp coaxial contacts for TRIM TRIO connectors

Description

Size 16 RMDX/RCDX Monocrimp .0625" (1.6mm) diameter contacts are one-piece monocrimp subminiature coaxial contacts to cover a wide range of subminiature coaxial and twisted pair cables. They provide cost effective solutions in applications where a mix of signal, power and coaxial cable terminations for low frequency, shielded signal and high frequency applications are needed. Monocrimp one piece coaxial contacts offer high reliability plus the economic advantage of a 95% reduction in installation time over conventional assembly methods currently in use.

Features and benefits

- The monocrimp one-piece coaxial contacts offer high reliability plus the economic advantage of a 95% reduction in installation time over conventional assembly methods.
- This economy is achieved by simultaneously crimping of both the inner and outer conductor

Performance characteristics

Operating voltage between inner / outer contact:	230 VDC
Test potential between inner / outer contact	450 VAC 1 min.
Operating temperature:	-55°C to + 125°C
Contact retention in body:	65 N min.
Contact voltage drop a 1A:	30m V max.
Shielding eff. at 30 MHZ:	140 db.

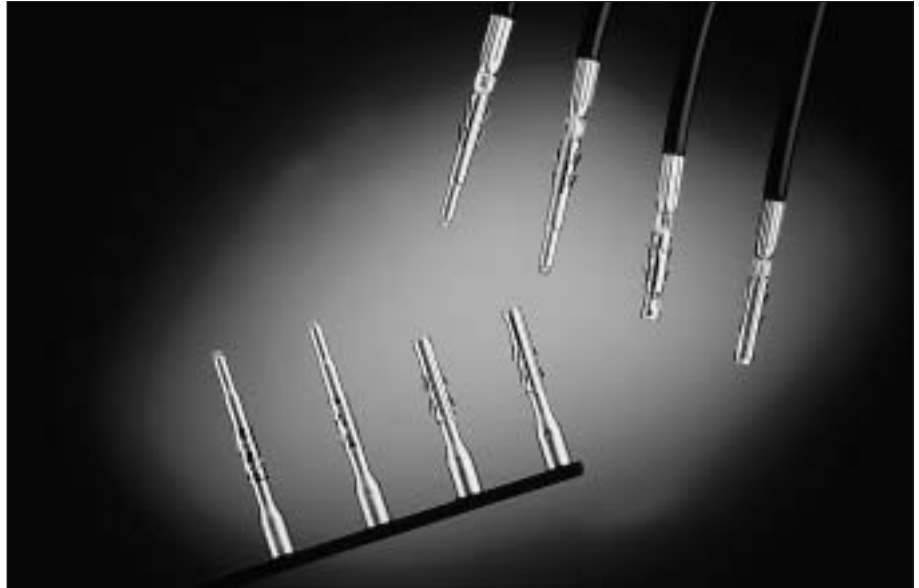

Construction

Inner and outer contacts:	High conductive copper alloy
Retaining spring:	beryllium copper
Insulating bushing:	Polyamide 6.6

Plating table

Retaining spring:	Nickel plated
Inner and outer contacts:	D28: 0.75µ Gold min. over Nickel

Connector accommodation

- Any TRIM TRIO contact can be used in any contact position in any connector in the TRIM TRIO interconnection system.
- MS-M Rectangular connectors
 - SMS Qikmate
 - PI43 Eurorack connectors
 - G-Bantamate
 - UTG Metalok bantam
 - UTP Full plastic bantam
 - UTGS Shielded bantam
 - MBG Bantamate II

How to order

	RMDX60 RCDX60	36 36	D28 D28
Contact type:	RMDX = Male subminiature coax. RCDX = Female subminiature coax.		
Monocrimp design variation			
Plating indication			

RMDX/RCDX



MONOCRIMP Twisted pair

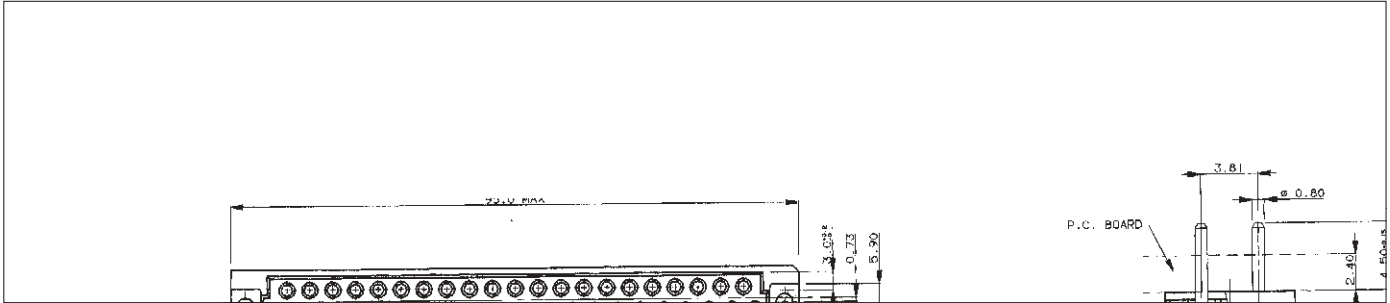

Part number		AWG inner conduct.	Dia. outer jacket (single wire)	Cable strip lengths			Crimp tool M10S1		Extraction tool
Male	Female			A	B	C	Die set not incl.	Stop bushing not. incl.	
RMDX6019D28	RCDX6019D28	26 (19 x 0.10)	1.25	4.7	6.0	4.0	M10SG8* Crimping kit		RX2025GE1 or RX16D11D1
		24 (7 x 0.20)	1.25						
		24 (19 x 0.13)	1.45						
RMDX6031D28	RCDX6031D28	26 (7 x 0.16)	0.70				S80	SL105	

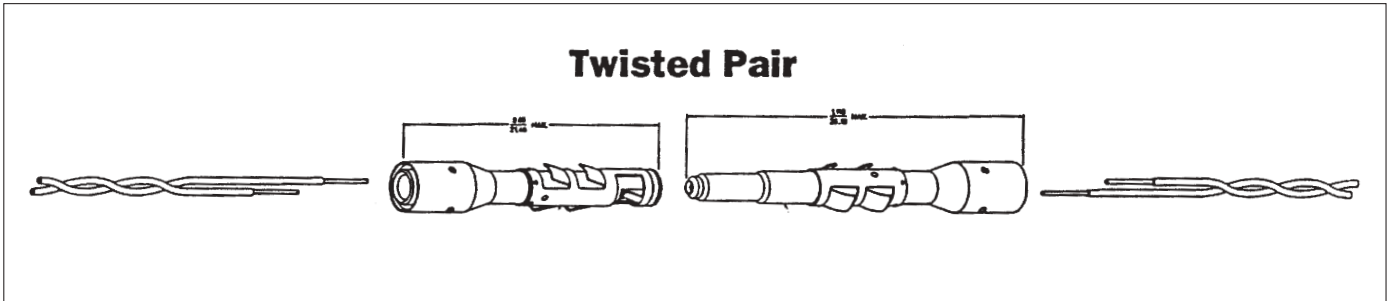



MONOCRIMP Subminiature coax

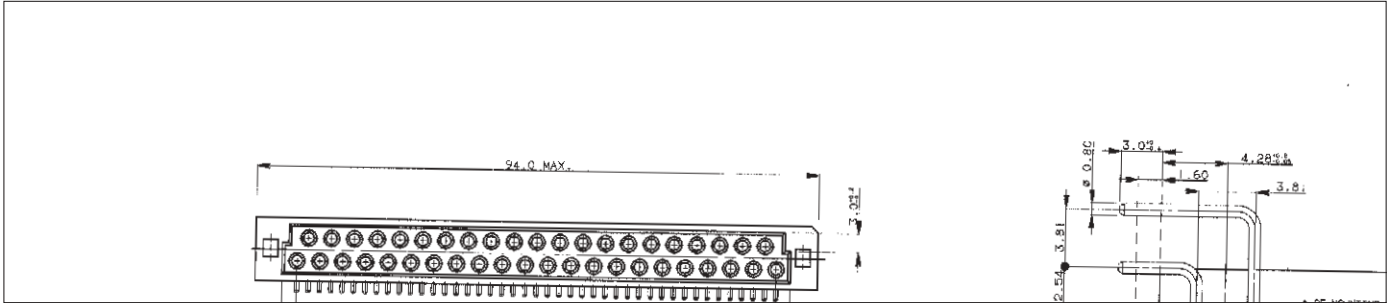

Part number	AWG inner conduct.	Cable type	Coax dimensions				Coax strip lengths			Crimp tool M10S1		Extraction tool
			D max	E	F	G	A	B	C	Die set not incl.	stop bushing not incl.	
RMDX6050D28 RCDX6016D28	30	-	2.64	2.11	1.70	0.30	5.1	6.35	8.9	S80	SL105	RX2025GE1 OR RX16D11D1
RMDX6050D28 RCDX6016D28		-	2.29	1.63	1.22	4.2	8.5		S87			
RMDX6032D28 RCDX6032D28	28	-	2.90	2.29	1.91	0.38	5.1		11.7	S80		
RMDX6032D28 RCDX6032D28	26	RG174/U	2.92	2.24	1.52	0.48			11.7	S80		
RMDX6026D28 RCDX6026D28		-	3.05	2.44	1.96	0.41				S82		
RMDX6036D28 RCDX6036D28		RG188A/U	2.79							S80		
RMDX6036D28 RCDX6036D28		RG316/U	2.72	1.98	1.52	0.51						

* M10SG8 consists of die set, stop bushing and M10S1 tool

Submin Coax

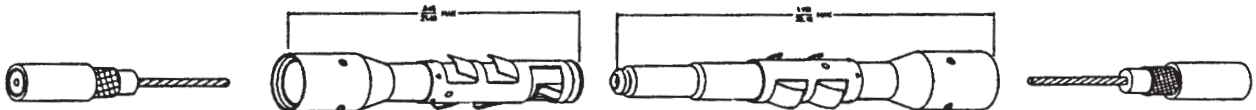



New

Size 20 stamped and formed contacts for SEALOK connectors

Description

Size 20 SM-W/SC-W .040" (1.0mm) diameter contacts are two piece strip formed crimp snap-in pin and sockets. These contacts consist of a crimp body made of high conductive copper alloy, and a stainless steel retaining spring featuring retention in the housing cavity and a closed entry socket to prevent probe damage. Contacts accommodate AWG20 through AWG26 wire and the crimp barrels are identical to the crimp barrels used on the TRIM TRIO contact thus offering the advantage of using the same crimp tooling. The contact with its open barrel is standard available on strip and packaged with 3000 pcs on a reel. This reel packaging combined with semi or even full automatic crimp tooling provides the added advantage of a lower installed cost. Each contact has a break-off section facilitating the use of handtooling and individual crimping.

Features and benefits

- Made from high conductive copper alloy with gold or tin over nickel plate finish.
- Two piece construction with dual purpose spring which serves for contact retention and protects the body against damage.
- Contacts available on reel (3000 pcs) and in bulk packing (100 pcs)
- Crimp tooling is the same as used on TRIM TRIO contacts.



Performance characteristics

Current rating:	5 Amp
Contact resistance:	≤ 15 mΩ
Dielectric withstanding voltage:	1500 V RMS min
Contact retention in body:	90 N max.
Contact engagement force:	5 N max.
Contact separation force/	2 N min.

Construction

Contact body:	High conductive copper alloy.
Outer spring:	Stainless steel

Plating table

S25/26	= 0.75μ Gold min. in contact area, gold flash on crimp barrel over Nickel.
TK6	= Preplated Tin all over.

Connector accommodation

Any SEALOK SM-W / SC-W contact can be used in any contact position in any connector in the SEALOK interconnection system.

- UTGW Sealok

How to order

		SM	24	W	(L)	3	S26
		SC	24	W	(L)	3	S25
Contact type:	SM: Male contact SC: Female contact						
AWG Size:	20, 24						
Type of crimp barrel:	Open crimp barrel identical to TRIM TRIO						
Packing:	No digit: Contacts on strip (qty 3000 per reel) L: Preformed loose piece contacts (qty 100 in plastic bag)						
Design variation							
Plating indication:	See plating table						



New

Standard SM-W/SC-W crimp contacts: Contact size 20 - Pin diameter 1.0mm (.040")

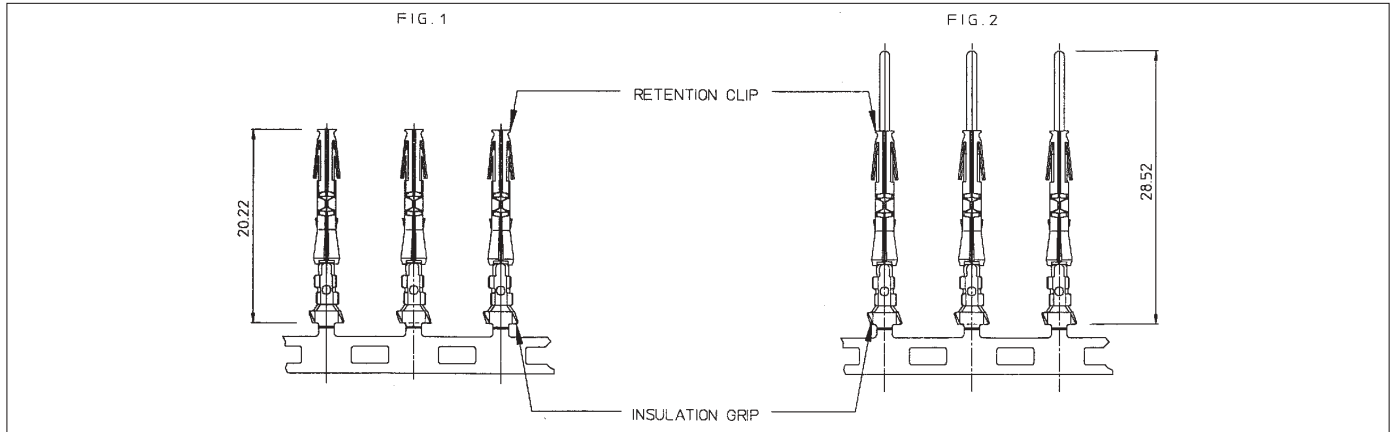

Dimensional table

Part number: contacts on strip Loose pieces				Wire size		Insulation diameter	Wire strip length
Pin contacts	Fig.	Socket contacts	Fig.	AWG	mm ²		
SM24W3S26 SM24WL3S26	2	SC24W3S25 SC24WL3S25	1	26 - 24	0.13 - 0.25	0.89 - 1.58	4.0
SM20W3S26 SM20WL3S26	2	SC20W3S25 SC20WL3S25	1	22 - 20	0.35 - 0.50	1.17 - 2.08	4.0

For other platings: See plating table

Crimptooling table

Size	Hand crimp tooling for loose contacts		UTM-2 Crimp Mechanism	Extraction tooling
	Hand tools die set included	M8ND Die set (not included)		
24	Y14MTV (ratchet)	N24RT14	CM11G1	RX20D44
20		N20RT33		

For detailed information on crimp tooling : See crimp tooling section.

* without locator



New

Size 16 Fibre optic contacts for TRIM TRIO connectors

Description

Size 16 (1.6mm) Fibre optic contacts series 8012 are optical contacts designed for the integration of optical links in all TRIM TRIO cable connectors.

The F.O. contacts are designed to accommodate 1000µ plastic fibres with a cable diameter of 2.2 mm.

Features and benefits

- Socket contact is spring loaded to avoid any air gap between the two optical faces.
- Low insertion loss is provided by high precision pieces.
- Single jumpers, multiway harness and active device housings can be supplied according customer requirement.

Performance characteristics for plastic fibre (depends on supplier)

Temperatur range:	-20°C to + 70°C
Attenuation at 0.660 µm (at +20°C):	< 200 db/Km
Min radius:	25 mm
Tensile strength	5 daN
Weight:	5 daN/Km
Cable retention:	25 N
Typical insertion loss	1.5 dB at 650 nm

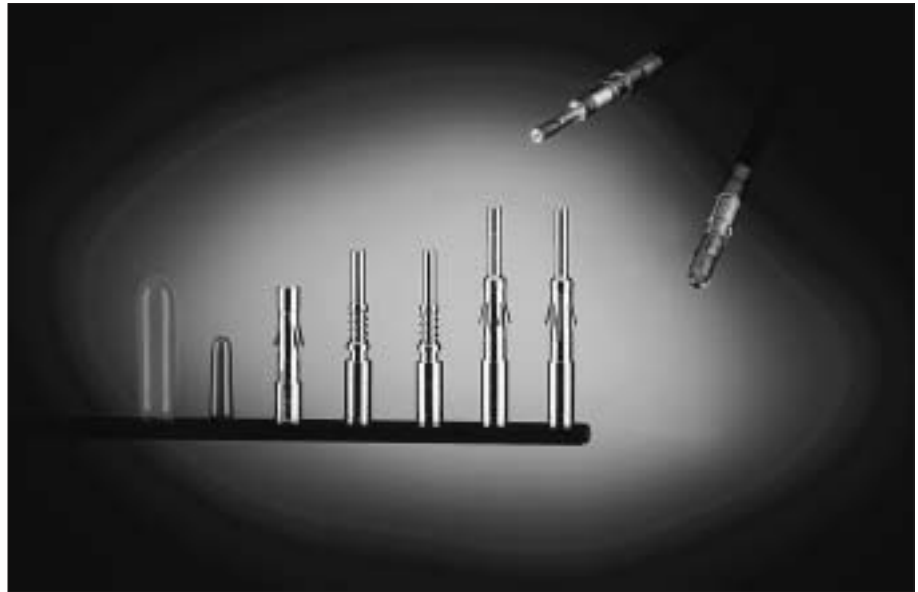

Construction

Contact body: Arcap (rustproof)
Outer spring: Stainless steel

Connector accommodation

Fibre optic contacts can be used in any contact position in any connector in the TRIM TRIO interconnection system.

- MS-M Rectangular connectors
- SMS Qikmate
- PI43 Eurorack connectors
- UT-Bantam
- UTG Metalok bantam
- UTP Full plastic bantam
- UTGS Shielded bantam

How to order

Contacts

Male contact: 8012P14J262
Female contact: 8012S14J262

Tool kit

Crimping / polishing technic

The tool kit contains all necessary tools to terminate contacts for plastic fibre, such as

- Stripping plier
- Crimping plier
- Polishing plate and tool
- Miscellaneous

Part number tool kit: 80MS0004

Separate tools

• Cutting tool	80WD0005
• Stripping plier	80WD0025
• Crimping plier	80WS0002
• Polishing plate	80WP0005
• Polishing tool	80WP0018
• 10 polishing disks 30 µm	80WP0019
• 10 polishing disks 9 µm	80WP0014
• Extraction tool	RX2025GE1

For other fibres consult factory.



Discrimination keys for TRIM TRIO connectors

Description

In applications where similar connectors are used next to each other, mismatching can be a reason for disturbances, system failure or even danger to operating personnel. To eliminate mismatching, all TRIM TRIO connectors can be equipped with discrimination keys, which offer unlimited possibilities for a "fool - proof" interconnection system.

When one of these discrimination keys is used, the TRIM TRIO connector will only mate with a connector which has a vacant contact or discrimination cavity at the corresponding position.

This system offers boundless opportunities for all applications which involve several identical TRIM TRIO connectors.

The material used is polyamide 6.6

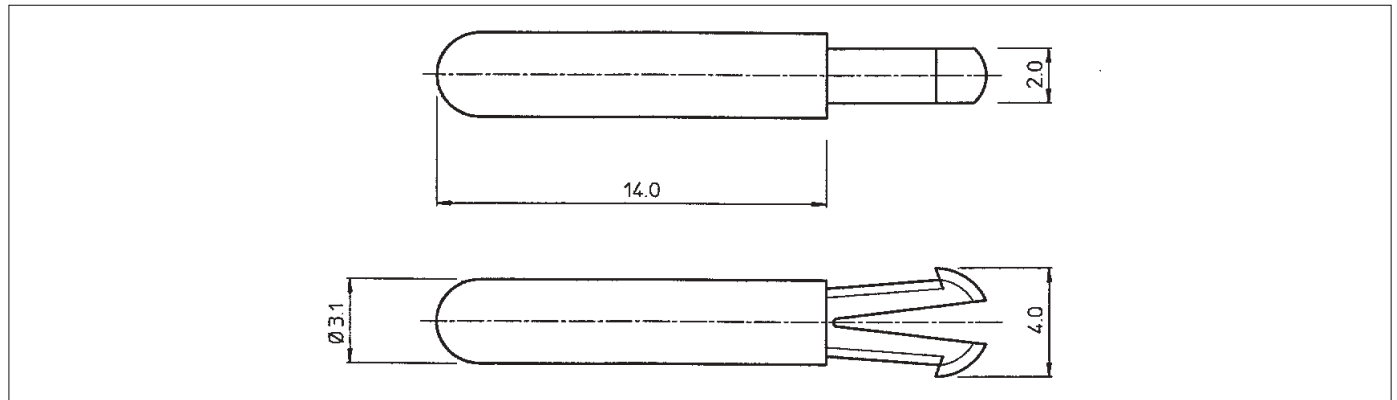
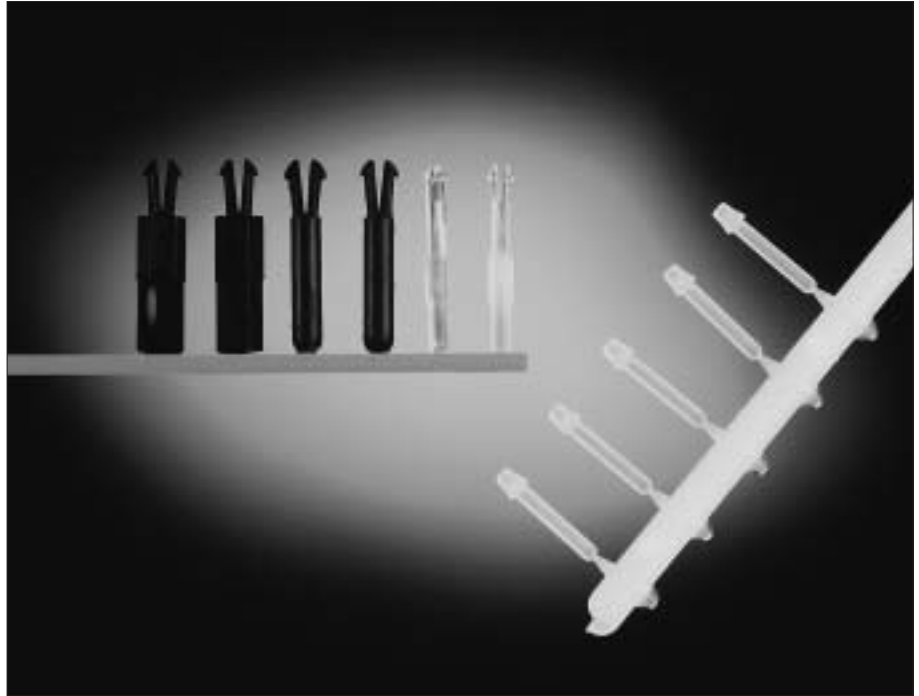

SMSPKB1-5PK

A dummy contact, which can be inserted into an empty contact cavity in any of the TRIM TRIO connectors.

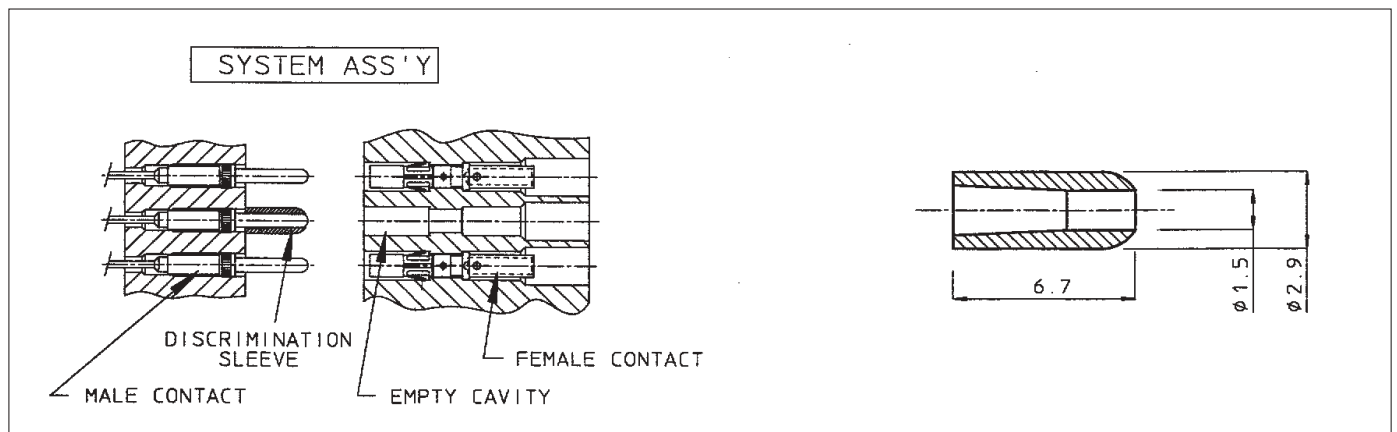

SMSPKB2

A tube, which can be fitted over a preassembled male contact in all TRIM TRIO male boardmount connectors MSO, SMS, PI43.

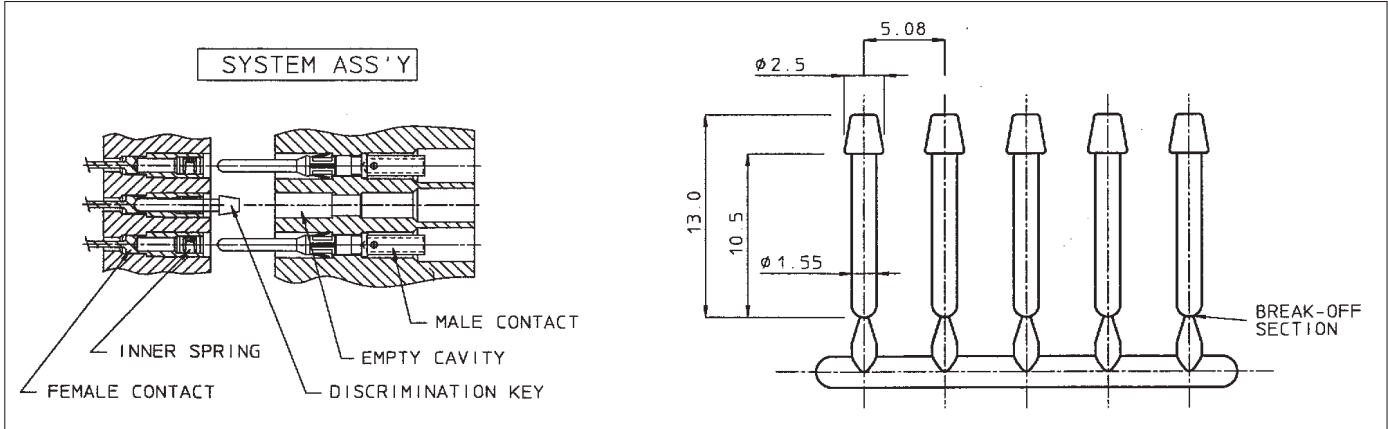

SMSPK2V1

A pin, which can be inserted into a preassembled female contact in all TRIM TRIO female boardmount connectors MSO, SMS, PI43.

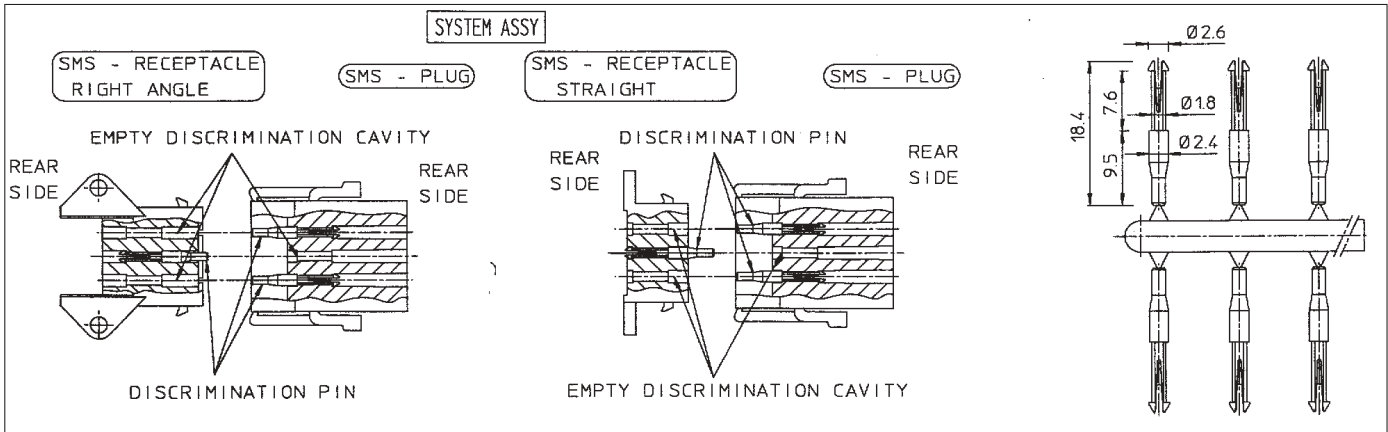

SMSPK3

A pin, which can be inserted in the discrimination cavities of the SMS Qikmate cable and boardmount connectors. The discrimination cavities are in between of the contact cavities and offer the advantage that no contact cavities are lost due to discrimination.

As extraction tool, the RX2025GE1 without the "extraction tool tip" can be used.

To unlock the discrimination pin, insert the extraction tool in the discrimination cavity at the rear side of the connector. Meanwhile, the pin can be extracted manually at the mating side.



Overview TRIM TRIO and SEALOK tooling



Selection matrix TRIM TRIO and SEALOK tooling

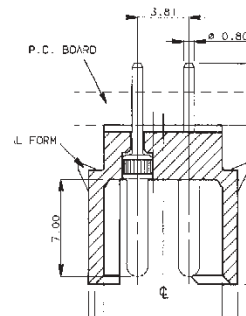
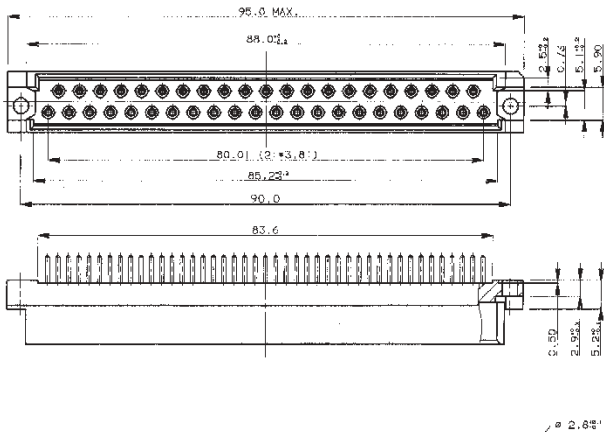



Weight: 425 gr.
Length: 250 mm.

M10S1 - for machined contacts

A robust, versatile, full cycling handtool which is fully qualified to the requirements of MIL-C-22520. Interchangeable 4-indent die sets are available for a wide range of machined contacts and gives a simultaneous crimp on both wire and insulation.

This tool is suitable for application of RM/RC machined contacts and coaxial from the TRIM TRIO range.



Weight: 800 gr.
Length: 275 mm.

M8ND - for machined and formed contacts

A robust full cycling hand ratchet tool which utilises interchangeable "N" die sets to crimp

Size 16 TRIM TRIO RM/RC loose piece machined contacts.

Size 16 TRIM TRIO SM-M/SC-M loose piece formed contacts.

Size 20 SEALOK SM-W/SC-W loose piece formed contacts.



Weight: 400 gr.
Length: 230 mm.

Y14MTV - for formed contact

A light weight crimping tool with fixed 3-groove die set for AWG26 to 14 for:

Size 16 TRIM TRIO SM-M/SC-M loose piece formed contacts.

Size 20 SEALOK SM-W/SC-W loose piece formed contacts.

Ratchet controlled to guarantee a complete crimp cycle.



Extraction tooling



RX2025GE1

A spring loaded extraction tool **for the full range of TRIM TRIO contacts**. This tool ensures that the contact locking louvres are fully retracted before any pressure is applied to extract a contact. It is especially suitable for applications where the integrity of the assemblies are of the utmost importance.



RX16D11D1

For use with all **TRIM TRIO contacts**. Must be used with Qikmate rectangular connectors.



RX20D44

A spring loaded extraction tool **for the full range of SEALOK contacts**. This tool ensures that the contact locking louvres are fully retracted before any pressure is applied to extract a contact. It is especially suitable for applications where the integrity of the assemblies are of the utmost importance.

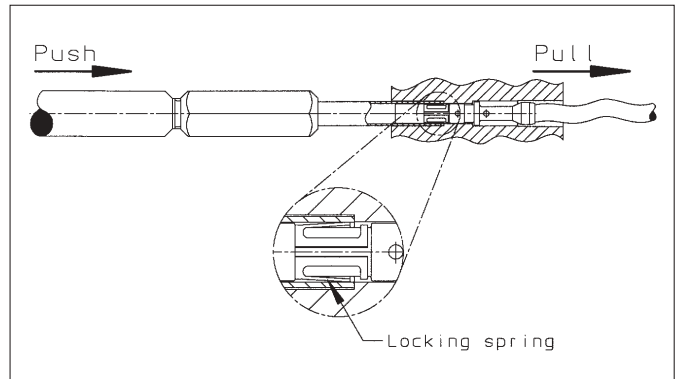

How to extract a contact out of its cavity?

Slide the extraction tip over contact from mating side till the locking spring from the contact is depressed.
Push on handle to push out the contact with the spring loaded inner plunger.

Insertion tooling



RTM205

This tool is especially designed to ease insertion of **any TRIM TRIO and SEALOK contact** crimped on very flexible or small wire sizes. Simply position the insertion tool so that the tip of the tool bears against the back of the wire barrel, retaining the wire with thumb in the groove of the tool. Push the contact slowly into the connector until it snaps into position.



Notes

A series of horizontal dotted lines for taking notes.



Notes

A series of horizontal dotted lines for taking notes.

U.S.A. Tel.: (800) 237-2374; 717-938-7200
Canada Tel.: 905-826-9810
Europe Tel.: 33-1-39-49-21-83
Asia/Pacific Tel.: 65-549-6666

