



# 1 Absolute maximum ratings and operating conditions

**Table 1. Absolute maximum ratings (AMR)**

Symbol	Parameter	Value	Unit
$V_{CC}$	Supply voltage	$\pm 18$ or 36	V
$V_{ID}$	Differential input voltage	$\pm 36$	V
$V_{in}$	Input voltage	-0.3 to +36	V
	Output short-circuit to ground <sup>(1)</sup>	20	mA
$R_{thja}$	Thermal resistance junction to ambient <sup>(2)</sup> (SO-14)	105	°C/W
$R_{thjc}$	Thermal resistance junction to case <sup>(2)</sup> (SO-14)	31	°C/W
$T_j$	Maximum junction temperature	160	°C
ESD	HBM: human body model <sup>(3)</sup>	500	V
	MM: machine model <sup>(4)</sup>	100	
	CDM: charged device model <sup>(5)</sup>	1500	
$T_{stg}$	Storage temperature range	-65 to +150	°C

- Short-circuit from the output to  $V_{CC}^+$  can cause excessive heating and eventual destruction. The maximum output current is approximately 20 mA, independent of the magnitude of  $V_{CC}^+$
- Short-circuits can cause excessive heating and destructive dissipation. Values are typical.
- Human body model: A 100 pF capacitor is charged to the specified voltage, then discharged through a 1.5 kΩ resistor between two pins of the device. This is done for all couples of connected pin combinations while the other pins are floating.
- Machine model: A 200 pF capacitor is charged to the specified voltage, then discharged directly between two pins of the device with no external series resistor (internal resistor < 5 Ω). This is done for all couples of connected pin combinations while the other pins are floating.
- Charged device model: all pins and the package are charged together to the specified voltage and then discharged directly to the ground through only one pin. This is done for all pins.

**Table 2. Operating conditions**

Symbol	Parameter	Value	Unit
$V_{CC}^+$	Supply voltage	2 to 36	V
$T_{oper}$	Operating free-air temperature range	-40 to +150	°C
$V_{icm}$	Input common mode voltage range ( $V_{CC} = 30$ V) <sup>(1)</sup> $T_{amb} = +25^\circ\text{C}$ $T_{min} \leq T_{amb} \leq T_{max}$	0 to $V_{CC}^+ - 1.5$ 0 to $V_{CC}^+ - 2$	V

- The input common-mode voltage of either input signal voltage should not be allowed to go negative by more than 0.3 V. The upper end of the common-mode voltage range is  $V_{CC}^+ - 1.5$  V, but either or both inputs can go to +30 V without damage.

## 2 Circuit schematics

Figure 1. Schematic diagram (1/4 LM2901)

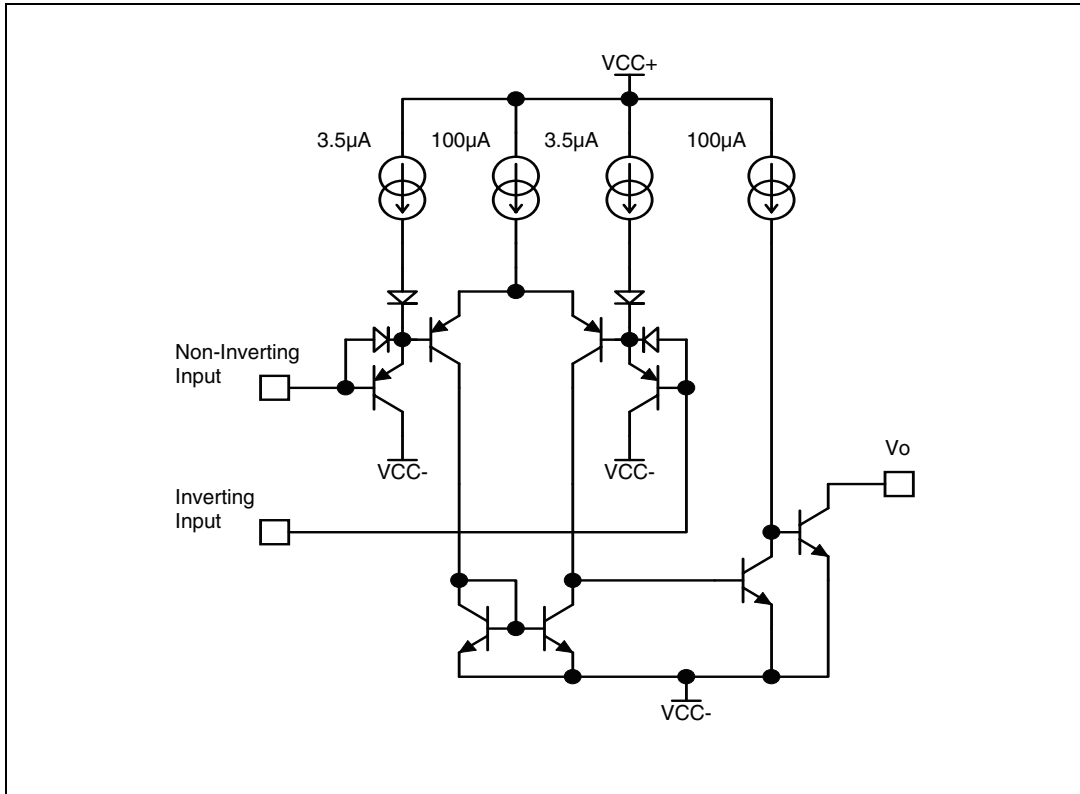
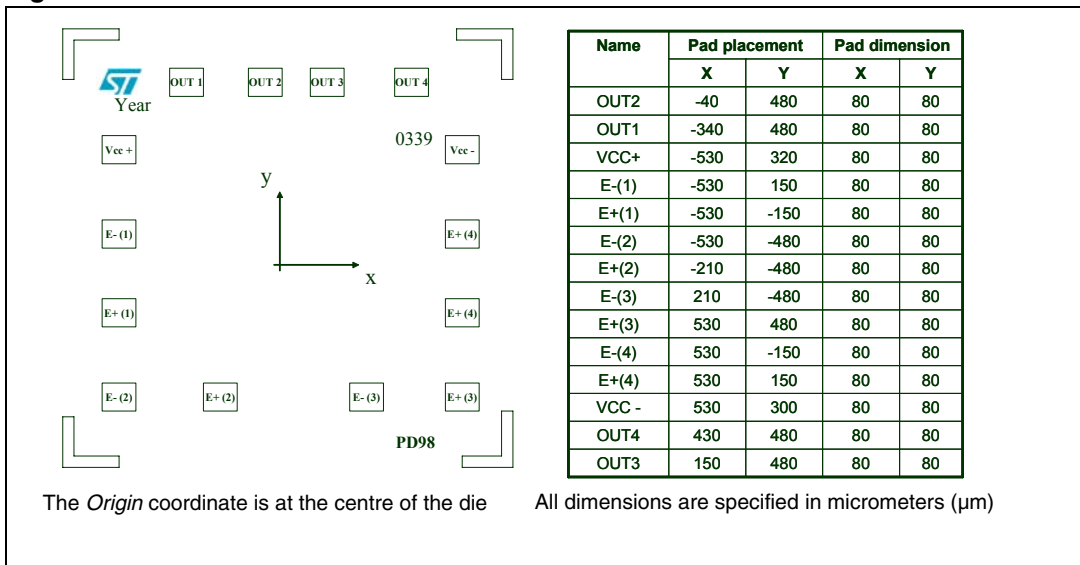

Figure 2. Pad locations



### 3 Electrical characteristics

**Table 3.**  $V_{CC}^+ = 5V$ ,  $V_{CC}^- = GND$ ,  $T_{amb} = 25^\circ C$  (unless otherwise specified)

Symbol	Parameter	Min.	Typ.	Max.	Unit
$V_{io}$	Input offset voltage <sup>(1)</sup> $T_{min} \leq T_{amb} \leq T_{max}$		1	7 15	mV
$I_{io}$	Input offset current $T_{min} \leq T_{amb} \leq T_{max}$		5	50 150	nA
$I_{ib}$	Input bias current ( $I_{I^+}$ or $I_{I^-}$ ) <sup>(2)</sup> $T_{min} \leq T_{amb} \leq T_{max}$		25	250 400	nA
$A_{VD}$	Large signal voltage gain $V_{CC}=15V$ , $R=15k\Omega$ , $V_o=1$ to $11V$	25	200		V/mV
$I_{CC}$	Supply current (all comparators) $V_{CC} = +5V$ , no load $V_{CC} = +30V$ , no load		1.1 1.3	2 2.5	mA
$V_{ID}$	Differential input voltage <sup>(3)</sup>			$V_{CC}^+$	V
$V_{OL}$	Low level output voltage $V_{id} = -1V$ , $I_{sink} = 4mA$ $T_{min} \leq T_{amb} \leq T_{max}$		250	400 700	mV
$I_{OH}$	High level output current $V_{CC} = V_o = 30V$ , $V_{id} = 1V$ $T_{min} \leq T_{amb} \leq T_{max}$		0.1	1	nA $\mu A$
$I_{sink}$	Output sink current $V_{id} = -1V$ , $V_o = 1.5V$ $T_{min} \leq T_{amb} \leq T_{max}$	6 2	16		mA
$t_{re}$	Small signal response time <sup>(4)</sup> $R_L = 5.1k\Omega$ connected to $V_{CC}^+$		1.3		$\mu s$
$t_{rel}$	Large signal response time <sup>(5)</sup> TTL input, $V_{ref} = +1.4V$ , $R_L = 5.1k\Omega$ to $V_{CC}^+$ – Output signal at 50% of final value – Output signal at 95% of final value			500 1	ns $\mu s$

1. At output switch point,  $V_o \approx 1.4V$ ,  $R_S = 0$  with  $V_{CC}^+$  from 5V to 30V, and over the full input common-mode range (0V to  $V_{CC}^+ - 1.5V$ ).
2. The direction of the input current is out of the IC due to the PNP input stage. This current is essentially constant, independent of the state of the output, so there is no load on the reference of input lines
3. The response time specified is for a 100 mV input step with 5 mV overdrive.
4. Positive excursions of input voltage may exceed the power supply level. As long as the other voltage remains within the common-mode range, the comparator will provide a proper output state. The low input voltage state must not be less than  $-0.3V$  (or 0.3V below the negative power supply, if used).
5. Maximum values are guaranteed by design.

Figure 3. Supply current vs. supply voltage

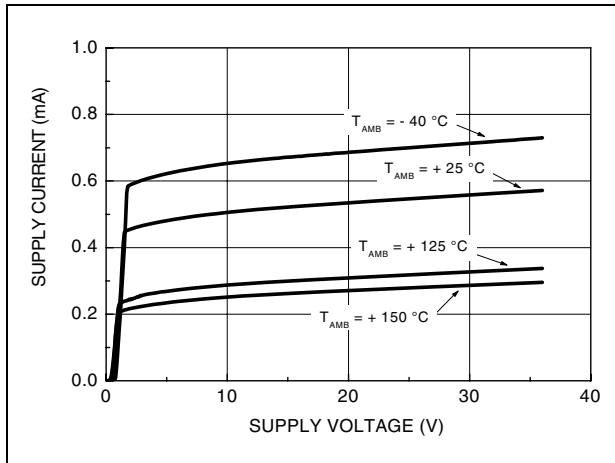

Figure 4. Input current vs. supply voltage

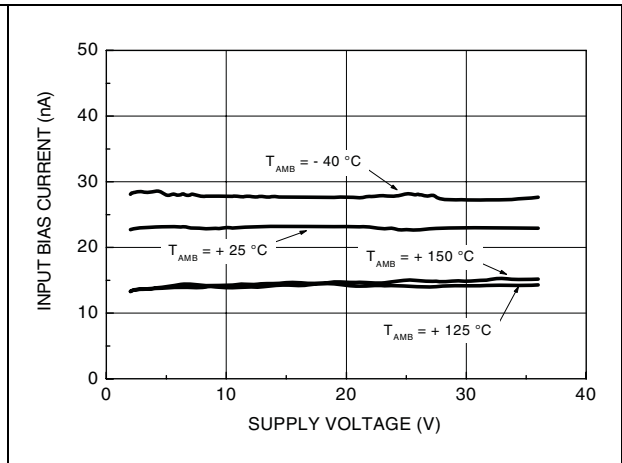

Figure 5. Output saturation voltage vs. output current ( $V_{CC} = 5\text{ V}$ )

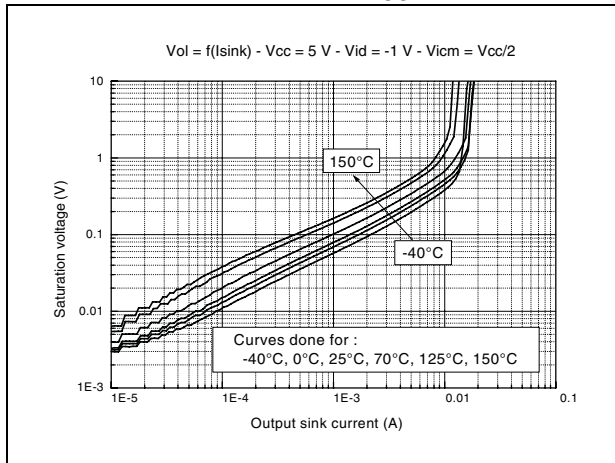

Figure 6. Output saturation voltage vs. output current ( $V_{CC} = 30\text{ V}$ )

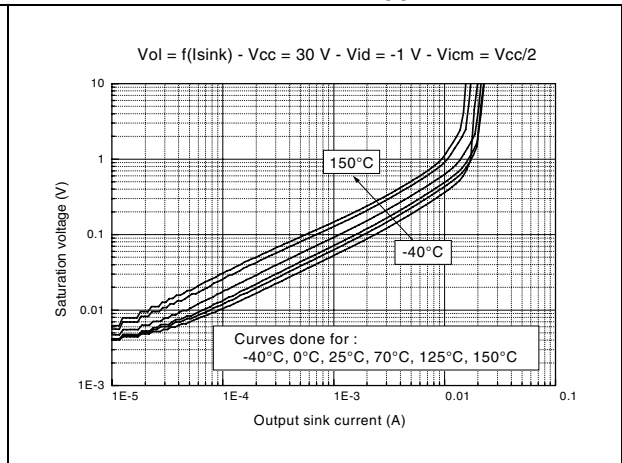

Figure 7. Response time for various input overdrives - positive transition

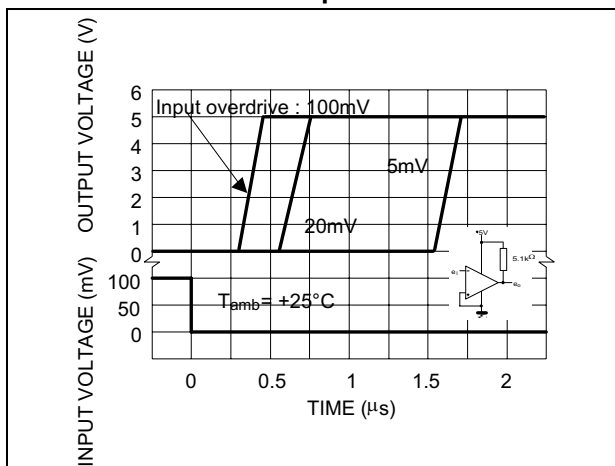
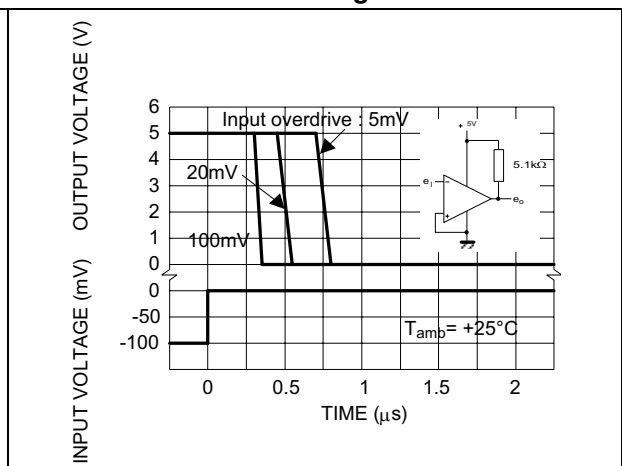

Figure 8. Response time for various input overdrives - negative transition



## 4 Package information

In order to meet environmental requirements, ST offers these devices in different grades of ECOPACK<sup>®</sup> packages, depending on their level of environmental compliance. ECOPACK<sup>®</sup> specifications, grade definitions and product status are available at: [www.st.com](http://www.st.com). ECOPACK<sup>®</sup> is an ST trademark.

Figure 9. SO-14 package mechanical drawing

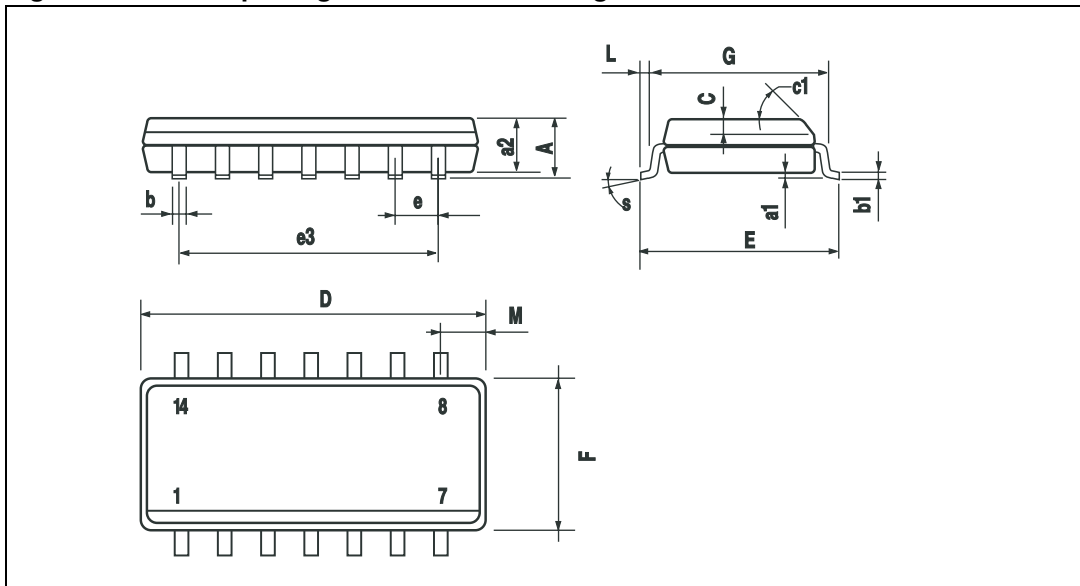

Table 4. SO-14 package mechanical data

Ref.	Dimensions					
	Millimeters			Inches		
	Min.	Typ.	Max.	Min.	Typ.	Max.
A			1.75			0.068
a1	0.1		0.2	0.003		0.007
a2			1.65			0.064
b	0.35		0.46	0.013		0.018
b1	0.19		0.25	0.007		0.010
C		0.5			0.019	
c1	45° (typ.)					
D	8.55		8.75	0.336		0.344
E	5.8		6.2	0.228		0.244
e		1.27			0.050	
e3		7.62			0.300	
F	3.8		4.0	0.149		0.157
G	4.6		5.3	0.181		0.208
L	0.5		1.27	0.019		0.050
M			0.68			0.026
S	8° (max.)					

## 5 Ordering information

**Table 5. Order codes**

Order code	Temperature range	Package	Packing	Marking
JLM2901H- I6D1	-40°C, +150°C	Wafer		
LM2901HD LM2901HDT		SO-14	Tube or Tape & reel	2901H
LM2901HYDT <sup>(1)</sup>		SO-14 (Automotive grade)	Tape & reel	2901HY

1. Qualified and characterized according to AEC Q100 and Q003 or equivalent, advanced screening according to AEC Q001 & Q 002 or equivalent.



## 6 Revision history

**Table 6. Document revision history**

Date	Revision	Changes
25-Sep-2003	1	Initial release.
07-Jul-2005	2	PPAP references inserted in the datasheet, see Order codes table.
08-Nov-2005	3	Table data reformatted for easier use in <i>Electrical characteristics</i> . Curves added in <i>Electrical characteristics</i> section.
08-Apr-2008	4	Added ESD parameters in AMR table. Added operating conditions table. Added footnotes for automotive grade order codes in order codes table. Reformatted document.
12-Mar-2012	5	Changed value of $T_J$ in <i>Table 1: Absolute maximum ratings (AMR)</i> . Removed LM2901HYD order code from <i>Table 5</i> .

**Please Read Carefully:**

Information in this document is provided solely in connection with ST products. STMicroelectronics NV and its subsidiaries ("ST") reserve the right to make changes, corrections, modifications or improvements, to this document, and the products and services described herein at any time, without notice.

All ST products are sold pursuant to ST's terms and conditions of sale.

Purchasers are solely responsible for the choice, selection and use of the ST products and services described herein, and ST assumes no liability whatsoever relating to the choice, selection or use of the ST products and services described herein.

No license, express or implied, by estoppel or otherwise, to any intellectual property rights is granted under this document. If any part of this document refers to any third party products or services it shall not be deemed a license grant by ST for the use of such third party products or services, or any intellectual property contained therein or considered as a warranty covering the use in any manner whatsoever of such third party products or services or any intellectual property contained therein.

**UNLESS OTHERWISE SET FORTH IN ST'S TERMS AND CONDITIONS OF SALE ST DISCLAIMS ANY EXPRESS OR IMPLIED WARRANTY WITH RESPECT TO THE USE AND/OR SALE OF ST PRODUCTS INCLUDING WITHOUT LIMITATION IMPLIED WARRANTIES OF MERCHANTABILITY, FITNESS FOR A PARTICULAR PURPOSE (AND THEIR EQUIVALENTS UNDER THE LAWS OF ANY JURISDICTION), OR INFRINGEMENT OF ANY PATENT, COPYRIGHT OR OTHER INTELLECTUAL PROPERTY RIGHT.**

**UNLESS EXPRESSLY APPROVED IN WRITING BY TWO AUTHORIZED ST REPRESENTATIVES, ST PRODUCTS ARE NOT RECOMMENDED, AUTHORIZED OR WARRANTED FOR USE IN MILITARY, AIR CRAFT, SPACE, LIFE SAVING, OR LIFE SUSTAINING APPLICATIONS, NOR IN PRODUCTS OR SYSTEMS WHERE FAILURE OR MALFUNCTION MAY RESULT IN PERSONAL INJURY, DEATH, OR SEVERE PROPERTY OR ENVIRONMENTAL DAMAGE. ST PRODUCTS WHICH ARE NOT SPECIFIED AS "AUTOMOTIVE GRADE" MAY ONLY BE USED IN AUTOMOTIVE APPLICATIONS AT USER'S OWN RISK.**

Resale of ST products with provisions different from the statements and/or technical features set forth in this document shall immediately void any warranty granted by ST for the ST product or service described herein and shall not create or extend in any manner whatsoever, any liability of ST.

ST and the ST logo are trademarks or registered trademarks of ST in various countries.

Information in this document supersedes and replaces all information previously supplied.

The ST logo is a registered trademark of STMicroelectronics. All other names are the property of their respective owners.

© 2012 STMicroelectronics - All rights reserved

STMicroelectronics group of companies

Australia - Belgium - Brazil - Canada - China - Czech Republic - Finland - France - Germany - Hong Kong - India - Israel - Italy - Japan - Malaysia - Malta - Morocco - Philippines - Singapore - Spain - Sweden - Switzerland - United Kingdom - United States of America

[www.st.com](http://www.st.com)